

# 2021-23 ANNUAL REPORT

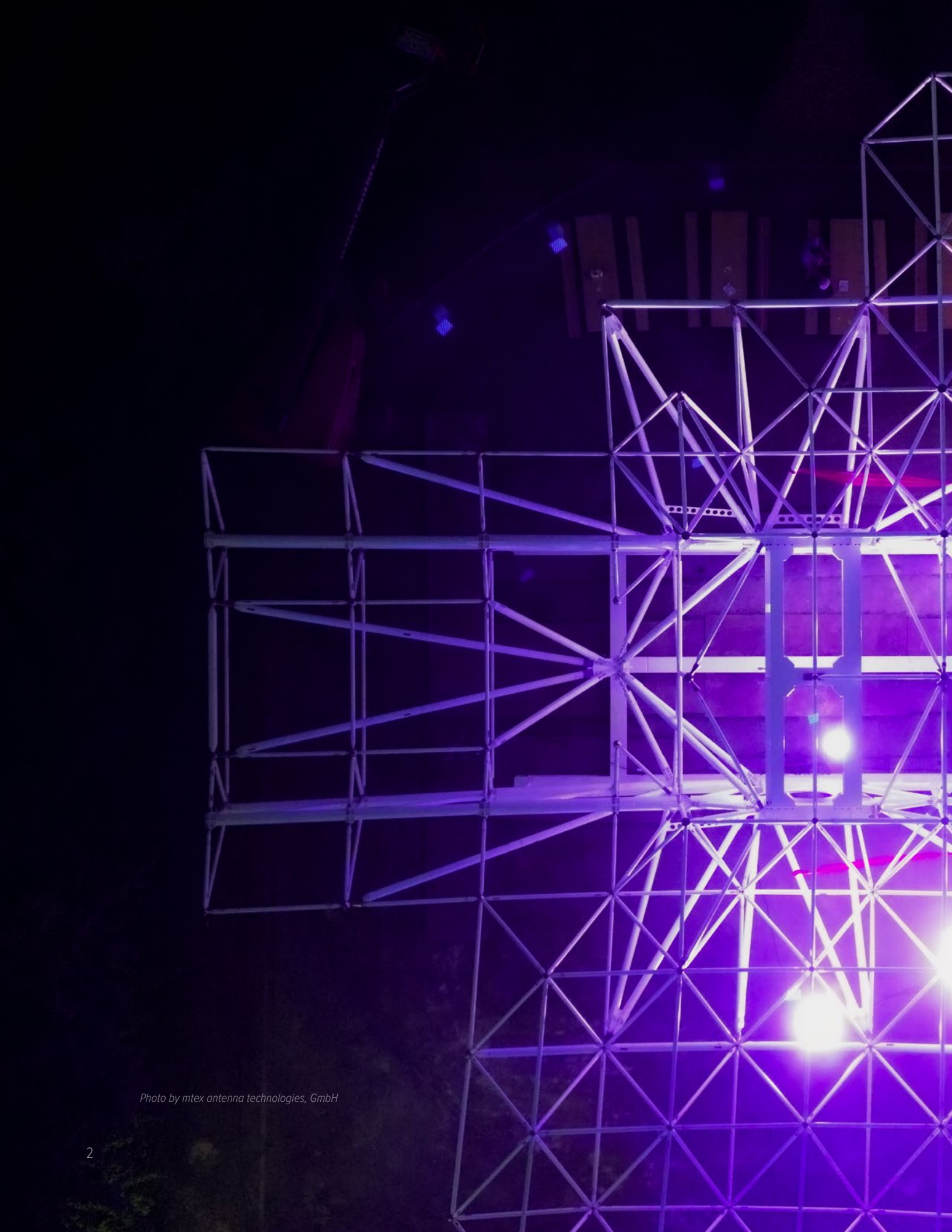

NATIONAL RADIO  
ASTRONOMY OBSERVATORY



*Photo by mtex antenna technologies, GmbH*

## Contents

DIRECTOR'S REPORT . . . . .	5
NRAO IN BRIEF . . . . .	6
SCIENCE HIGHLIGHTS . . . . .	8
NORTH AMERICAN ALMA OPERATIONS . . . . .	34
NEXT GENERATION VERY LARGE ARRAY . . . . .	44
NEW MEXICO OPERATIONS . . . . .	50
SCIENCE SUPPORT & RESEARCH . . . . .	66
DATA MANAGEMENT & SOFTWARE . . . . .	78
CENTRAL DEVELOPMENT LABORATORY . . . . .	84
EDUCATION & PUBLIC OUTREACH . . . . .	94
MANAGEMENT & ADMINISTRATION . . . . .	100
PERFORMANCE METRICS . . . . .	110
APPENDICES	
A. PUBLICATIONS . . . . .	118
B. EVENTS & MILESTONES . . . . .	276
C. ADVISORY COMMITTEES . . . . .	280
D. FINANCIAL SUMMARY . . . . .	286
E. ACRONYMS . . . . .	292

### NRAO FACTS & FIGURES 2021-2023

**499**  
EMPLOYEES



**144**  
MEDIA RELEASES



**2948**  
REFEREED  
SCIENCE PUBLICATIONS

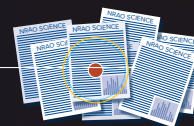

FRONT COVER: An ALMA antenna at sunset. Photo by Pablo Carrillo  
LEFT: ngVLA antenna structure begins assembly in Leipzig, Germany



*Photo by Pablo Carrillo, ALMA*

## DIRECTOR'S REPORT



In the past three years, we have emerged from the global covid-19 pandemic. Our Observatory successfully adapted and maintained safe science operations at the Karl G. Jansky Very Large Array (VLA), the Very Long Baseline Array (VLBA), and the Green Bank Observatory (GBO). The Atacama Large Millimeter/submillimeter Array (ALMA) continues to enable groundbreaking science in the areas of planetary disks, astrochemistry, star formation, and black holes in centers of galaxies. The National Radio Astronomy Observatory (NRAO) continues to push the boundaries of astronomical discovery with advanced radio telescope facilities.

The NRAO has returned to in-person functionality, re-establishing science and engineering relationships, and is taking advantage of meeting face to face to collaborate at our facilities and conferences. We have adjusted to a new normal with online meetings and hybrid events, all while successfully carrying out the mission of the Observatory.

I want to express appreciation to everyone who worked to make our facilities as safe as possible through the pandemic surges. I am proud of our proactive response and our ability to emerge successfully from the COVID landscape. NRAO has always been, and will continue to be, a strong, world-class scientific organization that supports its staff and users. NRAO remains committed to fostering collaboration and engagement within the scientific community and beyond. Through workshops, national and international conferences, and educational outreach programs, we strive to inspire the next generation of astronomers and engineers, and share the incredible science to the world's population.

The past three years have seen the development and planning of ALMA's Wideband Sensitivity Upgrade (WSU), the unveiling of the prototype next generation Very Large Array (ngVLA) antenna structure with our European partners, and the continuation of the VLA Sky Survey (VLASS) and its exploration of galaxies and transients.

The NRAO also made excellent progress in 2021-2023 on key strategic initiatives that are improving the Observatory's scientific capabilities and the community's ease-of-use, such as the Science Ready Data Products initiative that will enable the distribution of data products to a wider community of scientific users. On the technology side, the Central Development Lab is leading research and development efforts that build the instrumentation with which we study the Universe, enhancing our telescopes' sensitivity and resolution, and empowering astronomers to study cosmic phenomena with unparalleled precision. New directions such as radar capabilities and advanced spectrum monitoring are developing rapidly.

Our people are, of course, our greatest asset. We support the growth of a diverse and inclusive astronomical community via our Jansky Fellowships, Reber Fellows, student programs, and much more. With cross-Observatory support, these programs are contributing to the recruitment, retention, and success of talent across our field.

The NRAO staff are operating, maintaining, and continuously improving our world-leading radio telescopes, with the strong support of the National Science Foundation and Associated Universities, Inc. This Annual Report documents three pivotal years of NRAO that protected its people and facilities while also supporting the needs and interests of our global scientific community.

**Brief Bio:** Anthony (Tony) J. Beasley was appointed as NRAO Director by the AUI Board of Trustees effective 21 May 2012. After receiving his Bachelor's in Physics in 1986 and his Doctorate in Astrophysics in 1991 from the University of Sydney, Beasley joined NRAO as a Postdoctoral Fellow in 1991. He was appointed as a Deputy Assistant Director in 1997, and served as Assistant Director from 1998 to 2000. In 2000, he left NRAO to become Project Manager for the Combined Array for Research in Millimeter-wave Astronomy. In 2004, he returned to NRAO as an Assistant Director and Project Manager for the Atacama Large Millimeter/submillimeter Array in Chile. Prior to his appointment as NRAO Director, Beasley served as the Chief Operating Officer and Project Manager of the NSF-funded National Ecological Observatory Network (NEON), a continental-scale ecological observatory designed to detect ecological change and enable forecasting of its impacts.

## NRAO FACILITIES IN BRIEF



Created in 1956 by the NSF and AUI, the NRAO designs, builds, and operates world class astronomical telescopes, instrumentation, and research facilities at radio wavelengths. From 2021-2023, the NRAO operated a complementary suite of three world-class telescopes, each the world leader in its frequency domain: the international **Atacama Large Millimeter/submillimeter Array (ALMA)**, the **Karl G. Jansky Very Large Array (VLA)**, and the **Very Long Baseline Array (VLBA)**.

**ALMA** is the largest ground-based global astronomy endeavor in history. Composed of 66 high-precision antennas on an excellent 5000+ meter elevation site in northern Chile, ALMA is delivering orders of magnitude improvements in millimeter-wave sensitivity, frequency coverage, resolution, imaging, and spectral capabilities. ALMA's capabilities span wavelengths from 9.6 to 0.3 mm (31–950 GHz), a key part of the electromagnetic spectrum for observing the first stars and galaxies, directly imaging planet formation, and studying supermassive black holes. The community's strong interest in



ALMA has been repeatedly demonstrated by the substantial oversubscription of each Call for Proposals and the available observing time.

The **Karl G. Jansky VLA** in New Mexico has scientific capabilities at the adjacent centimeter-wavelength range that are complementary to ALMA. The current VLA capabilities exceed the original VLA design by one to four orders of magnitude. These new capabilities were delivered on schedule and on budget via the Expanded Very Large Array project, and the array is meeting all of the project's technical specifications and scientific objectives. The upgraded VLA transitioned to full science operations in January 2013 as the world's most capable and versatile centimeter-wavelength imaging array and is yielding dramatic new science results that range from Galactic protostellar clouds to the molecular gas in early galaxies.

The **VLBA** is the premier dedicated Very Long Baseline Interferometer (VLBI) array. Astrometry with the VLBA has



reached the precision of a few micro-arcseconds, supporting distance and proper motion measurements of astronomical objects in the solar neighborhood, across the Milky Way, within the Local Group, and moving with the Hubble flow. When used in conjunction with the phased VLA and GBT, the resultant High Sensitivity Array (HSA) vastly enhances the sensitivity of VLBI observations and increases the range of novel scientific research.

The **Central Development Laboratory (CDL)** conducts the technological research and development that improves operational NRAO telescopes and helps realize next generation facilities. CDL oversees a science-driven research and development program that supports the community's highest priority goals.

**NRAO Headquarters** in Charlottesville, Virginia is home to the North American ALMA Science Center (NAASC), Business & Administration, Human Resources, Education & Public Outreach, Program Management, and the Director's Office.

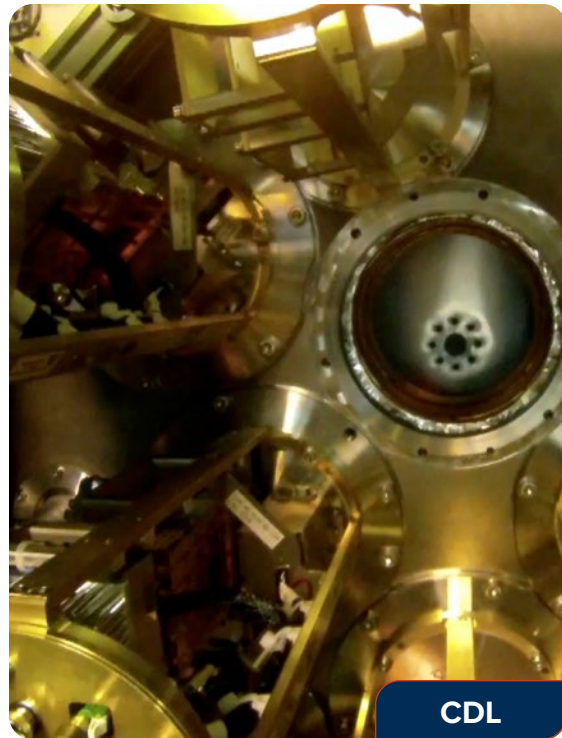

NRAO telescopes, operated individually and synergistically throughout 2021-2023 with optical, infrared, and X-ray telescopes to open new frontiers across a broad range of modern astrophysics: proto-planetary disks and extrasolar planet formation; astrochemistry; the early phases of star formation; fundamental physics; molecular gas in early galaxies; the environments of supermassive black holes; cosmology; and much more.

In addition to research, the NRAO informs society about science via its education and public outreach programs. A program of compelling science, technology, engineering, art, and mathematics (STEAM) education programs are introducing students every year to the excitement and opportunities of careers in science, computing, and engineering.

After more than six decades of continual improvement under AUI management, the NRAO comprises the nation's core competency in radio astronomy, an invaluable resource for the astronomical research community in the United States and around the world.

## SCIENCE HIGHLIGHTS



*Galaxy NGC 3627 imaged by the PHANGs Project with ALMA. Credit: ALMA (ESO/NAOJ/NRAO)/ESA/NASA/PHANGS, Sophia Dagnello (NRAO)*



Distant quasars are unique tracers to study the formation of the earliest supermassive black holes (SMBHs) and the history of cosmic reionization. Despite extensive efforts, only two quasars have been found at  $z \geq 7.5$ , due to a combination of their low spatial density and the high contamination rate in quasar selection. Wang et al. report the discovery of a luminous quasar at  $z = 7.642$ , J0313-1806, the most distant quasar yet known. This quasar has a bolometric luminosity of  $3.6 \times 10^{13} L_{\odot}$ . Deep spectroscopic observations reveal a SMBH with a mass of  $(1.6 \pm 0.4) \times 10^9 M_{\odot}$  in this quasar. The existence of such a massive SMBH just  $\sim 670$  million years after the Big Bang challenges significantly theoretical models of SMBH growth. In addition, the quasar spectrum exhibits strong broad absorption line (BAL) features in C IV and Si IV, with a maximum velocity close to 20% of the speed of light. The relativistic BAL features, combined with a strongly blueshifted C IV emission line, indicate that there is a strong active galactic nucleus (AGN)-driven outflow in this system. **Atacama Large Millimeter/submillimeter Array (ALMA)** observations detect the dust continuum and [C II] emission from the quasar host galaxy, yielding an accurate redshift of  $7.6423 \pm 0.0013$  and suggesting that the quasar is hosted by an intensely star-forming galaxy, with a star formation rate of  $\sim 200 M_{\odot} \text{ yr}^{-1}$  and a dust mass of  $\sim 7 \times 10^7 M_{\odot}$ . These observations present the most extreme example of coeval formation of a black hole and galaxy in the very early Universe. Follow-up observations of this reionization-era BAL quasar will provide a powerful probe of the effects of AGN feedback on the growth of the earliest massive galaxies (Wang et al. 2021, ApJL, 907, L1).

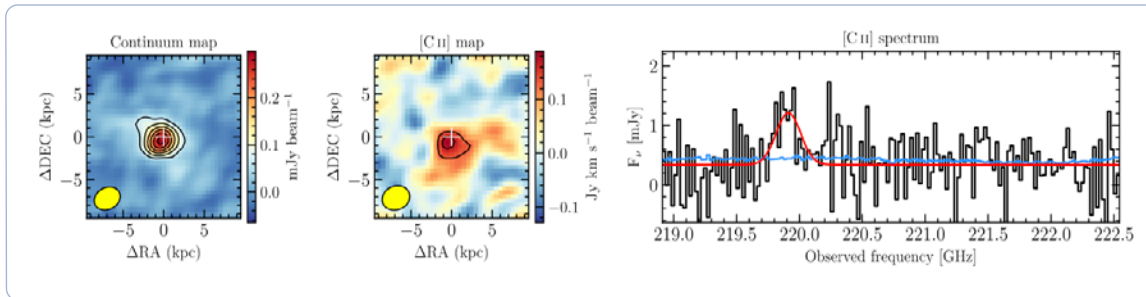

ALMA observations of the dust continuum and [C II] line. [Left] The dust continuum map with contour levels of [3, 5, 7, 9, 11, 13]  $\times 0.02$  mJy. [Middle] The integrated [C II] emission with contour levels of [3, 4]  $\times 0.04$  Jy km s<sup>-1</sup>. The sizes of the continuum cutout and the [C II] cutout are 4"  $\times$  4". The white crosses in the left and middle panels highlight the quasar position derived from VISTA Hemisphere Survey infrared images. [Right] The [C II] spectrum (black) and noise vector (blue) extracted from the data cube with an aperture diameter of 15 centered at the peak position of the continuum map. The spectral fitting (red line) gives FWHM =  $312 \pm 94$  km s<sup>-1</sup> and  $z[\text{CII}] = 7.6423 \pm 0.0013$  (Wang et al. 2021, ApJL, 907, L1).

Powerful radio jets from supermassive black holes (SMBHs) have a profound influence on their local environments, regulating star formation in the host galaxy and polluting the intergalactic medium with atoms and magnetic fields. They may also facilitate the formation of SMBH by removing angular momentum from the accretion disk. However, finding radio Active Galactic Nuclei in the early Universe has proven difficult. Radio sources at the highest redshifts provide unique information on the first massive galaxies and black holes, the densest primordial environments, and the epoch of reionization. The number of astronomical objects identified at  $z > 6$  has increased dramatically over the last few years, but previously only three radio-loud sources have been reported at  $z > 6$ , the most distant being a quasar at  $z = 6.18$ . These two contributions—from the **Jansky Very Large Array** (VLA: Bañados et al. 2021, ApJ, 909, 80) and the **Very Long Baseline Array** (VLBA: Momjian et al. 2021, AJ, 161, 207)—report the discovery and characterization of the most distant radio-loud Active Galactic Nucleus to date, at  $z = 6.82$ , or just  $\sim 800$  Myr after the Big Bang. This source has a black hole mass of  $\sim 3 \times 10^8 M_{\odot}$  and is one of the fastest accreting quasars. The VLBA imaging implies a marginally resolved source, with a size  $\leq 10$  milli-arcseconds, or  $\sim 50$  parsecs. The small size, but steep radio spectrum at high frequency, implies a very young radio jet, with an estimated age of only  $\sim 2000$  years.

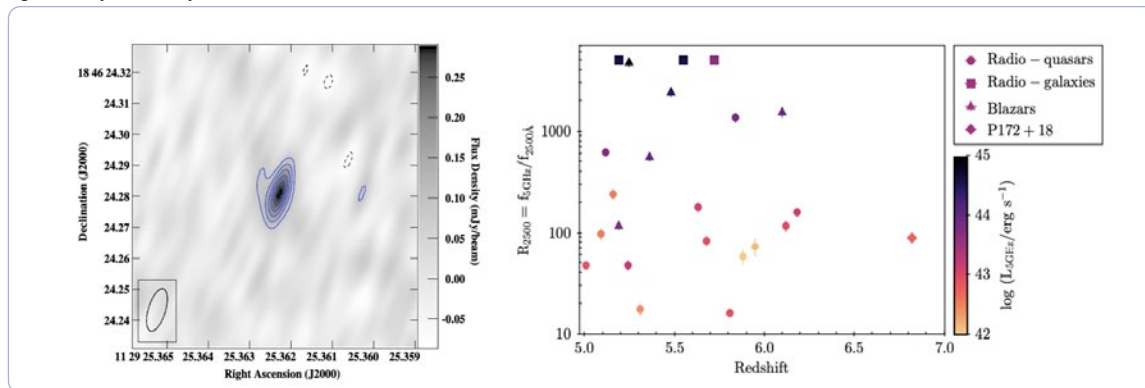

[Left] VLBA 1.4 GHz image of the  $z = 6.8$  radio loud quasar. [Right] A compilation of all the  $z > 5$  radio loud AGN known (Bañados et al. 2021; Momjian et al. 2021).

Blazars and Radio Structures

Multi-frequency observations were obtained with the **Jansky Very Large Array (VLA)** and the **Very Long Baseline Array (VLBA)** of the blazar PSO J030947.49+271757.31 (hereafter PSO J0309+27) detected at  $z = 6.10 \pm 0.03$ . The milli-arcsecond angular resolution of the VLBA observations at 1.5, 5, and 8.4 GHz unveil a bright one-sided jet extended for  $\sim 500$  parsecs in projection. This high- $z$  radio-loud Active Galactic Nucleus is resolved into multiple compact sub-components, embedded in a more diffuse and faint radio emission, which enshrouds them in a continuous jet structure. The authors derive limits on some physical parameters directly from the observable quantities, such as viewing angle, Lorentz and Doppler factors. If PSO J0309+27 is a genuine blazar, as suggested by its X-ray properties, then its bulk Lorentz factor must be relatively low (less than 5). Such values would favor a scenario currently proposed to reconcile the paucity of high- $z$  blazars with respect to current predictions. Nevertheless, the authors cannot exclude that PSO J0309+27 is seen under a larger viewing angle, which would imply that the X-ray emission must be enhanced, e.g., by inverse Compton with the Cosmic Microwave Background. More stringent constraints on the bulk Lorentz factor in PSO J0309+27 and the other high- $z$  blazars are necessary to test whether their properties are intrinsically different with respect to the low- $z$  blazar population (Spingola et al. 2020, A&A, 643, L12).

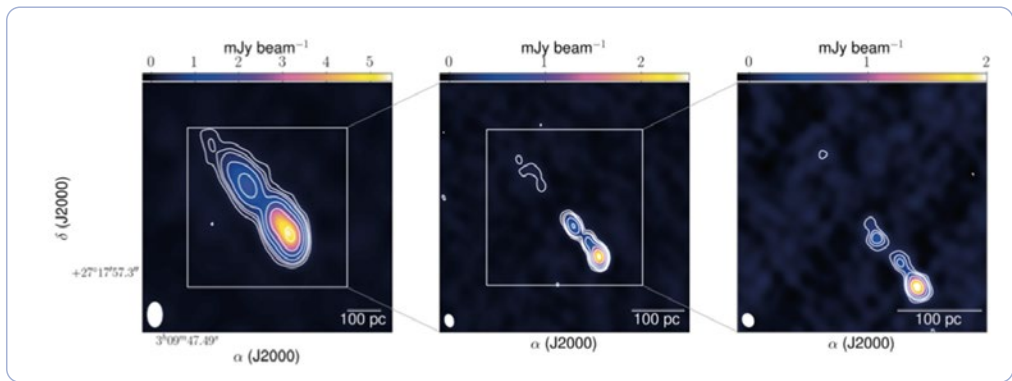

[Left to Right] VLBA images of the  $z=6.1$  blazar at 1.5 GHz, 5 GHz, and 8.4 GHz, down to 2 milli-arcsecond resolution (Spingola et al. 202, A&A, 643, L12).

New deep, high-resolution, 1.5 GHz observations of the prototypical nearby Perseus galaxy cluster were obtained from the **Karl G. Jansky Very Large Array**. They isolate for the first time the complete tail of radio emission of the bent-jet radio galaxy NGC 1272, which had been previously mistaken to be part of the radio mini-halo. The possibility that diffuse radio galaxy emission contributes to mini-halo emission may be a general phenomenon in relaxed cool-core clusters, and should be explored. The collimated jets of NGC 1272 initially bend to the west, and then transition eastward into faint, 60 kpc extensions with eddy-like structures and filaments. The authors suggest interpretations for these structures that involve bulk motions of intracluster gas, the galaxy's orbit in the cluster including projection effects, and the passage of the galaxy through a sloshing cold front. Instabilities and turbulence created at the surface of this cold front and in the turbulent wake of the infalling host galaxy most likely play a role in the formation of the observed structures. The authors also discover a series of faint rings, south-east of NGC 1272, a type of structure that has never been seen in galaxy clusters (Gendoon-Marsolais et al. 2021, ApJ, 911, L56).

Sloan Digital Sky Survey mosaic with VLA images of radio jets in the Perseus cluster, showing the strong interaction of the jets with the cluster gas on 100 kpc scales (Gendoon-Marsolais et al. 2021, ApJ, 911, L56).



## Our Solar System and Nearby Stars

Spatially resolved (0.1-1.0 arcsec) radio maps of Neptune were acquired with the **Jansky Very Large Array** and the **Atacama Large Millimeter/submillimeter Array** between 2015 and 2017. Combined, these observations probe from just below the main methane cloud deck at  $\sim 1$  bar down to the  $\text{NH}_4\text{SH}$  cloud at  $\sim 50$  bar. Prominent latitudinal variations in the brightness temperature are seen across the disk. Depending on wavelength, the south polar region is 5 K to 40 K brighter than the mid-latitudes and northern equatorial region. The authors use radiative transfer modeling coupled to Markov Chain Monte Carlo methods to retrieve  $\text{H}_2\text{S}$ ,  $\text{NH}_3$ , and  $\text{CH}_4$  abundance profiles across the disk, though only strong constraints can be made for  $\text{H}_2\text{S}$ .

Below all cloud formation, the data are well fit by  $53.8^{+18.9}_{-13.4} \times$  and  $3.9^{+2.1}_{-3.1} \times$  protosolar enrichment in the  $\text{H}_2\text{S}$  and  $\text{NH}_3$  abundances, respectively, assuming a dry adiabat. Models in which the radio-cold mid-latitudes and northern equatorial region are supersaturated in  $\text{H}_2\text{S}$  are statistically favored over models following strict thermochemical equilibrium.  $\text{H}_2\text{S}$  is more abundant at the equatorial region than at the poles, indicative of strong, persistent global circulation. These results imply that Neptune's sulfur-to-nitrogen ratio exceeds unity, as  $\text{H}_2\text{S}$  is more abundant than  $\text{NH}_3$  in every retrieval. The absence of  $\text{NH}_3$  above 50 bar can be explained either by partial dissolution of  $\text{NH}_3$  in an ionic ocean at GPa pressures or by a planet formation scenario in which hydrated clathrates preferentially delivered sulfur rather than nitrogen onto planetesimals, or a combination of these hypotheses (Tollefson et al. 2021, The Planetary Science Journal, 2, Issue 3, L105).

*Examples of VLA and ALMA images of Neptune.*  
(Tollefson et al. 2021)

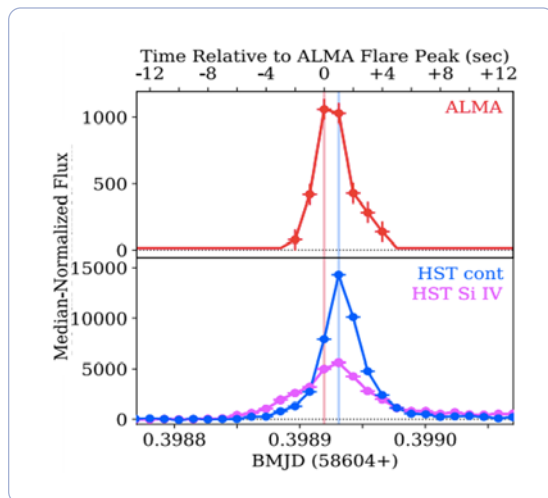
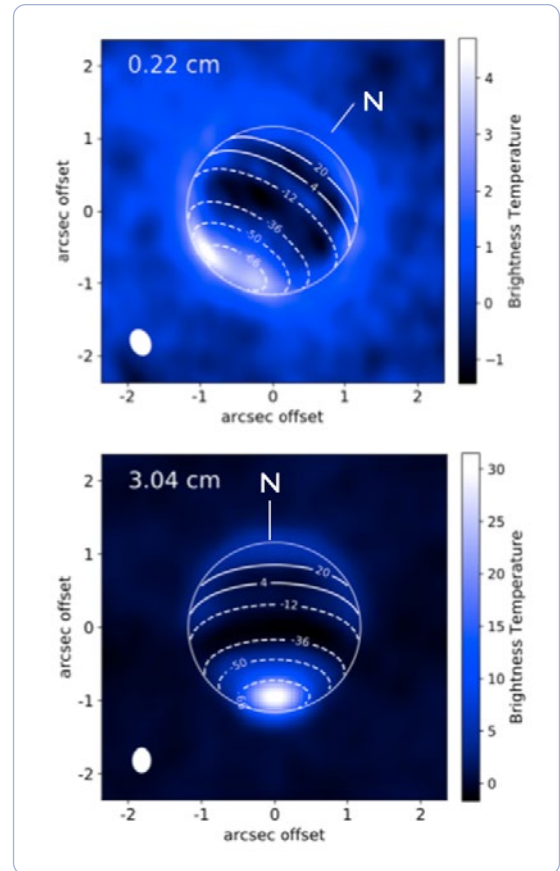

*VLA 1.3cm and HST UV light curves of the extreme flare from Proxima Centauri (MacGregor et al. 2021).*

M-dwarfs are the most common stars, and the most likely to host planets that could harbor life. The M-dwarf Proxima Centauri is at the center of the habitability discussion. It is the nearest exoplanetary system (1.3 parsecs) and has a likely Earth-mass planet with  $T \sim 230$  K at 0.05 AU. MacGregor et al. present here the discovery of an extreme flaring event from Proxima Centauri by the Australian Square Kilometre Array Pathfinder (ASKAP), **Atacama Large Millimeter/submillimeter Array (ALMA)**, Hubble Space Telescope (HST), Transiting Exoplanet Survey Satellite (TESS), and the du Pont Telescope that occurred on May 1, 2019. In the millimeter and far ultraviolet (FUV), this flare is the brightest ever detected, brightening by a factor of  $>1000$  and  $>14,000$  as seen by ALMA and HST, respectively. The millimeter and FUV continuum emission trace each other closely during the flare, suggesting that millimeter emission could serve as a proxy for FUV emission from stellar flares and become a powerful new tool to constrain the high-energy radiation environment of exoplanets. Surprisingly, optical emission associated with the event peaks at a much lower level with a time delay. The initial burst has an extremely short duration, lasting less than 10 seconds. Taken together with the growing sample of millimeter M dwarf flares, this event suggests that millimeter emission is actually common during stellar flares and often originates from short burst-like events. Extreme flares are driven by magnetic reconnection in the stellar atmosphere, and indicate a highly magnetically active star. The heightened magnetic activity of M-dwarfs could be detrimental to the life formation process (MacGregor et al. 2021, ApJL, 911, Issue 2, L25).

## Star Formation

De Pree et al. present new **Jansky Very Large Array (VLA)** images of the central region of the W49A star-forming region at 3.6 cm and at 7 mm at resolutions of 0.15 arcsec (1650 AU) and 0.04 arcsec (440 AU), respectively. The 3.6 cm data reveal new morphological detail in the ultracompact H II region population, as well as several previously unknown and unresolved sources. In particular, source A shows elongated, edge-brightened bipolar lobes, indicative of a collimated outflow, and source E is resolved into three spherical components.

The authors also present **VLA** observations of radio recombination lines at 3.6 cm and 7 mm, and IRAM Northern Extended Millimeter Array (NOEMA) observations at 1.2 mm. Three of the smallest ultracompact H II regions (sources A, B2, and G2) all show broad kinematic linewidths, with  $\Delta V_{\text{FWHM}} \sim 40 \text{ km s}^{-1}$ . A multi-line analysis indicates that broad linewidths remain after correcting for pressure broadening effects, suggesting the presence of supersonic flows. Substantial changes in linewidth over the 21 yr time baseline at both 3.6 cm and 7 mm are found for source G2. At 3.6 cm, the linewidth of G2 changed from  $31.7 \pm 1.8 \text{ km s}^{-1}$  to  $55.6 \pm 2.7 \text{ km s}^{-1}$ , an increase of  $+23.9 \pm 3.4 \text{ km s}^{-1}$ . The G2 source was previously reported to have shown a 3.6 cm continuum flux density decrease of 40% between 1994 and 2015. This source sits near the center of a very young bipolar outflow whose variability may have produced these changes (De Pree et al. 2020, AJ, 160, 234).

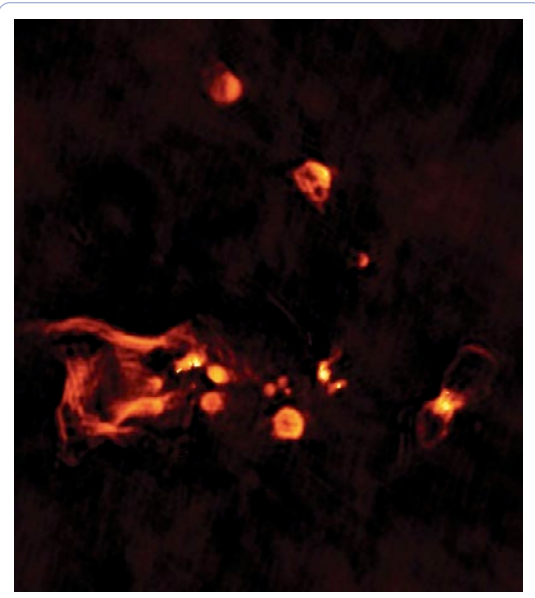

VLA 3.6cm image at 0.15 arcsec resolution of W49A (De Pree et al. 2020, AJ, 160, 234).

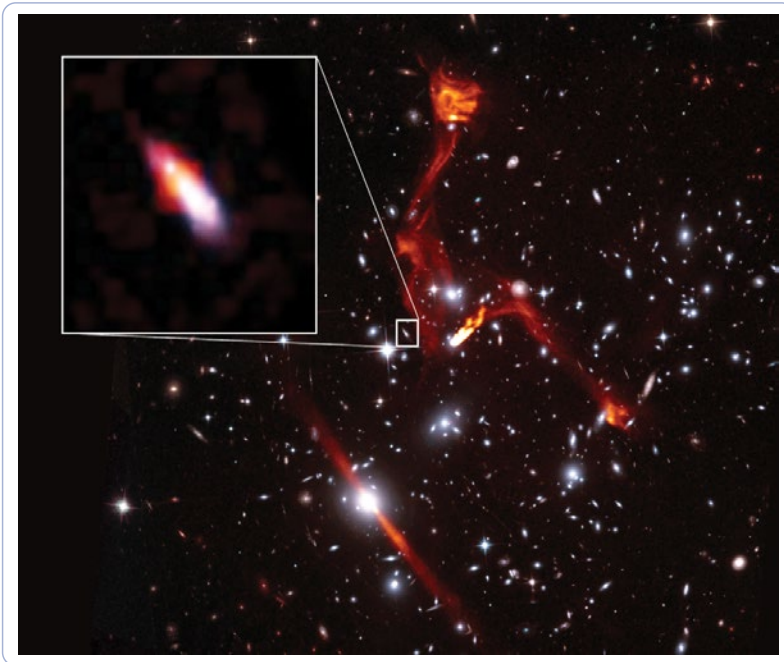

Composite Very Large Array (3 GHz) and Hubble Space Telescope image, of the Frontier field MACSJ0717.5+3745 at 0.6 arcsec resolution. The large diffuse structures are radio relics and jets in the lensing cluster. The faintest source (inset) corresponds to a de-magnified flux density of 0.9 micro-Jy and is a star-forming galaxy at  $z \sim 1$  (Heywood et al. 2021, ApJ, 910, 105; Jiménez-Andrade et al. 2021, ApJ, 910, 106).

The **Jansky Very Large Array** has performed ultra-deep (1 micro-Jy rms), high-resolution ( $< 0.6$  arcsec) imaging of the Hubble Space Telescope cluster-lensed Frontier fields. These observations reveal hundreds of distant star-forming galaxies, from which the authors derive star formation rates and source sizes, unbiased by dust obscuration.

The faintest reliably identified radio source corresponds to a galaxy at  $z \sim 1$ , with a star formation rate of only  $10 M_{\odot} \text{ yr}^{-1}$ , making it the faintest high-redshift star-forming galaxy detected to date in the radio continuum.

The observations of strongly-lensed fields provide important information for planning future deep fields with the Square Kilometre Array and the next generation Very Large Array (Heywood et al. 2021, ApJ, 910, 105; Jiménez-Andrade et al. 2021, ApJ, 910, 106).

## M87 in the Virgo Cluster

The Event Horizon Telescope (EHT), featuring the **Atacama Large Millimeter/submillimeter Array** (ALMA) as its anchor element, has presented their polarimetric imaging at 240 GHz around the supermassive black hole in M87 on event-horizon scales. This polarized synchrotron radiation probes the structure of magnetic fields and the plasma properties near the black hole. The field geometry appears as a spiral. The fractional polarization is low (<20%), indicating high Faraday rotation, from which the research team estimates  $n_e \sim 10^{4.7} \text{ cm}^{-3}$ ,  $B \sim 1\text{-}30 \text{ G}$ , and  $T_e \sim (1\text{-}12) \times 10^{10} \text{ K}$ , in the radiating plasma.

The collaboration shows that the net azimuthal linear polarization pattern may result from organized, poloidal magnetic fields in the emission region. In a quantitative comparison with a large library of simulated polarimetric images from general relativistic magnetohydrodynamic (GRMHD) simulations, the authors identify a subset of physical models that can explain critical features of the polarimetric EHT observations while producing a relativistic jet of sufficient power. The consistent GRMHD models are all of magnetically arrested accretion disks, where near-horizon magnetic fields are dynamically important. Models enable the team to infer a mass accretion rate onto the black hole in M87 of  $(3\text{-}20) \times 10^{-4} M_{\odot} \text{ yr}^{-1}$ . Strong fields may also be key to the physics of relativistic jet launch (EHT Collaboration 2021, ApJL, 910, L13).

*EHT 240 GHz images of total intensity, and fractional polarization and position angle in M87.*

*ALMA, VLBA, and EHT observations of Virgo Cluster galaxy M87.*

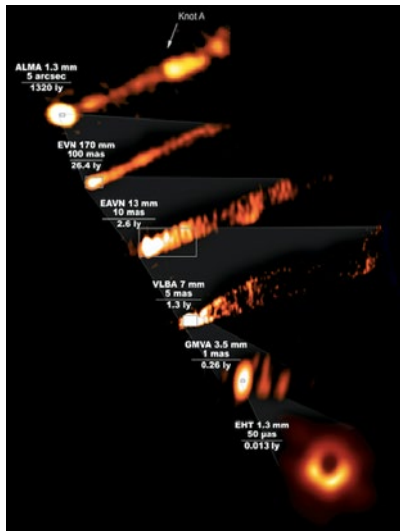

Compton emission in the same region producing the EHT mm-band emission, and further concluded that the  $\gamma$ -rays can only be produced in the inner jets (inward of HST-1) if there are strongly particle-dominated regions. Direct synchrotron emission from accelerated protons and secondaries cannot yet be excluded.

To better understand the black hole at the core of galaxy M87, the EHT Collaboration mounted a multi-wavelength observing campaign. Observations across the electromagnetic spectrum in radio, visible-light, ultraviolet, X-ray, and gamma-ray revealed the far-reaching impact of the supermassive black hole on its surroundings (EHT Collaboration 2021, ApJL, 910, L11).

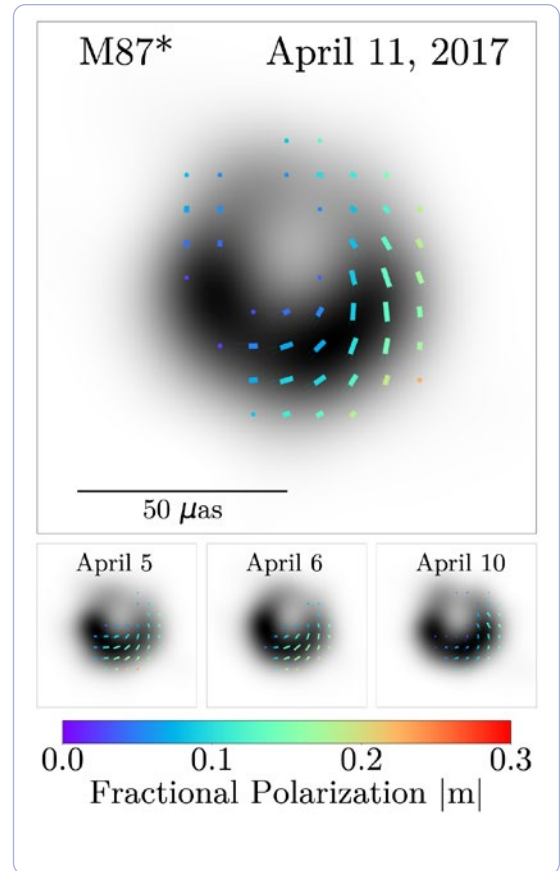

## Protoplanetary Disks and Protostars

Elias 2-27 is a 0.8 Myr old M-star, with a massive protoplanetary disk. The disk has a 14 AU wide gap at 69 AU radius, suggesting a 0.1M<sub>J</sub> forming planet. **Atacama Large Millimeter / submillimeter Array (ALMA)** imaging of the dust and CO(3-2) emission reveals spiral arms, and a rotating disk, providing the first dynamical mass estimate of a protoplanetary disk, with:  $M_{\text{star}} = 0.46 M_{\odot}$  and  $M_{\text{disk}} = 0.08 M_{\odot}$ . Departures from Keplerian rotation suggest instabilities which may lead to planet formation (Paneque-Carreño et al. 2021, ApJ, 914, 88).

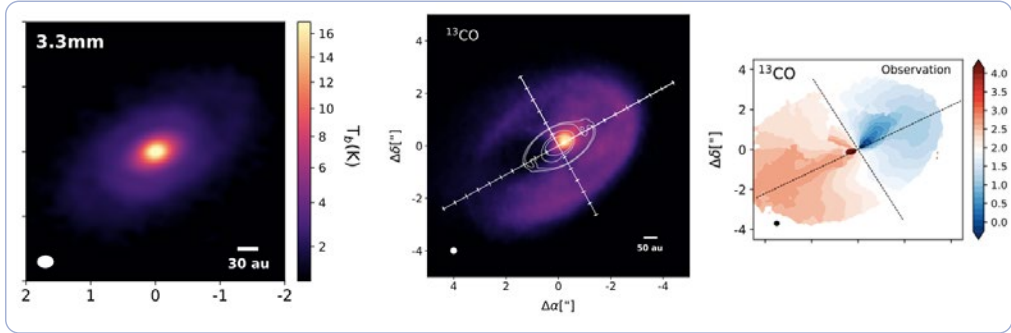

*ALMA imaging of the protoplanetary disk of Elias 2-27. [Left] 3.3mm dust emission. [Center & Right] <sup>13</sup>CO 3-2 total intensity and the velocity field (Paneque-Carreño et al. 2021, ApJ, 914, 88).*

Protostellar jets have a fundamental role at the earliest evolution of protostars of all masses. In the case of low-mass (< 8 M<sub>⊙</sub>) protostars, strong observational evidence exists that the launching and collimation is due to the X- and/or disk-wind mechanisms. In these models, it is the protostar/disk system that creates all the necessary conditions to launch and collimate the jets near the protostar via strong magnetic fields. The origin of jets from more massive protostars has been investigated much less, in part because of the difficulty of resolving the collimation zone in these more distant objects. Here, the authors present the highest angular resolution observations of a jet powered by a massive protostar, the Cep A HW2 radio jet. The radio emission was imaged at projected distances of only ~20 AU from the protostar, resolving the innermost 100 AU of a massive protostellar jet for the first time. The morphology of the radio jet emission in this massive object is very different than what is usually observed in jets from low-mass protostars. The authors found that the outflowing material in HW2 has two components: a wide-angle wind launched from the protostar/disk system, and a highly collimated jet starting at 20-30 AU from the protostar. Two possible scenarios are discussed: an extension of the classical disk-wind to a massive protostar, or external collimation of a wide-angle wind. These results have important consequences for understanding how stars of different masses are formed (Carrasco-Gonzales et al. 2021, ApJL, 914, L1).

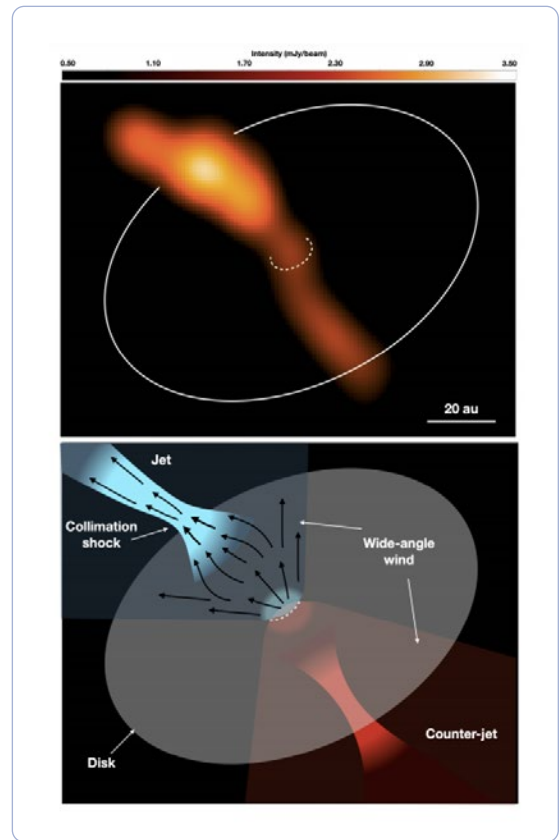

*(Above) VLA 40 GHz image of the jets in the massive protostar, Cep A HW2, at 40 milli-arcsec resolution. (Below) The model for the conical wind and the narrow jet (Carrasco-Gonzales et al. 2021, ApJL, 914, L1).*

## Galactic Plane First Results

Surveys of the Milky Way at various wavelengths have changed our view of star formation in our Galaxy considerably in recent years. In this paper, the authors give an overview of the Global View on Star formation in the Milky Way (GLOSTAR) survey, a new survey covering large parts (145 square degrees) of the northern Galactic plane using the **Jansky Very Large Array (VLA)** in the frequency range 4–8 GHz, and the Effelsberg 100-m telescope. This provides for the first time a radio survey covering all angular scales down to 1.5 arcsecond, similar to complementary near- and mid-infrared galactic plane surveys. The authors outline the main survey goals and provide a detailed description of the observations and the data reduction strategy.

In these observations, the radio continuum is covered in full polarization, as well as the 6.7 GHz methanol maser line, the 4.8 GHz formaldehyde line, and seven radio recombination lines. The observations were conducted in the most compact D configuration of the **VLA** and in the more extended B configuration. This yielded spatial resolutions of 18 arcsec and 1.5 arcsec for the two configurations, respectively. The authors also combined the D configuration images with the Effelsberg 100-m data to provide zero spacing information, and jointly imaged the D- and B-configuration data for optimal sensitivity of the intermediate spatial ranges (Brunthaler et al. 2021, A&A, 651, A85).

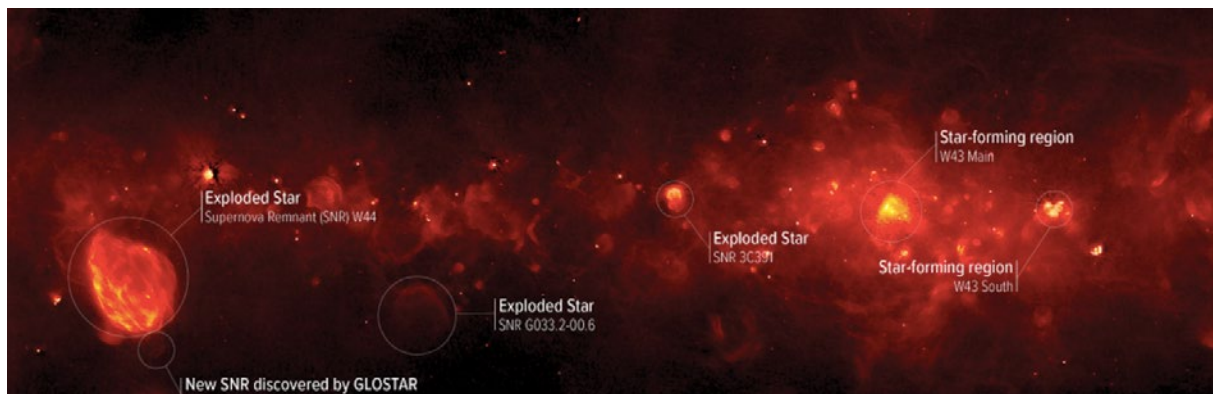

GLOSTAR 10 GHz image of the Galactic Plane (Brunthaler et al. 2021, A&A, 651, A85).

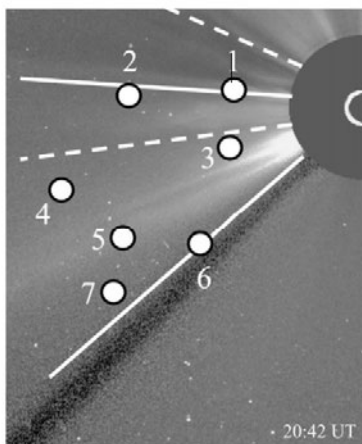

(Left) SOHO coronagraphic image of a CME, showing the location of background radio sources used for Faraday rotation measurements with the VLA. (Right) Time behavior of the rotation measures with passage of the CME in front of source 1 (Kooi et al. 2021, Solar Physics, 296, 11).

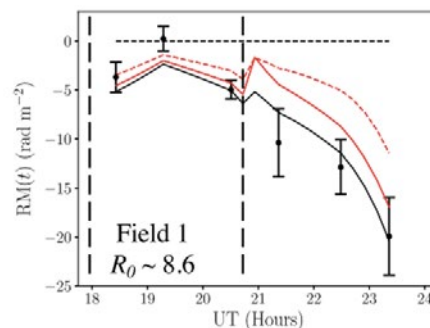

## Magnetic Field in a Coronal Mass Ejection

Coronal Mass Ejections (CMEs) are the most violent of space weather phenomena, traveling at  $\sim 1,000$  km/sec, with potential for major impact on the Earth. Polarization observations with the **Jansky Very Large Array**, coupled with real-time in situ density measurements by the Parker Solar Probe, have provided the most precise measurements of the magnetic field in a CME. Observations of the rotation measures toward background quasars through a CME yields a magnetic field strength of  $\sim 30$  mG at 10 solar radii. The fields help to “sculpt” the CME as it travels away from the Sun (Kooi et al. 2021, Solar Physics, 296, 11).

## Maintaining Future Star Formation

The authors investigate the effects of ram pressure on the molecular Interstellar Medium (ISM) in the disk of the Coma cluster galaxy NGC 4921, via high resolution CO observations. They present 6 arcsec resolution CO(1-0) observations of the full disk from the Combined Array for Research in Millimeter-wave Astronomy (CARMA), and 0.4 arcsec resolution **Atacama Large Millimeter/submillimeter Array** CO(2-1) observations of the leading quadrant, where ram pressure is strongest. They find evidence for compression of the dense ISM on the leading side, spatially correlated with intense star formation activity in this zone. They also detect molecular gas along kiloparsec-scale filaments of dust extending into the otherwise gas stripped zone of the galaxy, seen in Hubble Space Telescope images. The authors find the filaments are connected kinematically as well as spatially to the main gas ridge located downstream, consistent with cloud decoupling inhibited by magnetic binding, and inconsistent with a simulated filament formed via simple ablation. Furthermore, we find several clouds of molecular gas  $\sim 1-3$  kpc beyond the main ring of CO that have velocities which are blueshifted by up to 50 km/s with respect to the rotation curve of the galaxy. These are some of the only clouds detected here that do not have any visible dust extinction associated with them, suggesting that they are located behind the galaxy disk midplane and are falling back towards the galaxy. Simulations

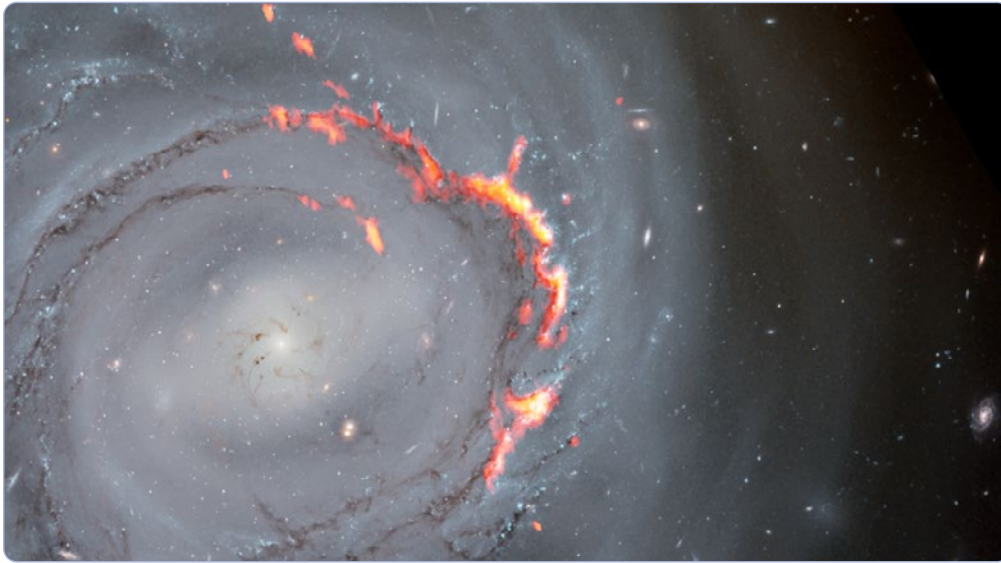

have long predicted that some gas removed from the galaxy disk will fall back during ram pressure stripping. This may be the first clear observational evidence of gas re-accretion in a ram pressure stripped galaxy (Cramer et al. 2021, ApJ, 921, 22).

*Composite ALMA CO(2-1) and Hubble Space Telescope image of the Virgo cluster spiral galaxy, NGC 4921 (Cramer et al. 2021, ApJ, 921, 22).*

## VLBA Images the First Extragalactic Neutrino Source

The **Very Long Baseline Array (VLBA)** demonstrated its unique ability to obtain the highest resolution images of parsec-scale relativistic jets with the discovery of a jet in the first known extragalactic neutrino source, the Blazar radio source TXS 0506+056.

High energy neutrinos were detected by IceCube from TXS 0506+056. **VLBA** images with  $\sim 0.5$  milli-arcsec resolution at 43 GHz detect complex jet structure and dynamics. Jet deceleration on scales  $\sim 100$  parsec is seen – likely due to proton loading by jet-star interactions in the inner galaxy (Ros et al. 2020, A&A, 633, L1).

*Nov 2017 and May 2018: Very Long Baseline Array 43 GHz images of the blazar TXS 0506+056 at  $\sim 0.5$  milli-arcsec resolution, showing complex jet structure and dynamics in this first extragalactic neutrino source (Ros et al. 2020, A&A, 633, L1).*

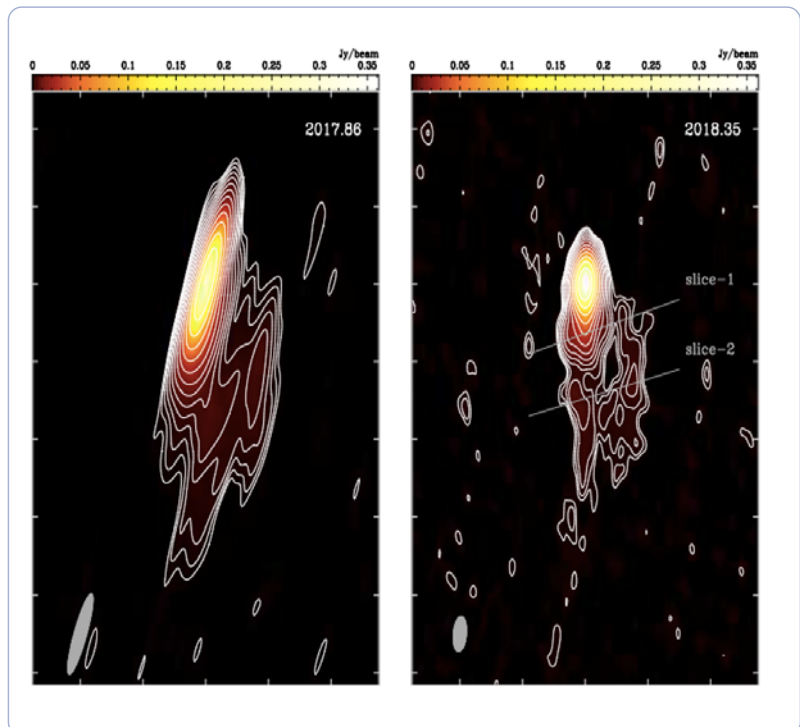



## ALMA and the First Galaxies

The Reionization Era Bright Emission Line Survey (REBELS) is a Cycle 7 **Atacama Large Millimeter/submillimeter Array (ALMA)** Large Program (LP) that is identifying and performing a first characterization of many of the most luminous star-forming galaxies known in the  $z > 6.5$  universe. REBELS is providing this probe by systematically scanning 40 of the brightest UV-selected galaxies identified over a seven square degree area for bright 158-micron [CII] and 88-micron [OIII] lines and dust-continuum emission. Selection of the 40 REBELS targets was done by combining photometric selections, each of which is subject to extensive vetting using three completely independent sets of photometry and template-fitting codes. Building on the observational strategy deployed in two pilot programs, the authors are increasing the number of massive interstellar medium (ISM) reservoirs known at  $z > 6.5$  by  $\sim 4\text{-}5\times$  to  $> 30$ . The authors motivate the observational strategy deployed in the REBELS program and present initial results. Based on the 60.6 hours of **ALMA** observations taken in the first year of the program (November 2019 to January 2020), 18 highly significant  $\sim 7\sigma$  [CII] lines have already been discovered, the bulk of which (13/18) also show  $\sim 3.3\sigma$  dust-continuum emission. These newly discovered lines more than triple the number of bright ISM-cooling lines known in the  $z > 6.5$  universe, such that the number of ALMA-derived redshifts at  $z > 6.5$  already rival Ly $\alpha$  redshift discoveries. An analysis of the completeness of our search results vs. star formation rate (SFR) suggests an  $\sim 79\%$  efficiency in scanning for [CII] when the SFR(UV+IR) is in excess of  $28 M_{\odot} \text{ yr}^{-1}$ . These new LP results further demonstrate ALMA's efficiency as a "redshift machine", particularly in the Epoch of Reionization (Bouwens et al. 2022, ApJ, 931, 160).

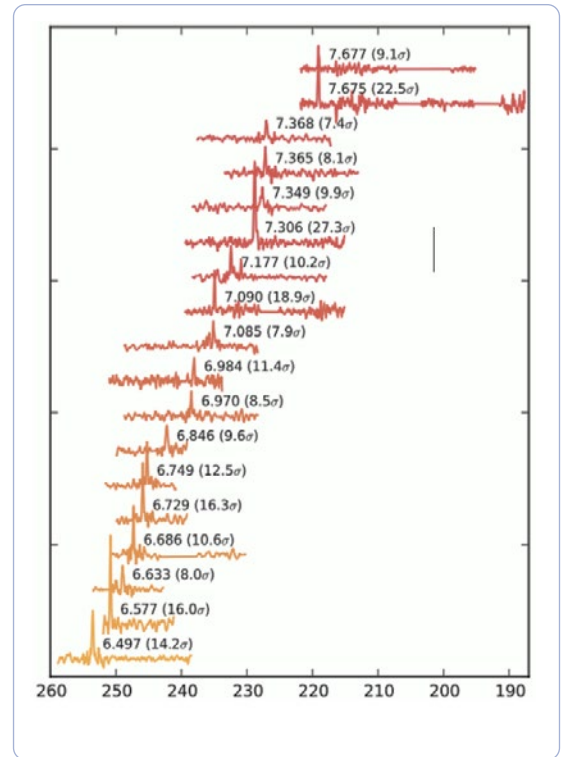

ALMA spectra of [CII] 158 micron emission from the REBELS sample at  $z = 6.5$  to 7.7 (Bouwens et al. 2022, ApJ, 931, 160).

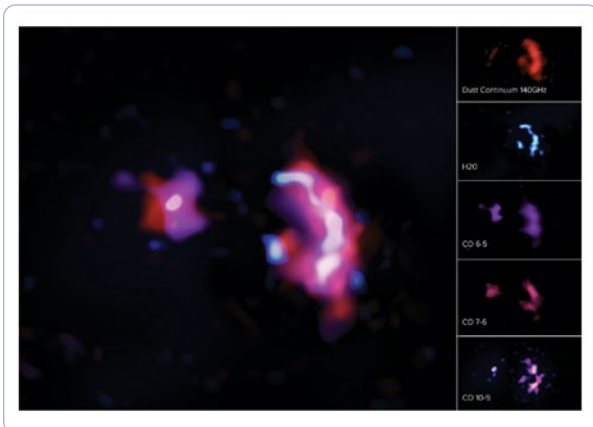

Composite showing the H<sub>2</sub>O, CO, and dust emission from a merging galaxy at  $z = 6.9$  (Jarugula et al. 2021, ApJ, 921, 97).

## Water in the Early Universe

SPT0311-58 is the most massive infrared luminous system discovered so far during the Epoch of Reionization (EoR). In this paper, the authors present a detailed analysis of the molecular interstellar medium at  $z = 6.9$ , through high resolution observations of the CO(6 – 5), CO(7 – 6), CO(10 – 9), [CII](2 – 1), and p-H<sub>2</sub>O(2<sub>p</sub>,1 – 2<sub>o</sub>,2) lines and dust continuum emission with the **Atacama Large Millimeter/submillimeter Array (ALMA)**. The system consists of a pair of intensely star-forming gravitationally lensed galaxies (labelled West and East). The intrinsic far-infrared luminosity is  $(16 \pm 4) \times 10^{12} L_{\odot}$  in West and  $(27 \pm 4) \times 10^{11} L_{\odot}$  in East. The authors model the dust, CO, and [CII] using non-local thermodynamic equilibrium radiative transfer models and estimate the intrinsic gas mass to be  $(5.4 \pm 3.4) \times 10^{11} M_{\odot}$  in West and  $(3.1 \pm 2.7) \times 10^{10} M_{\odot}$  in East. They find that the CO spectral line energy distribution in West and East are typical of high-redshift submillimeter galaxies (SMGs). The CO-to-H<sub>2</sub> conversion factor ( $\alpha_{\text{CO}}$ ) and the gas depletion time scales estimated from the model are consistent with the high-redshift SMGs in the literature within the uncertainties. They find no evidence of evolution of depletion time with redshift in SMGs at  $z > 3$ . This is the most detailed study of molecular gas content of a galaxy in the EoR to-date, with the most distant detection of H<sub>2</sub>O in a galaxy without any evidence for active galactic nuclei in the literature (Jarugula et al. 2021, ApJ, 921, 97).

## A New Type of Radio Transient

Comparison of images from the **Very Large Array Sky Survey** with older data from the Faint Images of the Radio Sky at Twenty-cm (FIRST) survey has revealed a new type of transient radio source, consistent with a merger-driven core collapse supernova. The source is associated with a soft gamma-ray burst detected in 2014 with the Monitor of All-sky X-ray Image (MAXI) instrument on the International Space Station. The new radio source is likely the result of a supernova driven by the collision between the neutron star or black hole companion of an evolved massive star. Such an event has been long theorized, but never before seen (Dong et al. 2021, *Science*, 373, 1125).

*VT 1210+4956 was not detected in FIRST in 1997 (A), but appears in the first epoch of the VLASS in 2017 (B). C shows the optical location in a dwarf galaxy at  $z = 0.035$ , and D shows the radio spectrum fit with a synchrotron self-absorption model (Dong et al. 2021, *Science*, 373, 1125).*

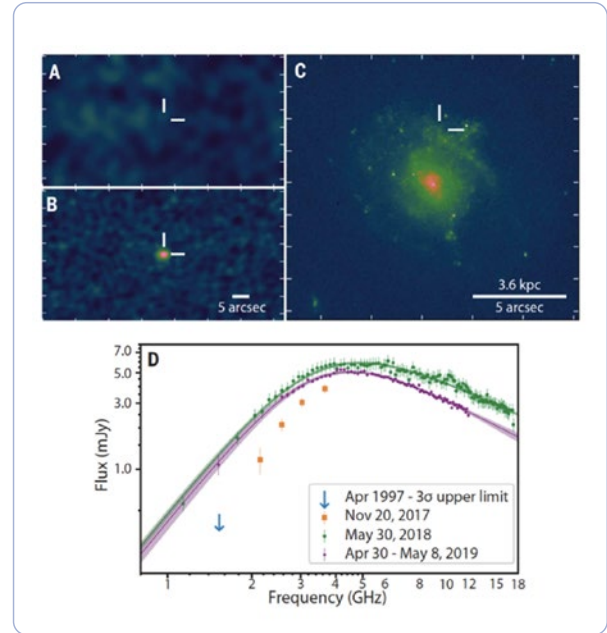

## GBT and VLBA Team Up To Image the Moon

The Green Bank Observatory, National Radio Astronomy Observatory, and Raytheon Intelligence & Space released a new high-resolution image of the Moon in September 2021, the highest-resolution ever taken from the ground, using new radar technology on the **Green Bank Telescope (GBT)**. The resolution of the new Tycho Crater image is close to five meters by five meters and contains  $\sim 1.4$  billion pixels. The image covers an area of 200 kilometers by 175 kilometers, ensuring that involved scientists and engineers captured the entire crater, which measures 86 kilometers in diameter. For these images, the GBT was outfitted in late 2020 with new technology developed by Raytheon Intelligence & Space and Green Bank Observatory, allowing it to transmit a radar signal into space. Using the GBT and antennas from the Very Long Baseline Array (VLBA), several additional tests have been conducted since that time, focusing on the surface of the Moon, including the Tycho Crater and NASA Apollo landing sites (Image courtesy of Raytheon/NRAO/AUI/NSF).

*This dramatic image of a 200 kilometer region with 5 meter resolution around the Tycho crater on the Moon was produced using the proto-type radar system at the GBO with VLBA antenna receiving stations (Image courtesy of Raytheon/NRAO/AUI/NSF).*

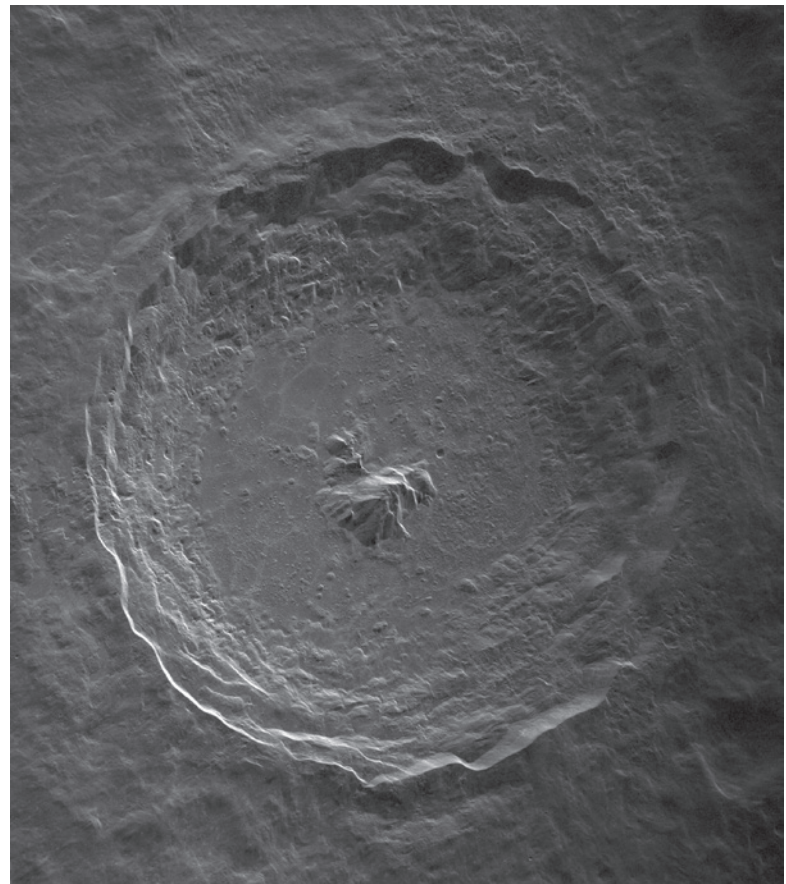

## How Galaxies Lose Their Gas

Brown et al. present the Virgo Environment Traced in CO (VERTICO) survey, a new effort to map  $^{12}\text{CO}(2-1)$ ,  $^{13}\text{CO}(2-1)$ , and  $\text{C}^{18}\text{O}(2-1)$  in 51 Virgo Cluster galaxies with the Atacama Compact Array, part of the **Atacama Large Millimeter/submillimeter Array (ALMA)**. The primary motivation of VERTICO is to understand the physical mechanisms that perturb molecular gas disks, and therefore star formation and galaxy evolution, in dense environments. This first paper contains an overview of VERTICO's design and sample selection,  $^{12}\text{CO}(2-1)$  observations, and data reduction procedures. The authors characterize global  $^{12}\text{CO}(2-1)$  fluxes and molecular gas masses for the 49 detected VERTICO galaxies, provide upper limits for the two non-detections, and produce resolved  $^{12}\text{CO}(2-1)$  data products (median resolution = 8 arcsec  $\approx$  640 pc). Azimuthally averaged  $^{12}\text{CO}(2-1)$  radial intensity profiles are presented along with derived molecular gas radii. The authors demonstrate the scientific power of VERTICO by comparing the molecular gas size–mass scaling relation for their galaxies with a control sample of field galaxies, highlighting the strong effect that radius definition has on this correlation. They discuss the drivers of the form and scatter in the size–mass relation and highlight areas for future work. VERTICO is an ideal resource for studying the fate of molecular gas in cluster galaxies and the physics of environment- driven processes that perturb the star formation cycle. Upon public release, the survey will provide a homogeneous legacy dataset for studying galaxy evolution in our closest cluster (Brown et al. 2021, ApJSS, 257, 21).

*Upper: CO(2-1) emission from galaxies in the Virgo cluster, plus the optical image. Lower: Molecular gas in the merging galaxy system NGC 4567 and 4568 (Brown et al. 2021, ApJSS, 257, 21).*

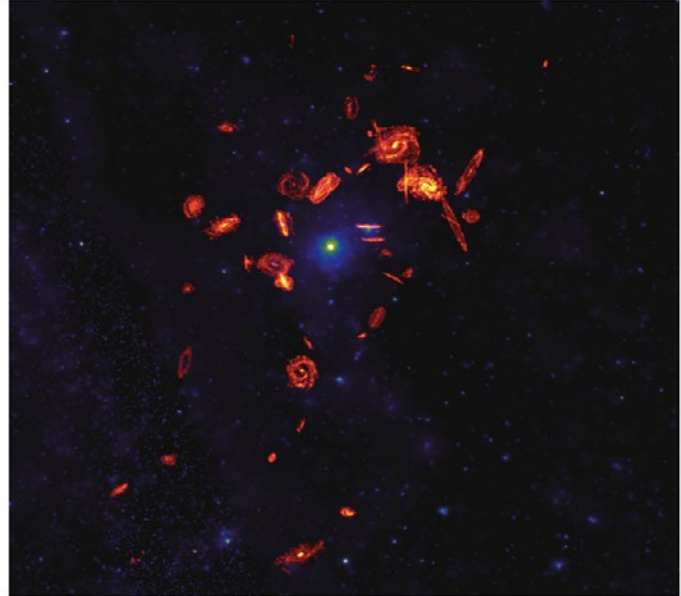

## Time Domain Studies and Fundamental Physics

Astronomers using **ALMA** as the keystone element of the EHT, unveiled the first image of the supermassive black hole Sagittarius A\* at the center of our own Milky Way galaxy, more than a thousand times smaller and less massive than the M87 Black Hole previously imaged. The result is a general relativistic shadow ring of 52 mas diameter, consistent with a Kerr (spinning) black hole of mass  $4 \times 10^6 M_{\odot}$ . One challenge in imaging SgrA\* is its variability, owing to its relatively low mass. In fact, a subsequent analysis showed signs of a hot spot orbiting the black hole. The observations and models suggest this is a bubble of hot gas orbiting SgrA\* clockwise at low inclination, varying in brightness as it travels its orbit every 70 minutes at a projected distance about five times that of the Event Horizon, dimming and brightening as it moves at  $\sim 30\%$  speed of light.

The **VLBA** produced an important measurement of the absolute position of SgrA\* this year (Xu et al. 2022, ApJ, 940, 1), improving the astrometric accuracy to about 0.5 mas, about an order of magnitude better than previous measurements. Also measured was a much-improved proper motion of SgrA\*, found to be  $-3.152 \pm 0.011$  and  $-5.586 \pm 0.006$  mas/year in the easterly and northerly directions, respectively. These measurements are crucial for future studies of general relativistic effects on stellar orbits in the vicinity of SgrA\*.

The **VLA Sky Survey (VLASS)** completed its second epoch of observations in February 2022.

It continues to provide unique insights into the nature of transient radio sources. One recent highlight is the discovery of a candidate extragalactic emerging pulsar wind nebula, VT 1137-0337 (Dong et al. 2022, ApJ, 948, 2). This was identified by comparing VLASS Epoch 1 to the earlier Faint Images of the Radio Sky at Twenty-cm (FIRST) survey. Subsequent follow-up showed that it is a flat-spectrum radio source in a dwarf starburst galaxy that is now slowly fading, making it an excellent candidate for a newly emerged pulsar wind nebula.

A recent highlight from non-transient applications of **VLASS** is the combined use of VLASS and the southern Rapid ASKAP (Australian Square Kilometer Array Pathfinder) Continuum Survey (RACS) to measure the dipole produced by the motion of the Milky Way relative to the cosmic background. In contrast to some previous studies, this joint VLASS/RACS study showed results consistent with those obtained by measuring the dipole in the Cosmic Microwave Background (CMB) with the Planck satellite (Darling, 2022, ApJL, 931, 14).

Betelgeuse ( $\alpha$  Orionis) is the closest red supergiant, on the verge of a supernovae explosion. The star is variable on yearly timescales. In early 2020, the star faded to an historically low brightness. This dimming may be due to dust formation in a major mass loss event driven by photospheric convection, or unusual photospheric cooling. **VLA** 7mm and 1.3cm observations just prior to the dimming find a gas temperature of 2270 K at twice the optical photospheric radius, about 500 K cooler than previous measurements (Matthews & Dupree 2022, ApJ, 934, 131). No giant convective cells were seen, but the observed radio photosphere is inconsistent with a uniform disk, but has large-scale, ring-like structure. The results are consistent with the passage of a major shock wave through the outer atmosphere, possibly driven by large-scale mass ejection.

Large programs at the **VLA** and **VLBA** continue to explore the new window of time domain astronomy in a broad range of physical regimes. These include programs to identify electro-magnetic counterparts to gravitational wave sources discovered by LIGO, and to determine arc-second positions of Fast Radio Bursts (FRB) and monitor repeating FRBs. The VLA participates in the Nanohertz pulsar monitoring program to discover the gravitational wave background from the Big Bang, while the Monitoring Of Jets in Active galactic nuclei with **VLBA** Experiments (MOJAVE) program continues to set the standard for monitoring the temporal evolution of milliarcsecond structure in powerful relativistic radio jets on decadal timescales.

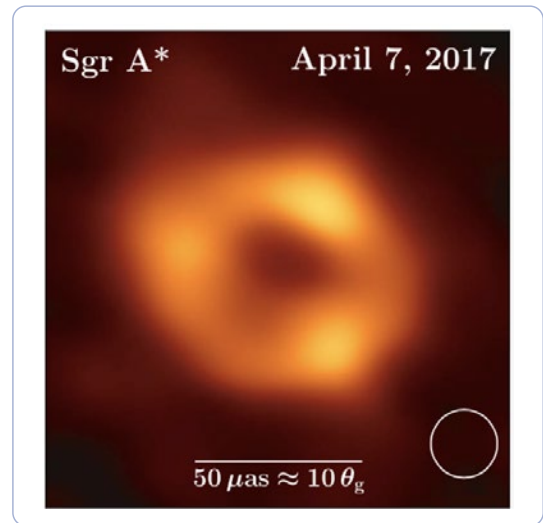

*The EHT (including ALMA) image at 240 GHz of the general relativistic shadow of the supermassive black hole at the Galactic Center, Sgr A\* (EHT collaboration 2022, ApJ, 930, L12).*

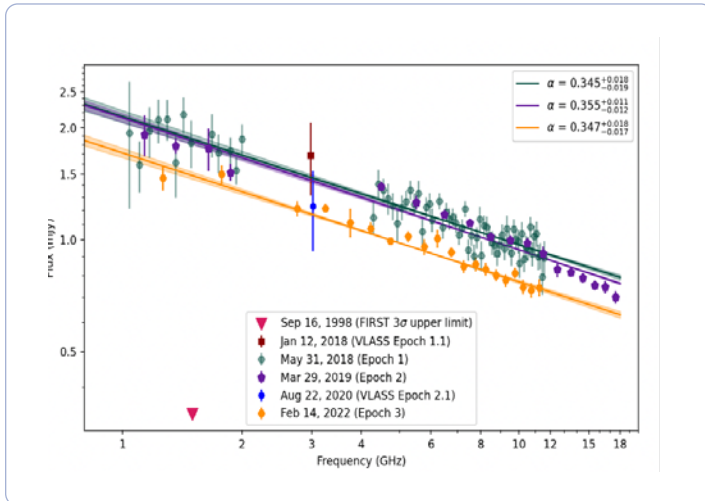

The radio spectrum of the VLASS transient VT 1137-0337. This flat-spectrum radio source appeared between FIRST (1998) and VLASS Epoch 1 (2018) and is seen to slowly fade between 2018 and 2022, making it a good candidate for an emerging pulsar wind nebula (Dong et al. 2022, *ApJ*, 948, 2).

## Solar System and Planetary Science

The NRAO facilities worked in concert with deep space probes and other ground-based facilities to study the physics and chemistry of objects in the Solar System.

Oort-cloud comet C/2014 UN271 (Bernardinelli-Bernstein) was discovered at  $\sim 29$  AU from the Sun (Lellouch et al. 2022, *A&A* 659, 1L), developing cometary activity early with a brightness suggesting a large size. **ALMA** detected thermal emission when the comet was at 20 AU distance from the Sun, from which a surface-equivalent diameter of 137 km is calculated. It is thus the largest Oort-cloud object ever found, (almost twice as large as comet C/1995 O1 Hale-Bopp) and has a normal cometary albedo. Detection of gases is expected in the upcoming years as the comet heads toward a perihelion of 11 AU in 2031.

Solar disk images at  $1700\text{\AA}$  with the Atmospheric Imaging Assembly, and at  $0.85\text{mm}$  with ALMA (Allisandrakis et al. 2022, *A and A*, 661, L4).

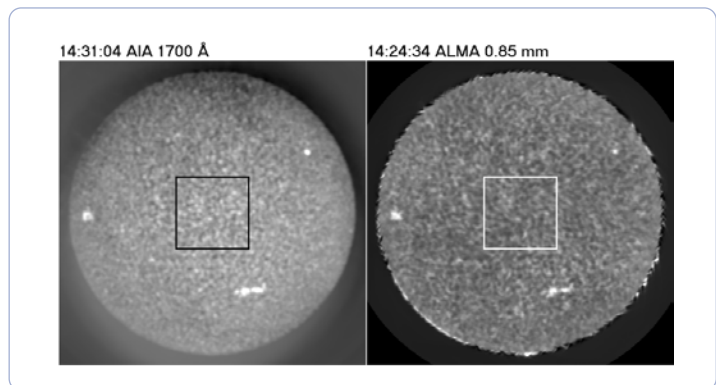

Allisandrakis et al. (2022, *A&A*, 661, L4) present the first full-disk Solar images obtained with **ALMA**, using Band 7 (0.86 mm; 347 GHz). The results show a disk practically devoid of active regions at their  $21''$  resolution. Solar structures on the disk are similar to those in Atmospheric Imaging Assembly images at  $1600\text{\AA}$  and  $304\text{\AA}$ ; they are also similar to negative H $\alpha$  images of equivalent resolution. Small plage regions are about 900K brighter than their surroundings, while the polar coronal holes and small H $\alpha$  filaments are not detectable. The authors deduced a brightness temperature at the center of the disk of 6085 K at 0.85mm, rather than the 5500 K extrapolated from images at 3mm and 1.3mm, an indication that at 0.85mm we are approaching the temperature minimum.

With the ever-increasing number of known exoplanets, many in the habitable zone, understanding the effects of stellar activity (exospace weather), on the potential development of life has become paramount. **ALMA**, working in concert with a multi-wavelength arsenal of space and ground-based telescopes, has measured the faintest flare to date on the nearby (1.2pc distance) M dwarf star, Proxima Centauri, which hosts a planet in the habitable zone (Howard et al. 2022, *ApJ*, 938, 103). The X-ray flare is well within the luminosity range of typical flares on the Sun, while the millimeter emission is two orders of magnitude stronger than typical Solar flares. The findings provide more evidence that millimeter emission is a common feature in weak exo-stellar flares, rising and falling in timescales of seconds. The implied temperature for the corona is  $1.1 \times 10^7$  K.

## Star and Planet Formation and Evolution, and The Search for Life

Thousands of planets are now known, but study of planetary orbits in common binary star systems remains under-explored. Precision (tens of mas) astrometry at 8 GHz with the **VLBA** has traced the 3D structure of the orbits of the binary star system, GJ896AB, consisting of  $0.4 M_{\odot}$  and  $0.2 M_{\odot}$  stars with an orbital period of 229 days at Neptunian separation. Both dwarf stars are magnetically active and have sub-mJy, variable radio emission. The motion of star A implies a  $2 M_{\text{Jup}}$  planet orbiting with a period of 284 days at a Venusian distance. The surprise was that the planet is in retrograde orbit relative to the binary stars. Seeing such a large planet in a retrograde orbit in a very compact binary system challenges theories of planet formation (Curiel et al. 2022, AJ, 164, 92).

*Left: astrometric tracks of the star orbits motion in the binary star system GJ896AB made with the VLBA at 8 GHz. These tracks indicate both the star-star orbit, and the planet-induced motion for star A, with an accuracy of  $\sim$  ten of microarcseconds. Right: schematic of the surprising retrograde orbit for the planet (Curiel et al. 2022, AJ, 164, 92).*

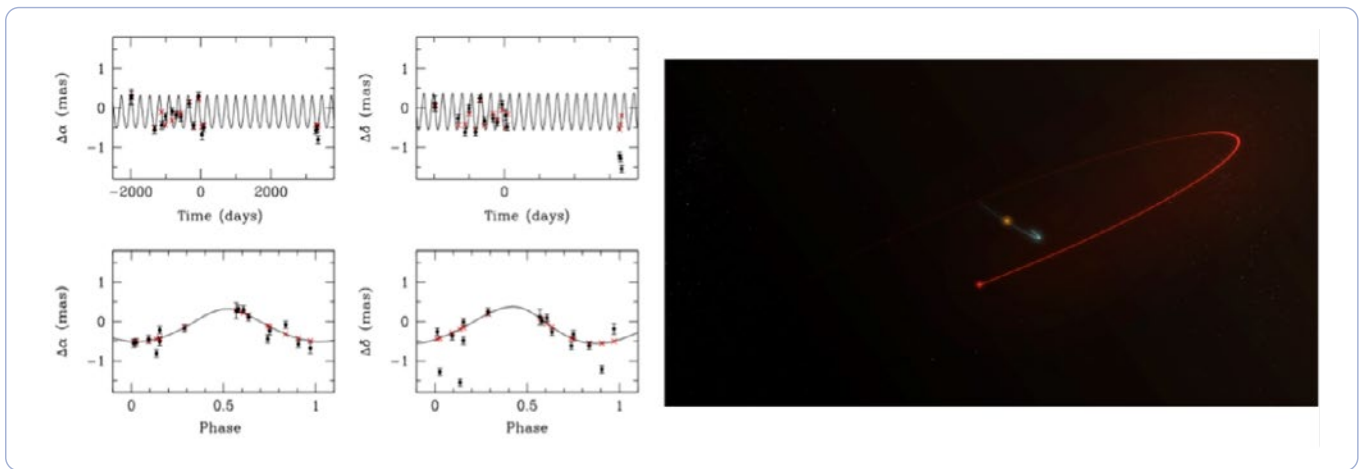

The year 2022 saw the publication of results from the Global View of Star Formation in the Milky Way (GLOSTAR; right; Dzib et al. 2022, A&A, 670, A9) large program at the **VLA**. GLOSTAR is a survey of a large region of the Galactic plane at 4–8 GHz with an unprecedented resolution and sensitivity of  $1''$  and 60 mJy. Almost 1500 radio sources are identified at high significance, including radio stars, planetary nebulae, and HII regions associated with both young stellar objects in clusters and with massive stars.

Results from the **ALMA** Molecules with ALMA at Planet-forming Scales (MAPS) Large Project target were published this year. An important result was the discovery of a circumplanetary disk (CPD) associated with accretion onto a forming planet in the dusty circumstellar disk around the T Tauri star AS209 (Bae et al. 2022, ApJ 934, 20). The CPD is less than 14 AU in size, and is located 200 AU from the parent star. The planet was isolated by velocity perturbations seen in the  $^{13}\text{CO}$  J=2-1 emission. The velocity field suggests kinematic influence of an embedded giant planet of about  $0.1 M_{\text{Jup}}$ ; the data also suggest localized gas heating.

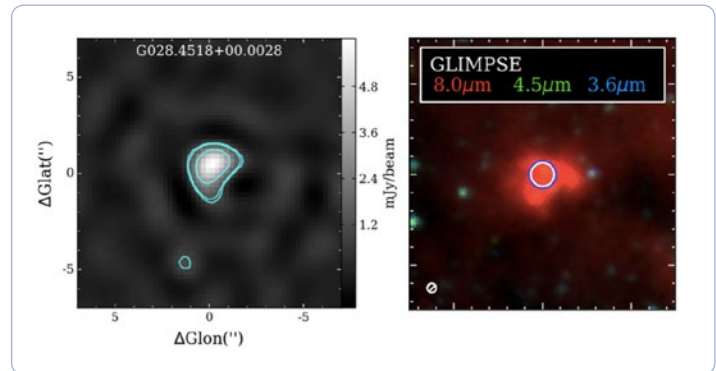

*Images of the Free-Free emission from a Galactic HII region from the GLOSTAR survey at 6 GHz with  $1''$  resolution (left), and in the mid-IR (Dzib et al. 2022, A&A, 670, A9).*

Starless cores are very young, dense molecular clumps seen just before the star itself ignites. TMC-1C, at 140 pc distance, is one of the best studied starless cores, having been observed in multiple molecular transitions. Recent **VLA** measurements of Zeeman splitting of CCS 22.3 GHz line emission from TMC-1C have provided an accurate measure of the magnetic field in the cloud envelope. The 2 mG field is strong enough to affect gas dynamics, implying that the accretion process in the envelope is dictated by ambipolar diffusion across field lines on timescales  $\leq 105$  yrs (Koley et al. 2022, MNRAS, 516, L48).

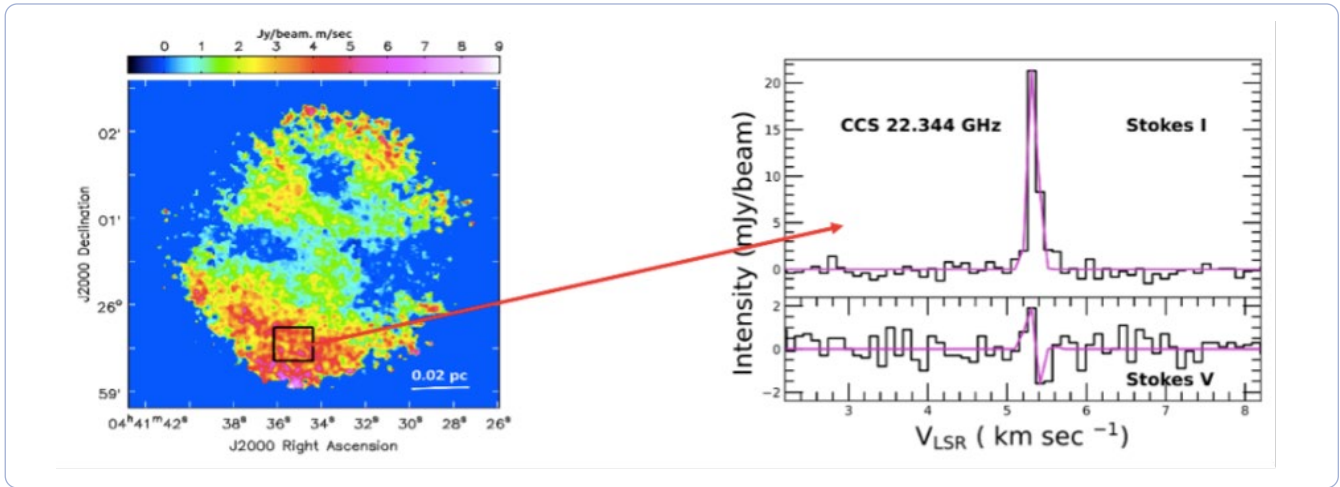

VLA observations of the 22.3 GHz CCS line emission from TMC-1C, plus the Stokes V measurements showing Zeeman splitting (Koley et al. 2022, MNRAS, 516, L48).

The VLA has completed a survey of the M33 galaxy (Tabatabaei et al. 2022, MNRAS, 517, 2) at 1.5 GHz and 6.3 GHz, with resolutions down to 30 pc, sufficient to isolate individual giant molecular clouds (GMC)—the dominant sites for star formation in galaxies. The broadband, multifrequency observations allow for a separation of thermal and non-thermal emission. The results provide the most detailed, dust-unbiased measure of the star formation law relating star formation rate to molecular gas content of GMCs. The non-thermal emission provides details as to the generation of magnetic fields via a turbulent dynamo driven by star formation and supernovae.

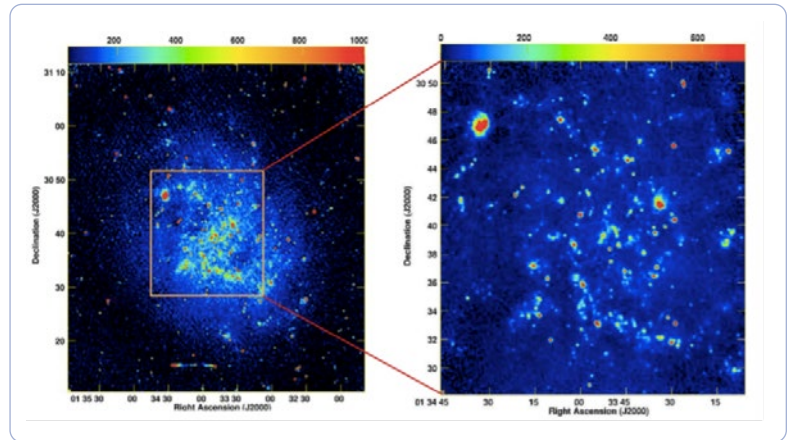

Images of the galaxy M33 at 1.5 GHz, 15" resolution (left), and 6.3 GHz, 9" resolution (Tabatabaei et al. 2022, MNRAS, 517, 2).

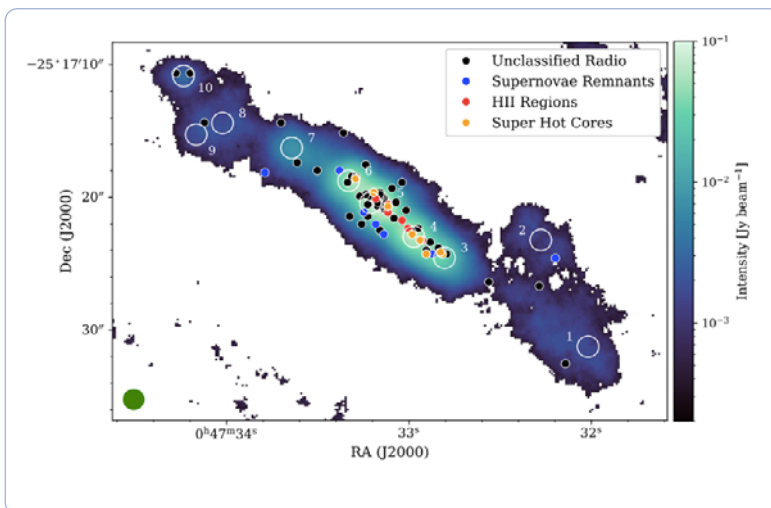

Location of radio continuum sources and super hot cores within the NGC253 CMZ plotted over the 212 GHz ALCHEMI dust continuum emission. Numbered white circles indicate GMCs identified in the ALMA survey (Behrens et al. 2022, ApJ, 939, 2)

The ALMA Comprehensive High-resolution Extragalactic Molecular Inventory (ALCHEMI; Behrens et al. 2022, ApJ, 939, 2) Large Program at ALMA provides a multi-band, beam-matched spectral scan of the Central Molecular Zone (CMZ; 850x340pc) of the starburst galaxy NGC253 at GMC resolution (1" = 17 pc). Five papers this year provide a molecular inventory via reliable templates of chemistry and excitation in one of the closest nuclear starburst galaxies at GMC scales. These papers find major differences in the CMZ relative to the rest of the galaxy disk, including (i) greatly enhanced cosmic ray density, (ii) orders of magnitude lower gas-phase CO<sub>2</sub> abundance at the galaxy center, and (iii) efficient CO<sub>2</sub> sublimation onto ice grains. These differences likely result from the very high star formation rate along the CMZ.

## Galaxies and Galaxy Formation

The **VLA** and **ALMA** provide the unique capability to study the cool gas and dust in galaxies. These are key constituents in fueling star formation, and act as star formation tracers. The **VLBA** provides the complimentary ability to study the bright radio continuum structures on tens of pc-scales, associated with the most distant Active Galactic Nuclei (AGN).

The order of magnitude decline in the cosmic star formation rate density over the last 10 Gyr is a well constrained, but not well understood, phenomenon. It has long been assumed that the cause for cessation of star formation in galaxies is depletion of the molecular gas via strong winds and shocks driven by the star formation itself. SDSS J1448+1010, at  $z = 0.65$ , is a post-merger galaxy which had a sharp drop-off in star formation some 70 Myr ago. **ALMA** observations of CO(2-1) emission show that this system still has plenty of molecular gas, but that the gas has been torn from the main galaxy into a 64 kpc tidal stream due to the recent merger. These observations suggest an alternative mechanism for quenching star formation in galaxies via major mergers, as opposed to just starburst driven dynamics (Spilker et al. 2022, ApJ 936, L11).

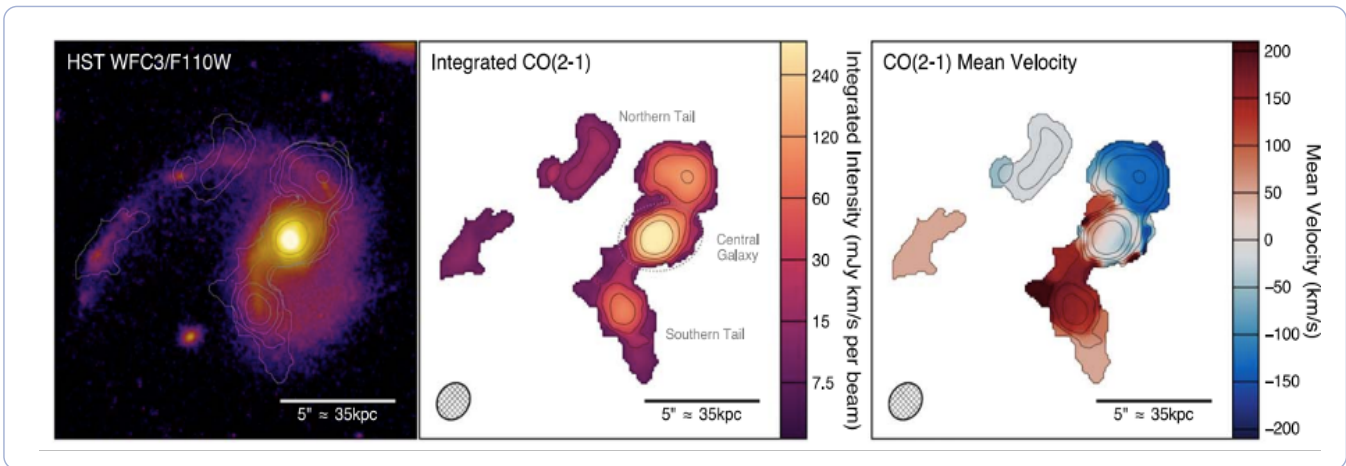

*ALMA observations of CO(2-1) emission from a post-merger, post-starburst galaxy at  $z = 0.64$ . Most of the molecular gas has been stripped into tidal tails extending 64 kpc (Spilker et al. 2022, ApJ 936, L11)*

The **VLBA** remains the only instrument that can probe AGN radio structure down to tens of pc-scales in the most distant galaxies. A recent exciting result came from 1.4 GHz VLBA observations of the low luminosity radio AGN in the  $z \sim 6$  quasar, J2242+0334. These observations imply a highly resolved radio source at 10 mas resolution (60 pc), implying a wind-like radio emitting region, and not a typical high brightness relativistic core-jet. These observations provide clues as to the nature of the radio emission from the lower luminosity radio AGN in the early Universe.

*JWST image of a grand design spiral at  $z = 3.0$ . Center: stellar mass surface density (color) and ALMA 150 GHz dust emission (green contours). Right: ALMA detection of molecular gas (Wu et al. 2022, ApJL, 942, 1).*

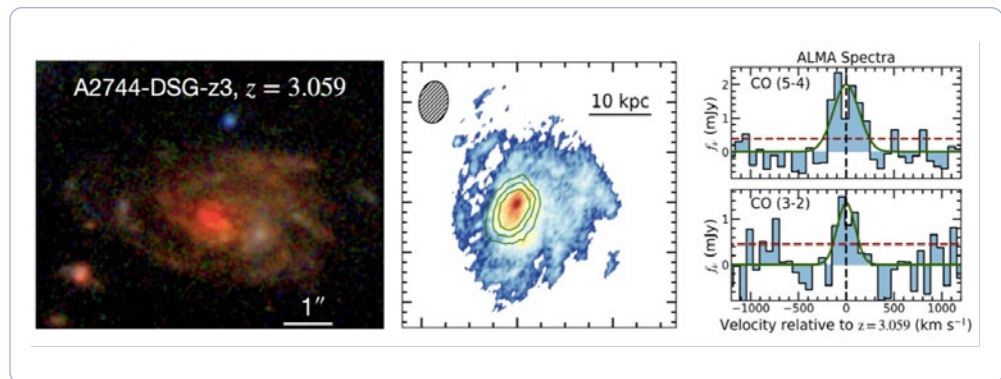



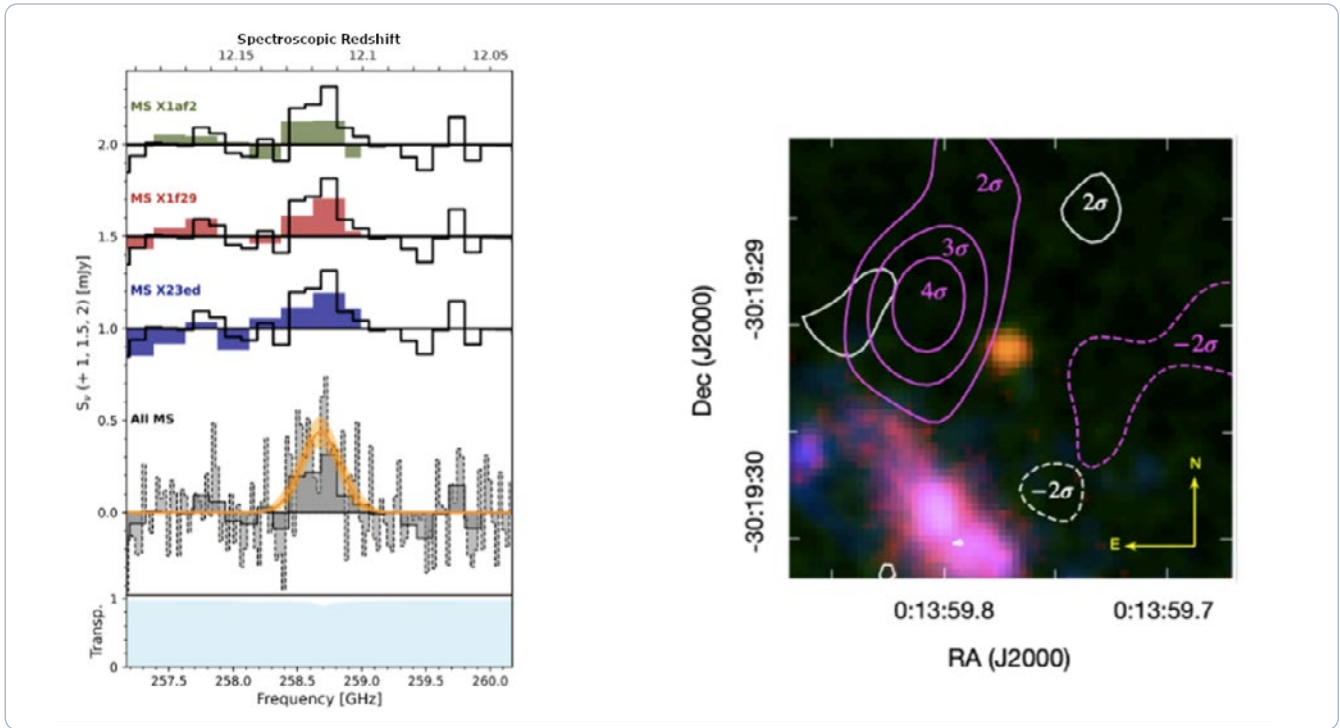

*Tentative [OIII] 88um emission seen by ALMA at 256 GHz, from the  $z = 12.1$  JWST galaxy candidate GLASS-z13 (Bakx et al. 2023, MNRAS, 519, 4).*

**ALMA**, working in concert with the JWST, has identified a dust and molecule rich grand design spiral galaxy at  $z = 3.06$ . The galaxy has a radius of 7 kpc, and a star formation rate of  $85 M_{\odot}/\text{yr}$ , with the dust and star formation revealed by ALMA concentrated in the galaxy center. The CO lines provided the spectroscopic redshift for this galaxy. Existence of an apparently mature, metal enriched, large spiral galaxy just 2 Gyr after the Big Bang challenges mechanisms for galaxy formation in the early Universe (Wu et al. 2022, ApJL, 942, 1).

The **ALMA** Large Programs: Reionization Era Bright Emission Line Survey (REBELS), ALMA Large Program to Investigate C+ at Early Times (ALPINE), and ALMA Lensing Cluster Survey (ALCS), have targeted identifying and performing a first characterization of many of the most luminous star-forming galaxies known in the  $z > 6.5$  universe. REBELS systematically scans 40 bright UV-selected galaxies in a 7 degree square area for bright [C II]158  $\mu\text{m}$  and [O III]88  $\mu\text{m}$  lines and dust-continuum emission. Initial results (Bouwens et al. 2022, ApJ 931, 160) identified 18 objects with [C II] emission, 13 of which also show dust continuum emission. An analysis of these search results vs. Star Formation Rate (SFR) suggests an  $\sim 79\%$  efficiency in scanning for [CII] when the  $\text{SFR}(\text{UV}+\text{IR})$  is in excess of  $28 M_{\odot} \text{ yr}^{-1}$ .

The first ultra-deep fields with the JWST have identified an unexpectedly large number of extreme redshift galaxy candidates at  $z > 10$ , or within 500 Myr of the Big Bang. However, these first galaxy candidates are based on photometric redshifts only—spectroscopic verification of the redshifts remains critical. **ALMA** provides the unique potential to obtain spectroscopic redshifts using fine structure lines. **ALMA** has observed the  $z \sim 12.0$  JWST candidate, GLASS-z13, at 250 GHz, searching for both the [OIII] 83um line and thermal continuum emission. Non-detection of the dust continuum implies a dust-poor galaxy, consistent with the blue optical color. A marginal ( $4\sigma$ ) detection is made of the [OIII] line at  $z = 12.1$ , offset by  $0.5''$  from the optical galaxy. While the probability of this line being noise remains significant (Kaasinen et al. 2022, A&A, 671, A29), the general point remains that ALMA can be an important tool in the spectroscopic verification, and characterization, of the first galaxies candidates from JWST (Bakx et al. 2023, MNRAS, 519, 4).

## Time Domain and Fundamental Physics

The NRAO facilities are critical for imaging Super Massive Black Holes (SMBH) down to scales of the general relativistic shadow of the SMBH. The latest result on the SMBH in M87 (Cui et al. 2023, Nature, 621, 7980, 711) from global VLBI at 3.5mm, anchored by the **VLBA**, **ALMA**, and the **GBT**, shows a 64  $\mu\text{s}$  diameter asymmetric ring, or  $8.4 R_s$ , similar to that seen at 230 GHz by the EHT, but larger in radius by about 50%. The observations also, for the first time, trace the jet down to this ring, possibly indicating a wind driven by the accretion disk. The difference in the M87 ring radius at 90 GHz vs 230 GHz remains a puzzle. Regardless, the fact that the Global 3mm VLBI Array (GMVA) can resolve such a ring, and trace the ring-disk connection down to scales of a few  $R_s$ , opens a new window of opportunity for the **ngVLA** to contribute to future global VLBI experiments at 90GHz, providing dramatic improvements in both the uv-coverage and the total collecting area. Including the **ngVLA** in the GMVA provides baselines that can image structures from 50  $\mu\text{s}$  to  $50''$  at 90 GHz. The **VLBA** has also recently shown a precessional period of 11 years for the M87 jet, consistent with a spinning black hole that induces the Lense-Thirring precession of a misaligned accretion disk.

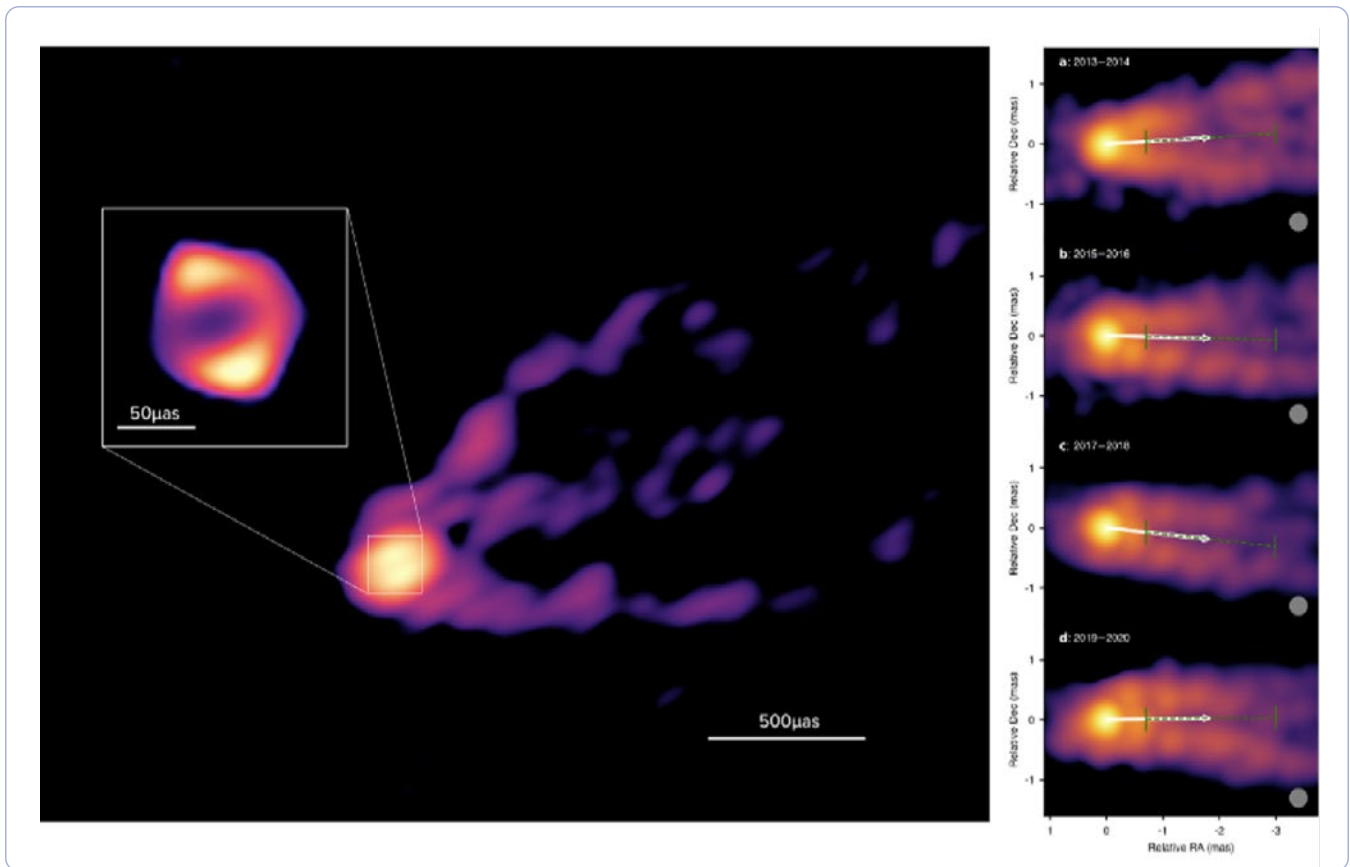

Left: Global 3.5mm VLBI image down to 37 microarcseconds (hyper-) resolution, including the VLBA, GBT, and ALMA, of the SMBH and jet in M87 from scales of a few gravitational radii to a few parsec (Lu et al. 2023, Nature, 616, 686). Right: VLBA 43 GHz observations showing jet precession with an 11 year period (Cui et al. 2023, Nature, 621, 7980, 711).

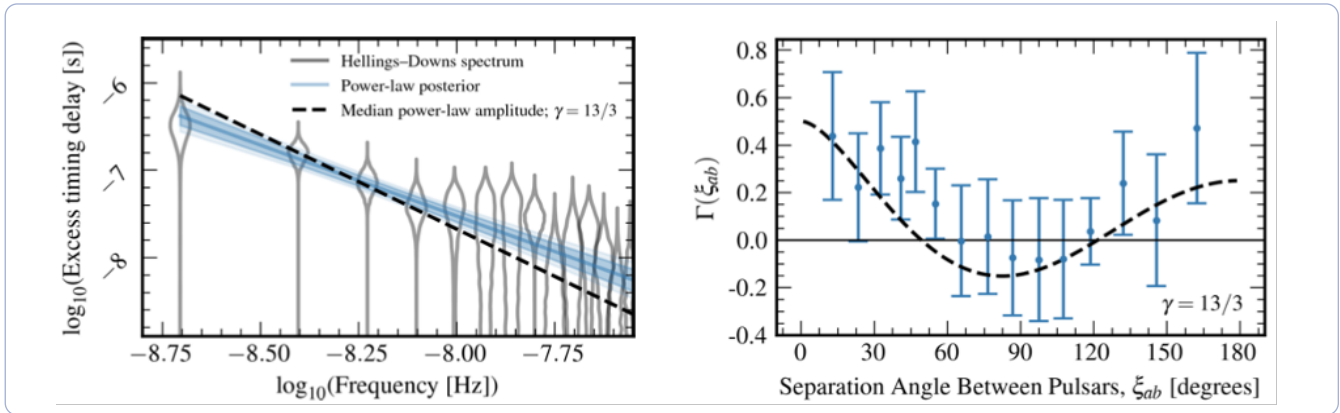

Results from the NANOGrav pulsar timing array showing the spectrum of timing residuals for the pulsar array, and the large scale spatial correlation indicative of very low frequency gravitational waves traversing the Galaxy (Agazie et al. 2023, ApJL, 951, 1)

The NRAO facilities also played a major role in the remarkable discovery of a background of low frequency (nanohertz) gravitational radiation, likely arising from merging supermassive black holes distributed throughout the Universe, with a possible contribution from cosmic structure formation during the inflationary epoch, within 10-32 seconds of the Big Bang. The North American Nanohertz Observatory for Gravitational Waves (NANOGrav; Agazie et al. 2023, ApJL, 951, 1) project is a pulsar timing array, comprised of radio telescopes that monitor millisecond pulsars distributed across the Galaxy. Passage of large scale gravitational waves bend space time between these pulsars and the Earth, leading to a characteristic spatial and temporal signature in timing residuals on yearly timescales for the pulsar distribution. The **GBT** and Arecibo were the primary telescopes involved, with an important contribution from the VLA for low declination pulsars. These results are yet another extraordinary contribution by radio astronomy to our understanding of general relativity and cosmology.

The **VLA** is the state-of-the-art survey of the faint, time variable radio sky. One recent discovery from the VLASS was an extreme radio flare from a likely Tidal Disruption Event (TDE)— the disruption of a star as it falls into a SMBH, in a Seyfert galaxy at  $z = 0.074$ . The radio data include a factor of 100 brightening over a decade, suggesting the formation of a relativistic radio jet over a few years, while X-ray and IR data imply the coeval development of an accretion disk. These data provide further evidence for a fundamental relationship between the formation of relativistic jets and Active Galactic Nuclei (AGN) accretion disks (Somalwar et al. 2023, ApJ, 945, 142).

Time domain and ultra-high resolution large programs continue at the **VLBA** for synoptic imaging of powerful radio jets, including the Monitoring Of Jets in Active Galactic Nuclei with VLBA Experiments (MOJAVE) program on radio AGN, and the Blazars Entering the Astrophysical Multi-Messenger Era (BEAM-ME) program targeting Blazars, likely to be the sources of extragalactic neutrinos. The **VLA** has programs geared toward studying the electromagnetic counterparts to gravitational wave sources.

## Star and Planet Formation and Evolutional Physics, and the Search for Life

The NRAO facilities are uniquely suited for the study of stars, star formation, and planet formation. **ALMA** and the **VLA** remain the primary tools for imaging planet formation in proto-planetary disks, while the **VLBA** has produced the first images of what are likely aurorae and radiation belts associated with a low mass brown dwarf, possibly indicating strong star-planet interaction.

Magnetic fields play an important role in star formation, but direct measurements remain scarce. The **VLA** has demonstrated a new method to measure magnetic fields in star forming clouds using the Zeeman effect in the 38.3 and 38.5 GHz Class II methanol ( $\text{CH}_3\text{OH}$ ) masers (as opposed to the classic 6.7 GHz methanol masers). Zeeman measurements of the massive star forming region NGC 6334 find magnetic fields in the range 8 to 46 mG. Since Class II methanol masers are radiatively pumped close to the protostar, occurring in the accretion disk or the interface between the disk and outflow regions, such fields have significant impact on the dynamics of these disks (Momjian and Sarma 2023, ApJ, 958, 1, 75).

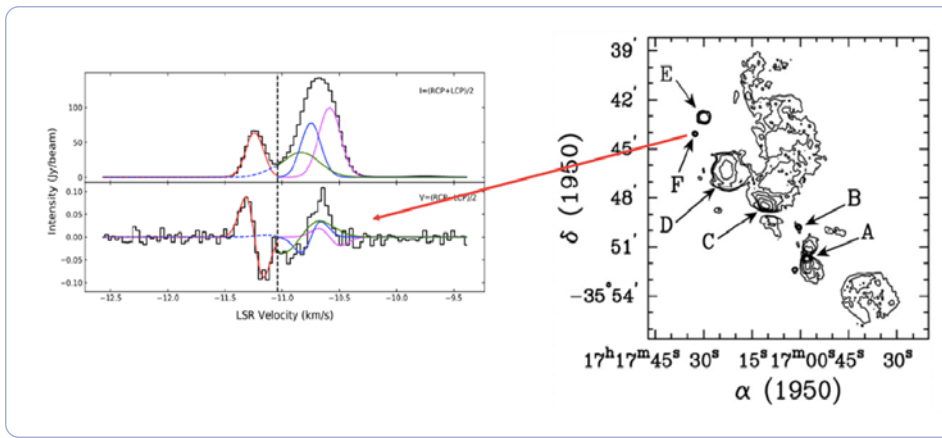
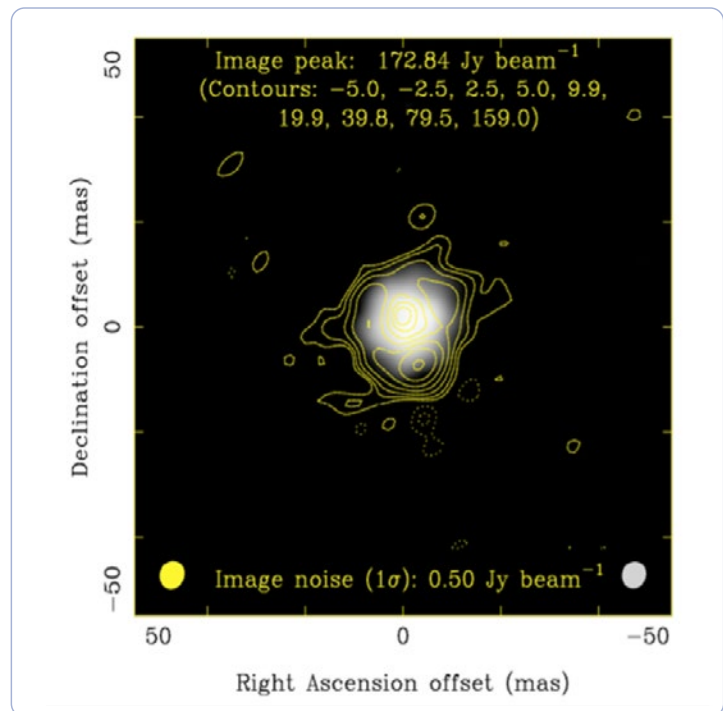

Image of the massive star forming region NGC 6334 at 1.67 GHz plus the Stokes I and V spectra of the methanol lines from feature F, from which magnetic fields are derived from the Zeeman effect (Momjian and Sarma 2023, ApJ, 958, 1, 75).

R Lep is a Mira-type Red Giant variable star, with a period of 445 days at a distance of 471 pc (Asaki et al. 2023, ApJ, 958, 1, 86). **ALMA** was used in 2021 to image the carbon-rich evolved star in Bands 8–10 (397–908 GHz) with baselines up to 16 km. The goal was to validate the calibration, using band-to-band phase referencing with a close phase calibrator. Diffraction limited resolution images were made up to the highest frequencies with resolutions of 5 mas, thereby demonstrating the potential for ALMA to perform very high resolution imaging with the longest baselines at the highest frequencies.

The **ALMA** large program Complex Organic Molecules in Protostars with ALMA Spectral Surveys (COMPASS) is in progress to study complex organic chemistry in star and planet forming regions, while the ALMA survey to Resolve exoKuiper belt Substructures (ARKS) program is targeting exo-Kuiper belt dust emission.

Image of the Mira Red Giant star, R Lep Band 10 HCN maser at 890.8 GHz, plus the continuum emission in greyscale, at 5 mas resolution (Asaki et al. 2023, ApJ, 958, 1, 86).



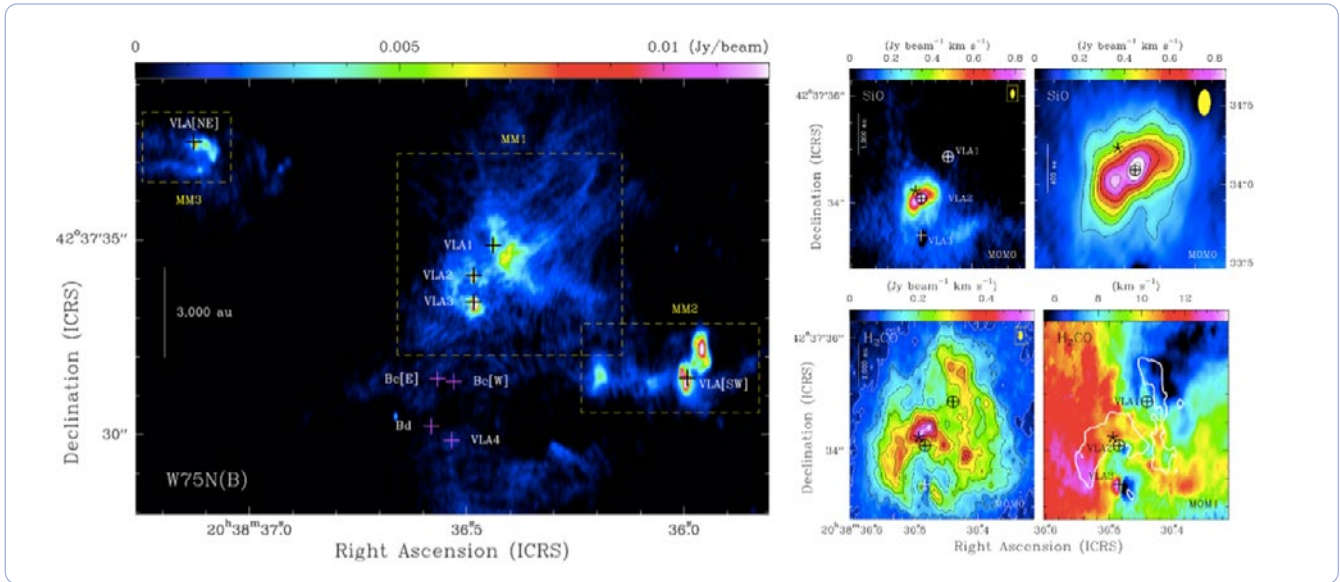

ALMA 1.3mm continuum image of W75(N)B at  $\sim 0.1''$  resolution. Top right: integrated line intensity of SiO emission. Lower right: the H<sub>2</sub>CO emission (Gomez et al. 2023, ApJL, 956, 2, L45).

ALMA has observed the star-forming region W75N(B), containing the massive protostars VLA1, VLA2, and VLA3. VLA2 is an enigmatic protostar associated with a wind-driven H<sub>2</sub>O maser shell, which has evolved from an almost isotropic outflow to a collimated one in just 20 years, with the shell expansion halted by an obstacle located to the northeast. ALMA observations of the 1.3 mm continuum and H<sub>2</sub>CO and SiO emission show a region of  $\sim 30''$  ( $\sim 39,000$  AU) diameter, with 40 compact continuum sources, including VLA1, VLA2, and VLA3. The H<sub>2</sub>CO emission is mainly distributed in a fragmented structure around the three massive protostars. The SiO is highly concentrated on VLA2, indicating the presence of very strong shocks generated near this protostar. The SiO emission is resolved into an elongated structure ( $0.6'' \times 0.3''$ ) perpendicular to the major axis of the wind-driven maser shell. The structure and kinematics of the SiO emission are consistent with a toroid and a wide-angle outflow surrounding a central mass of  $\sim 10 M_{\odot}$ , thus supporting previous theoretical predictions regarding the evolution of the outflow (Gomez et al. 2023, ApJL, 956, 2, L45).



## Galaxies and Galaxy Formation

**ALMA** and the **VLA** are primary tools for studying the molecular gas out of which stars form throughout the Universe, while the ultra-high resolution of the **VLBA** can probe radio structures down to sub-parsec scales in the most distant galaxies.

The **VLA** and **VLBA** have observed HI 21cm absorption toward the radio galaxy 3C84 (Morganti et al. 2023, A&A, 678, A42), at the center of the rich Perseus cluster of galaxies. Broad HI 21cm absorption is detected (500 km/s) with the VLA toward the nucleus at arcsec resolution. The line width suggests that the detected gas is close to the SMBH, but no absorption is detected with the VLBA at 7 mas resolution. Comparison with the circumnuclear disk (CND) seen in CO emission with ALMA, shows similar velocity and spatial structure, suggesting the HI is associated with the fast rotating CND down to 20 parsec radius. The radio continuum providing the background for absorption arises from non-thermal synchrotron emission from the star formation activity in the CND, whose presence has been reported by earlier VLBA studies.

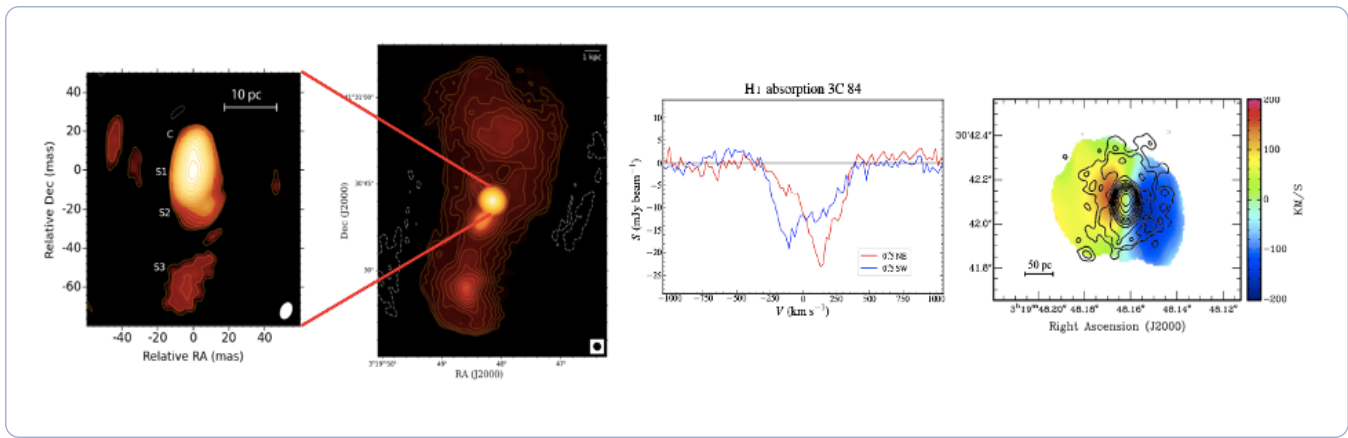

Left to right: VLBA image of 3C84 at 1.4GHz, 7 mas resolution. VLA image at 1.5" resolution. HI 21cm absorption spectra from the VLA in the inner 1" region. ALMA CO velocity field of the circumnuclear disk plus the VLBA 330 MHz image (Morganti et al. 2023, A&A, 678, A42).

Multifrequency **VLA** observations of the prototype Fanaroff-Riley (FRI) radio galaxy, Hydra A (Baidoo et al. 2023, ApJ, 955, 16), reveal extreme Faraday rotation measures (RM), with magnitudes as large as  $-12300 \text{ rad m}^{-2}$ , the majority of which arises in the magnetized thermal cluster gas. The radio emission also depolarizes systematically with decreasing frequency and decreasing resolution. These results can be modeled by a Faraday screen of magnetized cluster gas, external to the radio lobes, with field strengths of a few mG, and with both large scale ordered fields on tens of kiloparsec scales, plus turbulent field structures down to scales of 1 kpc, or less. Such fields have important implications on cluster thermal conductivity and turbulence.

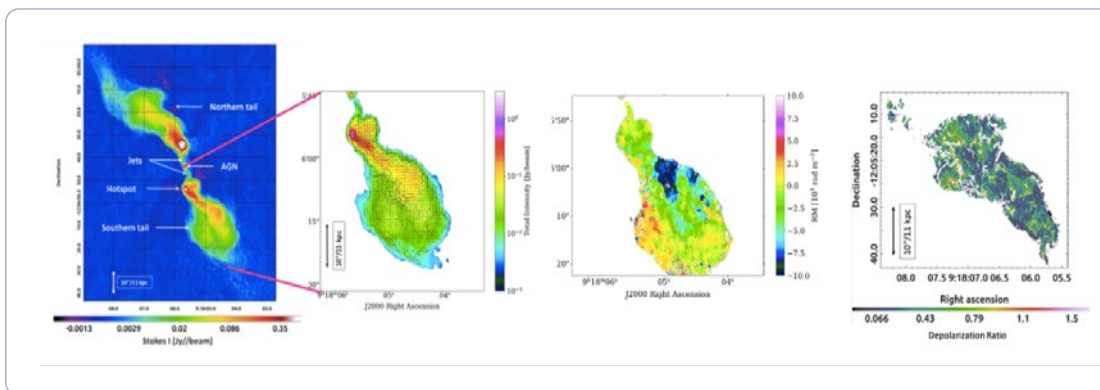

VLA polarimetric imaging of Hydra A, from left to right: total intensity at 2GHz, 1" resolution; magnetic field vectors; rotation measures; depolarization at 6 GHz from 3" to 0.5" resolution (Baidoo et al. 2023, ApJ, 955, 16).

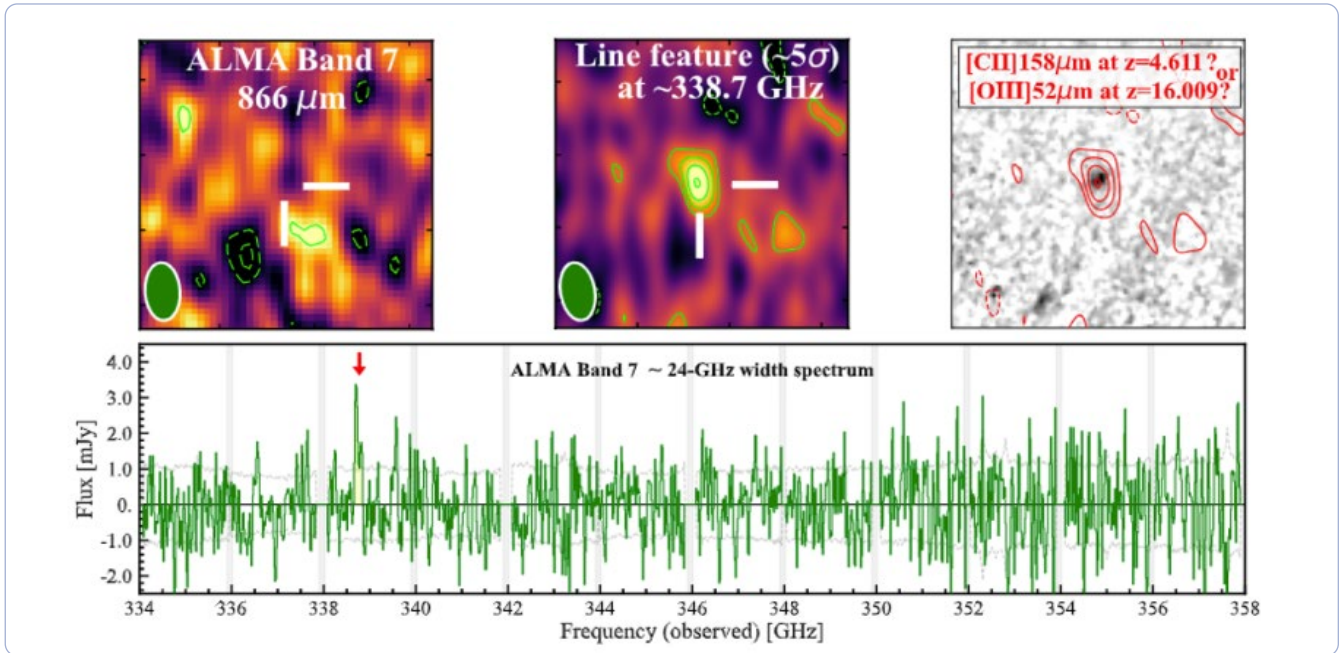

Top: images of dust continuum (non-detection), possible [OIII] 88μm emission, and the JWST near-IR image of a  $z \sim 16$  JWST galaxy candidate (Fujimoto et al. 2023, ApJ, 955, 130). Bottom: ALMA spectrum at Band 7.

One of the most impressive results from JWST has been the discovery of ultra-high- $z$  galaxies, out to  $z \sim 16$ , or a look-back time of 13.5 Gyr (the Big Bang occurred 13.7 Gyr ago). The mere existence of these ultra-redshift galaxies presents an interesting challenge to models of galaxy formation and cosmology. **ALMA** provides the unique ability to image the gas and dust in these first galaxies. **ALMA** is now regularly detecting fine structure line emission from  $z \sim 8$  to 10 galaxies, revealing gas physical conditions, distribution, and dynamics, complimenting JWST studies of the stars and gas. For the current JWST redshift record holder, a candidate galaxy at  $z_{\text{phot}} \sim 16$ , a tantalizing spectral feature seen with **ALMA** may be [OIII] 52μm emission at this redshift, but requires confirmation, since it could be [CII] 157 μm emission at  $z = 4.6$ . Study of the gas and dust in the ultra-high redshift universe promises to become a major growth area for ALMA in the coming years (Fujimoto et al. 2023, ApJ, 955, 130).



Photo by Pablo Carrillo, ALMA

## Galaxies and Galaxy Formation

The VLBI has observed M81\*, one of the closest low-luminosity active galactic nuclei, at 8.8, 22, and 44 GHz. A bright knot in the core-jet is seen at 1.2 mas distance (0.023 pc) from the core. Multi-epoch observations show that the knot has a low apparent speed of 0.1c. X-ray observations show a moderate X-ray flare occurred when the knot launched from the core region. Three possible origins are currently possible: an episodic jet ejection, a low-speed shock wave, or a possible secondary black hole in a binary system (Wang et al. 2023, ApJ, 957, 2, 107).

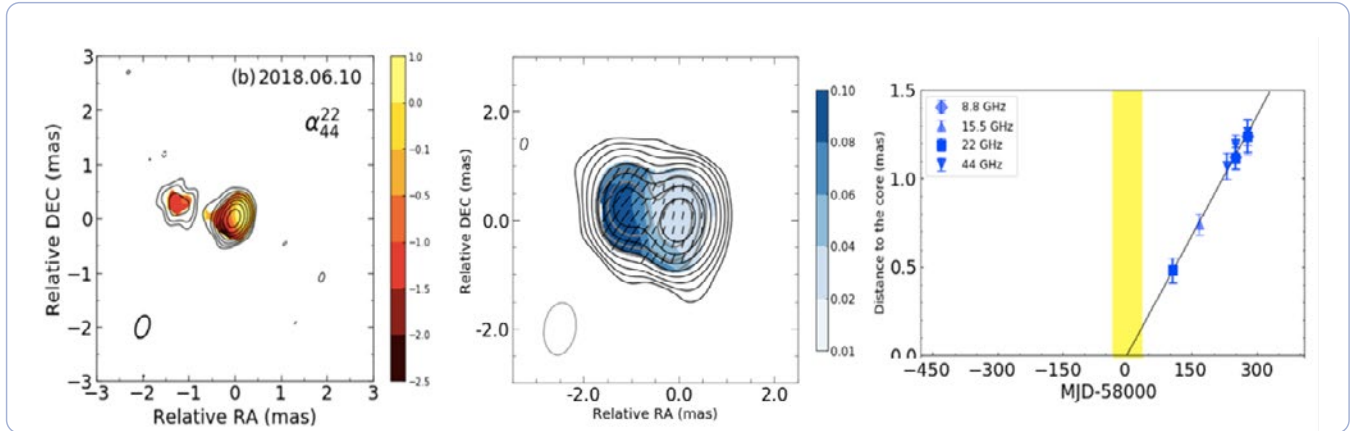

Left: An image of the core and bright knot in the core-jet in M81\* at 22 GHz with a resolution of 0.4 mas, plus the spectral index between 22 GHz and 44 GHz. Center: fractional polarization of the system at 8.8 GHz plus polarization vectors. Right: measure proper motion of the knot (Wang et al. 2023, ApJ, 957, 2, 107).

The first results from the Physics at High Angular Resolution in Nearby Galaxies (PHANGS; Leroy et al. 2021, ApJS, 257, 43) large program at ALMA have appeared, which, in concert with the JWST, has produced spectacular images of the relationship between the molecular gas, dust, stars, and star formation down to tens of parsec scales in a large sample of nearby galaxies. At higher redshift, the ALMA Large Proposal of galactic Cold gAs (ALPACA) program is probing the molecular gas in a large sample of galaxies at the peak epoch of galaxy formation,  $z \sim 1$ .

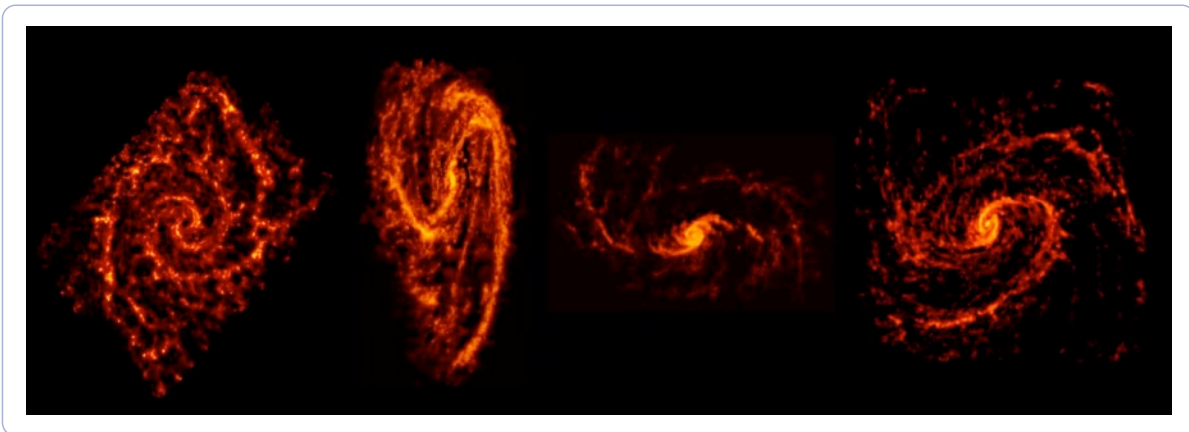

Galaxies imaged with ALMA from the PHANGS large program (Credit: ALMA/ESO/NAOJ/NRAO/PHANGS, S. Dagnello NRAO; Leroy et al. 2021, ApJS, 257, 43).



## Solar System and Planetary Science

The NRAO facilities remain the paramount tools of radio astronomy in the study of planetary science and Solar physics. Working in concert with space missions and ground-based facilities, the **VLA**, **ALMA**, and **VLBA** have contributed in the last year in areas ranging from the energy source of the Solar chromosphere, to winds, storms, and polar vortices in the atmospheres of Saturn, Uranus, Neptune, and Jupiter, to the surfaces of Kuiper belt objects and volcanos on Io.

Callisto is the least geologically active of the Galilean moons of Jupiter (Camarca et al. 2023, *The Planetary Science Journal*, 4, 8, 142). ALMA 343 GHz observations at 0.16" resolution find a mean disk thermal brightness temperature of 116 K. The data suggest a regolith with two very different thermal inertial components. They also identify several thermally anomalous regions, including spots ~3 K colder than model predictions co-located with the Valhalla impact basin and a complex of craters in the southern hemisphere, indicating the presence of materials possessing either a higher thermal inertia or a lower emissivity. A warm region confined to the mid-latitudes may be indicative of regolith property changes due to exogenic sculpting.

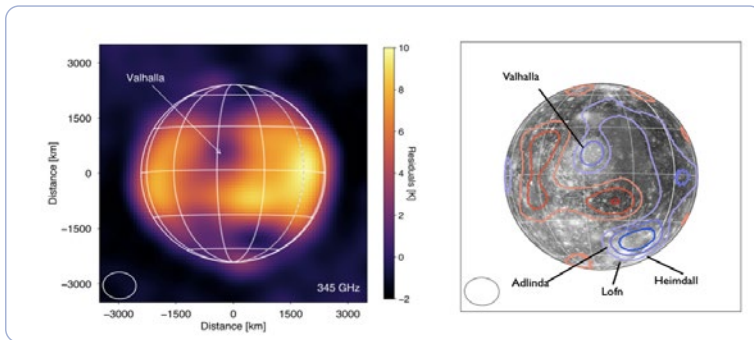

*ALMA 343 GHz image of Callisto at 0.16" resolution with mean disk emission subtracted. Right: ALMA contours plus the albedo map from Voyager and Galileo imaging (Camarca et al. 2023, *The Planetary Science Journal*, 4, 8, 142). A few crater impact regions are indicated, showing higher albedo and cooler mm thermal emission.*

**ALMA** played an important role as a ground facility in the Double Asteroid Redirection Test (DART; Roth et al. 2023, *The Planetary Science Journal*, 4, 11, 206)— a deep space probe designed to investigate the effect of satellite impact on asteroid orbits, as part of the kinetic impactor planetary defense technique program at NASA. ALMA detected thermal emission from the asteroid at 345 GHz both before and after impact. The comparison of the two observations provide the most sensitive measurement of mm-sized ejecta caused by the impact. Depending on the material composition, the ejecta mass was ~ few  $\times 10^7$  kg, representing about 1% of Dimorphos' total mass.

*ALMA 12m and ACA 345 GHz images of the Didymos-Dimorphos binary asteroid system after impact of the DART deep space probe (Roth et al. 2023, *The Planetary Science Journal*, 4, 11, 206).*

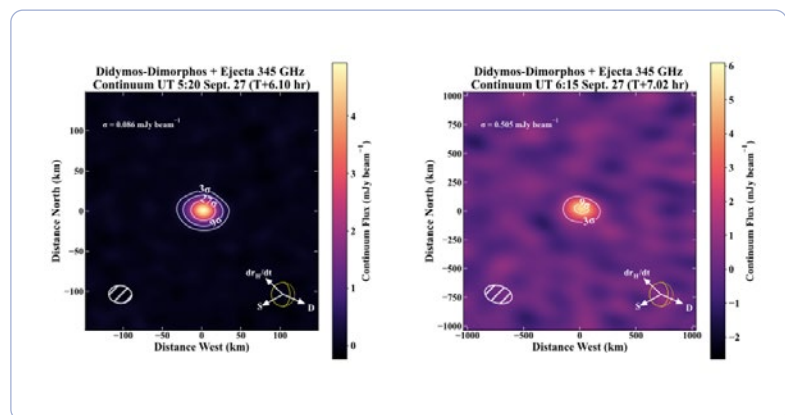

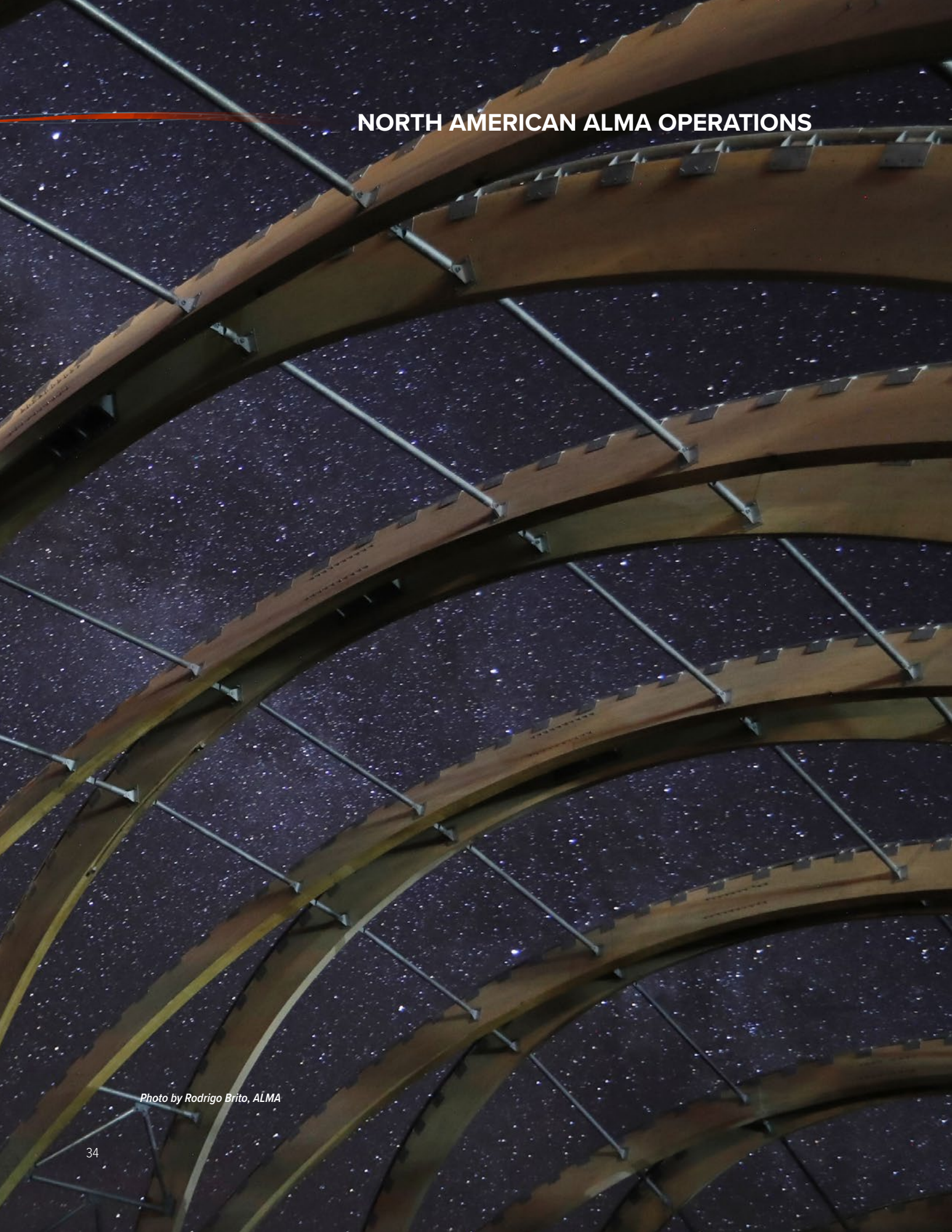
A photograph of the ALMA (Atacama Large Millimeter/submillimeter Array) antenna structure. The image shows several curved, brownish-gold metal ribs that form the shape of the antenna's dish. These ribs are supported by a network of silver-colored metal struts. The background is a dark, starry night sky with numerous small, bright stars. The overall composition is a close-up, low-angle shot looking up at the structure.

# NORTH AMERICAN ALMA OPERATIONS

*Photo by Rodrigo Brito, ALMA*

North American ALMA Operations (NA ALMA Ops) is the NRAO department that provides North America’s scientific and technical partnership support to the international ALMA Observatory and supports the North American community in their use of ALMA. NA ALMA Ops ensures that the North American scientific community has the tools, information, support, and access to make optimal scientific use of ALMA. It also provides scientific, technical, and business support to Observatory operations in Chile in concert with the Joint ALMA Observatory (JAO) staff and international partners, and supports a long-term development program for the technical enhancement of ALMA.

NA ALMA Ops includes four divisions: (1) the North American ALMA Science Center (NAASC); (2) the Offsite Technical Maintenance and Support group, including Construction Warranty support; (3) the NA ALMA Development Program; and (4) the NRAO/AUI Office of Chilean Affairs (OCA).

**NA ALMA Ops focused on the following high-level initiatives from 2021-2023:**

- Support JAO Operations and the NA science community with the Cycles 8,9 & 10 Supplemental Call for Proposals utilizing a dual-anonymous proposal review process and Distributed Peer Review (DPR), including the roll-out of joint proposals;
- Continue to expand the ALMA user base to early career researchers and other astronomy subdisciplines;
- Continue to support the NRAO SRDP strategic initiative while continuing to meet ALMA core deliverables;
- Facilitate NA Principal Investigators (PI) in the publication of their ALMA results by providing and enhancing tools, training, and assistance; to this end, continue support of the NRAO Science Ready Data Products initiative;
- Support the ALMA-wide implementation of the Development Roadmap Wideband Sensitivity Upgrade (WSU), including key NA deliverables; submit the Second-Generation Correlator System for approval by the ALMA Board;
- Initiate the strategic plan to expand the ALMA user-base beyond the radio, millimeter, and submillimeter experts;
- Complete the construction of the Multicancha—the multi-purpose staff recreation center at the ALMA Operations Support Facility (OSF);
- Prepare for the next collective bargaining agreements with the two unions of ALMA local staff
- Participate in the implementation of the ALMA 2030 Development Roadmap through NA projects and collaborations, and collaborate on long-range visions for ALMA.
- Enhance and expand PROVOCA, the successful mentoring program that promotes greater participation and retention of girls and women in Science, Technology, Engineering, and Mathematics (STEM) careers.

From 2021-2023, the NAASC focused on the restart of Cycle 7 observations, followed by the successful execution of Cycle 9 and the Cycle 10 Call for Proposals. The NAASC continued to prepare for new ALMA capabilities which will stem from the ALMA 2030 development roadmap, and continued to develop a strategic plan for a shift in priorities (and possible expansion into new areas of software and heuristic development) through the 2030s. NAASC staff continued to focus on user- and telescope-facing tasks, data analysis, and development.

## A New Multicancha Facility

During the operations phase of the Observatory, the OSF is the workplace of some ALMA astronomers and of the teams responsible for maintaining proper functioning of all the telescopes. The ALMA team working at the telescope at the OSF generally work on a turno, living on-site for eight days or so at time before rotating back to their homes. To support the health and welfare of these workers, ALMA North America has recently completed a covered multi-court indoor sports facility, the Multicancha, providing activity space sheltered from the tropical sun and from the dust-bearing winds that scour the site. An Opening Ceremony for the Multicancha was held March 14, 2023, following the March 13 ALMA 10th Anniversary Celebration, also at the OSF.



# NORTH AMERICAN ALMA OPERATIONS

## North American ALMA Science Center

Coming out of the COVID-19 pandemic, the NAASC made excellent progress on its strategic goals for 2021-2023. The ALMA Community Support group interfaces with the North American ALMA user community and supports initiatives such as ALMA Ambassadors and the face-to-face visitor program. The primary goal of the Community Support Group is to improve the end-user experience of ALMA for the scientific community. In FY2023, the ALMA Community Support group performed its core services and planned initiatives, fulfilling its interface role with the North American ALMA user community and the astronomy community at large. Community outreach activities, including initiatives aimed at expanding the ALMA user base, were reinforced by the creation of a dedicated community programs team and new hires.



*ALMA Cycle 10 Ambassadors during the February 2023 training at NRAO headquarters in Charlottesville, VA.*

**Community Support and Outreach:** The NAASC hosts multiple outreach forums designed to increase and facilitate the use of ALMA by the scientific community. The NAASC continued to execute a portfolio of initiatives engaging the astronomy community at large. A new dedicated Community Programs team was established to strategically address three main outreach goals: supporting the general astronomy community in their use and understanding of ALMA and WSU; facilitating scientific productivity; expanding the user base by increasing geographic and scientific participants.

The NAASC organized, supported, and hosted numerous events across North America and Chile to inform, support, and train astronomers on how to propose for and use ALMA data. The flagship ALMA Ambassadors program continued based on the incredibly successful format developed by NRAO/NAASC scientists. The program trains a yearly cohort of early career astronomers to hold proposal preparation and data reduction workshops at their institutions for new and prospective users. The NAASC also hosted a Special Session at the American Astronomical Society (AAS) meeting in Seattle, Washington, January 2023 on the Wideband Sensitivity Upgrade (WSU).

Events were held in webinar form online in 2021, transitioning back to in person events in 2022-2023. The NAASC was a major contributor and/or host to many webinars, workshops, and scientific meetings. The list below summarizes the community contributions hosted by the NAASC, including those hosted and run by the ALMA Ambassadors.

### 2021 Webinars

- *Extragalactic magnetism with ALMA and SOFIA*, Enrique López-Rodríguez (KIPAC/Stanford)
- *Far-infrared Ionized Carbon Emission: the Missing Piece of the ISM Puzzle*, Alberto Bolatto (University of Maryland)
- *Accretion outburst from a massive protostar: a sequence of extraordinary observational results*, Todd Hunter (NRAO)
- *The Force Awakens: How a Growing Black Hole Affects its Host Galaxy*, Allison Kirkpatrick (Kansas University)
- *Tracing the formation/evolution of planetary debris disks with multiwavelength approaches*, Kate Su (University of Arizona)
- *Mapping the surfaces properties of icy and rocky Solar System worlds*, Katherine de Kleer (Caltech)

## 2022 Events

- *Our Galactic Ecosystem: Opportunities in the Infrared and Beyond*, Lake Arrowhead Lodge, CA, February 2022
- *ALMA Support for the 18th Synthesis Imaging Summer School*, Socorro, NM, May 2022
- *75th International Symposium on Molecular Spectroscopy*, in Champaign, Illinois, June 2022

## 2023 Events

- *exoALMA Large Program Workshop* (Boston, MA)
- *DECO Large Program Workshop* (Charlottesville, VA)
- *Gordon Research Conference on Origins of Solar Systems* (South Hadley, MA)
- *76th International Symposium on Molecular Spectroscopy* (Champaign-Illinois, IL)
- *COMPASS Large Program Workshop* (Ann Arbor, MI)
- *Kavli-AUI Symposium, Astrochemistry VIII* (Traverse City, MI)
- *New Era of AGN Science with the Vera C. Rubin LSST* (Charlottesville, VA)
- *The Evolution of Gas in and around Galaxies* (Stanley, ID)

## ALMA Ambassadors, Proposal Preparation, and Data Processing Events

<b>Dates</b>	<b>Location</b>	<b>Ambassador</b>
March 28, 2022	Stanford University	Wren Suess
March 29, 2022	University of Maryland	Nathan Roth
March 29, 2022	Montana State University	Hansung Gim
March 30, 2022	Yale University	Cheng-Han Hsieh
April 01, 2022	Northwestern University	Tarraneh Eftekhari
April 02, 2022	University of Alabama	Hansung Gim
April 08, 2022	University of Arizona	Fengwu Sun
October 05, 2022	University of Florida	Allison Towner
October 05, 2022	University of Arizona	Fengwu Sun
October 11, 2022	Montana State University	Hansung Gim
October 18, 2022	University of Maryland	Nathan Roth
October 24, 2022	Stanford	Wren Suess
October 26, 2022	University of Colorado, Boulder	Hayley Roberts
October 26, 2022	CfA / Harvard University	Charles Law
October 28, 2022	Northwestern University	Tarraneh Eftekhari
April 18, 2023	MIT Haystack	Dongjin Kim
April 14, 2023	University of Texas, Austin	Arianna Long
April 14, 2023	Universidad Católica del Norte	David Rebolledo
April 18, 2023	Canadian Inst. for Theoretical Astrophysics	Jiayi Sun
April 19, 2023	University of Massachusetts, Amherst	Sinclair Manning
April 20, 2023	West Virginia University	Emily Moravec
April 20, 2023	University of British Columbia	Adam Dong
April 26, 2023	IPAC/Caltech	Marion Villenave
April 27, 2023	Universidad Diego Portales	Miguel Vioque
Sept 13, 2023	University of British Columbia	Adam Dong
October 05, 2023	West Virginia University	Emily Moravec
October 05, 2023	Villanova	Dylan Paré
October 19, 2023	National Solar Observatory	Johnathan Stauffer
October 23, 2023	JPL, Pasadena, CA	Marion Villenave

# NORTH AMERICAN ALMA OPERATIONS

**User Documentation:** ALMA end user documentation preparation is an annual task in which the NAASC takes a leading role supporting the JAO. The documentation preparation and review include the upcoming Call for Proposals, Proposer's/Users' Guide, ALMA Primer, ALMA Technical Handbook, Guide to the NA ARC, software user guides (including CASA Guides) and additional documentation on how to access NAASC services. The team participates in the international ALMA working groups that prepare these documents for the user community. NAASC staff again took a lead role in the preparation of the new Cycle 10 Call for Proposals and user documentation, including all updates and edits to the ALMA Science Portal. As in Cycles 8 and 9, the Cycle 10 proposal process included dual-anonymous and Distributed Peer Review (DPR). The NAASC provided clear instructions to proposers on the impact of DPR and dual-anonymous review on proposal construction and processing.

**Face to Face Visitor and Helpdesk Support:** The NAASC provides overall management of ALMA Helpdesk activities including routine ticket reviews, enforcement of ticket service-level agreements, and formulation of new Knowledgebase articles based on user questions. Face-to-face (f2f) support includes hosting up to one to two data processing teams from NA institutions per week at the NA ALMA Regional Center (ARC) in Charlottesville, VA or at the National Research Council (NRC) in Victoria, British Columbia, Canada. The visiting teams work with the NAASC data analysts and NAASC or NRC scientific support staff on various aspects of data processing and image analysis. In FY2021, the NAASC continued hosting face-to-face (f2f) visitors despite the COVID-19 pandemic. This was managed by moving the visits virtually and then f2f when scientific visitors were allowed back into NRAO facilities. The NAASC was able to host seven virtual f2f visitors with the first in-person visit in Q4 FY2021. FY2022, as the global pandemic subsided, the NAASC resumed data reduction visits in the traditional, f2f format, as well as continuing to offer f2f visits in the virtual format. In FY2023, the NAASC continued to offer data reduction visits in the traditional in-person format as well as virtually.

**Data Processing:** A main objective of the Data Processing Workflow is to deliver fully calibrated data and representative images of ALMA standard observing modes to PIs within 30 days of the date of last successful execution on the array. In FY2023, NAASC staff continued to work closely with the JAO teams to deliver to the NA ALMA user community an average of 26 datasets per week and a peak rate of 35 data sets per week in some quarters. From Q1 through Q4 FY2023, the staff delivered 229, 456, 403, and 271 data sets, respectively, where Q1 was lower owing to the cyberattack and Q4 lower owing to long baselines. This rate of delivery maintained pace with data acquisition to prevent a data processing backlog. The NAASC continued to coordinate and manage the calibration, imaging, and delivery of PI data products through the ALMA Archive and continued to provide North American PIs access to calibrated Measurement Sets (MS) and value-added data products generated by the ALMA Data Mining Toolkit (ADMIT). The team provided summary reports on data processing and delivery as needed and projections of anticipated workload on a quarterly basis.

**Telescope Interface and Diagnostics:** The Telescope Interface and Diagnostics group is the NAASC technical liaison to the JAO. Communication and interaction between the ARCs and the JAO via this group is of critical importance to ALMA project success. The ALMA Telescope Interface and Diagnostics group was responsible for the activities described below.





**Phase 2 Group (P2G):** NAASC P2G staff provide the technical expertise to review and set up Phase 2 materials (Scheduling Blocks, or SBs) submitted by NA PIs for an observing cycle. This includes modifying SBs that require expert technical input, coordinating with the JAO to request calibrator searches, and ensuring that all SBs are ready to run on the telescope. In FY2023, P2G staff conducted the technical assessments of approved Cycle 10 programs. During a cycle, the NAASC staff also provide any SB changes required following an approved change request or other edits requested by the PI or as needed for scheduling, and also support new programs approved mid-cycle, including Director’s Discretionary Time (DDT), supplementary calls, and Observatory-type projects. In preparation for an upcoming cycle, NAASC staff participate in software testing of the ALMA Observing Tool (OT) and relevant end-to-end tests, as well as software such as the Project Tracker, and closely coordinate with the JAO, other ARCs, and OT working group on developing P2G best practices at the annual P2G face-to-face meeting.

**Contact Scientists:** NAASC staff provide oversight and support for all the approved NA ALMA PI programs for an observing cycle. This includes ensuring PIs have reviewed (and, if necessary, approved) their projects for scheduling prior to the start of a cycle, and, if needed, providing communication between PIs and the JAO during a cycle. NAASC staff also provide oversight of the status of PI SBs and, if needed, coordinate with the JAO on scheduling issues. Throughout FY2021-2023, NAASC staff continued to act as Contact Scientists (CS) and liaisons to the NA ALMA PI observing programs in support of Cycle 8 and 9 observations, and in preparation for Cycle 10 observations.

**Telescope Operations in Chile:** The NAASC coordinates with the JAO and other ARCs on scheduling of Astronomer on Duty (AoD) shifts to Chile and provision of AoDs in support of ALMA telescope operations in Chile. In the past, the NA ARC has been responsible for covering a minimum of 14 shifts in a calendar year. As a result of the pandemic, in 2021 the JAO began use of the Santiago Control Room Extension to provide remote observing with ALMA, which resulted in a significant change in AoD staffing. All Cycle 8 observing programs were assigned a contact scientist and NAASC staff

# NORTH AMERICAN ALMA OPERATIONS

provided support to the NA ALMA PI observing programs throughout FY2021. In FY2022, as the pandemic subsided and international travel became possible again, the NAASC resumed AoD shifts for the first time in three years, including AoD shifts from the Santiago Control Room Extension. In FY2023, the NAASC provided AoD shifts by NA ARC staff through Q1-Q4.

**Telescope Diagnostics:** The NAASC continued to play a critical role in the JAO technical and diagnostics-related meetings and teleconferences, such as the Control System and Correlator Group weekly meetings and software readiness review meetings. In FY2022-23, the NAASC continued to coordinate with the JAO on troubleshooting issues and problems found with the telescope systems or in data collection and analysis. NAASC staff also continued to maintain a close interaction between data processing and the telescope diagnostics teams at the JAO to ensure all problems are reported and tracked efficiently.

NAASC staff played an integral role in the identification and subsequent heuristic development of the so-called “renormalization issue.” In short, interferometers require data normalization for correct flux scaling. This normalization is performed by using the data from each individual antenna (the autocorrelations) in combination with the data from each antenna baseline pair (the crosscorrelations). The crosscorrelation data of each baseline are divided by the power of the autocorrelation data of each antenna in the pair. The autocorrelation data are commonly averaged over all observed frequencies. However, at ALMA, we instead divide the crosscorrelation data by the channelized autocorrelation data (i.e., the autocorrelations as a function of frequency). This enables us to obtain extremely flat amplitude baselines without having to perform fits to the data. If an observation targets a very bright, extended source (like carbon-monoxide emission in a star forming region for example) that can be easily detected by a single dish observation, that emission may show up in the autocorrelation data as well. This then leads to an incorrect normalization value in those channels where the emission was detected and therefore an under-scaling of the flux values in those channels.

## North American ALMA Development

### Completed Development Projects

#### Studies Completed in FY2021:

**Wideband Low-Noise Balanced IF Amplifiers for ALMA Band 6, with Future Application to ALMA Bands 3–10 (Lead Institution: NRAO):** This study continued the development of a balanced 4–12 GHz IF amplifier which will have lower noise than the current IF amplifiers and will not require an isolator. The balanced amplifier will have twice the bandwidth of the IF amplifiers in most of the ALMA receivers, which will allow simultaneous measurement of spectral lines more widely spaced in frequency than is currently possible.

**Band 6v2 SIS Mixer Development (Lead Institution: NRAO):** This study continued the development of a Superconductor-Insulator-Superconductor (SIS) mixer/preamplifier combination for a future ALMA Band 6 receiver upgrade. This effort included using SIS junctions with an aluminum nitride tunnel barrier instead of the usual aluminum oxide barrier, single-ended versus balanced sideband-separating (2SB) mixers to reduce LO sideband noise, IF amplifiers with and without ferrite isolators, balanced IF amplifiers (which require no isolator), a substantially expanded IF bandwidth, and a modestly expanded RF bandwidth (beyond 211–275 GHz) to cover additional spectral lines.

**Investigation into Improvement of FE LO Sideband Noise for ALMA Band 6 (Lead Institution: NRAO):** This study was a follow-up to the Band 6v2 CoDR panel recommendation to improve the LO sideband noise will enable simplification of the proposed new receiver architecture. Specifically, the Band 6v2 panel report suggests, “...investigate the options of using a single-ended mixer (with improvement of the local oscillator noise level) and using a single-ended LNA with isolator.”

**TALON-based Correlator (Lead Institution: NRC-Herzberg):** This study investigated the potential of integrating a TALON Frequency Slice Architecture (FSA) Correlator/Beamformer (CBF) into the ALMA Observatory. This includes detailing the capabilities, rack space, and power estimates for a CBF that handles the existing bandwidth and number of antennas and potential expansion for additional bandwidth and antennas. It will investigate existing ALMA CBF interfaces and document how a TALON FSA CBF could be integrated with minimal impact to ALMA systems.



**Upgraded ALMA to Imaging Planet-Forming Disks (Lead Institution: California State Univ. Northridge):** This study quantified the potential of an upgraded ALMA with improved angular resolution and continuum sensitivity, as required to detect substructures expected in planet-forming disks with sub-Astronomical Unit (AU) resolutions at wavelengths <1 mm, and with -1 AU resolution at wavelengths >1 mm. This study could have high impact on the planet formation and exoplanets field, as it would quantify the potential of an upgraded ALMA to observe and characterize forming Earth-like planets at their interaction with the natal disk.

**ALMA Reduction in the CANFAR Data Environment (Lead Institution: NRC-Herzberg):** Since the size of ALMA data sets can be a major barrier, this research built off the computing infrastructure and interfaces developed by the successful Canadian Advanced Network for Astronomical Research (CANFAR) science platform. The prototype performance and usability was fully tested to determine necessary changes, increase the prototype functionality, test the backend technology, and determine additional steps to scale out its deployment.

**Band 6v2 SIS Mixer-Preamp Development (Lead Institution: NRAO):** This study continued the development of the components for a future ALMA Band 6 receiver upgrade, referred to here as Band 6v2. The goals are: (i) to increase the IF bandwidth from the present 4 GHz per sideband per polarization to 12 GHz (4–16 GHz) or 16 GHz (4–20 GHz); (ii) to reduce and flatten the noise temperature across the full IF band; and (iii) to expand the usable RF band from the current 211–275 GHz to 211–280 GHz. While the current ALMA correlator and IF transmission system can only accommodate 4 GHz per sideband per polarization, the new receiver will take advantage of future upgrades enabling increased bandwidth.

#### **Studies Completed in FY2022:**

**Extending IF Bandwidth of the Existing Band 6 SIS Mixers (Lead Institution: NRAO):** This study reports on a preliminary look at how the planned increased bandwidth of Band 6v2 may affect its overall noise performance compared to the original Band 6 receivers.

**ALMA Band 6v2 Mixer-Preamp Development (Lead Institution: NRAO):** This study investigated several options for the ALMA Band 6v2 receiver upgrade architecture, the results of which helped guide the Band 6v2 Receiver upgrade proposal that was reviewed by the ALMA Board in Q1 FY2021.

**Regularized Maximum Likelihood (RML) Techniques for ALMA Spectral Line Imaging (Lead Institution: Penn. State Univ.):** This study developed and implemented RML algorithms for ALMA spectral line imaging, focusing on achieving high image fidelity when utilizing multi-configuration aggregate datasets. As the ALMA archive continues to mature, techniques that can accurately image large and diverse quantities of data will drive science forward in key areas that require sensitivity and angular resolution, such as the kinematic detection of planets in protoplanetary disks and astrochemical domains.

**ALMA Archive Research using ADMIT (Lead Institution: Univ. of Maryland):** This study augmented the existing ALMA Data Mining Toolkit (ADMIT) capabilities with the creation of a prototype Science Query Database that enables broad science driven queries of ALMA projects. This will enable science discovery with ALMA archival data by enhancing users' ability to identify, access, and examine relevant data sets through database access to scientific and observational metadata.

**Link CASA to the Astropy Ecosystem (Lead Institution: Univ. of Florida):** This study explores how to make ALMA data more accessible to the broader astronomical community by establishing a rich suite of analysis tools that extend the existing CASA toolkit. This study intends to make the Astropy Ecosystem accessible from within CASA and produce tools for interoperability with CASA. This project will demonstrate a testing framework to ensure compatibility between CASA and community-provided tools. It will develop compatibility tools to convert files of different formats to and from CASA formats.

# NORTH AMERICAN ALMA OPERATIONS

## Studies Completed in FY2023:

### Extending New Imaging Techniques from the EHT to ALMA (MIT Haystack Observatory)

**Ubiquitous Quantum-Limited Wideband 4-Kelvin Amplifiers (NRAO):** Traveling-wave kinetic-inductance parametric amplifiers (TKIPs) are a promising new technology to improve the bandwidth and sensitivity of radio astronomical receivers, especially at millimeter/submillimeter-wave frequencies, where the theoretical limits of SIS-based receivers have almost been realized. Therefore, successful development of TKIPs could significantly improve the performance of ALMA and other future radio telescopes. For this reason, the study of TKIPs is considered a strategic investment in NRAO's long-term technology program.

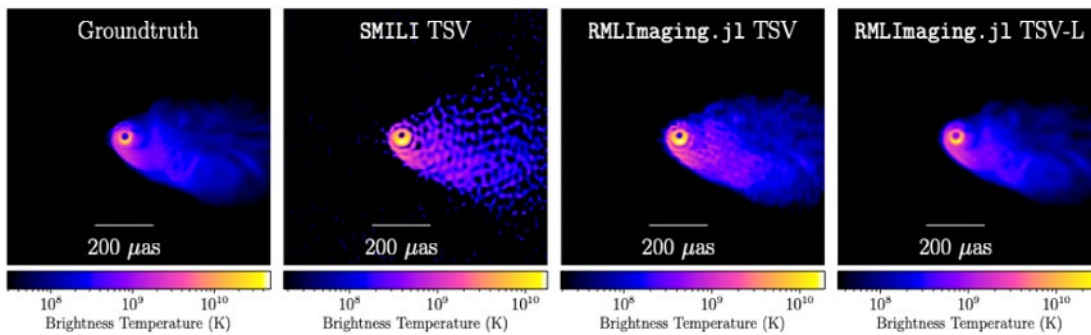

*Example of Regularize Maximum Likelihood (RML) imaging (right-most panel) compared to model image (left-most panel) and other methods from the Study report.*

## Ongoing Development Studies

**2nd Generation ALMA Correlator/Beamformer – Advanced Technology ALMA Correlator (NRC/NRAO):** The Advanced Technology ALMA Correlator (ATAC) is a cornerstone of the WSU initiative to expand the ALMA System bandwidth by a factor of two (expandable to a factor of four in the future) with vastly more spectral channels, and increased sensitivity. This design and construction project is a collaboration between NRC (hardware and firmware) and NRAO (software and integration) and started in Q2 FY2023 after ALMA Board approval in Q1 FY2023. Submission of this proposal to the ALMA Board was a major FY2023 milestone.

**ALMA Band 6v2 Receiver Upgrade – Phase 1 (NRAO):** This project will design and test a production-ready 2nd Generation Band 6 receiver (Band 6v2) for the WSU. Band 6v2 will at least triple the IF bandwidth of ALMA's most used receiver band, significantly improve its noise performance, and provide the ability to simultaneously observe multiple diagnostic spectral lines. This project will culminate in a Critical Design Review (CDR) in FY2025. A Preliminary Design Review is planned for Q4 FY2024 and a follow-on project will be submitted after successful CDR for the manufacturing phase.

**ALMA Phasing System Phase 2 (APP2) (MIT Haystack Observatory):** The APP2 project includes several initiatives to improve ALMA VLBI capabilities and performance. Major components include enabling spectral line VLBI, extending the frequency range of phasing to Bands 1–7, improving the calibration mechanism to allow observations on weaker sources called the “delay-fix.” This project has been delayed by several unavoidable factors including the COVID-19 pandemic, the ALMA cybersecurity attack, and even poor weather during several of the commissioning campaigns. It is on track to finish in Q3 FY2024.

**Enabling New VLBI Science with the ALMA Phasing System – Phase 3 (APP3) (MIT Haystack Observatory):** The APP3 project has significantly improved ALMA's ability for science operations to carryout VLBI/phasing observations in a more automated fashion. After an anticipated No Cost Extension to complete a Broader Impacts informational video, it will complete in Q3 FY2024.

**Characterization of New Helium Compressor for Cryogenic System (NRAO):** This NRAO project aims to test a new Sumitomo Variable Speed compressor used in the ALMA Front End receiver cryostat due to the limitations revealed during extreme cold weather at AOS. Major aspects include classification of the compressor under field conditions, determination of efficient cold temperature start-up and optimum speed versus thermal loading, and estimates of operational power and science time savings. After a No Cost Extension, it is expected to complete in Q1 FY2024

**Band 3 Cold Cartridge Assembly Magnet and Heater Installation (JAO/NRC-Herzberg):** Production deflux heaters will be installed in the Band 3 cold cartridge to reduce the azimuth-dependent total power variations observed in the ALMA antennas. This project has transitioned from production to implementation with JAO taking over execution responsibility.

**Investigate Use of Next Generation FPGA Technology in the Advanced Technology ALMA Correlator (NRC):** Study of the cutting edge Agilex Field Programmable Gate Arrays (FPGA) family for use in ATAC.

**Wideband Isolators for Submillimeter Astronomy (SAO):** Development of a wide IF isolator for potential use in Band 6v2.

**Wideband InP and GaAs Intermediate-Frequency Low Noise Amplifiers (NRC):** Investigation of alternative materials for the improved performance of Low Noise Amplifiers, a critical component of sensitive (sub)millimeter receivers.

**A Detailed Characterization of Spectral Regridding and Noise in the WSU Era (SAO):** Development of improved gridding techniques for better spectral noise performance in image cubes.

The last three of these studies are the result of the FY2023 call for Studies, while the first is a two-year strategic study that began in FY2022 (studies that are of particularly strategic importance and are time-critical). All of these studies will provide important input to the WSU and future ALMA upgrades and are expected to finish in FY2024. Completion of the FY2023 Call for Studies review process and the start of the Study funding were major FY2023 milestones.

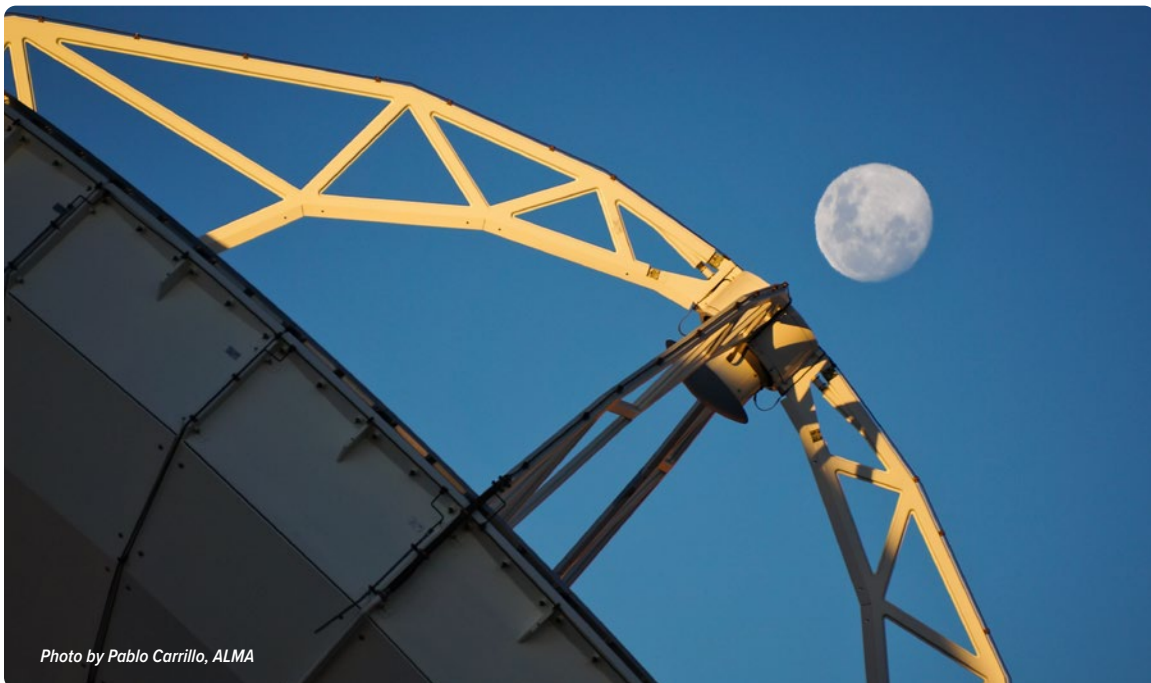

# NEXT GENERATION VERY LARGE ARRAY



*Photo by mtex antenna technology, GmbH*

The NRAO further engaged the science and technical community from 2021-2023 in the design of a next generation Very Large Array (ngVLA), a world class scientific facility consisting of an interferometric array with 10x the sensitivity and 10x higher spatial resolution than the VLA and the Atacama Large Millimeter/submillimeter Array (ALMA). The ngVLA will open a new window on the Universe through ultra-sensitive imaging of thermal line and continuum emission down to milliarcsecond resolution, as well as unprecedented broadband continuum polarimetric imaging of non-thermal processes. These capabilities are required to address a broad range of critical questions in modern astronomy, including: (1) direct imaging of planet formation in the terrestrial zone; (2) studies of dust-obscured star formation, and the cosmic baryon cycle down to parsec-scales out to the Virgo cluster; (3) making a cosmic census of the molecular gas that fuels star formation back to first light and cosmic reionization; and (4) novel techniques for exploring temporal phenomena from milliseconds to years in this multi-messenger astrophysics era. The ngVLA will be optimized for observations at 1.2–50.5 GHz and 70–116 GHz, between ALMA at submillimeter wavelengths and the future Phase I Square Kilometre Array (SKA-1) at decimeter and longer wavelengths.



The Astronomy and Astrophysics Decadal Survey (Astro2020) of the U.S. National Academy of Sciences published its report and the Next Generation Very Large Array (ngVLA) received high priority for new ground-based observatories to be constructed during the coming decade. The report, in which ngVLA shared second ranking among ground-based projects, was the culmination of a lengthy process aimed at developing a comprehensive research strategy and vision for a decade of transformative science at the frontiers of astronomy and astrophysics.

In 2023, the ngVLA project has continued to develop the science requirements, system requirements, system architecture, and supporting system design that form the foundation for prototype development and testing.

### Science Goals

The compelling science case and reference design for the ngVLA were developed via a collaboration between NRAO and the international astronomy community, led by the ngVLA Science Advisory Council. More than 80 broad and compelling science cases were developed at 1.2–50.5 GHz and 70–116 GHz. Each of the derived key scientific goals (KSGs) for a future radio/millimeter telescope must: (1) address an important question in astrophysics that has broad scientific and societal implications; (2) require the capabilities of a ngVLA; (3) exhibit synergies with existing or planned facilities in the 2025+ time frame. The five high-priority ngVLA key science goals are:

- *Unveiling the Formation of Solar System Analogs on Terrestrial Scales*
- *Probing the Initial Conditions for Planetary Systems and Life with Astrochemistry*
- *Characterizing the Assembly, Structure, and Evolution of Galaxies Over Cosmic Time*
- *Using Pulsar in the Galactic Center as Fundamental Tests of Gravity*
- *Understanding the Formation and Evolution of Stellar and Supermassive Black Holes in the Era of Multi-Messenger Astronomy.*

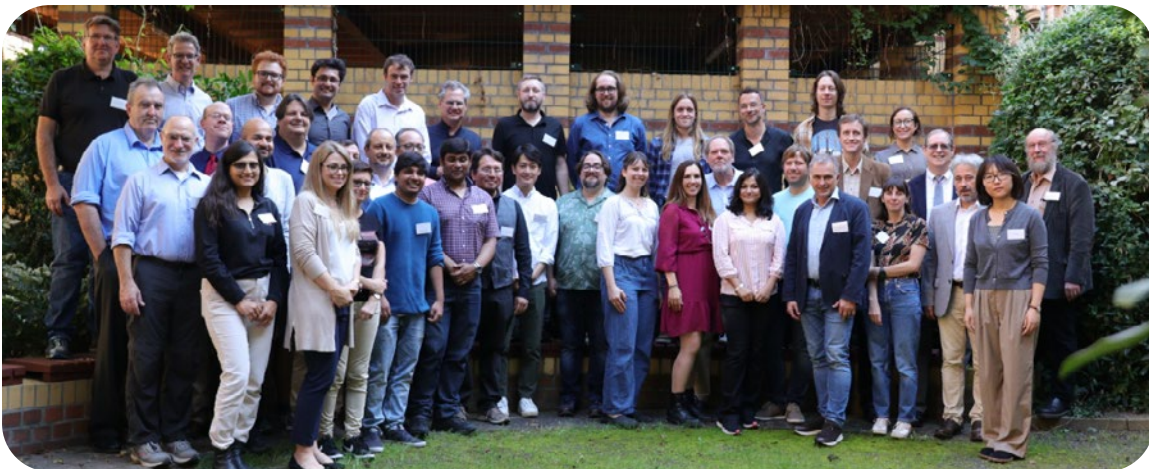

*Above: Second Workshop on German Science Opportunities for the ngVLA, Leipzig, Germany, September 2023*

# NEXT GENERATION VERY LARGE ARRAY

## Technical Concept

The ngVLA technical concept is a synthesis radio telescope operating at centimeter wavelengths that consists of 263 reflectors connected by optical fiber to a signal processing center. Implementation and logistics divide the array into three subsets:

- A Main Array (MA) of 244 reflector antennas each 18m diameter, operating in a phased or interferometric mode, distributed to sample scales from 10s of meters to 1000km. A dense core and spiral arms provide high surface brightness sensitivity, while outer stations increase resolution.
- A Short Baseline Array (SBA) of 19 reflector antennas of 6m aperture will be sensitive to a portion of the larger angular scales poorly sampled by the MA.
- A Long Baseline Array (LBA) of 30 reflector antennas each of 18m diameter located in 10 clusters will provide continental-scale baselines up to ~8860 kilometers and sub-milliarcsecond resolution.

The ngVLA will have ~10x the sensitivity of the VLA and ALMA, continental-scale baselines providing sub-milliarcsecond-resolution, and a dense core on kilometer-scales for high surface brightness sensitivity. The facility will be operated as a proposal-driven instrument. The key deliverable for ngVLA users will be images and image cubes generated using calibration and imaging pipelines. Pipeline products, raw visibilities, and calibration tables will be archived.

## ngVLA Project

In August 2021, the National Science Foundation (NSF) awarded the NRAO \$23 million for the final design and prototype of the selected 18m antenna design.



*Photo by Brian R. Kent, NRAO/AUI/NSF*

The ngVLA Project successfully completed its Technical Conceptual Design Review in July 2022. This verifies that the technical design is likely to meet all the performance driving requirements. This successful milestone set the stage for the Programmatic Conceptual Design Review.

NSF formally entered the ngVLA project into the MREFC process, at the Conceptual Design Phase (CDP), in July 2023. This major step forward for the project reflects the strong concept and scientific promise brought forward, and the great execution we have demonstrated in recent years.

In September 2023, NRAO announced that the National Science Foundation (NSF) awarded a 3-year, \$21 million grant to Associated Universities, Inc. (AUI) to further the design of the next generation Very Large Array (ngVLA).

*mtex antenna technology GmbH* was contracted to design, develop, and produce the 18m ngVLA prototype antenna. The National Radio Astronomy Observatory (NRAO) has selected a contractor to develop a production-ready design and produce a prototype antenna for the Next Generation Very Large Array (ngVLA). NRAO officials signed an agreement with *mtex antenna technology GmbH*. At an Open Day Event in Leipzig, Germany, September 2023, portions of the prototype were unveiled to government and business leaders, scientists, engineers, and the press from Germany and the U.S. The event was preceded by a conference showcasing the interests of the German community in ngVLA science and opportunities.

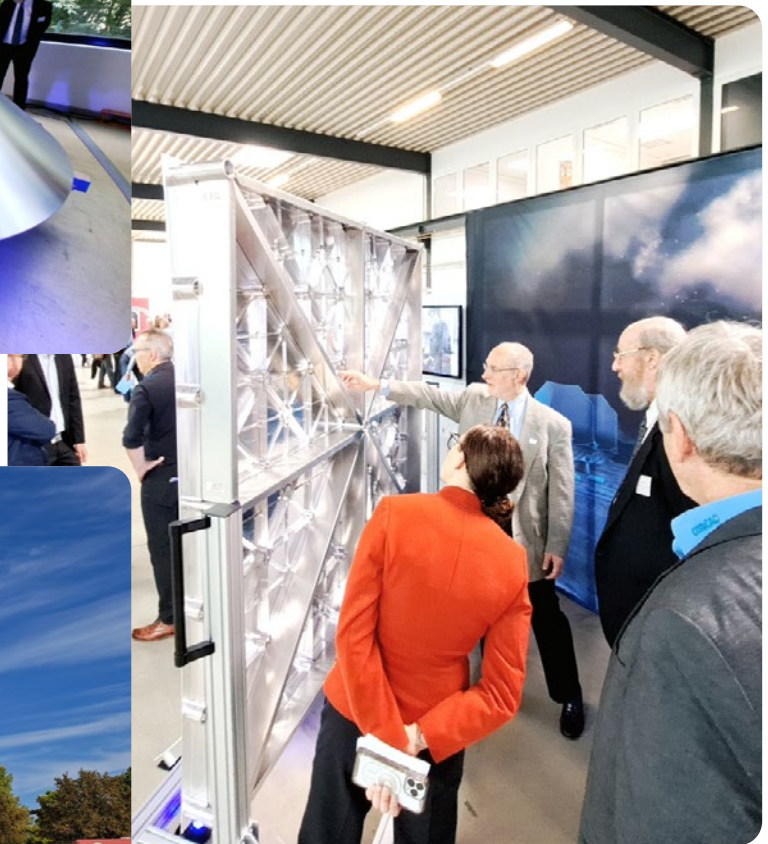

Photos by Brian R. Kent, NRAO/AUI/NSF

# NEXT GENERATION VERY LARGE ARRAY

## Community Engagement

The ngVLA project and community hosted a number of events in partnership with global collaborators, showing the worldwide interest in ngVLA science and engineering.

- New Views of Galaxy Formation and Evolution, Winter AAS Conference, January 2021
- Computational Astrophysics in the ngVLA Era, Flatiron Institute, New York, NY, June 2022
- Chemical Probes of Astrophysical Systems, Winter AAS Conference, Seattle, WA, January 2023
- Transition from VLA/VLBA to an ngVLA, Summer AAS Conference, Albuquerque, NM, June 2023
- New Eyes on the Universe with ngVLA and SKAO, Vancouver, BC, Canada, May 2023
- En Route to the Next Generation Very Large Array with IRyA-UNAM, Morelia, Mexico, September 2023
- Second Workshop on German Science Opportunities for the ngVLA, Leipzig, Germany, September 2023

The ngVLA Project continued to build and refine the conceptual design and science case throughout 2021-2023, driven by the community, coordinated by NRAO, and apropos to NSF Major Research Equipment and Facilities Construction (MREFC) candidacy. Additional science cases identified by the community were incorporated into the ngVLA Science Book. The Project focused on developing the detailed ngVLA conceptual design, working towards an external design review in 2022.



Above: New Eyes on the Universe with ngVLA and SKAO, Vancouver, BC, Canada, May 2023



The ngVLA continues to distribute technical and scientific notices to the community via the online NRAO Newsletter. Five science working groups have also formed, with periodic meetings, chaired by astronomers from the community:

- SWG1: Stars, Planetary Systems, and their Origins  
*Co-Chairs: Brenda Matthews (NRC-Victoria) & David Wilner (Harvard CfA)*
- SWG2: Astrochemistry and the Molecular Emergence of Life  
*Co-Chairs: Brett McGuire (MIT) & Jennifer Bergner (Chicago)*
- SWG3: Galaxies and Galaxy Evolution  
*Co-Chairs: Fabian Walter (MPIA) & Rachel Somerville (Flatiron Institute/CCA)*
- SWG4: Pulsars, Cosmology, and Fundamental Physics  
*Co-Chairs: Megan DeCesar (George Mason) & Alexander van der Horst (George Washington)*
- SWG5: Exploring the Dynamic Universe  
*Co-Chairs: Rachel Osten (STScI) & Alessandra Corsi (TTU)*

[ngvla.nrao.edu](http://ngvla.nrao.edu)



Above: En Route to the Next Generation Very Large Array with IRyA-UNAM, Morelia, Mexico, September 2023

A large radio telescope dish is positioned in a field under a starry night sky. The Milky Way galaxy is visible in the background, stretching across the sky. The dish is illuminated by a warm light source, possibly the setting or rising sun, creating a silhouette effect. The foreground shows a dirt road leading towards the telescope. The overall scene is a mix of natural beauty and scientific technology.

## NEW MEXICO OPERATIONS

The Karl G. Jansky Very Large Array (VLA) and the Very Long Baseline Array (VLBA) are maintained and operated from New Mexico. Both instruments provide unique centimeter-wavelength capabilities to the astronomy community. During 2023, NRAO commissioned new observing modes for these instruments, matched to the latest scientific requirements. The following sections describe the operational, maintenance, and development activities associated with each instrument. Many activities are closely coordinated across the VLA and the VLBA and are carried out by the same personnel.

## Karl G. Jansky Very Large Array (VLA)

The VLA comprises twenty-seven 25-meter diameter antennas in a Y-shaped configuration on the Plains of San Agustin in west-central New Mexico. From 2021-2023, NRAO continued to offer a suite of robust and scientifically powerful observational capabilities designed and tailored to address scientific needs.

### Science Operations

NRAO continued to offer three types of observing programs to VLA users in the Calls for Proposals issued from 2021-2023: General Observing (GO), Shared Risk Observing (SRO), and Resident Shared Risk Observing (RSRO).

In the Call for Proposals for the 2021B observing semester, two capabilities were promoted from SRO to GO: 4-band observing in Stokes I, and dual 4/P bands observing in Stokes I. In the Call for Proposals for the 2022A observing semester, no new GO capabilities were added while the default eLWA (VLA+LWA) observing mode (single 8 MHz subband centered at 76 MHz, and 4-bit VDIF output) was promoted from RSRO to SRO.

For the 2022B and 2023A observing semesters, no new GO or SRO capabilities were added. A little-used, frequency-averaging mode that was causing failures elsewhere in the system was disabled to improve the robustness of General and Shared Risk observing. The online frequency-averaging capability remains available through the RSRO program. Under SRO, several new subarray observing capabilities were added: up to three independent subarrays using standard 3-bit continuum setups, or a mix of standard 3-bit and standard 8-bit continuum setups, and up to three independent subarrays with changing standard continuum setups in a given subarray (e.g., to perform reference pointing at X-band for high frequency observations). RSRO programs supported in FY2022 included fast-dump times, data rates above 100 MB/s, 4-band polarization, 4-band spectral line, 4-band coherent-dedispersion ("Y" Ultimate Pulsar Processing Instrument or YUPPI) pulsar observing, eLWA observations and correlations using options other than the one offered under SRO, subarray observations with setups other than the default continuum setups, or observations with more than three subarrays, and rapid response capability. In 2023, science observing for both the Jansky Very Large Array Sky Survey (VLASS) and extra-large proposals continued.

A large fraction of the 2021-2023 scientific support went toward maintaining receiver, antenna, and array performance and ensuring that the NRAO user community had access to quality instrumentation and updated information to effectively use the VLA. Operational tasks carried out by the scientific staff in support of these functions are listed below.

Technical documentation detailing hardware and software functionality for staff and users was written, as well as operational procedures and documentation for the operations staff. The VLA Observational Status Summary was updated before the 2021B-2023B Call for Proposals, along with the Guide to Proposing with the VLA and the Guide to Observing with the VLA on the NRAO science web site.

The sensitivity and gain response of each antenna at each band was characterized periodically. Surface accuracy checks with holography were carried out to ensure optimal efficiency at the highest frequency bands. Antenna positions, collimation offsets, and pointing accuracy were determined whenever the array was moved into a new configuration.

Antenna positions, collimation offsets, and pointing accuracy were determined each time an antenna came out of the Antenna Assembly Building after a maintenance overhaul. The performance of the new Antenna Control Units (ACUs) was evaluated.

## NEW MEXICO OPERATIONS

Health checks were performed to determine if there were any hardware failures that must be followed up with maintenance tickets. Radio Frequency Interference (RFI) monitoring tests were carried out to characterize and help mitigate RFI contamination in observing bands.

Data quality was evaluated based on pipeline results, and test observations were run to identify and diagnose problems that were not caught by the standardized tests and engineering checks. Detailed data was collected with the array for a range of calibration purposes, including flux density scale calibrator models, and polarization and bandpass calibration.

### Array Operations

Array reconfigurations were completed as follows:

- FY2021 comprised the moves into the BnA configuration to support the VLA Sky Survey (southern sky, epoch 2.1), followed by the A, D, C, and B configurations.
- FY2022 comprised the moves into the BnA configuration to support the VLA Sky Survey (southern sky, epoch 2.2) followed by the A, D, and C configurations.
- FY2023 comprised the moves into the C and B configurations, the BnA configuration to support the VLA Sky Survey (epoch 3.1), followed by A configuration.

In 2022, the VLA Operators were trained on how to address the system health of the commensal VLA Low Band Ionospheric and Transient Experiment (VLITE) P-band observing system. The VLA Operators documented and were trained on how to troubleshoot and resync the Digital Transmission System's (DTS) digitizers, and developed instructions for resetting the Correlator Back End (CBE).

In 2023, one of the VLA Operators was cross-trained to operate the VLBA and assist with the shift schedule. The Array Operations Division also worked closely with the EHS Division to write new, and update existing, safety manuals and protocols, and to determine the required and recommended safety training programs the NM Array Operations staff should take. The VLA thunderstorm monitoring system was moved to the Vaisala Thunderstorm Manager, replacing an in-house system that was no longer reliable.



### Development

**Wideband Interferometric Digital Architecture (WIDAR) Real-time RFI blanking:** Between FY2019 and FY2022, the ability to blank data at high time resolution in the WIDAR correlator as a mechanism for excising RFI was demonstrated and developed. During FY2023, this capability was offered to observers under RSRO, while in Q4, the evaluation that was conducted by the scientific staff concluded its readiness for general science observations on the array. Consequently, this capability was enabled in the NRAO default (continuum) setups for L through Ku-band. For all other use cases (e.g., non-default continuum, spectral line, and pulsar setups) observers will have the ability to opt-in via a toggle in the OPT. These new RFI-blanking-enabled default setups, as well as the toggle to apply WIDAR RFI blanking in all other setups, were made available in the OPT release 1.32.00 (Q4).

**Commensal Open-Source Multimode Interferometer Cluster Search for Extraterrestrial Intelligence (COSMIC SETI):** The NRAO and the SETI Institute have entered into a collaborative agreement to enable SETI using the VLA. A new system has been developed that will allow for state-of-the-art commensal, real-time SETI analysis to happen in parallel with all standard VLA observations. This system receives digitized data (pre-correlation) from each VLA antenna via optical fiber, and distributes the data via ethernet to a compute cluster capable of real-time software correlation and beamforming. Nearby target stars within the VLA field of view will be searched for drifting narrowband (~Hz-bandwidth) signals indicative of advanced technology. The desire is to operate the system during the third epoch of observing for the VLA Sky Survey, during which ~40 million stars will be searched for technosignatures.

A design review for the COSMIC system was held in FY2022, the results of which determined the scope and scheduling for infrastructure improvements in the West Chamber of the Control Building at the VLA site, where the COSMIC equipment is located. The plan is for COSMIC-SETI to become operational as a commensal system on the VLA during FY2023, collecting data during unconflicted PI science observations (including VLASS). The Observatory has implemented a software switch, which will be exposed to the PIs via the OPT when COSMIC is operational, and with which PIs may choose to opt out of allowing COSMIC to run commensally during their observations. The COSMIC system is funded by the SETI Institute, with the construction effort extending through FY2023.



*Above: The Commensal Open-Source Multimode Interferometer Cluster Search for Extraterrestrial Intelligence (COSMIC SETI) system backend at the VLA site.*

## Electronics Maintenance and Renewal

The New Mexico Electronics Division maintains all VLA electronic components, VLA servo and fiber systems, and the Wideband Interferometric Digital Architecture (WIDAR) Correlator. Division staff are located either at the VLA site or at the DSOC in Socorro, with maintenance and renewal activities occurring at both places. Due to the lifecycle stage of the VLA, maintenance and obsolescence management is a critical focus for the Division.

### **Digital:**

- Replaced aging WIDAR power system components.
- Performed checks on the WIDAR Correlator boards and replaced or repaired as needed.

### **Front End and Cryogenics:**

- Overhauled approximately 30 receiver cold heads per quarter to keep VLA receivers operating.
- Reconditioned and replaced receiver desiccant in each of 240 units twice during the year.
- Performed preventive maintenance on 25 VLA compressor lines twice during the year.
- Overhauled two VLA compressors due to normal wear-and-tear.
- Performed preventive maintenance on four helium circuits to maintain cryogenic performance.
- Repaired approximately 25 Front End receivers during the year.
- Repaired and/or upgraded more than 20 Front End M&C modules during the year.
- Ongoing repair of the Low Band Receiver system.

### **Local Oscillator and Intermediate Frequency (LO/IF):**

- Investigated issues with locking, fringing, output power, and general communication dropouts.
- Performed routine power supply and battery maintenance, including replacement of units.
- Repaired or replaced approximately 20 RF Switches (Band Switches).

### **Servo and Fiber:**

- Performed checks of the fiber optics system to ensure proper operations; applied resets as needed.
- Bearing change support.
- Performed maintenance on legacy ACUs and Focus Rotation Mount (FRM) controllers.
- Installed new ACUs in two antennas, in addition to one that was started in FY2022 and carried over to FY2023.

### **Multiple Groups and Systems:**

- Retrofitted upgrades or additions to enhance equipment safety.
- Performed bench work on modules for repair or assembly.
- Monitored modules responsible for array timing and transmission of data and adjusted as needed.
- Identified several new sources of RFI, particularly in L, S, and C bands.

## Site Maintenance and Renewal

The Engineering Services Division is responsible for nearly all of the maintenance and renewal activities performed on the VLA site facilities, antennas, and rail system.

**Antennas:** An azimuth bearing change on antenna 20 was completed in early FY2023. VLA antennas were routinely cycled through the AAB for checkout and overhaul throughout the year. The original plan was to overhaul five antennas. Only four antennas were overhauled during FY2023 because the year's first overhaul took longer than planned, following a bearing change and subsequent troubleshooting of its servo system. Other overhaul delays were caused by the Focus Rotation Mount smart motor supply chain delays and an extended calibration problem with an elevation encoder.

The two transporters used to move the antennas during reconfigurations underwent planned maintenance and repair between move periods. Maintenance on the more-than-40-year-old transporters included servicing the motors, checking the generators that maintain critical power to the antenna during a move, lubricating the moving parts, checking on the total of 24 axles and wheels, and maintaining electrical and hydraulic systems.

**Track:** During FY2023, inspection of the VLA railroad tracks continued, checking for problems that could compromise the safety of the transporters that carry the antennas during array reconfigurations and other antenna moves. These inspections also guarded against problems that could jeopardize the safety of the maintenance rail vehicles that are used by technicians to service the antennas.

A total of 5,123 cross-ties were replaced in FY2023, exceeding the preventive maintenance program’s target goal of 5000 ties for the year. Five track intersections/spurs were replaced in FY2023, also per plan.

**Site Infrastructure:** VLA site buildings, utility systems, and grounds continued to undergo routine annual inspection and preventive maintenance in FY2023. The 3 MW site backup generator was load tested and several generator and switchgear parameters were changed as a result of the recent engineering consultants’ recommendations. These changes resulted in greater system stability and improved the system’s response to minor power grid perturbations. This has greatly reduced the interruptions to observational readiness. Other regular activities included: annual road grading; general roof repairs; heating and cooling systems maintenance; pest and weed control along the railways and central site; fire brigade and emergency medical response team training; and the routine servicing of gas pumps, sewer, and water supply systems. Backup generator power, along with other related systems, also underwent preventive maintenance.



# NEW MEXICO OPERATIONS

## Observing Capability Enhancements

The VLA continued to provide new capabilities to the user community to optimize and enhance the science that can be done with the array. This strategy has proven to be effective in keeping users engaged, and it is a critical factor in keeping the scientific productivity of the VLA high. Scientific staff and RSRO efforts were directed to the following observing capability enhancements in FY2021-2023

**4-band and 4/P Stokes I Continuum Observations:** The 4-band Stokes I and the dual 4/P-band Stokes I continuum observations were promoted from SRO to GO in the 2021B Call for Proposals. The proposing and observing tools were updated accordingly.

**Expanded Long Wavelength Array (eLWA):** In FY2021, the eLWA was added to the NRAO Proposal Submission Tool, and the generation of dynamic eLWA observing schedules has been added to the VLA observing software. As a result, eLWA observing with default settings (8 MHz bandwidth centered at 76 MHz with 4-bit VDIF output) was promoted to SRO in the 2022A Call for Proposals. Relevant user documentation was also updated to reflect this capability.

**Wideband VLA for VLBI:** The phased VLA (Y27) is often used as a single element in VLBI experiments. In addition to the summed array signal for VLBI, VLA imaging data (visibilities) are always obtained in parallel via the WIDAR correlator and can be useful for many experiments. During these observations, the bandwidth has in the past been limited by the VLBI recording capability to a maximum of 512 MHz (4096 Mbps), far less than the bandwidth that can be delivered by the VLA's WIDAR correlator, which can be up to 2 GHz with the 8-bit samplers and up to 8 GHz with the 3-bit samplers. When configured properly, WIDAR can provide wide-band visibility data during these experiments, resulting in a significant increase in the sensitivity of the VLA-only imaging data. In FY2023, this capability was further developed and the relevant software components validated in order to deliver VLA data from the WIDAR correlator with the full bandwidth of the 8-bit samplers (2 GHz). This capability was offered under SRO in the VLBA portion of the 2024A Call for Proposals

## Technical Upgrades and Enhancements

**VLA ACU Replacement:** The electronics components to repair the existing VLA ACUs are no longer available. Without replacement parts, antennas with failed ACUs would no longer be able to participate in observations, posing a serious operational risk. All of the legacy VLA ACUs must be replaced with newer technology units to increase the operational lifetime of the VLA antennas, as well as eliminating some inherent problems with the legacy design and greatly improving the pointing and tracking capabilities of the antennas. The first new ACU was installed in FY2013. Three additional ACUs were installed in FY2023 (one of these was carried over from FY2022, as noted above), leaving six antennas still using the legacy system.

**Variable Frequency Drive (VFD) Development:** A modest amount of additional characterization and optimization of the Variable Frequency Drive (VFD) took place in FY2022 in anticipation of possible future deployment on the green antenna. The combination of the Buffered Compressor Tank and the VFD reduces power consumption while extending the operational time of cryogenic system components.

**Buffered Compressor Tank Development:** The system installed on antenna 14 was monitored during FY2023. It continued to perform as expected, but there were insufficient resources to deploy the design on a second antenna.

**Emergency Notification System:** The NRAO continued to use the Rave Alert system for emergency notifications in New Mexico during FY2023. Approved use of this system at the start of the fiscal year included any event that triggers Emergency Operations Status (EOS), including, but not limited to, inclement weather, network/power outages, evacuations, national and state alerts, and tests/training. Later in the year, changes to FCC regulations around the use of emergency notification systems required modifications of its use and operation. NM Operations assessed the system under these conditions during FY2023 and determined that Rave remains useful for emergency communications in NM.





*Photo by Brian R. Kent, NRAO/AUI/NSF*

## Very Long Baseline Array (VLBA)

The VLBA comprises ten 25-meter diameter antennas at locations extended from Hawaii to the U.S. Virgin Islands. This facility is the highest resolution dedicated ground-based astronomical instrument in use by the worldwide scientific community.

### Science Operations

The NRAO continued to offer three types of observing programs to VLBA users in FY2023: General Observing (GO), Shared Risk Observing (SRO), and Resident Shared Risk Observing (RSRO). As for the VLA, any VLBA observing mode that does not fall under GO or SRO may be proposed under the RSRO program. In the Call for Proposals for both 2021B through 2023B observing semesters, no new GO or SRO capabilities were offered. RSRO programs supported in FY2021 included many pulse cal tones per channel, improved troposphere model, rapid response capability, L/P dual-band observations, Y3 observing with the VLBA, and recording wide-band VLA visibilities in parallel with Y27 VLBI. In the Call for Proposals for the 2024A observing semester, no new GO capabilities were added, while under SRO the delivery of wideband VLA data (from WIDAR) during VLBI observations was offered.

Operational tasks carried out by the scientific staff during FY2021-2023 in support of maintaining receiver, antenna, and array performance and ensuring that the user community had access to quality instrumentation and updated information to effectively use the VLBA are listed below.

Capabilities to be offered from the 2021B through the 2024A semesters were defined, and user documentation for all capabilities for the relevant Call for Proposals updated; scientific testing of user tools needed to prepare proposals (e.g., Proposal Submission Tool (PST), European VLBI Network Sensitivity Calculator and Observation Planner) was undertaken, and technical reviews for proposals and evaluation of proposals for RSRO contributions were performed. As for the VLA, the technical review process for the VLBA proposals was also revised in the 2024A semester.

Technical documentation detailing hardware and software functionality for staff and users was written, as well as operational procedures and documentation for the operations staff. The VLBA Observational Status Summary was updated before the 2023B and 2024A Calls for Proposals, along with the Guide to Proposing with the VLBA and the Guide to Observing with the VLBA on the NRAO science web site. In FY2022, the VLBA observation preparation software (SCHED) version 11.7 and associated user documentation were released to incorporate various enhancements and bug fixes. Scientific testing and validation of SCHED 11.7 were carried out before the release. The new, next generation Python-based VLBA calibrator search tool was also released in FY2022 after extensive testing and scientific validation. This replaced the legacy VLBA calibrator search tool. New user documentation has also been posted online.

**User Support:** VLBA User Support continued to be provided by scientific staff in NM Operations on all aspects of proposing, observing, data access, and data reduction via the helpdesk and/or one-on-one when applicable.

**Track and Measure VLBA Sensitivity, Pointing, and Focus:** The sensitivity, pointing and focus of each antenna at each band were characterized periodically, as receivers and equipment were replaced or as software was upgraded. During FY2022, real-time interferometric pointing developed in FY2021 became the standard method for determining and maintaining VLBA antenna pointing models. In FY2022, VLBA staff also defined the software requirements for the use of real-time interferometry for reference pointing with the long-term goal of improving the high-frequency performance and capabilities.

**Clock Maintenance:** Accurate time keeping is central to VLBI, and is provided by hydrogen masers and reference signals inserted into the astronomical data. Quality assurance checks were performed periodically by scientific staff and data analysts.



*Photo by Jeff Hellerman, NRAO/AUI/NSF*

# NEW MEXICO OPERATIONS

**System Health and Maintenance Feedback:** Routine health checks and analysis of the data to determine if there are any hardware failures were followed up with maintenance tickets. RFI monitoring tests were carried out to characterize and help mitigate RFI contamination in observing bands.

**Data Quality Assurance Checks:** Data quality was evaluated and test observations run to identify and diagnose problems that were not caught by engineering checks.

**Coordination for Global Millimetre VLBI Array and the High Sensitivity Array (I):** The VLBA occasionally observed in parallel with other observatories, as requested by users whose scientific goals require the inclusion of baselines to large aperture and/or distant facilities. Scheduling and correlation of these observations required coordination with local schedulers at each participating observatory, a significantly more complex process than normal VLBA-only observations require.

## Array Operations

Standard scheduling and observing procedures were used during FY2021-2023 for the VLBA. The VLBA operations staff also correlated and inspected observations using standard methods.

VLBA Operations is moving towards the ability to perform electronic transfer of incoming data from non-VLBA stations over the internet, in particular, to minimize the need for the shipping of disk packs internationally. During Q3 and Q4 of FY2023, the Phase 1 VLBA E-transfer Operations Plan document was drafted (and will be finalized in Q1 FY2024). The equipment required to conduct electronic transfer was also procured and delivered to the DSOC.

Every day, the USNO used two to five VLBA antennas to perform Earth orientation measurements. After observations were completed, a data quality assessment was performed by VLBA Operators and then the data were made available for download to the USNO correlator. When needed, the VLBA correlator was used as a back-up to the USNO correlator. This capability was tested on a two-station observation every month. In these tests, data from Kōke'e Park, Hawaii, and Wettzell, Germany were transferred to the VLBA correlator and then the data were correlated and post-processed on computers within the DSOC.



## Development

During FY2021-2023, progress was made on a number of development projects.

**VLBA Back-End Retrofit Project (VBER):** After being delayed by the Contreras fire, the final E-Rack was installed at Kitt Peak. Production of the P401 Power Supplies was completed and sufficient network switches and other material procured to outfit the entire VLBA. E-Racks were fully commissioned at Owens Valley and Pie Town and commissioning was nearly completed at Brewster by the end of the fiscal year. A Preliminary Design Review (PDR) of the proposed Timing and Reference Distribution (TRD) solution was completed and the selected commercial equipment passed both lab testing and RFI screening.

**VLBA New Digital Architecture Project (VNDA):** The VNDA team changed its approach in FY2023 due to the difficulties encountered in FPGA programming. The VNDA project has two major modules under development: the Producer, which samples data and formats onto Ethernet, and the Consumer, which channelizes and requantizes the data. The overall functionality of these modules has not changed, but the development

methodology has been modified. In the case of the Producer, FPGA code will be developed by an external contractor. For the Consumer, a separate external vendor will be developing software on Graphical Processor Units (GPUs). Contracts for the two external vendors were established late in FY2023. Detailed planning for acceptance of the externally produced firmware/software were developed. Plans for initial laboratory testing were updated to reflect the project change.

**VLBA ACU Design Development:** The effort to develop a replacement for the obsolete VLBA ACU and other drive system components was initiated with a two-day kick-off meeting in Q4 FY2023. Completion of the ACU conceptual design is anticipated in FY2024, along with some minimal purchases of items needed for evaluation.

**CSA-F (High-speed VLBA networks):** CSA-F funded operation of the high-speed VLBA fiber network links. The remaining budget was evaluated and a plan for spend-down was completed. Remaining funds were sufficient to allow an increased level of service at Saint Croix (increase from 200 to 600 Mbps). Effort continued to further develop capabilities enabled by high-speed fiber. This included the ability to transfer in real-time a subset of data when observing using the Polyphase Filter-Bank (PFB) mode. The available data rates limit the use of the high-speed fiber to testing and diagnostic observations, but enable faster response to system problems. Detailed plans for rolling out user-driven real-time correlation were developed. The fiber connection at Mauna Kea was changed from a Hawaii Telco circuit to the University of Hawaii circuit. This change both reduced monthly costs and increased level of service from 1000 to 10000 Mbps.

**E-transfer Filesystem:** Funding was released to embark on developing the VLBA e-transfer filesystem. This system will facilitate electronic transfer of data from foreign antennas and transfer of data to external correlator centers. During FY2023, all of the equipment was procured. Initial operations and software design documentation were developed.

**Real-Time Correlation:** Significant progress was made toward the goal of routine real-time correlation of the VLBA. All VLBA antennas are connected to the internet at speeds no less than 200 Mbps, with identified paths to 10 Gbps at most sites. For reference, the VLBA's current maximum data rate is 4 Gbps, but that will double (or more) over the next few years when VNDA is completed. Using the current network configuration, full array real-time correlation is possible at data rates up to 128 Mbps, corresponding to 32 MHz of bandwidth. In Q2 FY2021, VLBA operations started making use of this capability on a weekly basis after completion of maintenance to verify proper operation of all receivers and the data acquisition systems at all VLBA sites. Plans have also been developed to improve the connectivity of the VLBA correlator to the internet—a necessary update to allow real-time correlation at higher data rates.

## VLBA Maintenance and Renewal

The New Mexico Electronics Division is responsible for maintaining all VLBA electronic components, many mechanical systems, VLBA station infrastructure, and recording and playback hardware. Two VLBA site technicians are located at each VLBA site, and many engineers and technicians provide VLBA support from the DSOC in Socorro.

The site technicians carried out the bulk of the routine maintenance tasks at the VLBA sites. For FY2021-2023 this work consisted of the following:

- Inspection and lubrication of Focus Rotation Mounts (FRM), Azimuth/Elevation drive motors, encoder and pintle bearings, elevation gears, elevation hoist, and changing gearbox oil.
- Check/test encoder motor tachometers, servo limits, ACU, vacuum pumps, all heating, ventilation, and air conditioning (HVAC) systems, dry air system, weather station equipment.
- Perform maintenance on ACUs and FRM controllers.

## NEW MEXICO OPERATIONS

- Ensure safety equipment such as UPSs and generators, emergency power, fire alarm systems, fire extinguishers, and security systems are operating normally.
- Ensure all other preventive maintenance tasks are completed, such as check and replace motor brushes and commutators, check of Azimuth wheel position, check for metal in grease samples, perform cable wrap maintenance, and replace oil filters.
- Repair some VLBA specific modules and electronic systems to relieve some of this task from the technical staff at the DSOC and the VLA sites.
- Maintain the grounds and building infrastructure.
- Other diagnostic and repair tasks as needed.
- Support major maintenance visits to two VLBA sites.

Electronics Division staff based at the DSOC or the VLA performed the following routine VLBA work in FY2021-2023:

### Front End and Cryogenics:

- Overhaul ~60 receiver cold heads to keep VLBA Front Ends operating.
- Perform preventive maintenance on four helium circuits to maintain cryogenic performance.
- Repair and/or upgrade/retrofit eight VLBA FE receivers, on average.

### Local Oscillator and Intermediate Frequency (LO/IF):

- Investigate issues with locking, fringing, output power, and general communication dropouts.
- Monitor maser performance and timing, adjusting as needed.

### Data Acquisition:

- Repair of ~10 VLBA recording and playback modules.
- Repair of up to 50 recording disk packs.



*Photo by Jeff Hellerman, NRAO/AUI/NSF*

### **Multiple Groups and Systems:**

- Retrofit upgrades or additions to enhance equipment safety.
- Perform bench work on modules for repair or assembly.
- Monitor for local RFI at the VLBA sites.
- Send calibrated site weather station hardware to each site as needed.
- Support major maintenance visits to two VLBA sites.

**Major Antenna and Site Maintenance:** Scheduled major maintenance was conducted at both the Mauna Kea and Brewster VLBA sites. During these maintenance visits the following work was conducted:

- Inspect and lubricate Focus Rotation Mount (FRM), azimuth wheel, elevation, and pintle bearings.
- Inspect azimuth and elevation gearboxes and elevation gear sector.
- Inspect feeds, feed cone and dichroic reflector system and replace/repair as needed.
- Inspect and repair azimuth rail and grout.
- Inspect and repair cable wrap and pintle structure.
- Several dish panels on the Mauna Kea antenna were damaged from large blocks of falling ice that had accumulated on legs and FRM during a major ice storm. These panels were repaired during the maintenance visit.

**Owens Valley (OV) Elevation Bearing:** During the FY2022 major maintenance visit to the Owens Valley VLBA antenna, one of the elevation bearings was showing signs of impending failure. A maintenance team was scheduled to replace this bearing in July 2023. The bearing failed at the end of May and the repair was rescheduled and completed in June 2023.

**Engineering Inspection Visits:** The VLBA antennas have been in operation for over 30 years. Senior mechanical and electronic engineers conducted inspections at the Fort Davis, St Croix, and Kitt Peak VLBA antenna sites. These engineers were specifically looking for signs of impending failures due to metal fatigue, age, and corrosion. The engineers inspected the entire antenna structure, mechanical and electronic components on the antenna and in the station building. The results from this inspection are being used to focus future preventive maintenance goals to prolong the antenna life and prevent unscheduled down time.

**VLBA Reliability Analysis:** Due to the age of the VLBA, the failure rate of components and systems has been expected to increase. In fact, the number of maintenance issues has risen over recent years, with a noticeable increase in the failure rate of certain subsystems such as the ACU and motors. To further understand the issue, a reliability analysis effort was planned for FY2023 to ascertain the detailed reliability of at least one electronics subsystem on the VLBA antenna. The milestone was cancelled due to the loss of the engineer assigned to this task and the reassignment of the position outside of the engineering divisions.

**Hancock (HN) Elevation Bearings:** Another major maintenance visit occurred in May at the Hancock VLBA site in order to replace the antenna's elevation bearings. These had been showing signs of nearing end of life, as evidenced by grease inspections. They turned out to be noticeably damaged. The elevation bearing change process is quite complicated since support structures have to be built and installed to take the weight off of the bearings. This work required careful coordination between both engineering divisions and also included an overhaul of the cryogenics system.

**Kitt Peak Return to Service:** The 2022 Contreras fire and its aftermath caused significant damage to Kitt Peak infrastructure, including disruption of the usage of the road and destruction of power and communication lines. New Mexico staff spent over six months remediating minor fire and smoke damage to the VLBA site and solving onsite issues necessary to re-energize and renew communications before observations could begin in February.

### Observing Capability, Technical Upgrades, and Enhancements

The VLBA continued to provide new capabilities to the user community to optimize and enhance the science that can be done with the array. This strategy has proven to be effective in keeping users engaged, and it is a critical factor in keeping the scientific productivity of the VLBA high. Scientific staff and RSRO effort were directed to the following observing capability enhancements in FY2021-2023:

**Wideband VLA for VLBI:** During phased VLA observations, the bandwidth is currently limited by the VLBI recording capability to a maximum of 512 MHz (4096 Mbps), far less than the bandwidth that can be delivered by the VLA's WIDAR correlator, which can be up to 8 GHz. In parallel to developing the requirements for the VLA Observation Preparation Tool (OPT), in FY2022 NRAO developed the software requirements for the VLBA's observing software that will allow telescope users to enable this mode and take advantage of the increase in bandwidth. Specifically, these requirements pertain to the software code vex2opt which reads files produced by the VLBA observation preparation software tool (SCHED) to produce the necessary files that the OPT and its Resource Catalog Tool (RCT) need in order to support wideband VLA observations in VLBI sessions.

**Site Weather Station Upgrades:** The initial design deployed at Los Alamos in FY2021 was refined to improve manufacturability and resiliency against lightning strikes. Material, sufficient to complete installation and commissioning at all VLBA sites, was procured. Full fabrication and assembly of two units was nearing completion at the end of the fiscal year. The goal of completing installation at one VLBA site was not met but completion is anticipated at the beginning of FY2024. It is anticipated that Weather Station production will complete in FY2024 and all sites will be commissioned by the end of FY2025.

**Production and Installation of New L404 Synthesizer Modules:** Production of the new L404 Synthesizers was completed in FY2021 with the exception of some spare units requiring additional RF components to complete the build. Enough modules are now ready for use at all antennas.

**Spectrum Analyzer Purchase:** Six spectrum analyzers were procured in FY2021 for the analysis and repair of VLBA equipment. These will be used to improve the diagnostic capabilities for VLBA sites.

**Site Uninterruptable Power Supply Upgrades:** VLBA site UPS systems have undergone a rolling upgrade cycle in order to standardize and improve the original systems. In FY2022, sufficient material was procured to upgrade two UPS systems.

**Antenna Gearbox Replacements:** During the VLBA engineering inspections, several VLBA gearboxes were disassembled and the internal components were inspected for excessive wear. There were multiple internal gears and bearings that will need replacement in the near future. Attempts to procure these components from the original gearbox manufacturer proved unsuccessful. A gear manufacturer was contracted to fabricate the precision-machined gears and associated parts. The new parts will be delivered in FY2024 and will be installed during future major maintenance visits.





Photo by Jeff Hellerman, NRAO/AUI/NSF

## SCIENCE SUPPORT & RESEARCH



*Galaxy NGC 3351. Credit: ALMA (ESO/NAOJ/NRAO)/ESA/NASA/PHANGS, S. Dagnello (NRAO)*

The NRAO Science Support and Research (SSR) department coordinates and manages the efforts to support scientific users of NRAO facilities, seeks to share the Observatory's science through education and visitor programs for scientists, and supports and oversees the research and scientific productivity of the scientific staff. The efforts of SSR enable the astronomical community to maximize the potential of the world class astronomical facilities afforded by the NRAO.

Telescope Time Allocation (TTA) manages the process and tools by which users prepare and submit proposals for use of the VLA, the VLBA, and the GBT. TTA also manages the proposal evaluation and time allocation process. Science Ready Data Products (SRDP) is a new initiative that is facilitating the use of NRAO telescopes by a growing scientific community that extends beyond the radio astronomy domain experts. Scientific User Support (SUS) provides the scientific community with the support necessary to execute successful scientific programs with NRAO facilities.

The NRAO has a world-class staff of over 100 astronomers, computer scientists, and research engineers, recognized internationally for their excellence in telescope design and support, as well as their technical and scientific knowledge and leadership. SSR supports and oversees the research activities of the NRAO scientific staff, related performance reviews, professional development activities, the Jansky Fellowship postdoctoral program, undergraduate and graduate student programs, and other scientific activities, such as the Jansky Lectureship, scientific meetings, colloquia, and seminars. SSR also manages Observatory-wide reference services, including the NRAO Library, the Historical Archives, and Statistics and Metrics.

## Jansky Fellows 2021-2023

The NRAO Jansky Fellowship program provides outstanding opportunities for research in astronomy. Jansky Fellows formulate and carry out investigations either independently or in collaboration with others within the wide framework of interests of the Observatory. Multi-wavelength projects, computational studies, and theoretical work leading to a synergy with NRAO instruments are encouraged. Nine new Jansky Fellows joined NRAO in 2021-2023. The Jansky Fellows and NRAO Postdocs meet every spring and host the Postdoctoral Symposium, where science and research are shared among their peer group and science and engineering staff.



**Julia Blue Bird** (NRAO/Socorro) completed her Ph.D. in 2021 at Columbia University working with Jacqueline van Gorkom. Julia's PhD thesis research is focused on galaxy evolution with respect to large-scale structure across cosmic time. A main focus of Julia's thesis research involves interpretation of the COSMOS HI Large Extragalactic Survey (CHILES) measurements. Julia intends to continue her research with the CHILES measurements through a number of studies, including a characterization of the gas/star mass fraction as a function of redshift. Julia also has a strong commitment to education and public outreach. As a member of the Oglála Sioux Tribe of South Dakota, Julia intends to reach out to the Native American communities in New Mexico during her Jansky Fellowship with a goal to advance STEM education and understanding within those communities.

**Michael Rugel** (CfA & NRAO/Socorro) investigates the multiphase interstellar medium (ISM) with surveys of the Milky Way at radio wavelengths. His research focuses on the formation of molecular clouds, as well on feedback on them with studies of tracers of atomic, molecular and ionized gas. As a Jansky Fellow at the Center for Astrophysics | Harvard & Smithsonian and at NRAO Socorro, Rugel will expand his research on star formation, and structure and evolution of the ISM with the THOR-GC survey, an extension of The HI, OH, Recombination Line survey of the Milky Way (THOR) to the Galactic center, and the Bar and Spiral Structure Legacy survey (BeSSeL) extension to the southern Milky Way.

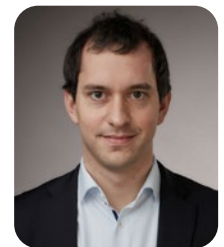

**Dillon Dong** (NRAO/Socorro) completed his Ph.D. in 2022 at Caltech with Gregg Hallinan. Dillon is broadly interested in astronomical objects that evolve over human timescales, and how they interact with their local and large-scale surroundings. He uses a combination of multi-wavelength observations and order-of-magnitude theory to characterize variable and transient sources that he identified in the VLA Sky Survey (VLASS). His current projects involve using supernovae as probes of pre-explosion eruptive mass loss, statistical characterization of black hole and stellar flares, and identifying radio transients with unusual spectral properties. As a Jansky Fellow at NRAO in Socorro, he will continue his study of VLASS transients and variables, with a focus on luminous, extragalactic radio transients. He also will continue his development of flexible tools to automate the detection of transients and variables in future VLA observations.

## SCIENCE SUPPORT AND RESEARCH



**Tao-Chung Ching** (NRAO/Socorro) earned his Ph.D. study at the National Tsing-Hua University, Taiwan, and CfA under the supervision of Shih-Ping Lai and Qizhou Zhang. He later became a FAST (Five-hundred-meter Aperture Spherical radio Telescope) fellow at the National Astronomical Observatory of China working with Di Li. His research interests are interstellar magnetic fields and star formation studied through observational astronomy from submillimeter to radio wavelengths. Using FAST, Tao-Chung has obtained the first Zeeman-effect detection of the HI Narrow Self-Absorption (HINSA) feature. As a Jansky Fellow at NRAO in Socorro, he will use the VLA to explore HINSA as a systematic Zeeman probe, measuring magnetic field strengths of star-forming regions at high angular resolutions.

**Rebecca Charbonneau** (NRAO/Charlottesville) earned her Ph.D. in History and Philosophy of Science from the University of Cambridge in 2021. Her dissertation focused on the history of radio astronomy and examined the challenges and benefits of international scientific collaboration during the Cold War period. She subsequently worked as the historian-in-residence at the Center for Astrophysics | Harvard & Smithsonian (CfA), during which time she led a project on preserving indigenous astronomical heritage. As a Jansky Fellow, her research program will make use of NRAO's historical archives and will focus on the history of international cooperation within radio astronomy.



**Samantha Scibelli** (NRAO/Charlottesville) received her Ph.D. in Astronomy and Astrophysics at the University of Arizona in Tucson, USA, in 2023. Samantha's research interests include submillimeter studies of the complex chemistry and physical properties of starless and prestellar cores to investigate the initial conditions of low-mass star and planet formation. During observations for her dissertation, she detected a prevalence of complex organic molecules (COMs) in young starless and prestellar cores in the Taurus Molecular Cloud (TMC), causing her to ask, "How are COMs forming so early?" As a Jansky Fellow Samantha continues to investigate the COM formation pathways using the Green Bank Observatory (GBO) legacy GLUCOSE program in combination with detailed chemical modeling of prestellar cores.

**David Monasterio** (NRAO/Central Development Lab) received his Ph.D. in Electrical Engineering from the Universidad de Chile in 2023, where the focus of his dissertation research was new heterodyne receiver architectures for the next generation of astronomical receivers, like those that will be utilized on the next generation Very Large Array (ngVLA) and other radio telescopes. David's primary research interests are in both heterodyne receivers and RF components design. As a Jansky Fellow David continues his research in new heterodyne receiver architectures, focusing in particular on multiband heterodyne receivers with the possibility to cover the entire RF spectrum instantaneously.

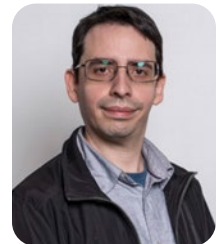

**Cosima Eibensteiner** (NRAO/Charlottesville) graduated from the University of Bonn in Germany in 2023 with a Ph.D. in Astronomy. Cosima's research interests include the structure, evolution, chemistry and kinematics of the interstellar medium (ISM), from large scale disk properties to central molecular zones in nearby galaxies. Her thesis, which utilized data from NSF's Karl G. Jansky Very Large Array (VLA), the Atacama Large Millimeter/submillimeter Array (ALMA), NSF's Green Bank Telescope (GBT), MeerKAT and IRAM, focused on disentangling the physical and chemical processes that shape and govern the ISM. As a member of the PHANGS collaboration, Cosima is studying stellar nurseries in nearby disk galaxies. As a Jansky Fellow at NRAO in Charlottesville, Virginia, Cosima is expanding her research into the effects of the ISM on star formation processes.

**Hendrik Mueller** (NRAO/Socorro) graduated with a Ph.D. in astrophysics at the Max Planck Institute for Radio Astronomy in Bonn, Germany, in 2023. Hendrik's research interests include development of novel VLBI imaging algorithms along the lines of multiscalar imaging in the spirit of compressive sensing and multiobjective evolutionary optimization, which are an improvement in resolution, accuracy and supervision over the CLEAN algorithm, and their applications to frontline VLBI projects in preparation for the next generation of high-resolution and high-sensitivity radio interferometers such as the next generation Very Large Array (ngVLA) and next generation Event Horizon Telescope (ngEHT). As a Jansky Fellow at NRAO in Socorro, New Mexico, Hendrik is focusing on the development of imaging and calibration tools for the ngVLA using artificial intelligence applications.



## Telescope Time Allocations: Semesters 2021A-2023B

In FY2021, the TTA group contributed to the new TTA Software Suite by writing software requirements and testing code. The new TTA Software Suite is being developed in conjunction with DMS as part of the SRDP program. The TTA group investigated gender equity in the TTA review process and published a paper in the Publications of the Astronomical Society of the Pacific (PASP).

The NRAO successfully ran two proposal review processes on February 1, 2022 (Semester 22B with 227 proposals submitted requesting time on the VLA, VLBA, GBT and GMVA) and August 1, 2022 (Semester 23A with 295 proposals submitted) with the final rankings for Semester 23A being sent to the PIs after the TAC meeting in Q1 FY2023. In addition, all the associated software tools to run the proposal calls were updated to accommodate accepting and evaluating PI proposals.

NRAO/NSF signed an agreement with ALMA/JAO on a Joint ALMA/VLA Proposal process. Implementation has begun to offer this capability starting with NRAO Semester 23B and ALMA Cycle 10. New staff have also been assigned to continue the demographic analysis work started with the initial gender bias analysis for accepted proposals.

The NRAO successfully ran two proposal review processes on February 1, 2023 (Semester 23B with 212 proposals submitted requesting time on the VLA, VLBA, GBT and GMVA) and August 2, 2023 (Semester 24A with 331 proposals submitted) with the final rankings for Semester 24A being sent to the PIs after the TAC meeting in Q1 FY2024. In addition, all the associated software tools to run the proposal calls were updated to accommodate accepting and evaluating PI proposals. The proposal call dates were moved to be the closest Wednesday to either February 1 and August 1. A new NRAO Users' Policies was published with the Semester 23B Call for Proposals which supersedes previous policies contained over various webpages and other documentation. Finally, the large program page limit was reduced from 10 to 6 pages and the DDT proposal page limit was reduced from 4 to 2 pages.

NRAO/NSF signed an agreement with both the Neutron Star Interior Composition Explorer Mission (NICER) facility on the International Space Station (ISS) and with JWST to offer joint NRAO/NICER proposals starting with Semester 24A and joint NRAO/JWST proposals starting with Semester 24B. New joint proposals with ALMA were offered in Semester 23B.



### New Assistant Director for Science Support & Research

Dr. Anthony Remijan started as the new NRAO Assistant Director for Science Support and Research in May 2022.

Dr. Remijan began his career at the University of Illinois (Urbana-Champaign), doing his undergraduate work and Ph.D. there. After some college teaching and a stint at NASA, he joined NRAO as a postdoc in 2006, eventually becoming a staff scientist, later Division Head for Scientific User Support and Research, and most recently Deputy Assistant Director for the North American ALMA Science Operations. He spent considerable time commissioning ALMA in Chile, and is well-known for his contributions to several NRAO / Green Bank Observatory instruments and science programs. As AD/SSR, he will work with departments and divisions across both Observatories to expand Science-Ready Data Products implementation and adoption, continue our excellent telescope time allocation process, and develop the science environment at NRAO to support the research needs of our scientific staff. His contributions to ALMA and the North American ALMA Science Center over the past decade, both as a staff member and a leader, have been an important part of ALMA's success.

## Science Ready Data Products

The Science Ready Data Products (SRDP) program seeks to increase the impact of the NRAO telescopes via three approaches: (1) remove barriers to the use of NRAO telescopes to encourage a broader user base, (2) curate a rich archive of science quality data images, and (3) perform automated calibration and imaging of data from NRAO telescopes. The three projects constituting the program are Science Ready Archive and Operations, the VLA Sky Survey, and development of a new suite of Telescope Time Allocation tools. The program has made significant progress on all three of its constituent projects during FY2021-2023.

The Science Ready Archive and Operations (SRAO) project represents the original scope of the SRDP program, focused on pipeline development, operations, and development of the archive; incrementally delivering capabilities through a five-year roadmap.

The SRDP heuristics team finalized the heuristics for an initial implementation of automated self-calibration for VLA and ALMA that was implemented in the pipeline infrastructure. An initial release of the capability was made in June 2023 and some refinements for use in operations were added for the ALMA/VLA pipeline release at the beginning of October 2023. The current self-calibration capability supports single-field data and ALMA spectral scans. While the pipeline capability was being implemented, the team further extended the self-calibration heuristics to handle low signal-to-noise cases better (typically long baselines for VLA and ALMA) and mosaics. The extended self-calibration heuristics are scheduled for pipeline implementation and a release is planned in early 2024 to bring the additional capabilities into the NRAO ALMA User-Defined Imaging capability, prior to deployment to full operations.

SRDP is leading an NRAO Archive Enhancement Project to enable better data discovery and delivery of calibrated data to the users. A release was completed in June 2023 that refactored some workflows to begin providing users with a more intuitive data delivery structure. A subsequent release is being prepared to provide users with more complete and usefully displayed VLA metadata.

The SSR Department through the SRDP program provides project management, requirement definition, and product validation for the TTA tools project.

- The ability to create proposals for the GBT and VLA, which includes proposal information such as the Title, Abstract, and Scientific Justification.
- The ability to capture a user's science request for Continuum and Spectral Line observing types.
- A prototype of Observation Specifications, which contain a Scan List and reflects the intent specified by the user.
- An interface for a proposer to navigate through the proposal creation process and view previously created proposals.
- An interface for Observatory staff to view and modify proposals created by any user, to prototype Solicitation Configuration, and to set messaging on the landing page of the TTA Tools.

## VLA Sky Survey

A joint deliverable with New Mexico Operations, the VLA Sky Survey is the third project managed by the SRDP program. The highest resolution all-sky survey ever undertaken at radio wavelengths, the VLA Sky Survey is a joint deliverable with the New Mexico Operations department. A synoptic survey observing the full sky visible to the VLA in three epochs, between 2–4 GHz, the VLA Sky Survey delivers low-latency QuickLook and higher fidelity Single Epoch images for each epoch of observation. VLA Sky Survey Science covers a wide area of exploration:

**Hidden Explosions:** The VLASS will open up new parameter space for finding supernovae, tidal disruption events, gamma-ray bursts and mergers of compact objects (e.g. two neutron stars).

**Peering through our Dusty Galaxy:** Dust is transparent to radio waves, allowing us to see structures in the Galaxy hidden at other wavelengths. Additionally, the survey will reveal extreme pulsars and cool stars with active coronae that are likely to be variable in the optical and radio.

**The Magnetic Sky:** Our understanding of how and when magnetic fields arose in the Universe is poor. The VLASS will be able to measure the Faraday Rotation of the plane of polarization of radio waves that occurs when they pass through a magnetized plasma. Faraday Rotation is one of the few techniques for finding magnetic fields in space, from the surroundings of radio sources in dense galaxy clusters, to the magnetic field of our own Milky Way.

**Galaxies through Cosmic Time:** Jets of radio-emitting plasma can heat the gas within and around galaxies, slowing the formation of stars. The VLASS will help obtain a full census of these radio jets and AGN, needed to determine whether this heating is sufficient to restrict the growth of galaxies via this feedback mechanism.

**Missing Physics:** Whenever a survey breaks new ground in parameter space there will be discoveries unanticipated by the survey team. The radio part of the spectrum, in particular, provides unique diagnostics for a whole range of physical processes. Combining the VLASS data with ambitious new optical and infrared surveys will inevitably lead to significant discoveries.

The first half of the 3rd epoch of VLASS was completed in 2023 and 99% of QuickLook (QL) images were quality assured and delivered. Also, the first 1130 Single Epoch (SE) continuum images and 12 demonstration SE data cubes were processed with the VLASS pipeline. VLASS has demonstrated running computing jobs at scale showing that more than 1000 imaging jobs can be run at once which is a good test and demonstration for future ngVLA processing which will need nearly 106 jobs processed to keep pace with observations. Finally, VLASS provided impetus for new *aw*-project gridded in CASA, enabling wide-field, GHz-frequency mosaicking at high dynamic range. VLASS will need this for observations at southern declinations. This new algorithm is ~5x faster with Central Processing units (CPU), and using Graphics Processing Unit (GPU) gives another factor of 2x in processing speed. To date, VLASS data has been used in over 118 refereed papers and the VLASS survey description paper (Lacy et al. 2020) has been cited over 340 times. VLASS data is also widely used by NRAO REU student projects (four in FY2023) and is the main topic of the NRAO NINE student projects in machine learning. Given the success of the past several epochs of VLASS, the scientific community has been solicited to provide feedback for a possible 4th epoch.

The VLASS Science conference “*The VLA Sky Survey in the Multi-Wavelength Spotlight*” was held in September 2022 as a hybrid meeting, with over 100 in-person and 100 virtual participants.

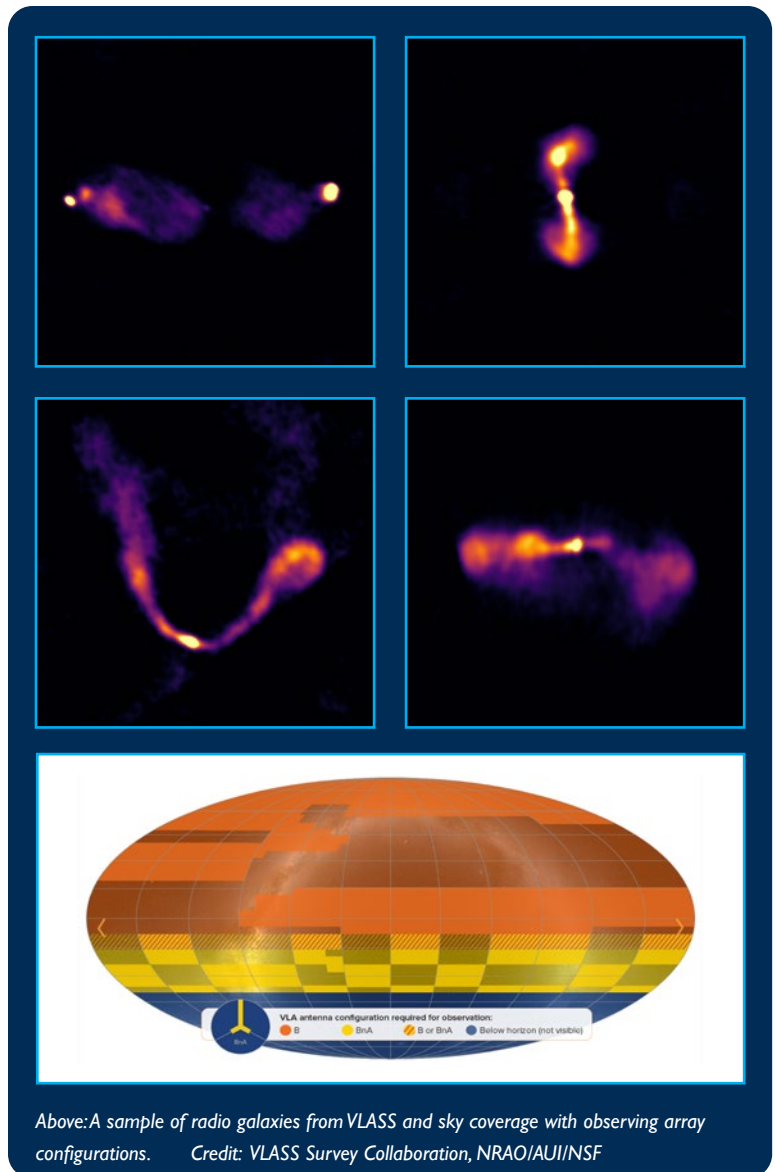

Above: A sample of radio galaxies from VLASS and sky coverage with observing array configurations. Credit: VLASS Survey Collaboration, NRAO/AUI/NSF

### Robert L. Brown Outstanding Doctoral Dissertation Awards

The NRAO and Associated Universities, Inc. (AUI) are pleased to announce that **Dr. Ci Xue** as the winner of the 2021 Robert L. Brown Outstanding Doctoral Dissertation Award. Dr. Xue's University of Virginia Dissertation, "Discovery and Morphology of Complex Molecules toward Interstellar Molecular Clouds," used observations performed with the Atacama Large Millimeter/submillimeter Array, the Green Bank Telescope, and the Very Large Array to explore diverse star-forming dense clouds in the Milky Way. Her remarkable research expands our understanding of the initial chemical conditions of star formation and the voyage of complex organic chemicals as building blocks of bio-macromolecules. The results of Dr. Xue's thesis will guide future projects in astrochemistry for new and powerful instruments to come. Dr. Xue is currently a postdoctoral associate at the Massachusetts Institute of Technology, where she is expanding her dissertation work to study aromatic chemistry in the interstellar medium.



The NRAO and Associated Universities, Inc. (AUI) are pleased to announce that **Dr. Patrick Kamieneski**, currently a postdoctoral scholar at Arizona State University, as the winner of the 2022 Robert L. Brown Outstanding Doctoral Dissertation Award. In his University of Massachusetts, thesis, Dr. Kamieneski developed an innovative use of gravitational lensing to interpret his ALMA and JVLA observations of high redshift galaxies to study the extreme rate of star formation in the distant Universe.

Both receipts received their awards at ceremonies at NRAO Headquarters in Charlottesville, Virginia.

### New Historical Radio Astronomy Books

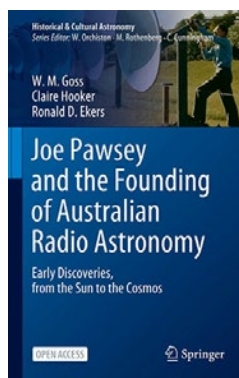

***Joe Pawsey and the Founding of Australian Radio Astronomy: Early Discoveries***, from the Sun to the Cosmos by W. M. Goss, Claire Hooker, and Ronald D. Ekers examines not only the life of Joe Pawsey, but the birth and growth of the field of radio astronomy and the state of science itself in twentieth century Australia. The book tells a previously untold story based on primary sources and explains how an isolated continent with limited resources grew to be one of the leaders in the study of radio astronomy and the design of instruments to do so.

***Star Noise: Discovering the Radio Universe*** by Ken Kellermann and Ellen Bouton tells the fascinating story of the remarkable, mostly accidental, or serendipitous discoveries in radio astronomy that have transformed our view of the Universe. Star Noise is about the men and women who made the discoveries, the circumstances that enabled them, and the unanticipated ways that scientific research really works.





**The ALMA Telescope: The Story of a Science Mega-Project** by Paul Vanden Bout, Bob Dickman, and Adele Plunkett tells the history of the ALMA Project from its earliest beginnings to its inauguration and first decade of science. The ballet that led to the merger of the US, European, and eventually Japanese concepts is recounted. The lucky breaks and near-death crises along the way are documented. Vignettes by key players around the world offer additional perspectives. The book ends by presenting significant science results and addressing several compelling questions: Was ALMA worth the cost and effort? Did ALMA meet its specifications? An Appendix lists some lessons learned along the way, hoping to inform future generations of transformational astronomical mega-projects.

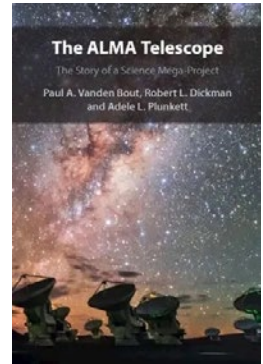

## Scientific User Support

The Scientific User Support (SUS) group provides the scientific community with the support to execute successful scientific programs with the VLA and the VLBA. While the SUS group supports VLA users, the SRDP initiative has a goal to increase that scientific user base beyond traditional radio astronomers. In the longer term, SUS will use the products of the SRDP project to provide the scientific support for users to access, reduce, calibrate, and analyze their data as well as to help the community generate new and innovative ideas for science by fostering cross-disciplinary and cross-field ideas and techniques. Over the course of FY2022, NRAO staff hosted 28 face-to-face visitors for observing and data reduction at the DSOC in Socorro, NM.

The NRAO organized and hosted the 9th VLA data reduction workshop from October 11-20, 2022. The first week was dedicated to lectures by scientific staff and data analysts covering topics related to calibration and imaging of VLA data and pipeline products. The lectures were also broadcast online for the virtual participants, and recorded for future reference. The second half of the workshop was devoted to data reduction by the in-person participants on their own data with the help of the staff. The workshop drew 17 in-person participants, and a similar number online who tuned in for the lectures.

The NRAO organized two community day events (CDE) in FY2023. The first CDE was hosted by MIT Haystack Observatory, and was organized in collaboration with the resident ALMA ambassador. The event took place on April 3-4, 2023, and covered VLA, VLBA, and ALMA topics. Up to 15 individuals participated in this event. The second CDE was hosted by UNAM-Morelia in Mexico on September 28-29, 2023, and also covered VLA, VLBA, and ALMA topics. Forty individuals participated in this event.

The 19th NRAO Synthesis Imaging Summer School (SISS) was held June 13-21, 2023 in Charlottesville. The workshop consisted of lectures on aperture synthesis theory and techniques at a level appropriate for graduate students in astrophysics. The program included discussion groups, and tutorials demonstrating data collection, calibration, and imaging of various types of observations, including new data from the VLA, VLBA, and ALMA. Participants also toured the Green Bank Observatory and were also given the opportunity to participate in lectures and discussions on science and engineering.



### 2021 Jansky Lectureship Awarded to Dr. Luis F. Rodriguez



Associated Universities, Inc. (AUI) and the National Radio Astronomy Observatory (NRAO) awarded the 2021 Karl G. Jansky Lectureship to Dr. Luis F. Rodriguez, of the National University of Mexico (UNAM). The Jansky Lectureship is an honor established by the AUI trustees to recognize outstanding contributions to the advancement of radio astronomy.

Rodriguez is being honored for his significant contributions to the understanding of star formation and X-ray emitting binary star systems, his distinguished career as an educator and popularizer of astronomy, and as a mentor to a generation of radio astronomers. As a member of one of two teams that co-discovered outflows from regions of star formation, he contributed to shaping

the current paradigm of star formation. With Felix Mirabel, he discovered the first microquasars in the Milky Way — nearby and smaller analogs to quasars at the hearts of distant galaxies. They received the American Astronomical Society's Bruno Rossi Prize in 1996 for that work.

In 1992, Rodríguez obtained a grant from the Mexican government to equip the VLA with its first 43-GHz receivers, enabling some of the first images of dust emission from protoplanetary disks around young stars — disks that eventually will produce planets. He was the founding director of the Institute of Radio Astronomy and Astrophysics at UNAM, and is considered the father of radio astronomy in Mexico. As a professor at UNAM since 1979, he has directed 28 student theses. He is author or coauthor of more than 500 scientific publications that have received more than 25,000 citations.

Rodriguez earned a B.S. in Physics from UNAM in 1973 and a Ph.D in Astronomy from Harvard University in 1978. He has received the Mexican Award of Sciences, the most important such recognition given in that country, the Robert J. Trumpler Award of the Astronomical Society of the Pacific, and is one of only 40 members of Mexico's National College, which brings together the country's foremost scientists and artists. He is a foreign member of the U.S. National Academy of Sciences and of the Spanish Royal Society of Exact, Physical, and Natural Sciences.

He now is a Professor Emeritus of UNAM's Institute of Radio Astronomy and Astrophysics, and also is Coordinator of the Mesoamerican Center for Theoretical Physics in Chiapas, Mexico. He is working with NRAO on selecting locations in Mexico for key antennas of the proposed Next Generation Very Large Array.

## 2022 Jansky Lectureship Awarded to Professor Françoise Combes



Associated Universities, Inc. (AUI) and the National Radio Astronomy Observatory (NRAO) have awarded the 2022 Karl G. Jansky Lectureship to Professor Françoise Combes, Chair of Galaxies and Cosmology at the College of France and Astronomer at the Paris Observatory. The Jansky Lectureship is an honor established by the trustees of AUI to recognize outstanding contributions to the advancement of radio astronomy.

Professor Combes is being honored for her significant contributions to the fields of galaxy evolution, the interstellar medium, dark matter, and radio astronomy. Her expertise in a wide range of fields over the course of an outstanding scientific career has extended her influence to the entire breadth of astronomy. She is author of more than

1,200 publications and more than 20 books.

She received a Ph.D in astrophysics from the Ecole Normale Supérieure in Paris, and her work has been recognized by numerous honors and awards. These include Fellowship in the American Astronomical Society, the R.M. Petrie Prize of the Canadian Astronomical Society, the Tycho Brahe Prize from the European Astronomical Society, the Gothenburg Lise Meitner Award, and an Honorary Fellowship of the Royal Astronomical Society. Professor Combes also received the prestigious L'Oréal-UNESCO Award for Women in Science in 2021, where she was recognized for her outstanding contribution to astrophysics with research crucial to the understanding of the birth and evolution of stars and galaxies, including the role played by supermassive black holes in galactic centers.

A longtime scientific editor of *Astronomy & Astrophysics*, she has served in advisory roles for the Atacama Large Millimeter/submillimeter Array, the Square Kilometer Array, the Hubble Space Telescope, and the International Astronomical Union.

Professor Combes delivered her lecture, entitled "*Symbiosis between black holes and galaxies*," covering observations with facilities across the electromagnetic spectrum, including ALMA and the VLA at NRAO and GBO locations in Charlottesville, Virginia, Green Bank, West Virginia, and Socorro, New Mexico.

### 2023 Jansky Lectureship Awarded to Dr. Paul Vanden Bout

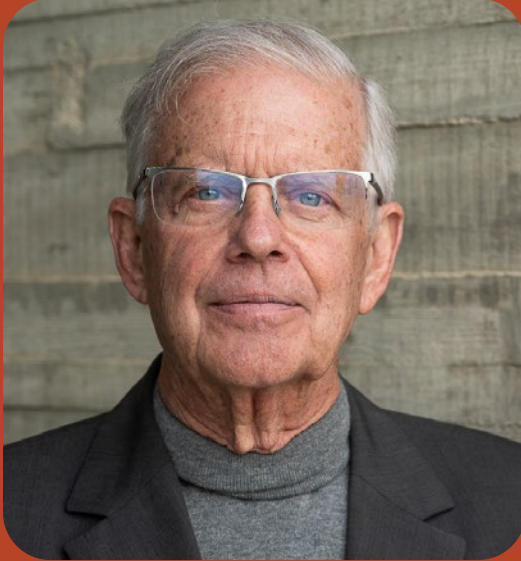

Associated Universities, Inc. (AUI) and the National Radio Astronomy Observatory (NRAO) awarded the 2023 Karl G. Jansky Lectureship to Dr. Paul Vanden Bout, Senior Scientist, Emeritus at the National Radio Astronomy Observatory. The Jansky Lectureship is an honor established by the trustees of AUI to recognize and celebrate outstanding contributions to the advancement of radio astronomy.

During his tenure as NRAO Director from 1985 to 2002, a pivotal moment arose when the Subcommittee on Millimeter- and Submillimeter-Wavelength Astronomy, chaired by Alan Barrett, highlighted the necessity for a large millimeter array. Dr. Vanden Bout played a crucial role in turning this idea into reality, culminating in the creation of ALMA (Atacama Large Millimeter/

submillimeter Array). His leadership was instrumental in forming the ALMA partnership, and he successfully secured funding for the construction of ALMA even before stepping down from his Director position. His vision and efforts have significantly contributed to the radio astronomy landscape in the United States today not just with ALMA but also with the construction of both the VLBA and the GBT and the planning for and initiation of the EVLA project.

After earning his A.B. degree from Calvin College in 1961 and his Ph.D. from the University of California, Berkeley, in 1966, he has remained deeply engaged in scientific pursuits, with a particular focus on interstellar molecular spectroscopy. His primary interest lies in using molecular spectroscopy, especially at millimeter wavelengths, to deduce the physical characteristics of star-forming interstellar clouds. Throughout his career, he has actively served on various committees, showcasing his commitment to advancing scientific research. Some of the notable committees he has been a part of include the LIGO Program Advisory Committee, the NAS Committee on Radio Frequencies, and the NSF Astronomy Advisory Committee. He has also been involved with the American Astronomical Society (AAS) Council, served on several AAS committees, and held the position of AAS vice-president from 2005 to 2008.

His dedication to the field of astronomy extended to being a member of the Committee for a Decadal Survey of Astronomy and Astrophysics for the 2010-2020 decade, contributing his expertise to shape the direction of research in the field during that period. Dr. Vanden Bout has also published a new book with co-authors Bob Dickman and Adele Plunkett, titled *The ALMA Telescope: The Story of a Science Mega-Project*, and tells the history of the ALMA Project from its earliest beginnings to its inauguration and first decade of science.

## Reference Services: Library and Archives

The NRAO Library maintains distributed access to research and reference materials for NRAO staff and the community. Library staff aim to maximize the available resources and new material acquisitions within the operating budget. The NRAO Library is responsible for the publication, posting, and maintenance of 125 NRAO Memo and Report series, newsletters, publications, and collections of instrument-related documentation. All documents the library hosts are used by the NRAO and the scientific community in the operation and development of, and planning for, NRAO instruments and systems, as well as accountability to NSF.

Over the course of FY2023, the NRAO Library supported the publication of 120 papers from ALMA, VLA and the VLBA. The third phase of a comprehensive memos database project to support ease of discovery of NRAO memos and reports expanding author information and connecting authors to memos was underway in FY2023 and will be completed early in FY2024. The establishment of a faceted search index by DMS will close the Library's decade-long digitization project. Results from the first survey of journal subscriptions were collected and will lead to the strategic planning for library operations starting in FY2024.

The Library staff support internal and external reporting functions by collecting a variety of data and metrics in coordination with Statistics and Metrics services. This effort includes standard metrics requested monthly, quarterly, or annually. Closely related to the effort to track the impact of NRAO instruments in the literature, the library administers support for publication charges of qualified authors.

The NRAO/AUI Historical Archives seeks out, collects, organizes, preserves, and provides access to NRAO institutional records as well as personal papers of staff, former staff, and others with connections to the NRAO, preserves multimedia materials relating to NRAO history, and conducts oral history interviews. As resources permit, Archives makes these materials publicly available through an extensively documented web site and personal contact with internal staff and external individuals and organizations. As the national facility for radio astronomy, the NRAO/AUI Historical Archives also includes materials on the history and development of radio astronomy. It is one of the few Archives worldwide that already provides such a wide range of materials online without the need for researchers to physically visit the Archives, and its growing reputation has made the NRAO Archives the de facto repository for the history of U.S. and Canadian radio astronomy.

Over the course of FY2023, Historical Archives completed processing of collections from Bridle and Clark, and added material to several existing collections; hired an external contractor to complete the transcriptions of the remaining 108 Sullivan audio interviews as well as 18 Kellerman audio interviews; purchased additional shelving to house our expanding collection; mounted an exhibit in the Edgemont Road building lobby commemorating Karl Jansky; and hired NRAO's first full-time archivist.

The NRAO Historical Archive chronicles the rich history and milestones achieved by the NRAO. In 2023, the Very Long Baseline Array celebrated 30 years of scientific discovery and engineering design.



*Photo by Jeff Hellerman, NRAO/AUI/NSF*

# DATA MANAGEMENT & SOFTWARE

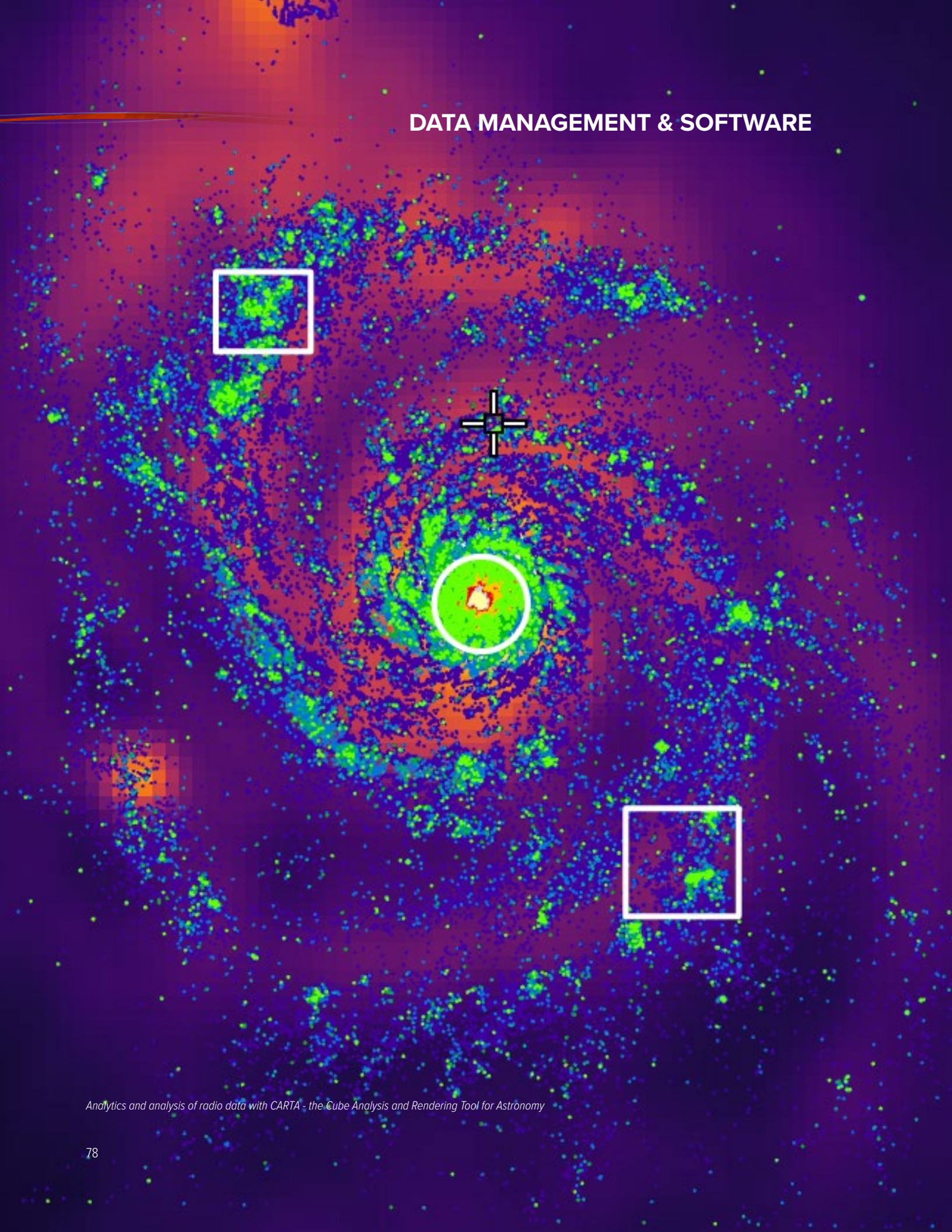

*Analytics and analysis of radio data with CARTA - the Cube Analysis and Rendering Tool for Astronomy*

The **Data Management and Software (DMS)** Department delivers scientific computing infrastructure, software, and algorithms to support current Observatory functions and to develop new capabilities for future needs. The department consists of Scientific Information Systems (SIS), Software Development, and the Algorithm Research and Development Group (ARDG). DMS works closely with the ngVLA project and Information Services. Computing management and personnel supporting the development of the ngVLA project are matrix managed by DMS.

### Scientific Computing Group

The Scientific Computing Group provided technology-driven scientific computing support and was tasked with delivering the next generation of data processing solutions, working in close cooperation with the DMS software division, telescope operations, and external cyber infrastructure partners. In FY2023, the lead of this small group retired. With the reorganization of the SIS division, the responsibilities and remaining members of the SCG were reassigned to the Algorithm Research and Development Group (ARDG) and the restructured SIS Division.

**Testing Scaling of GPU Processing:** The ARDG in collaboration with the Center for High Throughput Computing (CHTC) utilized the htclean distributed imaging library and Roadrunner GPU interface to demonstrate distributed imaging on the Partnership to Advance High Throughput Computing (PATH) infrastructure. Using only up to 10 GPUs, initial results suggest an imaging throughput of 1 TB per hour. The test image has a noise floor of about 0.9  $\mu\text{Jy/B}$ —which already represents the deepest high-resolution image with the VLA.

**Investigate ALMA Unmitigated Imaging:** Prior to the reorganization, the SCG completed a joint effort with NAASC and ALMA staff to investigate and document the performance of CASA and the CASA pipeline and describe the compute capacity required to support unmitigated ALMA science imaging pre- and post-ATCA correlator upgrade.

**Develop Second Generation Cluster Operating System (OS) Support:** Before the reorganization, the SCG planned to work with SIS to develop an updated cluster OS model. This is the first of several milestones which have been replanned for FY2024, as the restructured SIS group focuses on developing the next generation of technical infrastructure at NRAO.

**Planning for DSOC SIS Infrastructure Upgrade:** Development of a plan to replace the aging Lustre filesystem was deferred in FY2023 due to the many changes in the SIS division. This milestone has been replanned for FY2024 as part of the SIS effort to secure the legacy technical infrastructure.

**RADIAL Remote Cluster Compute Support:** Project RADIAL (Radio Astronomy Data Imaging and Analysis Labs) addresses current and future astronomy big data challenges while cultivating a diverse and globally competitive STEM workforce. Although delayed by long procurement times for key components, SIS designed, integrated, and tested a prototype RADIAL cluster. This prototype was used to document procedures for construction and support of remote RADIAL clusters. DMS is currently supporting our partners in the construction of the first node at University of Puerto Rico Mayagüez.

**ALMA Systems Group (ASG):** The ALMA Systems Group was formed in FY2020 to support and manage the ALMA software and infrastructure used by the NAASC for data processing. The ASG is now part of the newly refocused SIS division. The responsibilities of the group include deployment-testing and deployment of the offline software, including the new workflow software ALMA Data Processing Toolchain (ADAPT); maintaining the NA ALMA Archive; triaging issues from NA staff with regards to data processing and workflow; improving local infrastructure; and diagnosing and troubleshooting problems found in verification and validation of the software.

## Algorithm Research and Development Group (ARDG)

The NRAO Algorithm Research and Development Group pioneers algorithms necessary to support the scientific objectives of the Observatory. Currently the expertise within the ARDG is working closely with the ngVLA and ALMA WSU projects to understand the processing challenges posed by the projects.

**Full field polarization imaging:** Shortly after the FY2023 Program Operating Plan was finalized, the development of full field polarization imaging was deprioritized. While still an interesting area of research, the operational use cases have been satisfactorily addressed, and research effort redirected to other areas.

**Wide-scale imaging R&D:** This research project intends to develop imaging techniques which do not assume a scale-invariant telescope transfer function. Existing imaging algorithms require significant down-weighting, equivalent to a significant loss in effective telescope sensitivity, to conform to this assumption.

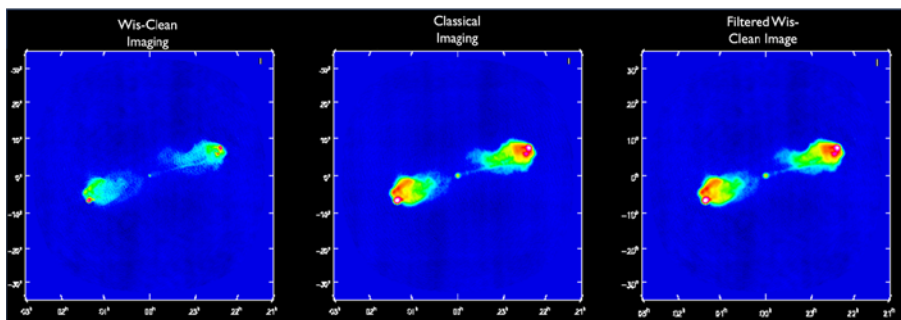

*Left: Results from the new Wis-Clean algorithm. Using simulated ngVLA data we compared imaging performance with Wis-Clean with the imaging performance of classical imaging that requires data down-weighting. By filtering the Wis-Clean image to match the spatial resolution of the Classical image (third panel) direct comparison is possible. This suggests that it is possible to reconstruct the sky emission without sacrificing sensitivity.*

**Memos:** The following memos were published by the ARDG group and are available from the NRAO library at <https://library.nrao.edu/>.

- Bhatnagar, S., Madsen, F. and Robnett, J. *Baseline HPG Runtime Performance for Imaging*. May 2022.
- Hsieh, M. Bhatnagar, S. Hiriart, R., and Pokorny, M. *Recommended Developments for Applying (W)Asp*. March 2022.
- Hsieh, M., Rau, U., and Bhatnagar, S. *Wide-band Implementation of the Asp-Clean Algorithm*. March 2022.
- Bhatnagar, S. *The Design of the AWProject Framework*. February 2022.
- Pokorny, M. *High Performance Gridding*. August 2021.
- Bhatnagar, S., Hiriart R., and Pokorny, M. *Size-of-Computing Estimates for ngVLA Synthesis Imaging*. August 2021.
- Bhatnagar, S., et al. *Full-Mueller Imaging with ALMA: ALMA Study Project Report*. February 2021.
- Hsieh, M and Bhatnagar, S. *Narrow-band Implementation of the Asp-Clean Algorithm*. January 2021.

## Scientific Information Services

The restructured Scientific Information Services (SIS) division is focused on providing the technical infrastructure to support the scientific operations of the Observatory. The SIS division works closely with the Information Technology (IT)-centric Computing and Information Services (CIS) division (Section 9). There are three major functional groups in SIS.

**Computing Operations (NAASC, NM):** These site-based groups directly support the day-to-day telescope operations for reliable data delivery to the archive for pipeline processing, and then the community. They ensure that telescope capability development projects are appropriately staffed, with resources assigned based on commitments and timelines defined within the PMD, and in coordination with local operations support priorities. Projects and milestones for these resources are tracked under the appropriate telescope support sections.

**Networking:** This science data capacity-driven group is responsible for provisioning the long-haul, high-bandwidth connectivity needed to uplink the telescopes and then deliver reliable throughput in support of PI access and general data delivery. Operational support for commodity circuits will be handed off to communication services in CIS once a network service has been accepted into production.



## Software Development

**ALMA System Software:** ALMA priorities are set at the JAO in cooperation with the other partners. Many areas of work depend on coordination with JAO for access to operational resources. The NRAO has worked closely with the JAO and partners to address the highest priorities as efficiently as possible.

**ALMA Control Subsystem, Bug Fixing:** The Control subsystem team spent approximately 50% of its time fixing bugs. Some are latent bugs being discovered as new ALMA capabilities are developed, tested, and used in science operations. Other bugs are triggered by software maintenance activities or changes to the software and/or hardware environment. Critical bugs were fixed as soon as possible and backported to the software used for ALMA operations. Lower priority bugs and bugs found in testing and validation were prioritized and deployed as appropriate in collaboration with affected stakeholders.

**ALMA Sustainability Project - Ethernet-to-CAN (E2C):** As part of the ALMA Sustainability Project, the E2C Project is an initiative to address some of the most pressing obsolescence issues facing the ALMA antennas and the Control subsystem software. The E2C project is an effort to replace the ALMA Bus Master (ABM) units. The ABM is a real-time computer that controls each antenna. Purchased in 2010, these computers are responsible for receiving, translating, and relaying messages from the Control subsystem to the antennas and providing monitoring and status information from the antennas to the Control subsystem. The current ABMs are obsolete and cannot be replaced or reliably maintained. Phase 2 of the E2C project implemented a prototype design for the next generation of real-time computers that adopts standard computer interfaces which can be easily upgraded, moves the real-time code into firmware, uses a new generation of processors, and provides the capability for faster monitoring and control that is expected in the next decade.

**ALMA Sustainability Project - Final Adder (FNL):** As part of the ALMA Sustainability Project, the Correlator team is working on a project to upgrade the interface between the correlator hardware and the Correlator Data Processing (CDP) cluster from DPI/hpdi32 to 10Gb Ethernet. Changing the interface to use 10Gb Ethernet allows the use of commercially available hardware options, industry standard communication links, and well-supported device drivers. In addition, it reduces the number of CDP nodes from 16 to 4, simplifies the data ingestion into the CDP nodes, and allows for debugging with industry-standard tools. During FY2023, the new Baseline Correlator Final Adder Board successfully completed ALMA Product Acceptance In-house (PAI), and the hardware was shipped to the JAO for assembly, commencing the next phase of Product Acceptance On-site (PAS).

**New Advanced Technology ALMA Correlator (ATAC):** The ALMA software team at NRAO obtained funding in January 2023 to commence the next generation ALMA Correlator as a Co-PI with National Research Council of Canada (NRC) to the ALMA Development Program. The ATAC will provide a broad range of new capabilities as part of a five-year proposal with the aim to be ready for science observations in 2029. Foundational project management and systems engineering efforts commenced in FY2023 with preparations for a Systems Requirements Review that will take place in Q1 FY2024 and a Preliminary Design Review in Q2 FY2024.

**ALMA Scheduling Subsystem - Technology Improvements:** In FY2023, the Scheduling subsystem allocated effort to a refactoring of the Dynamic Scheduling Algorithm (DSA) software. This planned activity transformed into a re-implementation of the DSA software stack. A new implementation of the DSA database was delivered with improvements focused on an upgrade of technologies, performance and concurrency improvements, and a mechanism based on custom schemas for cost-free extensibility in terms of new data to be handled on the ALMA Project Data Model (APDM).

**Science Data Model - Performance updates and Improvements:** The Science Data Model (SDM), which is the metadata that describes a given observation and the collected data, is shared between three major stakeholders: ALMA, the VLA, and CASA. The data model is maintained by the software group at the NRAO. Discussions commenced in FY2023 regarding the suitability of the current data model to support the ALMA WSU.

### New Mexico System Software

The responsibilities of this group involve the system software for the VLA and VLBA—primarily monitor and control, but also other operational functions, notably dynamic scheduling.

**VLA System Software and VLBA New Digital Architecture (VNDA):** On an ongoing basis, much of the work involves maintenance, including troubleshooting and bug fixes. Deployments for PI observing use for Semesters 2022B and 2023A occurred as planned in Q1 and Q3, respectively. Software was incrementally made available for commissioning new 2023A and 2023B capabilities in Q2 and Q4. During FY2023, support was provided for major VLA projects including Realfast (fast transient detection), VLASS, and ngVLA. Delays in the VNDA FPGA development resulted in the cancellation of the monitor and control software demonstration that was anticipated in FY2023. A new milestone has been established for FY2024.

**VLA Observing Preparation and VLBA Systems Software Support:** Two software releases for the Observation Preparation Tool (OPT) occurred as planned in FY2023. Version 1.31, released during Q1 and provided a COSMIC SETI off switch mechanism and RCT/SCT improvements. Version 1.3.2 was released during Q4 and provided a mechanism for using RFI blanking and will support wideband VLA recording during VLBI projects. The Q4 release will also include high-priority user enhancements and bug fixes. The related utility, vex2opt, was updated to support wideband VLA recording during VLBI projects. VLBA System Software Support for VLBA commissioning and observing followed the same deployment cycles as the VLA. The NMS group supported work on a new e-transfer file system.

### CASA

Development of the Common Astronomy Software Applications (CASA) package, the NRAO post-processing software, continues to emphasize support for the VLA and ALMA, unlocking the scientific potential of these world-leading telescopes. During FY2023, the NRAO continued to add capabilities in support of current operations while positioning CASA to handle future upgrades to ALMA and the anticipated demands of ngVLA-scale processing.

CASA development continued its more frequent continuous release strategy in FY2023, with up to three releases per quarter, bringing new capabilities, bug fixes, and improvements to the community faster and improving the responsiveness of the development team. CASA continued to coordinate with Pipeline and SSR to provide validated deployments for users.

In FY2021 and 2022, a cross-DMS team investigated the possibility of significantly reducing CASA image processing time via GPU use and demonstrated useful speedups for the VLASS observatory project. In FY2023, CASA integrated this new capability in production software and provided test versions to the VLASS project.

The CASA Next Generation Infrastructure (CNGI) study concluded in FY2021 with a proposed parallel processing framework and data structures. In FY2023, CASA participated in DMS system design efforts and studies to derive an architecture and specification for a next generation CASA. A data model definition project was also begun in collaboration with the SKA consortium. This work continues in FY2024.

Work on the Cube Analysis and Rendering Tool for Astronomy (CARTA) visualization software continued through the collaboration with the ASIAA CASA Development Center (ACDC) and the South African Institute for Data Intensive Astronomy (IDIA) with the intention of improving the user interface and expanding capabilities. With the successful release of CARTA 3.0 in FY2022, most capabilities of the old CASA viewer have been superseded. During FY2023, work continued towards filling a small number of remaining capability gaps.

The ngVLA project has funded work on a prototype antenna, the commissioning of which requires CASA development. During FY2023, CASA began development to support these use-cases, in accordance with project requirements and timelines.

CASA continues its partnership with the Joint Institute for VLBI in Europe (JIVE), supporting tasks to enable the use of CASA for VLBI data. CASA continued to include VLBI/VLBA development work in the continuous releases to the community. Work is underway on VLBA migration to CASA



in conjunction with the work already undertaken by JIVE. During FY2024, CASA will be including VLBI/VLBA development work in the continuous releases to the community.

Additional collaborations are extending CASA use and capabilities. The Australia Telescope Compact Array (ATCA) and Giant Metrewave Radio Telescope (GMRT) support CASA use for reduction of their data products by making a staff member available through the NRAO Helpdesk to answer questions specific to these telescopes. The international CASA development team, led by NRAO, continues to increase support for single dish data reduction and HPC capabilities working on the integration of those capabilities with the standard reduction pipelines. The team continues to add new algorithms based on prototypes from the NRAO ARDG.

**Publication:** Bean et al. 2022. *CASA, the Common Astronomy Software Applications for Radio Astronomy*, PASP, 134, 1041

## CASA Pipeline

During FY2023, the CASA Pipeline supported ALMA, VLA operations, and SRDP/VLASS with a major release for ALMA Cycle 9. For ALMA, the release included:

- Improved QA heuristics and infrastructure;
- Refactored calibration heuristics for faint calibrators (particularly common at high frequencies and low atmospheric transmission) to maximize the information that can be obtained from different calibrator sources with different flux densities;
- Performance optimizations in single-dish processing;
- Inserting additional information in the weblog to facilitate more efficient data reduction quality assurance.
- Review of “renormalization,” the mitigation of fluxscale variations with frequency that can result from ALMA’s correlator normalization scheme.

For the VLA, the release included a generalized compression correction for S-band and L-band, updates to Total Electron Content (TEC) map support, and various smaller improvements and bug fixes. An additional release in Q2 FY2023 supported VLA and ALMA self-calibration in the SRDP reprocessing interface and a pipeline update in Q4 FY2023 provided new capabilities and served as a test release for ALMA Cycle 10.

## Science Support and Archive (SSA)

The SSA group is responsible for the NRAO Archive and most of the user-facing software to support NRAO telescope use. In addition to bug fixes, the group updates the software functionality and user interfaces and provides integration.

**NRAO Archive:** The legacy archive was deprecated in FY2022 and was replaced by the new archive (<https://data.nrao.edu>). In FY2023, SSA continued to enhance the functionality of the new archive and add user-requested features including a scripting query interface using VO technologies. Work on automated data flagging will carry forward into FY2024. Archive work also continued in FY2023 to improve retrieval of image data and to address technical debt in the software.

**Proposal Process Support:** The PST and PHT were updated to support NRAO and GBO observing for the Semester 2023B and Semester 2024A Calls for Proposals, and the PST and PHT were updated for the Semester 2023B and Semester 2024A TAC process.

**Science Ready Data Products (SRDP):** The SSA team’s primary development focus for FY2023 was SRDP. The following goals support SRDP with a theme of image generation, discoverability, and delivery.

- Re-implement VLA Sky Survey QuickLook image product generation to use fewer resources and facilitate processing at other sites, as was done in FY2022 with Single Epoch Continuum imaging.
- Support discovery, retrieval, and CARTA viewing of ALMA Standard images will be carried forward to FY2024
- A deployment supporting production VLASS Single Epoch coarse cube product generation and archiving took place in FY2023.

**Telescope Time Allocation Tools:** In conjunction with the SRDP program, the SSA team is designing and implementing a new suite of tools to support the Observatory time allocation process. The first pre-release version was completed Q4 FY2022. The second pre-release version of the tool suite occurred in Q4 FY2023 and is undergoing user testing.



CENTRAL DEVELOPMENT LABORATORY

*Sub-Kelvin Dewar system.  
Photo by Jeff Hellerman NRAO/AUI/NSF*

The CDL mission is to support the evolution of NRAO facilities by developing the technologies and expertise critical for the next-generation of radio astronomy instrumentation. CDL-developed technology is integral to all NRAO-operated telescopes and to many other radio telescopes around the world, and so, another important mission of the laboratory is providing maintenance and upgrades to these instruments. CDL maintains a staff of approximately fifty personnel organized into teams of engineers and technicians working across crucial radio telescope technologies, including digital design and signal processing; low noise amplifiers; millimeter and submillimeter detectors; optics and electromagnetic components; and new receiver architectures. The laboratory is the world leader in the application of many of these technologies to radio astronomy.

The NRAO, in collaboration with the U.S. radio astronomy community at-large, continued to plan and develop an engineering design for a next-generation Very Large Array (ngVLA) after receiving a favorable outcome from NSF's Decadal Survey. By participating as members of several Integrated Product Teams, CDL actively supported this process throughout FY2021-2023. CDL also supports the greater NRAO mission of developing the next generation of instrumentation engineers and scientists and advancing inclusive participation in science and engineering by:

- Hosting Jansky post-doctoral instrumentation engineers and scientists,
- Hosting post-doctoral and co-op women engineers as part of CDL's Women in Engineering program,
- Advising, mentoring, and employing undergraduate and graduate engineering and astronomy students, and,
- Participating in student co-operative and internship engineering programs.

CDL continued to engage in cross-Observatory repair, maintenance, support, and in several programmatic and work-for-other construction projects. All this while carrying out design and development of technologies for future instrumentation—including for the ngVLA and for ALMA. In addition, CDL continued investigating new and emerging technologies that have the potential to advance the state-of-the-art in instrumentation.

A key component of CDL's strategic plan is establishing talent pipelines into the laboratory. A significant achievement in the effort to establish such pipelines, as well as to address the Observatory's mission of advancing inclusive participation in science and engineering was secured in FY2022 by a grant from the Heising-Simons Foundation to establish a Women in Engineering (WiE) program at the laboratory. This grant continues to support two women co-op students and two women post-doctoral fellowships at the CDL. In FY2023, CDL hired three co-op students under this WiE program.

The WiE program augments CDL's ongoing co-op program, in which eight other co-ops have participated since FY2019. The first former co-op was hired on as a staff engineer in FY2023, bringing to fruition the planned talent pipeline. Additionally, post-doctoral candidates were interviewed and one candidate was offered a Jansky post-doctoral fellowship position in FY2023— this candidate is scheduled to relocate to the CDL and start in the Jansky position in the fall of calendar year 2023.

CDL continues to work with the NRAO Technology Transfer Manager to commercialize technology developed in the laboratory. At present, patents have been issued for 17 CDL inventions, 6 of which have been licensed. One CDL invention submitted in 2023 has non-provisional patent status.

Under NSF's Partnerships for Innovation (PFI) program, work continued in FY2023 to develop high-frequency transmission-line reflectionless filters (existing patents) with Mini-Circuits using their Low Temperature Co-fired Ceramic (LTCC) process. This has the potential to allow use of reflectionless filter technology in ALMA receivers and to significantly expand the commercial market for the devices. At the same time, CDL has successfully prototyped reflectionless filters at millimeter-wave frequencies using advanced thin-film processes from Anritsu Corporation. The thin film process shows promise at even higher frequencies than the LTCC process. CDL has co-authored a paper on this technology with Anritsu that will be published in *Microwave Journal* and is planning to work with Anritsu in 2024 to further refine the process.

## Repair, Maintenance, Production & Support

The CDL core production and support activities for FY2021-2023 are described below.

### Low Noise Amplifiers (LNAs)

The low noise amplifier group continued production, maintenance, and support of CDL-produced amplifiers. In FY2023, the CDL amplifier group provided support for all VLA, GBT, and VLBA receivers in the field (a total amplifier population of about 1000 amplifiers in all). The CDL amplifier group also refurbished ALMA Band 6 IF preamplifiers for the continued upkeep of receivers on the ALMA telescope. The LNA team did this using commercial devices (transistors) from Diramics AG (Switzerland). The LNA team used Diramics devices in rebuilding Millimeter-wave Integrated Circuit (MIC)-based IF preamplifiers for use with ALMA Band 6 mixers. This use of the commercially available Diramics devices is critical, as they serve as a substitute for the Cryo-3 devices used over the past two decades. The Cryo-3 devices are no longer available as their supply has been depleted. The laboratory's LNA group also continues to support the cryogenic amplifier needs of the greater radio astronomical community as Work for Others (WFO) outside the Observatory's NSF award.

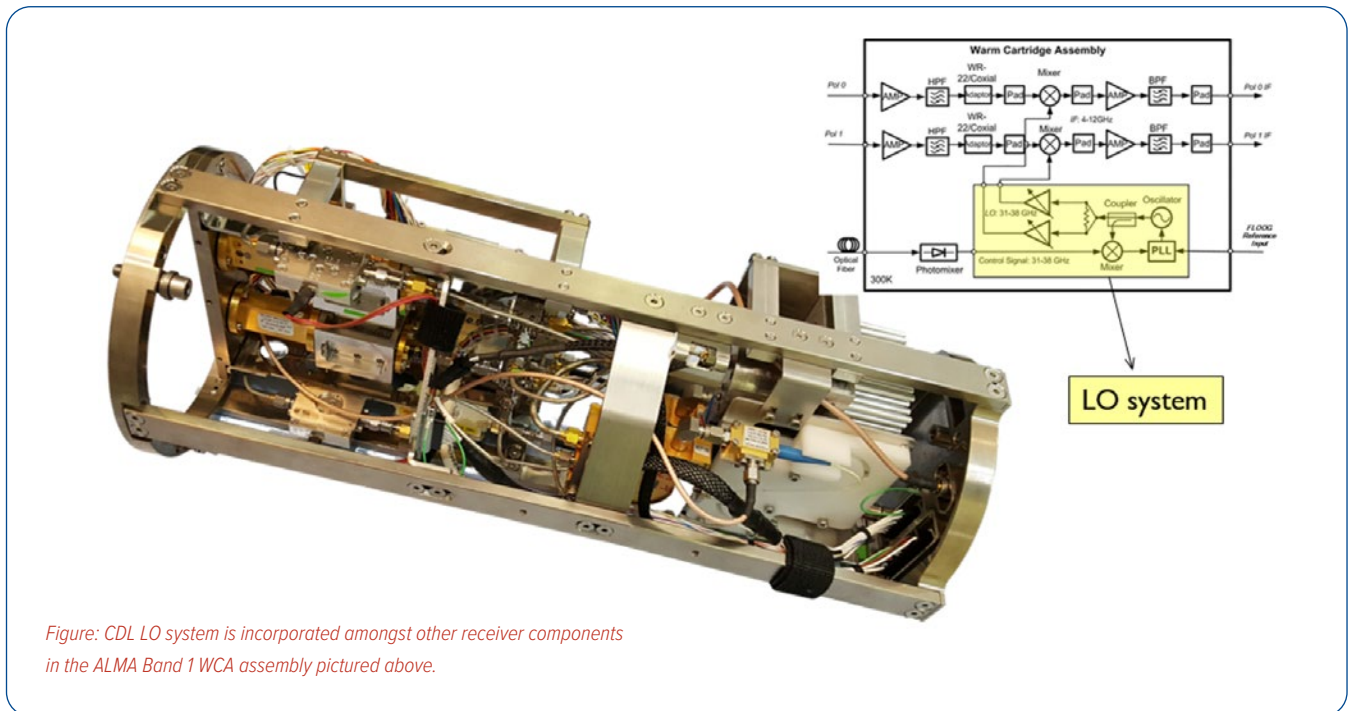

*Figure: CDL LO system is incorporated amongst other receiver components in the ALMA Band 1 WCA assembly pictured above.*

### Millimeter and Submillimeter Receivers (MSMRx)

CDL continued to support the offsite maintenance of the ALMA Band 6 receivers originally built by NRAO, with focus on additionally building a sufficient quantity of spare mixer-preamplifiers. During the same period, CDL also supported community projects and provided consultancy and/or hardware for the South-pole Telescope, and the Taiwanese Greenland Telescope (based on the Vertex ALMA prototype antenna). With the exception of the ALMA support, these activities were outside the scope of the Observatory's NSF award and carried out on a Work for Others (WFO) basis and undertaken only when it did not interfere with work required under the NSF award.

To help with expedited acceptance testing of Band 6 cartridges, one mixer test set and two cartridge test sets were kept operational throughout the year. Progress was slowed due unexpected failures in both repaired cartridges as well as the test set hardware; nevertheless, one repaired Band 6 cold cartridge assembly was shipped to the OSF after completion of all post repair testing during the course of the year. One additional repaired cartridge is nearing its acceptance test completion. The support team is down to the last few broken Band-6 cartridges that need to be fixed, but progress is hindered since very few optics components (specifically, RF horns and OMTs). During FY2021-2023, the team was able to successfully refurbish an old OMT block and return it to use for repairing a cartridge.

### **Integrated Receiver Development**

The Integrated Receiver Development (IRD) group continued to support and nurture NRAO-heritage telescopes such as the VLA and VLBA by providing construction and repair services on the multi-chip modules used in those facilities. The IRD group is uniquely qualified to carry out the specialized design and micro-fabrication tasks for such instruments, and takes seriously its responsibility to keep that institutional knowledge current via cross-training within the group.

### **ALMA Offsite Hardware Support**

The CDL offsite hardware support team provided extensive support to ALMA operations during FY2023, this effort included software and firmware support (bug fixes, implementation of new requested features), providing expertise to diagnose and fix problems during telescope operations, and repairing and returning broken LRUs removed from service. In all, 15 Front-end LRUs (including receiver cartridges), 32 Warm Cartridge Assembly LRUs, and 30 Back-end Local Oscillator and Photonics LRUs were returned to the ALMA site after repairs. A few notable LRUs (not a comprehensive list) that were repaired during FY2021-2023 includes: Band 6 cold cartridge assemblies, FE Monitor Control, warm cartridge/local oscillator assemblies (a mix of various bands), line-length correctors, sub-array switches, fiber optic wraps, BE IF processors, LO Photonic Receiver fiber cables, and LO Photonic Receivers. Lower level hardware repair was carried out on 283 sub-assemblies during this period. Hardware for the FE Test and Measurement Systems including the IF processor modules and tilt tables were also repaired/replaced or worked upon during FY2023. Effort was also initiated with an external vendor to repair LO Reference Test Modules as well as in laser synthesizers. Hardware and software for the bias module test system was also updated, and one copy of this test system was delivered to the OSF laboratory. In FY2023, a FE team comprising of four NA staff members, visited the OSF laboratory during the February shutdown period to provide onsite support by the way of upgrading FE test systems, delivering and commissioning a bias module test set, and assisting with assembly, integration, and verification of the first Band 2 receiver in the ALMA cryostat.

A member of the photonics support group concluded a visit to the hydrogen-maser manufacturer to conduct the pre-delivery in-plant test and inspection of the new hydrogen-maser unit on order for the ALMA observatory. Following this successful visit, the unit is scheduled to be delivered to the observatory in November 2023.

The Ethernet to CAN project (E2C) was another effort that was supported by the offsite support group staff. The E2C project is an obsolescence mitigation effort focused on replacement of the legacy real-time computing platforms with an Ethernet enabled embedded computing platform. During FY2023, phase-2 of this effort was executed and the E2C project team produced a production-quality prototype based on the conceptual design developed during Phase-1. This project entailed both software and hardware components, with the CDL team primarily responsible for the latter. A series of CDL-led in-house and onsite test campaigns in Chile were conducted to validate the design and to help develop appropriate documentation, required for the upcoming critical design review for the project.

In FY2023, the LO support team of the offsite support group was also involved in WFO construction projects outside the Observatory's NSF award. For ASIAA: the team recalled and repaired an LO assembly for Band 1; for The University of Chalmers: the team began the process of qualifying a Band 6 AMC, PA and frequency tripler set. The Band 6 cartridge support team built and delivered a mixer preamplifier set for the East Asian observatory.

## Development Plan

The CDL Research and Development (R&D) efforts supported NRAO Strategic Goals:

- Developing technologies necessary for the long-range objectives of the Observatory.
- Advancing the state-of-the-art in mission-related technology.



*Figure: Family of cryogenic LNAs (from L-band to W-band) developed and built for the Very Large Array and Green Bank Telescope.*

### Low Noise Amplifiers

In FY2022, work was undertaken to design new ALMA Band 6v2 LNAs with optimal noise performance over the extended bandwidth of the project using Diramics devices. The predicted performance was presented in the last annual progress report. During FY2023, a prototype of this design was implemented and tested with satisfactory results over the 4–18 GHz frequency range.

A new line of investigation to develop a capability to design Microwave Monolithic Integrated Circuit (MMIC) based amplifiers, was initiated by the new cryogenic group lead engineer. Such devices would be better suited for populating large arrays like the ngVLA. MMIC foundries were contacted for their design-kit information in order to start using the technology for designing a set of amplifiers that could be used for ngVLA bands 2, 3, and 4, and the MMIC design work was subsequently initiated. A balanced amplifier design, which could eliminate the need for using inter-stage isolators, realized on a MMIC with constraints placed on power dissipation is also being considered by the group to meet future advanced receiver needs.



*Figure: The small size and cost of the iW-RainboW-G35D board is suitable for continued SCREAM development under work-from-home conditions.*



## **MMIC Technology**

In the past, and as is the case with the new Band-6v2 amplifier design described above, the LNA group designed and fabricated amplifiers based on Millimeter-wave Integrated Circuit (MIC, or chip and wire) technology exclusively. For multi-receiver projects which require a large number of amplifiers (such as ngVLA), as well as for designs requiring higher component density, MMIC technology is more appropriate. During FY2023, the Northrop Grumman Corporation (NGC) design kit and process was selected for the first CDL-designed MMIC amplifiers. The first designs are for the lower bands of ngVLA (Band-2 to Band-4; i.e. 3.5 GHz to 34 GHz). Electromagnetic simulations were performed, and the designs were prepared and submitted to the foundry.

## **Millimeter and Submillimeter Detectors (MSMRx)**

CDL and UVA's Innovations in Fabrications Laboratory (IFAB) continued to make progress in developing the technology for the next generation of ALMA receivers, including a new generation of SIS mixers and efforts towards restarting the development of ALMA-compatible Traveling wave Kinetic Inductance Parametric amplifiers (TKIP).

UVA/IFAB completed the first wafer containing the newly designed Band 6v2 SIS mixers in Q4 FY2022. The chips were separated and delivered, and have passed the initial DC I-V characteristic screening. They also meet the target critical current density requirement to enable improved wide-band RF and IF operation. These mixers have been mounted in the chip test blocks (which were themselves described in the last year's performance report), and are awaiting cool down and RF evaluation in the THz-test set. This effort has been delayed because of an accident in the IFAB lab.

The design of a new stand-alone mixer test set for Band 6v2 use was also completed, and most of the components and parts needed to assemble it were ordered during this period. Work was also initiated on the revised layout of the components in the receiver cartridge, in close consultation with the team responsible for the optics design.

During this period, progress was also made with regard to testing the W-band TKIP amplifier prototypes from JPL/Caltech. RF instrumentation hardware procured for the TKIP milli-kelvin dewar during the past reporting period was incorporated into the test system. This hardware and test system were used for evaluating a W-band parametric amplifier at 4 K. Transmission (S<sub>21</sub>) was consistent with the design, but overall, the measurements were too lossy and no gain was measured.

## **Optics, Electromagnetic Components, and Orthomode Transducer Development**

Initial tests on three OMTs of the reverse-coupler design produced results that were inferior compared to predictions. Eventually the problem was traced to missing features due to still mysterious machining errors. This OMT was re-made on a different machine and retested with encouraging results. However, questions related to lateral shift of the two block halves and the impact of plating thickness were studied and remedied on a subsequent fabrication run (on the now repaired 5-axis Matsuura milling machine). Two OMTs of this type were also manufactured commercially. The final version of the reverse coupler implementation of the new Band 6v2 OMT was evaluated during FY2023 and found to meet the system requirements. Four OMTs of the double ridged type were completed in the workshop and tested, yielding encouraging but non-compliant results. Work was carried out on correlating the measured machining tolerances to their measured performance, in an effort to better understand the performance tolerance sensitivity with respect to various mechanical design features.

The Band-6 receiver optics path—a horn, two ellipsoidal mirrors, IR filter, and a vacuum window—were analyzed in FY2023 with the goal to improve cross-polarization levels and correct a sidelobe issue for the Band-6v2 receiver cartridge. It was determined that the existing mirror designs are adequate for Band-6v2; however, evaluation of the current IR filter and vacuum window to correct for cross-polarization issues continues. While direct measurements of these devices are planned by NAOJ collaborators, as a secondary approach to this analysis, the CDL team plans to make measurements on a Band 6v1 receiver cartridge with and without the filters in the cartridge test system. In addition to the Band-6v2 optics work described, the design of the dielectrically loaded quad-ridge feed horn design for ngVLA Band-1 was also finalized.

## CENTRAL DEVELOPMENT LABORATORY



### Digital Signal Processing and Correlators

The digital team completed the hardware, firmware, and software work on the Phase-1 demonstrator of the novel Scalable Reconfigurable Modular (SCREAM) architecture for the ngVLA Central Signal Processor, and successfully tested the prototype to demonstrate its operation including generation of signal spectrum, beamforming, and correlation capability. The SCREAM prototype consists of two beamforming and channelizing (B&C) nodes with basic functionality and a control/gateway node (master FPGA with a built in X-engine). These nodes are implemented on the iWave SoM (System on Module) boards. Interlaken transceivers (up to 150 Gbps) are used for data I/O from the B&C and the gateway nodes.

CDL staff also worked on building and validating a prototype for the new Ethernet to CAN (E2C) modules for ALMA. This hardware is required replacement hardware for the obsolete ALMA bus master computers, and it also forms the platform for enabling future migration of the ALMA M&C system to ethernet bus in order to support the more stringent ALMA WSU requirements.

During FY2023, the E2C was installed and tested at multiple locations at ALMA, including, the digital racks in several antennas (PM03, DA60 and DA63), HiLS correlator rack at the OSF and the computing rack at the AOS. Subsequently, fringes were achieved with a hybrid E2C/ABM system using three antennas. This was a major milestone for the project and validates the E2C concept. A special troubleshooting trip was made in September to determine the cause of a communications bug between the E2C and the FEMC. An updated version of the firmware for the FEMC AMBS11 board resolved the bug, as did disconnecting the Ethernet cable to the FEMC for remote firmware updates. The E2C project is preparing for a preliminary design review and approval for Phase 3, which will involve build out of the eE2C to replace all ABMs in use at ALMA.

## **LO Reference and Timing**

In preparation for a conceptual design review in early FY2024, work continued in FY2023 to follow through and build upon the trade studies and requirement development for the ngVLA conceptual design phase that occurred in FY2022. For the purpose of reference and timing, ngVLA antennas are broadly classified into two categories— the “near” ones that have central timing (nominally, 217 antennas fall in this category) and the “far” ones which have standalone timing (nominally 46 antennas fall in this category). 30 antennas with standalone timing are grouped into 10 clusters of three each with shared timing distribution over local fiber. The remaining 16 are truly standalone with their own reference. The CDL Time and Frequency group continued to be involved in research and development of:

- New techniques for accurate frequency generation, distribution, and synchronization for new and next generation telescopes;
- Leveraging new technologies in optics, lasers, optoelectronics, and fiber optics for radio astronomy;
- Collaboration with industrial and scientific partners in time and frequency research activities in radio astronomy and other fields.

## **LO Group**

Following the delivery of a prototype Band-6v2 local oscillator (Warm Cartridge Assembly) to the Band 6 cartridge group for end-to-end noise evaluation in FY2022, a Band 6v2 LO test plate and an extended RF range beam scanner test source were manufactured, tested and delivered in FY2023. Another Band 6v2 local oscillator is in the works and scheduled to be delivered soon.

The Band-6v2 requirements call for increased IF bandwidth from the present 4–12 GHz, to 4–18 GHz (at least), consequently, the LO AM sideband noise measurement test set needs to be enhanced and validated to support measurements over the increased offsets from the LO carrier frequency. Following a single channel proof-of-concept version that was demonstrated in FY2022 using equipment on hand in the laboratory, requisite components were procured in FY2023 and a two-channel measurement test set with lower LO AM sideband noise to cover the extended frequency range was produced.

A Band-7 WCA built using an alternate commercial HBT MMIC power amplifier was delivered to the OSF for functional testing. This necessitated changes to the firmware to make the operation of this new configuration transparent to higher level ALMA software. The new firmware was regression tested on the telescope before this new ALMA Band 7 warm cartridge assembly was deployed on an antenna. Another WCA with the original GaAs high-electron-mobility transistor (pHEMT) power amplifier, but incorporating an AMC built using the alternate commercial HBT MMIC power amplifier, was also delivered to the OSF and is in use as part of functional testing.

## **Integrated Receiver Development (IRD)**

The IRD program aims to develop compact, mass- producible, and field-replaceable Front-End hardware for the next generation of radio telescope facilities. Goals include: early digitization as near to the telescope focal point as possible; and relatively seamless integration of analog, digital, and photonic technologies into lightweight, low-overhead, Front End modules. The goal is for the architecture to be optimized to exploit the complementarity of integrated construction techniques and Digital Signal Processing, achieving a level of precision and stability that is unmatched by state-of-the-art radio astronomy receivers. The IRD program is working together closely with the CDL Digital Design team.

## **IRD ngVLA Work**

The IRD team continued to support the ngVLA receiver design and prototyping effort. It has completed the design of the analog portion of the RF receiver modules for ngVLA Bands 2 through 6, while that for Band-1 is nearing completion as well. Testing for the Band-2 prototype was completed, and currently the Band-6 is under construction in preparation for its evaluation.

# CENTRAL DEVELOPMENT LABORATORY

## Hydrogen Epoch of Reionization Array (HERA)

This was an ongoing development project, and the remaining goals of this multi-year work package that were addressed during FY2023 included the following: (1) A comparison of an antenna beam measured by the portable OrbComm system deployed at Milton Airfield near Charlottesville, measured by the UAV-based system, and modeled using an electromagnetic simulator. (2) HERA Vivaldi feed evaluation using the UAV-based system. (3) Initial testing of the prototype phase measuring system developed for the UAV. The field work was completed this past summer and the graduate student involved with this effort is currently working on his PhD dissertation..



## Network for Exploration and Space Science (NESS)

The second-generation Cosmic Twilight Polarimeter (CT receiver prototype) was completed. Two variants of the 1/15th scale model of the patch antenna were designed while a third variant is currently being designed; its engineering drawing is expected soon. The ceramic material for this antenna has already been ordered and received. Once the patch antennas are assembled, the beam patterns of all three scale models will be measured in Green Bank. A full-scale version of the selected variant will be built.

## Receiver System for Absolute Flux Measurements with the GBT

During FY2023, remaining modifications to the complete receiver, feed, and backend system that was developed for measuring the absolute sky synchrotron flux at 310 MHz using the GBT, were completed. Ground level drift scans are planned for October 2023, in preparation for the initial 24-hour run on the GBT scheduled for early 2024. The team received a three-year grant from the NSF Astronomy and Astrophysics Research Grants (AAG) program to make the polarized sky map for the low frequency radio astronomy community.

## Next Generation Radar (ngRADAR)

The ngRADAR project is a partnership between NRAO, GBO, and Raytheon Intelligence and Space (RIS) to develop the use of the GBT to transmit and the VLBA to receive radar signals. The NRAO Radar Division and its team members, are located at the CDL.

This team, along with GBO and RIS, started work on a concept design for a high-power, multistatic, next generation planetary radar system, which is funded through FY2023 as NSF Mid-Scale Research Initiative (MSRI-1) award from the NSF. The goal is to develop the full concept design for a high-power phased-array radar to be deployed at the GBT. The system will operate in multi-static mode using GBT to transmit and VLBA array to receive the signal enabling imaging of planetary surfaces, study of planetary structures and spin studies (non-imaging), tracking and imaging of near-Earth objects (NEO) and comets.

In FY2022, trade studies were initiated so as to mature the design for a Conceptual Design Review (CoDR). The design goals include:

- 85% GBT sky coverage (transmit at 13.7 GHz, bandwidth 200-600 MHz), MMIC based phased array with peak radiated power of 0.5 MW.
- VLBA receive, with GBT-VLBA "close-loop" ephemeris correction.
- GBT Transmit + VLBA Receive - comparable or better than Goldstone.
- GBT Transmit + ngVLA Receive - comparable or better than Arecibo.

The effort is supported by an NSF MSRI-1 award, and the key deliverable is a concept design for a high-power (500 kW), high-frequency (13.7 GHz; Ku-band) transmitter on the GBT with reception by the VLBA. The team completed an internal concept design review for the ngRadar project in March 2023 and successfully obtained the supplemental funding for project extension through FY2024. The team continues preparation for an external concept design review, scheduled for Q1 FY2024.

During FY2023, analysis of the proof-of-concept observations were carried out using a low power (700 W) transmitter on the Green Bank Telescope (GBT). Also, in FY2023, GBT radar observations (receiving from Goldstone) helped confirm the success of the NASA Double Asteroid Redirect Test (DART) mission.

### **Advanced Spectrum Monitoring**

In FY2022, this team, located at the CDL, worked to mature the design to the Conceptual Design Review stage, completed the review, and subsequently, began procurement of electronic components, and manufacture of mechanical parts, antennas etc. The mechanical design as well as the construction of the housing for the instrument was completed. Most of the on-order receiver components were received, and the antenna build, electronics circuits, and software design are nearing completion.

The design, construction, and testing of the first ASM prototype receiver took place during FY2023. The original scope of the prototype ASM receiver, which required coverage from 1–120 GHz, was substantially reduced with coverage specified only up to 20 GHz (with no down-conversions) for the initial phase of the project, ASM-1. The prototype was RFI testing in an anechoic chamber at Green Bank and subsequently deployed and successfully completed its field testing over the period of about one week.

Following the completion of testing of the ASM-1 prototype, the ASM-2 project was kicked off with goals to improve upon the shortcomings of the ASM-1 device and addressing the lessons learned during its construction and deployment. The ASM-2 design will follow a modular approach, and cover up to 50 GHz split into four bands: 1–20 GHz; 18–30 GHz; 28–40 GHz; and 38–50 GHz. It will improve upon the sensitivity of ASM-1 by use of improved antennas and their close integration with low noise block downconverters, followed by switching only at the IF (as opposed to the switching at RF used by ASM-1). The LO design will be simple in order to exercise control over unwanted self-generated spurious lines. The system will also incorporate internal noise calibration and initially feature dual polarization sensitivity from 1–20 GHz, but only single polarization observations above 20 GHz. Significant progress was made on the design of ASM-2 during FY2023.



# EDUCATION & PUBLIC OUTREACH



# VLA SPRING OPEN HOUSE

Free Tours & Talks  
GIVEN BY NRAO SCIENTISTS & ENGINEERS

Saturday, Apr 20  
9 AM - 4 PM

FREE ADMISSION  
ADVANCE TIMED-ENTRY  
TICKETS REQUIRED



National Radio Astronomy Observatory

[public.nrao.edu](http://public.nrao.edu) · [VisitVLA.com](http://VisitVLA.com)



The NRAO Education and Public Outreach (EPO) department serves the strategic Observatory goal of increasing public appreciation of and participation in Science, Technology, Engineering, Arts, and Mathematics (STEAM). EPO's four divisions had a busy year highlighting the discoveries, technologies, and careers pioneered and exemplified by the NRAO. In person tours restarted, and visitor centers reopened to the public to share in the exploration and discovery of the NRAO facilities.

## News and Public Information

**Press and Image Releases:** The news division released 144 press products to the public from 2021-2023. Press releases included incredible ALMA and VLA discoveries, VLBA observation results, NRAO milestones, student achievements, and in depth looks at employees and observatory operations. EPO also used Tip Sheets, Announcements, Feature Stories, and social media channels to publicly celebrate milestones, programs and staff accomplishments that are significant to the organization but not likely to be picked up as a press release.

**Blog Entries and Images Gallery:** The EPO group has committed to publishing blog entry stories not driven by individual press releases, but by exploring certain topics in more depth. The public image gallery is also continually populated with spectacular science images, telescope facility photos, and night sky photography. Visits were made to the St. Croix and Owens Valley VLBA station for photography and documentation.



### Beaming With Knowledge

Astrophysical masers are microwave lasers that occur naturally in space. They are found in regions of gas that have...

7 JUN 2023 - By Brian Koberlein



### A Research JOURNEY

The Jets and OUtflows Revealing the Nature and Evolutions of massive YSOs (JOURNEY) Project aims to better understand High...

7 JUN 2023 - By Brian Koberlein



### Small Wavelengths and Big Stars

The birth of a star begins with the collapse of cold molecular gas under its gravitational weight. But once...

6 JUN 2023 - By Brian Koberlein

**Media Outreach:** The Public Information Officers (PIOs) committed to several major media events with two audiences in mind: the researchers who use NRAO data to make discoveries, and the reporters and science writers who bring those discoveries to the public. A number of major science meetings were at the heart of these efforts, the American Astronomical Society (AAS) conferences and the annual meeting of the American Association for the Advancement of Science (AAAS). EPO offers media relation support to users to promote their research and scientific discoveries.

**Communications Training:** As HR expands the onboarding of new managers, the news manager was included in their agenda to emphasize that most employees are not considered spokespersons for the organization and that they should always reach out to the PIOs for media training before talking with the press. In addition to this broad staff training, individuals were coached before their press conferences.

**Spanish Translations:** Contracted services were used to translate press releases and premiere video content into Spanish.

**Liaison with ALMA Partners:** As part of the NRAO collaboration with the ALMA partners, the EPO Public Information Office coordinated its ALMA media relations efforts with the partners and the JAO through monthly telecons. This ensured the broadest possible exposure for ALMA news while maintaining the autonomy and individual outreach goals for each partner.

## EDUCATION & PUBLIC OUTREACH



*Photo by Bettymaya Foott, NRAO/AUI/NSF*

**ngVLA Communications Plan:** A new Public Information Specialist was hired in June 2023, and together with the News and Press Information Manager and NRAO Director, an existing ngVLA Communications plan was reviewed. Revisions are being implemented and a FY2024 release of the plan is expected.

**Social Media:** Social media provides a platform for unique content and to amplify the distribution of new content on the NRAO public website and press products. In addition to regular blogs on the NRAO public website, four social media platforms are maintained: Facebook, Twitter (X), Instagram, and LinkedIn all have a different format and audience.

### Multimedia Engagement

A dedicated, creative team of animators, artists, illustrators, designers, writers, and web developers designed and developed unique multimedia materials, in support of the news and information page, social media, and STEAM efforts, as well as creating new products that were distributed through the public-facing website, school programs, and the VLA Visitor Center.

**Press Products and Revised/Improved Image Gallery:** New workflows have been developed to keep the public-facing gallery populated with the latest images from press releases and other multimedia group projects. The overall gallery was still a challenge to search for particular images, so the organization and tagging of images was revised.

**Baseline Hosted Videos:** This is an original product of the Multimedia Group, that can be viewed on [public.nrao.edu](http://public.nrao.edu), [vimeo.com](https://vimeo.com), and YouTube in the Baseline playlist. The Baseline series transitioned to a short-form style in the attempt to reach an even larger audience.

**Year in Review Videos:** The top news highlights were once again created in partnership with Bad Astronomer host Phil Plait. They are released early in 2022, highlighting the discoveries in 2021.

**NRAO Brand and Style Guide:** This is a work in progress. As new projects are developed, like Augmented Reality, they are being added to the scope of the style guide.

**Augmented Reality:** Augmented reality was developed for press releases, but the first applications of it were for our telescope pages on the public website. Along with the fast facts for each facility, a 3D model of the ALMA 18m dish and the VLA 25m dish were placed on the website. The public can





interact with the 3D model, on the computer with a mouse or through the camera of their mobile device, they can bring the model into their room or space with them.

**Virtual Reality:** A central landing point has been established for the NRAO VR tours, with portals to each of the possible destinations. Within the ngVLA portal, there is now a simple way to view each of the science case videos in an interactive way.



**VLA Walking Tour Signs:** A new set of signs featuring updated content, including ngVLA information, were installed in July. They replaced the existing set that had been on site for approximately ten years. The installation and some custom fabrication of posts and mounting hardware was completed by the VLA Facilities team in record time.

**Blog:** Public website blogs are an opportunity to give a voice to diverse participants and provide an informal avenue to promote stories and information about the Observatory and the people connected to it, and will be published quarterly by Brian Koberlein.

**VLA Legacy Photography:** Bettymaya Foote was contracted to visit the VLA quarterly to capture day and nighttime images of the VLA throughout the year and in different configurations. Escorted by NRAO's art director, a spectacular series of images have been added to the image library.



*Photo by Bettymaya Foote, NRAO/AUI/NSF*

## EDUCATION & PUBLIC OUTREACH

A major pivot that happened with social media during the pandemic was a series of Facebook live events. Seven events were hosted as well as major support of the virtual tours offered by the STEAM Ed staff in lieu of touring visitors at the VLA.

### STEAM Education and Outreach

#### Lesson Plan Development:

The NRAO STEAM Education team designs teaching and learning experiences for K-12 learners, with the exception of authentic research experiences for undergraduates that are managed by colleagues in SSR. Initiatives for FY2023 include the following:

**Virtual Outreach:** An increase of in-person tours and events limited the ability to also hold virtual events. However, new virtual outreach events have been requested and scheduled providing opportunities to reach a global audience.

**VLA Tours:** In-person tours at the VLA have been numerous. Two part-time tour guides were recently hired to help meet demand.

**VLA Open House:** The Spring Open House was a great success. More than 700 guests were received at the site. The addition of food trucks and more interpreters enhanced the visitor experience.

**Staff Outreach Tracking:** The Google Form developed by the STEAM Ed team has proven to be a useful tool, and has allowed NRAO staff volunteering at outreach events to get the support they need to be successful.

**Stakeholder Engagement with Local Communities:** In New Mexico, new relationships were established with Alamo School, the NM State Fair Science and Technology Day team, STEM Challenge Schools and multiple home school groups, as well as the Northern New Mexico STEAM Collation. In Charlottesville, the NRAO partnered with Starr Hill Pathways and Girls Geek Day, and strengthened the collaboration between the NRAO and UVA Astronomy resulting in an increased number of events and students reached.

**Virtual Reality:** A variety of events utilizing VR capabilities were held both in the Charlottesville area and in Albuquerque. New outreach events have been scheduled for the Fall. EPO partnered with New Mexico STEMarts as VR content experts and presenter. EPO continued collaboration with Engage to create the “Path of Light” animation which explains the process of collecting radio light from space and how images are created. ngVLA antennas were updated to the latest design and a new ALMA VR scene was created. In addition, development began on a molecular cloud VR experience.

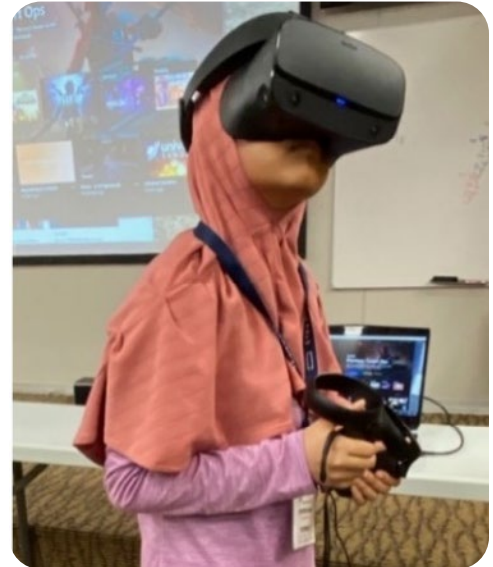

The NRAO public website is rich with new and sometimes interactive content (e.g., colorizing app and interferometry app). The STEAM team worked with the African American Teaching Fellows (AATF) STEAM Education Think Tank in Virginia to create a suite of lesson plans that are available for testing.

**Sister Cities and Observatories:** This NRAO-funded program partners two high school students and a teacher near the VLA in New Mexico with two high school students and a teacher near the ALMA site in northern Chile in a joint cultural/learning exchange, using a scientific experiment as a connecting thread of inquiry. This 10-day exchange seeks to reinforce the school curriculum through STEAM education activities. The emphasis this year will be to expand the shared experiences of the two cohorts leveraging the packaged STEAM Education lesson plans. A commitment and involvement will be required by students and school teachers from New Mexico and the Likan Antai C-30 School in Toconao, Chile. The students

and teachers will be responsible for participating in shared research experiences and for being ambassadors in local schools. EPO staff will work with teachers and students to refine their proposed curriculum projects. Travel for the New Mexico cohort was cancelled because of the pandemic.

**Outreach Events:** Most outreach events have been postponed during the pandemic. Before the shutdown, the STEAM Ed team participated in community events in local Socorro schools including Sarracino STEAM Night, Enchanted Skies Star Party, Festival of the Cranes, and San Antonio Elementary Science Day. The one virtual outreach event was for Project Rousseau, which hosted EPO educators in a classroom Zoom visit.

**VLA Visitor Experiences:** As a team, the STEAM Ed group completed certified interpretive guide training. This is a shift in mindset from specific content-learning goals to creating interpretive experiences at the VLA that are audience centered and mission driven focused. These skills will be applied to the revised virtual tours.



## Visitor Center Operations

NRAO operates a visitor center at the VLA, west of Magdalena, NM. The site has indoor and outdoor public exhibits, a small auditorium, a gift shop, and monthly tour program. The VLA serves local and international students and tour group. Many international visitors and groups were able to virtually tour the VLA from 2021-2022.

At the start of FY2023, the Visitor Center (VC) was reopened to the public after being closed for almost two and half years due to the COVID pandemic. New ticket selling and Point-of-Sale systems were in operation, as will an advance online sale ticket option. The goal for FY2023 is to increase the number of schools able to visit the site on field trips to lay the groundwork for the ngVLA milestone in FY2024 of engaging with sixth grade classes across New Mexico.



# MANAGEMENT & ADMINISTRATION



## Senior Management Organization

The NRAO organization from 2021-2023 consisted of departments, which were made up of divisions, which consisted of groups. This organization emphasizes Observatory-wide management and coordination in key areas, including Program Management, Data Management and Software, Education & Public Outreach, Science Support & Research, and Science Communications.



**Phil Jewell** continued as Assistant Director for the North American ALMA department. Jewell oversees the NA ALMA Science Center and the ALMA Development Program, coordinates the ALMA maintenance program, and is the face of ALMA to the North American scientific community. Jewell also continued in a part-time role as the NRAO Deputy Director.

The New Mexico Operations department, based in Socorro, was led by Assistant Director **Trish Henning**. New Mexico Operations includes all NRAO staff engaged in the operation, maintenance, calibration, performance, and further development of the scientific capabilities of the Jansky VLA and the VLBA.



**Faye Giles**, Assistant Director for Human Resources, directs Observatory-wide human resources policies and programs; including compensation, benefits, recruiting, employment, employee relations, organizational development, performance management and training.

The Program Management department (PMD) led by Assistant Director **Diane Paulson** provides program and project management support and systems engineering services to NRAO project leaders and PIs. The PM department strives to: provide visibility, transparency, and consistency in reporting within NRAO and externally to NSF and outside partners or customers; identify and provide resources for program management and systems engineering needs across all NRAO projects; review new projects for alignment in supporting the Observatory's long-term strategic goals; and compile deliverables.



Assistant Director **Barbara Gruber** leads the Education & Public Outreach department. The NRAO EPO program provides major components of the public's return-on-investment, marshaling NRAO resources in support of Science, Technology, Engineering, Art, and Math (STEAM) education. EPO also inform the science-interested public about the Observatory, its facilities, and the latest technical and scientific achievements of its users and staff.

The Data Management and Software (DMS) department led by Assistant Director **Jeff Kern** manages data archiving at NRAO, including access, distribution, provisioning, and operations. DMS manages the data reduction pipeline infrastructure implementation and technical operation; high-performance computing platform definition, acquisition, and operation; and network provisioning to the external community and between sites. DMS also has primary responsibility for all user-facing and telescope software.



The Central Development Laboratory (CDL) led by Assistant Director **Bert Hawkins** supports the evolution of NRAO's existing facilities and provides the technology and expertise needed to build the next generation of radio astronomy instruments. CDL accomplishes this through development of the enabling technologies: low-noise amplifiers, millimeter and submillimeter detectors, optics and electromagnetic components, including feeds and phased arrays.

## MANAGEMENT & ADMINISTRATION



Based in Charlottesville and led by Assistant Director **Laura Lockledge**, the Administration department provides the administrative and non-programmatic services to NRAO; including: business services, contracts and procurement, environmental safety and security, management and information systems, and technology transfer. **Jason Jennings** is the Charlottesville-based Assistant Director for the NRAO Budget Department, leading a team of fiscal and accounting experts.



Assistant Director **Anthony Remijan** leads the Science Support & Research (SSR) department. SSR is responsible for the Observatory's scientific interface to the NRAO user community. This Observatory-wide department also coordinates, aligns, and manages the collective efforts of scientific staff in Charlottesville and Socorro.



The NRAO / AUI Office of Chilean Affairs (OCA) supports the interests of the Observatory and its parent organization, AUI, in Chile, particularly the North American participation in ALMA. Led by Assistant Director **Paulina Bocaz**, OCA provides ALMA with legal, payroll, and travel support, and provides the legal and institutional support for numerous contracts and procurements for ALMA Operations in Chile.



The Science Communications Office (SciCom) led by **Brian Kent** is also attached to the Director's Office and is responsible for communicating NRAO science, accomplishments, priorities, and plans to the science community, the NSF, and other key external stakeholders. The office leads the NRAO exhibitions at science, engineering, and technical conferences worldwide.

The NRAO Chief Scientist, **Chris Carilli**, also reports to the Director about the Observatory's scientific mission and community requirements.





FESV 1

## Spectrum Management

### VLA and VLBA Radio Frequency Interference Mitigation

Spectrum management is a regulatory process whereby spectrum is apportioned into bands that are allocated to various radio services and applications, subject to rules intended to shield them from mutual interference. Spectrum allocations and spectrum rules are formulated at national and international levels. The NRAO participates in national and international spectrum management to protect and improve upon observing conditions for all astronomers, and has done so since its inception.

In the coming decades, the radio spectrum will become increasingly crowded at ever higher frequencies, and the NRAO will need to remain aware of threats and build both internal and cooperative (external) capabilities to use the spectrum in flexible ways.

The ability to observe without harmful radio frequency interference (RFI) is fundamental to NRAO science. The NRAO undertakes a variety of activities directed at understanding existing and emerging RFI sources, and maintaining a clean electromagnetic environment at and around its facilities. Activities include testing of installed equipment, formulating rules regarding operation of installed and visiting equipment, and mitigating or remediating externally interfering sources. The main areas of activity for Spectrum Management at the NRAO are: (1) Site Spectrum Management, (2) National and International Spectrum Management, (3) activities related to the NRZ Project, and (4) the regular monitoring and concurrence duties (Zone Regulatory Services) of the National Radio Quiet Zone (NRQZ) and the Puerto Rico Coordination Zone (PRCZ).

### VLA and VLBA Radio Frequency Interference Mitigation

The NM Operations Interference Protection Office coordinates spectrum usage for the VLA site by:

- (1) Responding to requests for Special Temporary Authority submitted through the NSF from the National Telecommunications and Information Administration (NTIA). The requests are analyzed for their potential impact to radio astronomy observing by performing propagation simulations and mapping terrain profiles, calculating the expected power flux density at the array antenna, and comparing the results to internationally recognized detrimental interference thresholds. Negotiations with the active spectrum user are conducted to limit, reduce, or eliminate the potential interference.
- (2) Informing external spectrum users at the U.S. Space Command, the tethered aerostat radar system (TARS) sites, and other military and commercial shared-spectrum users of NRAO and Arecibo Observatory planned spectrum usage each month. Jointly used spectrum may then be scheduled on a first-come-first-served basis, by priority, or by prior cooperative agreements.
- (3) Monitoring VLA site spectrum conditions using array observations and external monitoring equipment, and reviewing the resulting spectral plots and observer reports to detect new, unknown RF emissions. Detections in spectrum allocated to radio astronomy trigger source identification and technical discussions with the responsible spectrum user. Particularly detrimental emissions in non-radio astronomy spectrum allocations lead to goodwill discussions with the responsible spectrum user with the goal of interference reduction or elimination via technical means.
- (4) Performing RF emissions tests on incoming commercial or NRAO-designed equipment and reviewing the results to determine interference potential. Equipment found to exceed the detrimental limits is either rejected, modified, shielded, or submitted for re-design.

### National Spectrum Management

The NRAO comments on issues arising at the Federal Communications Commission (FCC) as they occur. The NRAO will continue to participate in the domestic activities of International Telecommunication Union Radiocommunication (ITU-R) Working Party 7D for radio astronomy, hosted by NSF, and other working parties hosted at FCC and NTIA. There is also a continuing interaction with the National Academies Committee on Radio Frequencies (CORF) and a presentation at their annual open meeting in May every year.





Photo by Chris De Pree, NRAO/AUI/NSF

## MANAGEMENT & ADMINISTRATION

The NRAO made six FCC filings in FY2023, mostly concerned with satellite communications with cell phones. These filings included responses to:

- Apple-Globalstar and Android-Iridium deals that will make cell phones behave like satellite phones, but without implementing the rules that apply to Globalstar's and Iridium's own phones. Low bandwidth use in spectrum is already implemented by Globalstar/Iridium. This possibility is less impactful than Direct to Cell (D2C).
- D2C satellite communication with cell phones in cell phone bands. SpaceX has outfitted 2000 Gen2 Starlink satellites w/ German-made L-band transmitters (1.6–2.7 GHz). Similar operations have been previously proposed by AST&Science (ASTSpaceMobile) and Lynk, Global. AST's ¼-sized 64m2 prototype is already one of the brightest objects in the sky. AST's final system would consist of ~256 full-sized systems.

The main problem with D2C proposals is that they moot the protections of radio quiet zones where RFI in cell phone bands has been coordinated away on the ground but will be introduced from overhead.

**Coordinated RFI Monitoring at Other AUI-Managed Observatories:** The GBO also has an Interference Protection Group (IPG) that is charged with monitoring local RFI conditions. This group meets biweekly and consists of scientific and technical personnel at GBO. GBO has also developed a highly capable RFI GUI for internal users, and is in the process of developing an online version of the GUI. ALMA has a number of scientists that are assigned to RFI issues at the Atacama, Chile site.

### International Activities

The NRAO spectrum manager served on the Scientific Organizing Committee (SOC) of the 2nd Workshop on Dark and Quiet Skies for Science and Society that was held in La Palma, Spain, in October 2022, again leading the radio astronomy working group. This meeting reined the recommendations from the first workshop in October 2021 that were presented at the April 2021 Meeting of the U.N. Committee on Peaceful Uses of Outer Space, for reconsideration at the 2022 meetings of that group and its Scientific and Technical Subcommittee. The NRAO spectrum manager was on the SOC for RFI2022 held in Reading, UK, 14–18 February 2022 to consider interference to radio astronomy and remote sensing with a new discussion of effects on meteorology given the host location at the European Center for Medium Range Weather Forecasting, (ECMWF). Adverse spectrum management decisions regarding 5G operations near 2.4 GHz have the potential to greatly impair weather forecasting.

The NRAO spectrum manager participates as a member of the Lunar-Martian Steering Group of the Space Frequency Coordination Group, representing the interests of radio astronomy in preserving the shielded zone of the Moon for future scientific activity in the face of new initiatives by the U.S. and other nations to exploit the lunar surface commercially under NASA's Artemis Accords. Commercial plans foresee implementing the current frequency arrangements used on Earth and in orbit about the Earth in the lunar environment, limiting the Moon's ability to provide a uniquely quiet RF environment for research in the shielded zone on the side facing away from Earth.

Both the NRAO spectrum manager and deputy spectrum manager attended ITU-R meetings in April and September 2022. The NRAO spectrum manager attends these meetings in person in his position as chair of IUCAF (Scientific Committee on Allocation of Frequencies for Radio Astronomy and Space Science), which is chartered by the International Council for Science. The deputy spectrum manager attends as part of the U.S. delegation.

Preparations for WRC-23 at ITU-R are in full swing with a full schedule of Working Party meetings that are once again taking place in Geneva. The NRAO spectrum manager attends these in his position as Chair of IUCAF, the Scientific Committee on Allocation of Frequencies for Radio Astronomy and Space Science, which is chartered by the International Council for Science. The NRAO Spectrum Manager was involved in the preparation for ITU-R Radio Assembly and WRC-23 in Dubai, November 13 to December 15, 2023. Key areas: (1) trying to preserve protections for radio astronomy that are embedded in draft treaty text, and (2) trying to influence agenda items for WRC-27 to consider radio astronomy adequately.

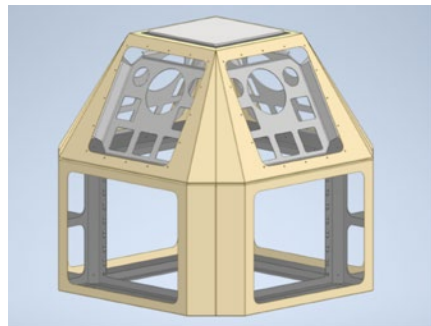

*The ASM-2 enclosure is being redesigned based on lessons learned from ASM-2, deployed and tested at the GBO in May 2023.*

## National Radio Dynamic Zone (NRDZ)

The NRDZ project began in 2021, and with additional funding that arrived in 2022 (SII-NRDZ), has been able to expand its goals and mission. The NRDZ project is now fully staffed with the hiring of an RFI Scientist, and RFI Data Analysts for VLA and GBT data. The NRDZ project is divided into three parts: (I) Concept Definition, (II) ASM, and (III) Broader Impacts. The Concept Definition and Broader Impact portions of the NRDZ project were completed in FY2023, with the ASM work continuing into FY2024. The additional funding of a SII-NRDZ grant (PI: Chris De Pree) will allow NRAO to explore (1) improvements

to the ASM device and (2) a pilot program entitled Operational Data Sharing (ODS) for sharing telescope status with satellite network operators.

**Concept Definition:** NRDZ Lean Coffee events and Workshops, co-organized with SUNY-Albany and the U.S. Naval Academy (USNA) led to the definition of a number of stakeholder requirements for an eventual NRDZ and the ASM device in 2022). These requirements were shared with the NSF for NSF to formulate a new call (SII-NRDZ-STUDY and SII-NRDZ-EEL). NRDZ Project Director was co-author on an IEEE Radio Communications paper and a popular article in *The Conversation* in FY2023. The NRAO participated in Spectrum Week/NRDZCOM2 at NSF in Spring 2023 and plans to present at NRDZCOM3 in Fall 2023.

**Advanced Spectrum Monitor (ASM):** In FY2023, the CDL completed and tested the first ASM prototype (ASM-1) at the CDL and GBO sites. These initial tests provided input and lessons learned for the design of ASM-2 that will undergo a CDR in November 2023. Current NRDZ-ASM related milestones and associated deliverables are covered by CDL.

## Zone Regulatory Services (ZRS)

In early summer 2023, the NRQZ PA was promoted to Zone Regulatory Services Coordinator, overseeing both the NRQZ and the PRCZ. The ZRS Co-ordinator is in close contact with the GBO/IPG group, meeting biweekly and updating other members of this group about current and upcoming NRQZ activities.

**National Radio Quiet Zone:** The National Radio Quiet Zone (NRQZ) was established by the Federal Communications Commission (FCC) in 1958 to minimize possible harmful interference to the NRAO in Green Bank, WV and the radio receiving facilities for the United States Navy in Sugar Grove, WV. The NRQZ encloses a land area of ~13,000 square miles, mostly in Virginia and West Virginia.

The NRQZ office is continuing the reconfiguring of the concurrence application process from an email-based system to a helpdesk system, with a new helpdesk becoming operational in Q1 FY2023. Internal and external documentation on the NRQZ process was completed in Q2, and computational and archiving machines were moved to NRAO-CV. The NRQZ received additional NSF support to make the concurrence application process simpler and web-based. NRAO plans to start piloting web-based submissions to the NRQZ by Q4 FY2024.

In FY2023, the NRQZ office began the process to visualize completed applications around GBO, with a focus on location, transmitter power, and frequency.

**Puerto Rico Coordination Zone:** In August 2023, NSF provided funding to the NRAO to take over coordination efforts in the PRCZ through 2026. The NRAO hired an experienced spectrum manager and telescope operator from Arecibo to serve as PRCZ Program Administrator. The PRCZ PA is working closely with the ZRS Coordinator to document and update concurrence processes in the PRCZ. PRCZ processes are now documented on the NRAO website.

## MANAGEMENT & ADMINISTRATION

### Science Communications

The Science Communications Office (SciCom) collaborated with the Observatory's scientific staff, senior management, and Director's Office to communicate the NRAO vision, science, accomplishments, and plans to the U.S. and international science communities, NRAO/AUI staff, and key external stakeholders, including NRAO advisory committees and the NSF.

SciCom managed a large island exhibit at the June 2022 AAS Conference in Pasadena, California, along with a Town Hall reception, hosting the astronomical community, user base, and new students in person.

SciCom participated in the November 2022 National Society of Black Physicists (NSBP) conference with our exhibit displays and prominent placement in the conference lobby. The NRAO was able to promote opportunities and research to student and faculty participants. The NRAO and Charlottesville hosted this annual conference.

The FY2023 winter AAS conference was held in Seattle, Washington, from January 7-12, 2023. The NRAO sponsored three special event proposals. The first splinter session on *NRAO Science Ready Data Products using the VLA Sky Survey* allowed users to access, understand, and utilize the archived images and catalogs from this large community driven initiative. The second special session informed the astronomical community on plans for increasing the capabilities of ALMA, including the WSU. The third special session examined *Chemical Probes of Astrophysical Systems with ngVLA*. In addition to the NRAO exhibit displays, the Observatory hosted a Town Hall reception so that meeting attendees could interact with NRAO staff and learn about the latest science capabilities. The NRAO and AUI also participated in the REU and Grad Student Fair event. This event has grown in recent years as young students and recent graduates are interested in educational and employment opportunities during their university years and beyond.

SciCom sponsored a large exhibit at the American Association for the Advancement of Science (AAAS) annual conference in Washington, DC from 1-6 March 2023. As a prominent display representing the astrophysical sciences, the NRAO was able to showcase facilities and science to the broader scientific community.

SciCom participated in the joint ngVLA-SKA New Horizons conference from May 1-5, 2023 in Vancouver, British Columbia. The conference explored the science and synergies between these two large observatory projects. Over 300 attendees gave talks and posters on science covering three frequency decades that will be observed by these facilities.

The FY2023 summer AAS conference was held in Albuquerque, New Mexico from June 4-8, 2023. The NRAO sponsored two special session proposals. One event showcased *An Explorer's Guide to the VLA Sky Survey*. The second splinter session gave community members an update and forum on the ngVLA. Both sessions were hybrid, growing the participant list.

A joint event between manufacturing partner *mtex antenna technologies* and NRAO was held September 26-29, 2023 in Leipzig, Germany. The week started with a Germany Science symposium with the ngVLA, and included participants from the American and German science communities. A large event at the new Leipzig mtex antenna assembly facility brought together mtex, NRAO, German politicians, consulate diplomats, and the New Mexico State Department to unveil the new prototype ngVLA antenna structure. The week concluded with mtex and NRAO hosting local high school students who came to learn about radio astronomy, engineering processes, and careers in STEM.

In collaboration with the scientific and technical staff, and contributors across the Observatory, SciCom continued to edit and improve the Observatory's monthly digital NRAO Newsletter, and the occasional electronic announcements series, NRAO Announcements. The subscription base for the NRAO Newsletter and the Announcements stands at 9,500+ addresses. SciCom also continued to edit and publish the semi-annual CASA News in collaboration with the CASA team.

From 2021-2023, SciCom continued to edit, improve, publish, and expand the subscription base for the Observatory's monthly electronic newsletter, NRAO eNews, and the periodic electronic announcements series, NRAO Announcements, with 9,700+ subscribers in North America and around the world. SciCom also updated the NRAO Research Facilities brochure prior to the all the winter AAS conferences.

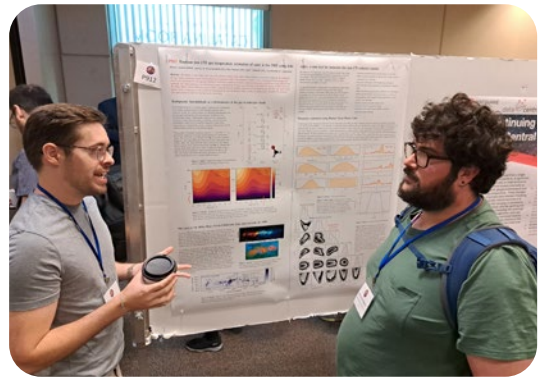

Photos by Brian R. Kent, NRAO/AUI/NSF

# PERFORMANCE METRICS

## Observing Hours

Telescope performance for the VLA and VLBA is characterized by the NRAO in the following categories: Scheduled, Maintenance, Test, Unscheduled, or Shutdown. The sum of these categories is the total number of available hours each month: 720 hours in a 30-day month, and 744 hours in a 31-day month. Scheduled science operations time is either Astronomy or Downtime.

ALMA telescope time is reported by the Joint ALMA Observatory in two categories: Observing and Other.

### Observing hours for each NRAO telescope are divided into the following categories:

#### **Scheduled: Planned hours of observing time for peer-reviewed science proposals**

Scheduled = [ Astronomy + Downtime ]

**Astronomy: Actual hours of observing time for peer-reviewed science proposals**

**Downtime: Hours lost during scheduled observing time for peer-reviewed science proposals**

**Maintenance:** Actual hours of scheduled service of infrastructure, structure, electronics, and software.

**Test:** Actual hours for test observations rather than peer-reviewed science proposals.

**Unscheduled:** Actual idle hours owing to gaps between observing programs that cannot be scheduled and to predicted, extended inclement weather.

**Shutdown:** Actual shutdown hours, usually for a holiday. Other major shutdowns occur for major equipment work.

## 2021 PERFORMANCE METRICS

ALMA Observing Hours

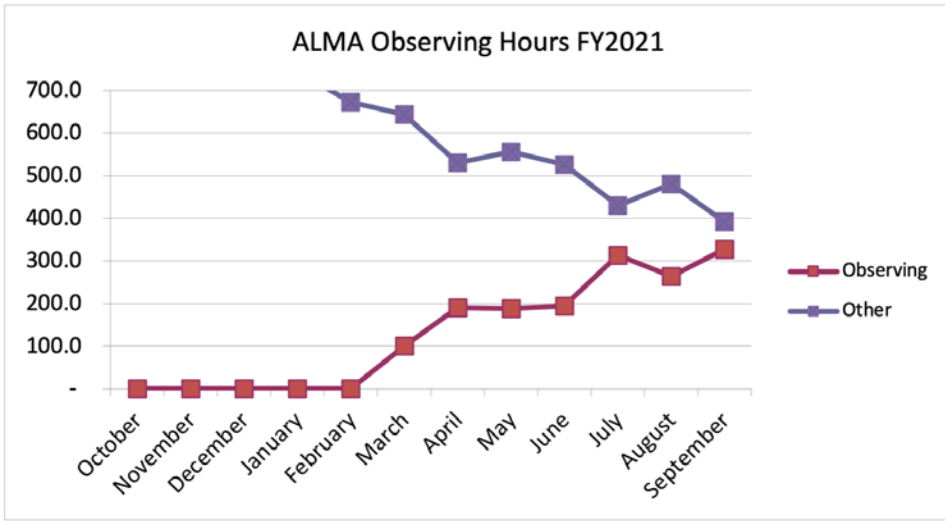

VLA Observing Hours

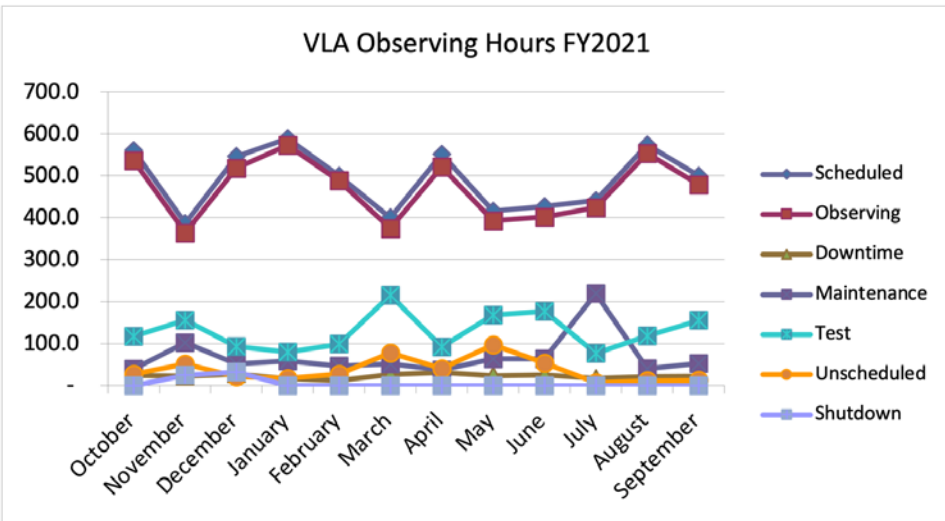

VLBA Observing Hours

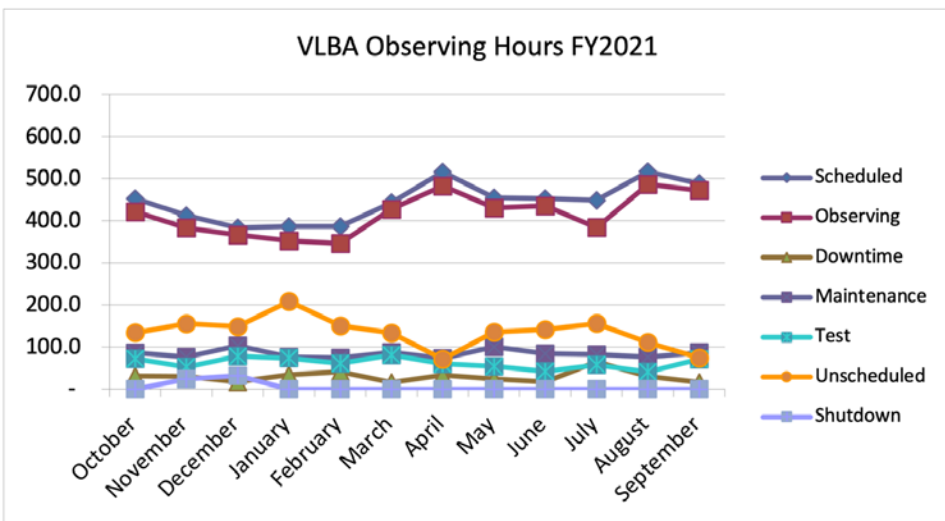

# 2021 PERFORMANCE METRICS

## Observing Hours by Science Category

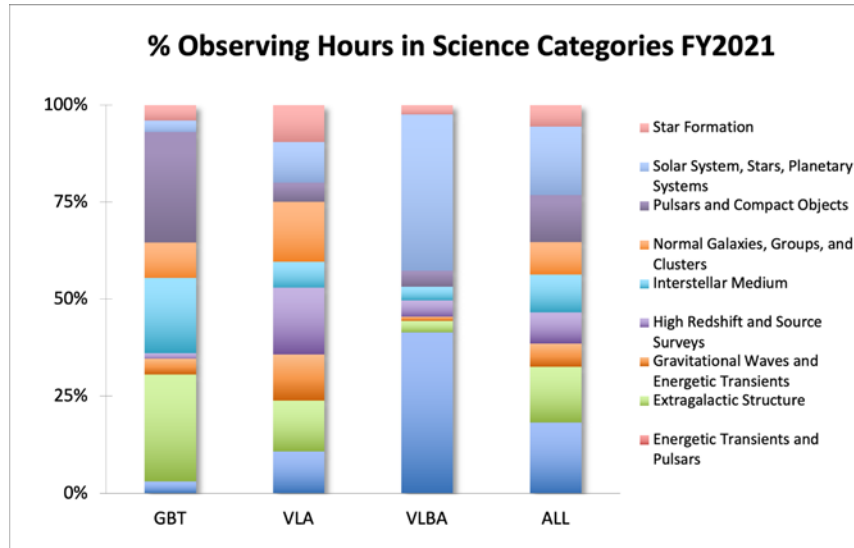

Observing hours for each of the GBT, VLA, and VLBA are tracked in the nine science categories defined in the NRAO-GBO proposal evaluation and time allocation process.





## 2022 PERFORMANCE METRICS

ALMA Observing Hours

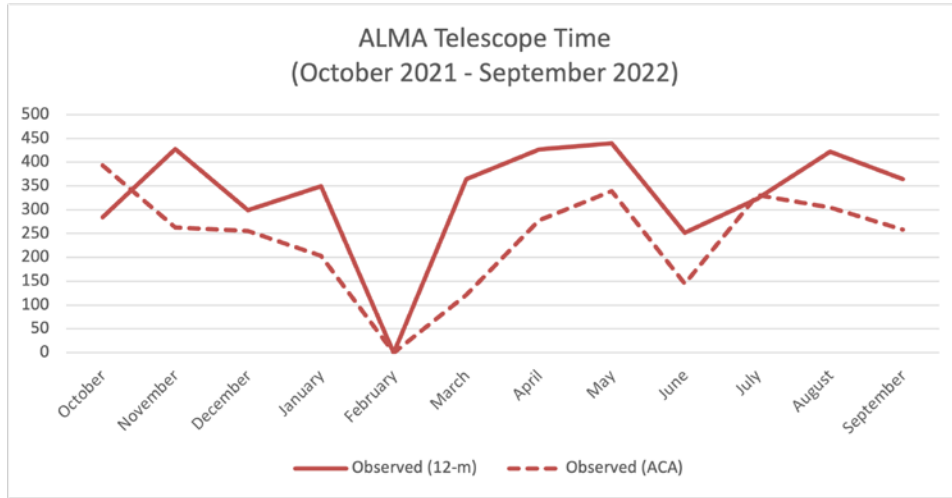

VLA Observing Hours

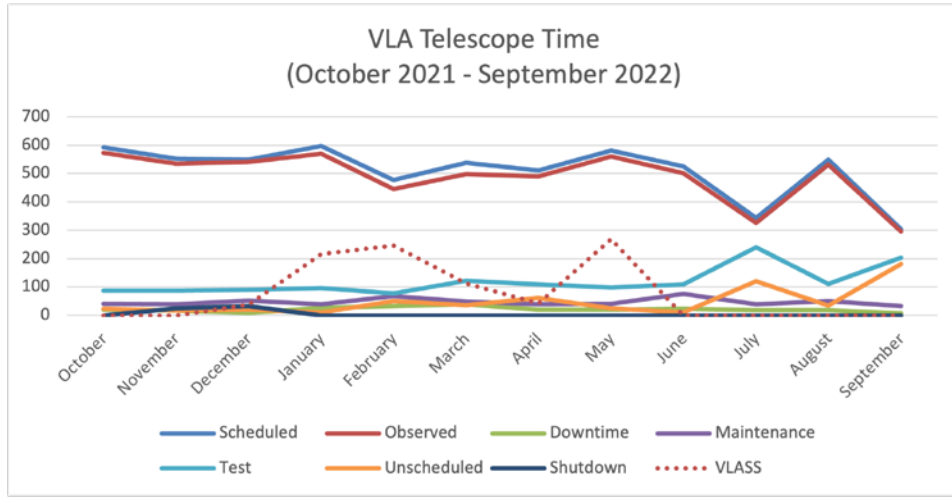

VLBA Observing Hours

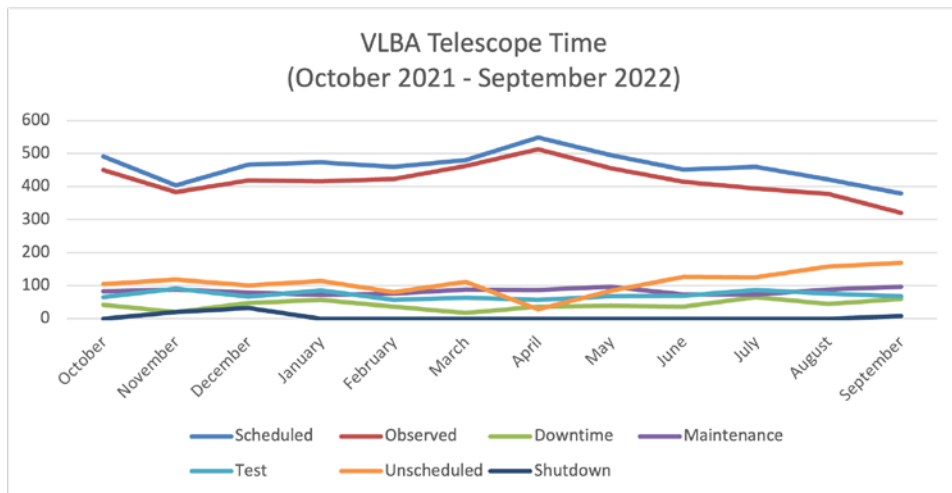

# 2022 PERFORMANCE METRICS

## Observing Hours by Science Category

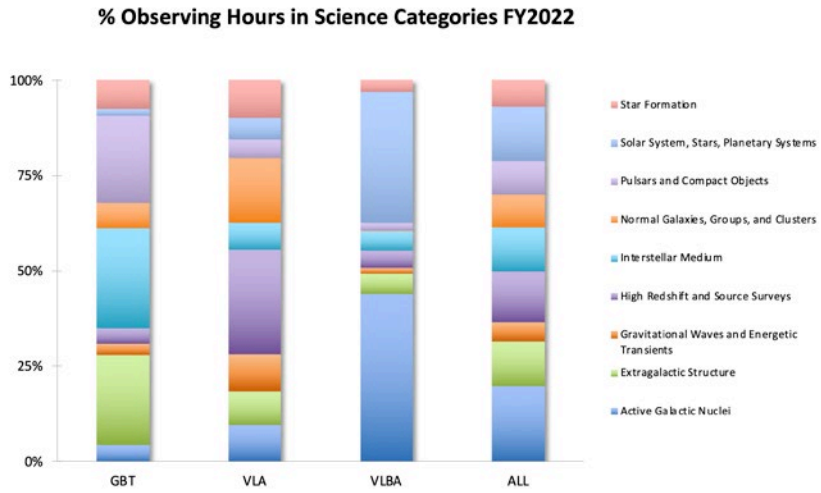

Observing hours for each of the GBT, VLA, and VLBA are tracked in the nine science categories defined in the NRAO-GBO proposal evaluation and time allocation process.



## 2023 PERFORMANCE METRICS

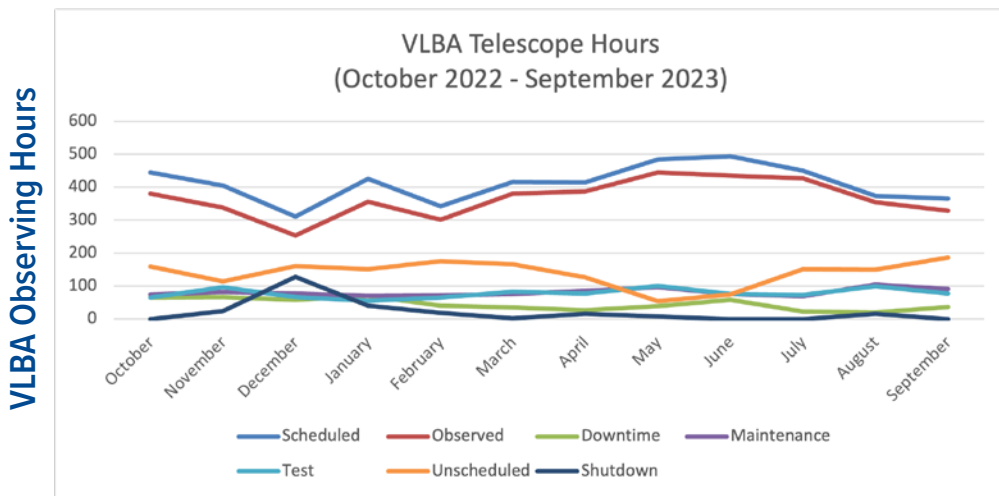
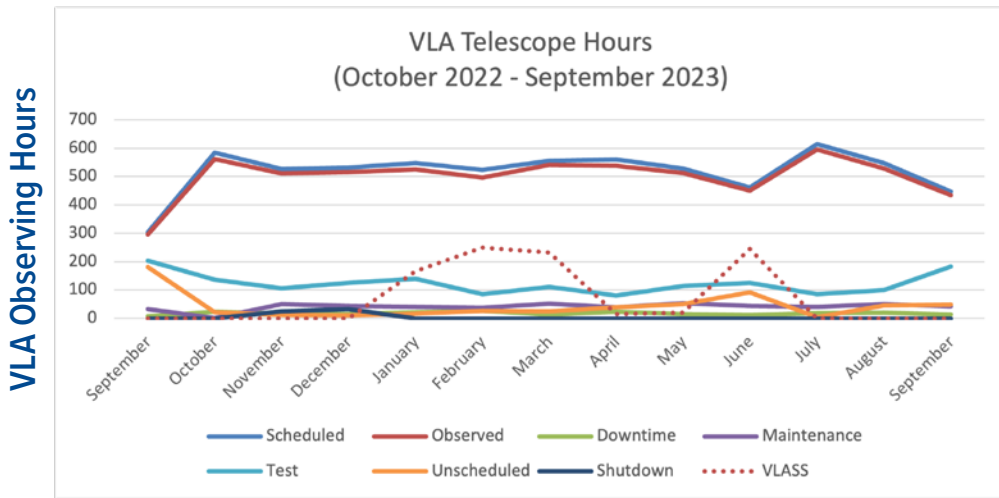
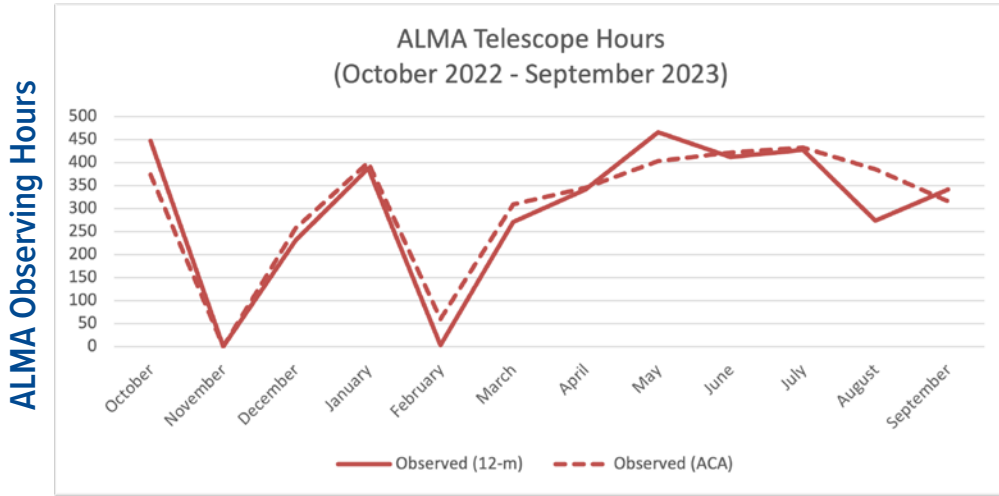

# 2023 PERFORMANCE METRICS

## Observing Hours by Science Category

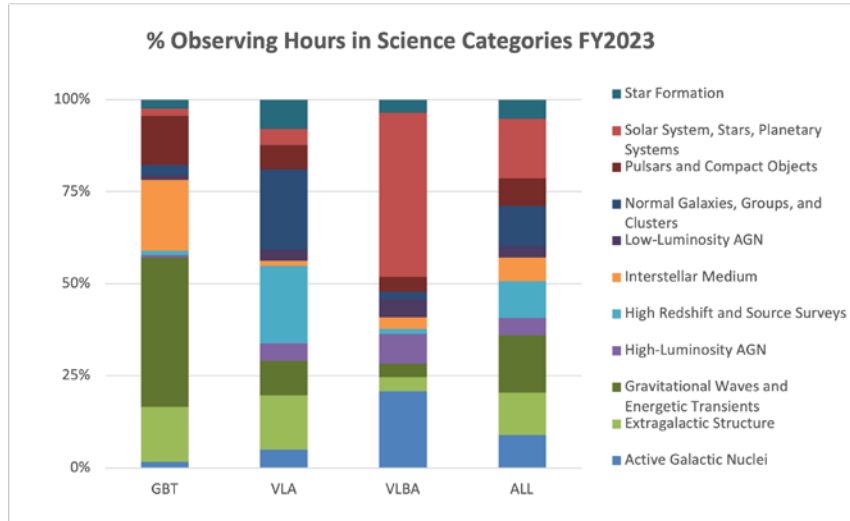

Observing hours for each of the GBT, VLA, and VLBA are tracked in the eleven science categories defined in the NRAO-GBO proposal evaluation and time allocation process.



## 2021-2023 Refereed Telescope and Author Papers

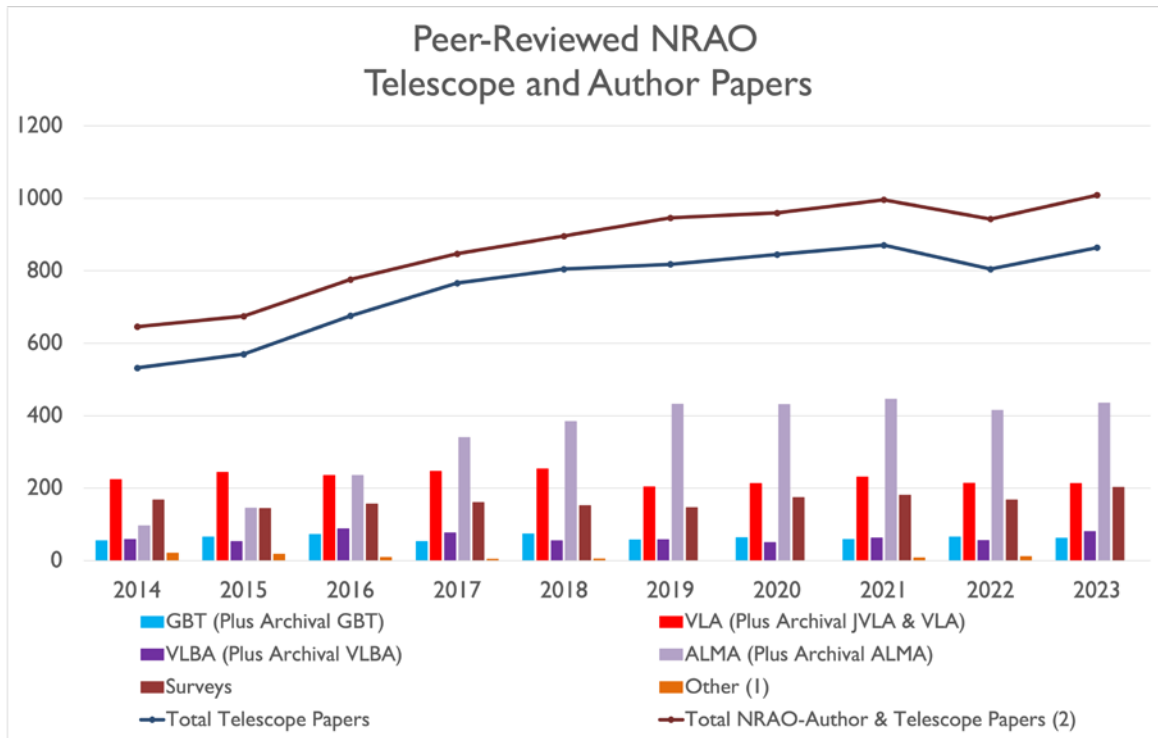

**Total Peer-Reviewed NRAO-Author and Telescope Papers:** Peer-reviewed publications that include NRAO telescope data, plus peer-reviewed publications by NRAO staff based on non-NRAO telescope data. **Total Peer-Reviewed Telescope Papers:** Peer-reviewed publications that include NRAO telescope data. **Other:** Peer-reviewed publications based on data from NRAO telescopes other than ALMA, VLA, VLBA, and GBT.

## 2023 ALMA Science Data Archive Volume

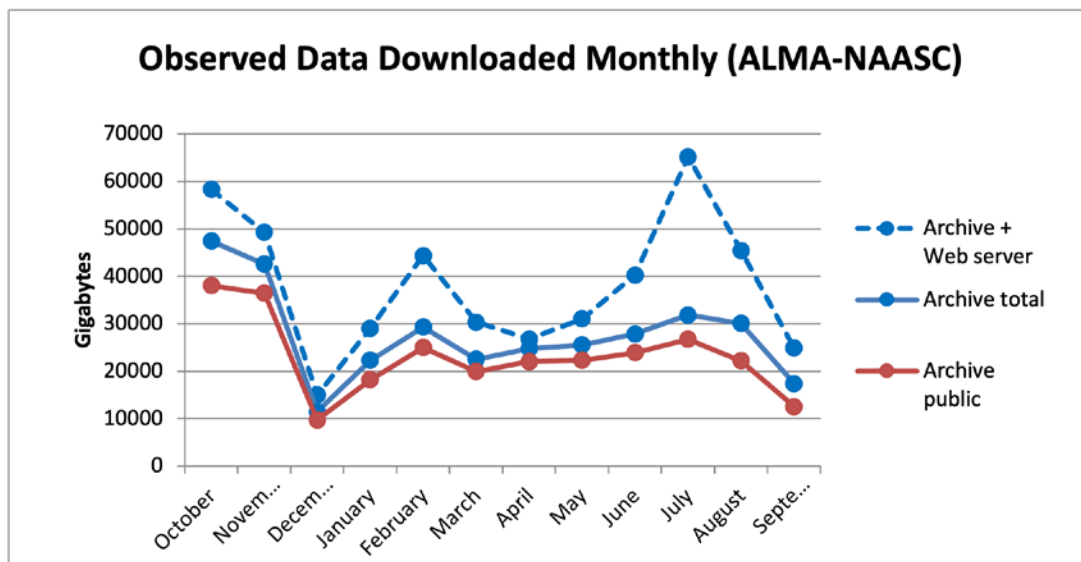

## 2021 NRAO REFEREED PUBLICATIONS

- Acciari, V. A.; Ansoldi, S.; Antonelli, L. A.; Arbet Engels, A.; Artero, M.; Asano, K.; Baack, D.; Babić, A.; Baquero, A.; Barres De Almeida, U.; Barrio, J. A.; Batković, I.; Becerra González, J.; Bednarek, W.; Bellizzi, L.; Bernardini, E.; Bernardos, M.; Berti, A.; Besenrieder, J.; Bhattacharyya, W.; Bigongiari, C.; Biland, A.; Blanch, O.; Bošnjak, Ž.; Busetto, G.; Carosi, R.; Ceribella, G.; Cerruti, M.; Chai, Y.; Chilingarian, A.; Cikota, S.; Colak, S. M.; Colombo, E.; Contreras, J. L.; Cortina, J.; Covino, S.; D'Amico, G.; D'Elia, V.; Da Vela, P.; Dazzi, F.; De Angelis, A.; De Lotto, B.; Delfino, M.; Delgado, J.; Delgado Mendez, C.; Depaoli, D.; Pierro, F. Di; Venere, L. Di; Do Souto Espiñeira, E.; Dominis Prester, D.; Donini, A.; Dorner, D.; Doro, M.; Elsaesser, D.; Fallah Ramazani, V.; Fattorini, A.; Ferrara, G.; Fonseca, M. V.; Font, L.; Fruck, C.; Fukami, S.; García López, R. J.; Garczarczyk, M.; Gasparyan, S.; Gaug, M.; Giglietto, N.; Giordano, F.; Gliwny, P.; Godinović, N.; Green, J. G.; Green, D.; Hadasch, D.; Hahn, A.; Heckmann, L.; Herrera, J.; Hoang, J.; Hrupec, D.; Hütten, M.; Inada, T.; Inoue, S.; Ishio, K.; Iwamura, Y.; Jiménez, I.; Jormanainen, J.; Jouvin, L.; Kajiwara, Y.; Karjalainen, M.; Kerszberg, D.; Kobayashi, Y.; Kubo, H.; Kushida, J.; Lamastra, A.; Lelas, D.; Leone, F.; Lindfors, E.; Lombardi, S.; Longo, F.; López-Coto, R.; López-Moya, M.; López-Oramas, A.; Loporchio, S.; Machado De Oliveira Fraga, B.; Maggio, C.; Majumdar, P.; Makariev, M.; Mallamaci, M.; Maneva, G.; Manganaro, M.; Mannheim, K.; Maraschi, L.; Mariotti, M.; Martínez, M.; Mazin, D.; Menchiari, S.; Mender, S.; Mićanović, S.; Miceli, D.; Miener, T.; Minev, M.; Miranda, J. M.; Mirzoyan, R.; Molina, E.; Moralejo, A.; Morcuende, D.; Moreno, V.; Moretti, E.; Neustroev, V.; Nigro, C.; Nilsson, K.; Nishijima, K.; Noda, K.; Nozaki, S.; Ohtani, Y.; Oka, T.; Otero-Santos, J.; Palatiello, M.; Paneque, D.; Paoletti, R.; Paredes, J. M.; Pavletić, L.; Peñil, P.; Perennes, C.; Persic, M.; Prada Moroni, P. G.; Prandini, E.; Priyadarshi, C.; Puljak, I.; Rhode, W.; Ribó, M.; Rico, J.; Righi, C.; Rugliancich, A.; Saha, L.; Sahakyan, N.; Saito, T.; Sakurai, S.; Satalecka, K.; Schleicher, B.; Schmidt, K.; Schweizer, T.; Sitarek, J.; Šnidarić, I.; Sobczynska, D.; Spolon, A.; Stammer, A.; Strom, D.; Strzys, M.; Suda, Y.; Surić, T.; Takahashi, M.; Tavecchio, F.; Temnikov, P.; Terzić, T.; Teshima, M.; Torres-Albà, N.; Tosti, L.; Truzzi, S.; Van Scherpenberg, J.; Vanzo, G.; Vazquez Acosta, M.; Ventura, S.; Verguilo, V.; Vigorito, C. F.; Vitale, V.; Vovk, I.; Will, M.; Zarić, D.; Arbet-Engels, A.; Baack, D.; Balbo, M.; Beck, M.; Biederbeck, N.; Biland, A.; Bretz, T.; Bruegge, K.; Buss, J.; Dorner, D.; Elsaesser, D.; Hildebrand, D.; Iotov, R.; Klinger, M.; Mannheim, K.; Neise, D.; Neronov, A.; Noethe, M.; Paravac, A.; Rhode, W.; Schleicher, B.; Sliusar, V.; Theissen, F.; Walter, R.; Valverde, J.; Horan, D.; Giroletti, M.; Perri, M.; Verrecchia, F.; Leto, C.; Sadun, A. C.; Moody, J. W.; Joner, M.; Marscher, A. P.; Jorstad, S. G.; Lähteenmäki, A.; Tornikoski, M.; Ramakrishnan, V.; Järvelä, E.; Vera, R. J. C.; Righini, S.; Lien, A. Y. "Multiwavelength variability and correlation studies of Mrk 421 during historically low X-ray and  $\gamma$ -ray activity in 2015-2016" *Monthly Notices of the Royal Astronomical Society*, 504 :1427, 2021.
- Agar, C. H.; Weltevrede, P.; Bondonneau, L.; Griebmeier, J.-M.; Hessels, J. W. T.; Huang, W. J.; Karastergiou, A.; Keith, M. J.; Kondratiev, V. I.; Künsemöller, J.; Li, D.; Peng, B.; Sobey, C.; Stappers, B. W.; Tan, C. M.; Theureau, G.; Wang, H. G.; Zhang, C. M.; Ceccconi, B.; Girard, J. N.; Loh, A.; Zarka, P. "A broad-band radio study of PSR J0250+5854: the slowest spinning radio pulsar known" *Monthly Notices of the Royal Astronomical Society*, 508 :1102, 2021.
- Agazie, G. Y.; Mingyar, M. G.; Mclaughlin, M. A.; Swiggum, J. K.; Kaplan, D. L.; Blumer, H.; Chawla, P.; Decesar, M.; Demorest, P. B.; Fiore, W.; Fonseca, E.; Gelfand, J. D.; Kaspi, V. M.; Kondratiev, V. I.; Larose, M.; Van Leeuwen, J.; Levin, L.; Lewis, E. F.; Lynch, R. S.; McEwen, A. E.; Al Noori, H.; Parent, E.; Ransom, S. M.; Roberts, M. S. E.; Schmiedekamp, A.; Schmiedekamp, C.; Siemens, X.; Spiewak, R.; Stairs, I. H.; Surnis, M. "The Green Bank Northern Celestial Cap Pulsar Survey. VI. Discovery and Timing of PSR J1759+5036: A Double Neutron Star Binary Pulsar" *The Astrophysical Journal*, 922 :35, 2021.
- Aggarwal, Kshitij; Burke-Spolaor, Sarah; Law, Casey J.; Bower, Geoffrey C.; Butler, Bryan J.; Demorest, Paul B.; Lazio, T. Joseph W.; Linford, Justin; Sydnor, Jessica; Anna-Thomas, Reshma "Robust Assessment of Clustering Methods for Fast Radio Transient Candidates" *The Astrophysical Journal*, 914 :53, 2021.
- Aggarwal, Kshitij; Burke-Spolaor, Sarah; Tejos, Nicolas; Pignata, Giuliano; Xavier Prochaska, J.; Ravi, Vikram; Kaczmarek, Jane F.; Osłowski, Stefan "Multiwavelength Follow-up of FRB180309" *The Astrophysical Journal*, 913 :78, 2021.
- Agliozzo, C.; Phillips, N.; Mehner, A.; Baade, D.; Scicluna, P.; Kemper, F.; Asmus, D.; De Wit, W.-J.; Pignata, G. "The contribution by luminous blue variable stars to the dust content of the Magellanic Clouds" *Astronomy and Astrophysics*, 655 :A98, 2021.
- Ahumada, Tomás; Singer, Leo P.; Anand, Shreya; Coughlin, Michael W.; Kasliwal, Mansi M.; Ryan, Geoffrey; Andreoni, Igor; Cenko, S. Bradley; Fremming, Christoffer; Kumar, Harsh; Pang, Peter T. H.; Burns, Eric; Cunningham, Virginia; Dichiaro, Simone; Dietrich, Tim; Svinik, Dmitry S.; Almualla, Mouza; Castro-Tirado, Alberto J.; De, Kishalay; Dunwoody, Rachel; Gatkine, Pradip; Hammerstein, Erica; Ilyani, Shabnam; Mangan, Joseph; Perley, Dan; Purkayastha, Sonalika;
- Acciari, V. A.; Ansoldi, S.; Antonelli, L. A.; Asano, K.; Babić, A.; Banerjee, B.; Baquero, A.; De Almeida, U.; Barres; Barrio, J. A.; Becerra González, J.; Bednarek, W.; Bellizzi, L.; Bernardini, E.; Bernardos, M.; Berti, A.; Besenrieder, J.; Bhattacharyya, W.; Bigongiari, C.; Blanch, O.; Bonnoli, G.; Bošnjak, Ž.; Busetto, G.; Carosi, R.; Ceribella, G.; Cerruti, M.; Chai, Y.; Chilingarian, A.; Cikota, S.; Colak, S. M.; Colombo, E.; Contreras, J. L.; Cortina, J.; Covino, S.; D'Amico, G.; D'Elia, V.; Da Vela, P.; Dazzi, F.; De Angelis, A.; De Lotto, B.; Delfino, M.; Delgado, J.; Delgado Mendez, C.; Depaoli, D.; Di Girolamo, T.; Di Pierro, F.; Di Venere, L.; Do Souto Espiñeira, E.; Dominis Prester, D.; Donini, A.; Doro, M.; Fallah Ramazani, V.; Fattorini, A.; Ferrara, G.; Foffano, L.; Fonseca, M. V.; Font, L.; Fruck, C.; Fukami, S.; García López, R. J.; Garczarczyk, M.; Gasparyan, S.; Gaug, M.; Giglietto, N.; Giordano, F.; Gliwny, P.; Godinović, N.; Green, J. G.; Green, D.; Hadasch, D.; Hahn, A.; Heckmann, L.; Herrera, J.; Hoang, J.; Hrupec, D.; Hütten, M.; Inada, T.; Inoue, S.; Ishio, K.; Iwamura, Y.; Jormanainen, J.; Jouvin, L.; Kajiwara, Y.; Karjalainen, M.; Kerszberg, D.; Kobayashi, Y.; Kubo, H.; Kushida, J.; Lamastra, A.; Lelas, D.; Leone, F.; Lindfors, E.; Lombardi, S.; Longo, F.; López, M.; López-Coto, R.; López-Oramas, A.; Loporchio, S.; Machado De Oliveira Fraga, B.; Maggio, C.; Majumdar, P.; Makariev, M.; Mallamaci, M.; Maneva, G.; Manganaro,

- Bellm, Eric; Bhalerao, Varun; Bolin, Bryce; Bulla, Mattia; Cannella, Christopher; Chandra, Poonam; Duev, Dmitry A.; Frederiks, Dmitry; Gal-Yam, Avishay; Graham, Matthew; Ho, Anna Y. Q.; Hurley, Kevin; Karmelkar, Viraj; Kool, Erik C.; Kulkarni, S. R.; Mahabal, Ashish; Masci, Frank; MCBreen, Sheila; Pandey, Shashi B.; Reusch, Simeon; Ridnaia, Anna; Rosnet, Philippe; Rusholme, Benjamin; Carracedo, Ana Sagués; Smith, Roger; Soumagnac, Maayane; Stein, Robert; Troja, Eleonora; Tsvetkova, Anastasia; Walters, Richard; Valeev, Azamat F. "Discovery and confirmation of the shortest gamma-ray burst from a collapsar" *Nature Astronomy*, 5 :917, 2021.
- Aikawa, Yuri; Cataldi, Gianni; Yamato, Yoshihide; Zhang, Ke; Booth, Alice S.; Furuya, Kenji; Andrews, Sean M.; Bae, Jaehan; Bergin, Edwin A.; Bergner, Jennifer B.; Bosman, Arthur D.; Cleeves, L. Ilse; Czekala, Ian; Guzmán, Viviana V.; Huang, Jane; Ilee, John D.; Law, Charles J.; Le Gal, Romane; Loomis, Ryan A.; Ménard, François; Nomura, Hideko; Öberg, Karin I.; Qi, Chunhua; Schwarz, Kamber R.; Teague, Richard; Tsukagoshi, Takashi; Walsh, Catherine; Wilner, David J. "Molecules with ALMA at Planet-forming Scales (MAPS). XIII. HCO<sup>+</sup> and Disk Ionization Structure" *The Astrophysical Journal Supplement Series*, 257 :13, 2021.
- Akeson, Rachel; Beichman, Charles; Kervella, Pierre; Fomalont, Edward; Benedict, G. Fritz "Precision Millimeter Astrometry of the  $\alpha$  Centauri AB System" *The Astronomical Journal*, 162 :14, 2021.
- Akins, Alex B.; Lincowski, Andrew P.; Meadows, Victoria S.; Steffes, Paul G. "Complications in the ALMA Detection of Phosphine at Venus" *The Astrophysical Journal*, 907 :L27, 2021.
- Al Yazeedi, Aisha; Katkov, Ivan Yu.; Gelfand, Joseph D.; Wylezalek, Dominika; Zakamska, Nadia L.; Liu, Weizhe "The Impact of Low-luminosity AGNs on Their Host Galaxies: A Radio and Optical Investigation of the Kiloparsec-scale Outflow in MaNGA 1-166919" *The Astrophysical Journal*, 916 :102, 2021.
- Alam, Md F.; Arzoumanian, Zaven; Baker, Paul T.; Blumer, Harsha; Bohler, Keith E.; Brazier, Adam; Brook, Paul R.; Burke-Spolaor, Sarah; Caballero, Keeisi; Camuccio, Richard S.; Chamberlain, Rachel L.; Chatterjee, Shami; Cordes, James M.; Cornish, Neil J.; Crawford, Fronefield; Cromartie, H. Thankful; Decesar, Megan E.; Demorest, Paul B.; Dolch, Timothy; Ellis, Justin A.; Ferdman, Robert D.; Ferrara, Elizabeth C.; Fiore, William; Fonseca, Emmanuel; Garcia, Yhamil; Garver-Daniels, Nathan; Gentile, Peter A.; Good, Deborah C.; Gusdorff, Jordan A.; Halmrast, Daniel; Hazboun, Jeffrey S.; Islo, Kristina; Jennings, Ross J.; Jessup, Cody; Jones, Megan L.; Kaiser, Andrew R.; Kaplan, David L.; Kelley, Luke Zoltan; Key, Joey Shapiro; Lam, Michael T.; Lazio, T. Joseph W.; Lorimer, Duncan R.; Luo, Jing; Lynch, Ryan S.; Madison, Dustin R.; Maraccini, Kaleb; Mclaughlin, Maura A.; Mingarelli, Chiara M. F.; Ng, Cherry; Nguyen, Benjamin M. X.; Nice, David J.; Pennucci, Timothy T.; Pol, Nihan S.; Ramette, Joshua; Ransom, Scott M.; Ray, Paul S.; Shapiro-Albert, Brent J.; Siemens, Xavier; Simon, Joseph; Spiewak, René; Stairs, Ingrid H.; Stinebring, Daniel R.; Stovall, Kevin; Swiggum, Joseph K.; Taylor, Stephen R.; Tripepi, Michael; Vallisneri, Michele; Vigeland, Sarah J.; Witt, Caitlin A.; Zhu, Weiwei; Nanograv Collaboration "The NANOGrav 12.5 yr Data Set: Observations and Narrowband Timing of 47 Millisecond Pulsars" *The Astrophysical Journal Supplement Series*, 252 :4, 2021.
- Alam, Md F.; Arzoumanian, Zaven; Baker, Paul T.; Blumer, Harsha; Bohler, Keith E.; Brazier, Adam; Brook, Paul R.; Burke-Spolaor, Sarah; Caballero, Keeisi; Camuccio, Richard S.; Chamberlain, Rachel L.; Chatterjee, Shami; Cordes, James M.; Cornish, Neil J.; Crawford, Fronefield; Cromartie, H. Thankful; Decesar, Megan E.; Demorest, Paul B.; Dolch, Timothy; Ellis, Justin A.; Ferdman, Robert D.; Ferrara, Elizabeth C.; Fiore, William; Fonseca, Emmanuel; Garcia, Yhamil; Garver-Daniels, Nathan; Gentile, Peter A.; Good, Deborah C.; Gusdorff, Jordan A.; Halmrast, Daniel; Hazboun, Jeffrey S.; Islo, Kristina; Jennings, Ross J.; Jessup, Cody; Jones, Megan L.; Kaiser, Andrew R.; Kaplan, David L.; Kelley, Luke Zoltan; Key, Joey Shapiro; Lam, Michael T.; Lazio, T. Joseph W.; Lorimer, Duncan R.; Luo, Jing; Lynch, Ryan S.; Madison, Dustin R.; Maraccini, Kaleb; Mclaughlin, Maura A.; Mingarelli, Chiara M. F.; Ng, Cherry; Nguyen, Benjamin M. X.; Nice, David J.; Pennucci, Timothy T.; Pol, Nihan S.; Ramette, Joshua; Ransom, Scott M.; Ray, Paul S.; Shapiro-Albert, Brent J.; Siemens, Xavier; Simon, Joseph; Spiewak, René; Stairs, Ingrid H.; Stinebring, Daniel R.; Stovall, Kevin; Swiggum, Joseph K.; Taylor, Stephen R.; Tripepi, Michael; Vallisneri, Michele; Vigeland, Sarah J.; Witt, Caitlin A.; Zhu, Weiwei; Nanograv Collaboration "The NANOGrav 12.5 yr Data Set: Wideband Timing of 47 Millisecond Pulsars" *The Astrophysical Journal Supplement Series*, 252 :5, 2021.
- Alarcón, Felipe; Bosman, Arthur D.; Bergin, Edwin A.; Zhang, Ke; Teague, Richard; Bae, Jaehan; Aikawa, Yuri; Andrews, Sean M.; Booth, Alice S.; Calahan, Jenny K.; Cataldi, Gianni; Czekala, Ian; Huang, Jane; Ilee, John D.; Law, Charles J.; Le Gal, Romane; Liu, Yao; Long, Feng; Loomis, Ryan A.; Ménard, François; Öberg, Karin I.; Schwarz, Kamber R.; Van'T Hoff, Merel L. R.; Walsh, Catherine; Wilner, David J. "Molecules with ALMA at Planet-forming Scales (MAPS). VIII. CO Gap in AS 209-Gas Depletion or Chemical Processing?" *The Astrophysical Journal Supplement Series*, 257 :8, 2021.
- Alexander, K. D.; Schroeder, G.; Paterson, K.; Fong, W.; Cowperthwaite, P.; Gomez, S.; Margalit, B.; Margutti, R.; Berger, E.; Blanchard, P.; Chornock, R.; Eftekhari, T.; Laskar, T.; Metzger, B. D.; Nicholl, M.; Villar, V. A.; Williams, P. K. G. "A Late-time Galaxy-targeted Search for the Radio Counterpart of GW190814" *The Astrophysical Journal*, 923 :66, 2021.
- Algera, H. S. B.; Hodge, J. A.; Riechers, D.; Murphy, E. J.; Pavesi, R.; Aravena, M.; Daddi, E.; Decarli, R.; Dickinson, M.; Sargent, M.; Sharon, C. E.; Wagg, J. "COLDz: Deep 34 GHz Continuum Observations and Free-Free Emission in High-redshift Star-forming Galaxies" *The Astrophysical Journal*, 912 :73, 2021.
- Alonso, E. R.; Kolesníková, L.; Belloche, A.; Mata, S.; Garrod, R. T.; Jabri, A.; León, I.; Guillemin, J.-C.; Müller, H. S. P.; Menten, K. M.; Alonso, J. L. "Rotational spectroscopic study and astronomical search for propiolamide in Sgr B2(N)" *Astronomy and Astrophysics*, 647 :A55, 2021.
- Alonso-Herrero, A.; García-Burillo, S.; Hönig, S. F.; García-Bernete, I.; Ramos Almeida, C.; González-Martín, O.; López-Rodríguez, E.; Boorman, P. G.; Bunker, A. J.; Burtscher, L.; Combes, F.; Davies, R.; Díaz-Santos, T.; Gandhi, P.; García-Lorenzo, B.; Hicks, E. K. S.; Hunt, L. K.; Ichikawa, K.; Imanishi, M.; Izumi, T.; Labiano, A.; Levenson, N. A.; Packham, C.; Pereira-Santaella, M.; Ricci, C.; Rigopoulou, D.; Roche, P.; Rosario, D. J.; Rouan, D.; Shimizu, T.; Stalevski, M.; Wada, K.; Williamson, D. "The Galaxy Activity, Torus, and Outflow Survey (GATOS). II. Torus and polar dust emission in nearby Seyfert galaxies" *Astronomy and Astrophysics*, 652 :A99, 2021.
- Amaral, A. D.; Vernstrom, T.; Gaensler, B. M. "Constraints on large-scale magnetic fields in the intergalactic medium using cross-correlation methods" *Monthly Notices of the Royal Astronomical Society*, 503 :2913, 2021.
- An, Fangxia; Vaccari, M.; Smail, Ian; Jarvis, M. J.; Whittam, I. H.; Hale, C. L.; Jin, S.; Collier, J. D.; Daddi, E.; Delhaize, J.; Frank, B.; Murphy, E. J.; Prescott, M.; Sekhar, S.; Taylor, A. R.; Ao, Y.; Knowles, K.; Marchetti, L.; Randriamampandry, S. M.; Randriamanakoto, Z. "Radio spectral properties of star-forming galaxies in the MIGHTEE-COSMOS field and their impact on the far-infrared-radio correlation" *Monthly Notices of the Royal Astronomical Society*, 507 :2643, 2021.
- Andernach, Heinz; Jiménez-Andrade, Eric F.; Willis, Anthony G. "Discovery of 178 Giant Radio Galaxies in 1059 deg<sup>2</sup> of the Rapid ASKAP Continuum Survey at 888 MHz" *Galaxies*, 9 :99, 2021.
- Anderson, C. S.; Heald, G. H.; Eilek, J. A.; Lenc, E.; Gaensler, B. M.; Rudnick, Lawrence; Van Eck, C. L.; O'Sullivan, S. P.; Stil, J. M.; Chippendale, A.; Riseley, C. J.; Carretti, E.; West, J.; Farnes, J.; Harvey-Smith, L.; McClure-Griffiths, N. M.; Bock, Douglas C. J.; Bunton, J. D.; Koribalski, B.; Tremblay, C. D.; Voronkov, M. A.; Warhurst, K. "Early Science from POSSUM: Shocks, turbulence, and a massive new reservoir of ionised

## APPENDIX A: PUBLICATIONS

- gas in the Fornax cluster" *Publications of the Astronomical Society of Australia*, 38 :e020, 2021.
- Anderson, L. D.; Luisi, Matteo; Liu, Bin; Wenger, Trey V.; Balsaer, Dana. S.; Bania, T. M.; Haffner, L. M.; Linville, Dylan J.; Mascoop, J. L. "The GBT Diffuse Ionized Gas Survey (DIGS): Survey Overview and First Data Release" *The Astrophysical Journal Supplement Series*, 254 :28, 2021.
- Anderson, Michael; Peretto, Nicolas; Ragan, Sarah E.; Rigby, Andrew J.; Avison, Adam; Duarte-Cabral, Ana; Fuller, Gary A.; Shirley, Yancy L.; Traficante, Alessio; Williams, Gwenllian M. "An ALMA study of hub-filament systems - I. On the clump mass concentration within the most massive cores" *Monthly Notices of the Royal Astronomical Society*, 508 :2964, 2021.
- Andreon, S.; Romero, C.; Castagna, F.; Ragagnin, A.; Devlin, M.; Dicker, S.; Mason, B.; Mroczkowski, T.; Sarazin, C.; Sievers, J.; Stanchfield, S. "Thermodynamic evolution of the  $z = 1.75$  galaxy cluster IDCS J1426.5+3508" *Monthly Notices of the Royal Astronomical Society*, 505 :5896, 2021.
- Andrews, Sean M.; Elder, William; Zhang, Shangjia; Huang, Jane; Benisty, Myriam; Kurtovic, Nicolás T.; Wilner, David J.; Zhu, Zhaohuan; Carpenter, John M.; Pérez, Laura M.; Teague, Richard; Isella, Andrea; Ricci, Luca "Limits on Millimeter Continuum Emission from Circumplanetary Material in the DSHARP Disks" *The Astrophysical Journal*, 916 :51, 2021.
- Andriantaralaza, M.; Ramstedt, S.; Vlemmings, W. H. T.; Danilovich, T.; De Beck, E.; Groenewegen, M. A. T.; Höfner, S.; Kerschbaum, F.; Khouri, T.; Lindqvist, M.; Maercker, M.; Olofsson, H.; Quintana-Lacaci, G.; Saberi, M.; Sahai, R.; Zijlstra, A. "DEATHSTAR: nearby AGB stars with the Atacama Compact Array. II. CO envelope sizes and asymmetries: the S-type stars" *Astronomy and Astrophysics*, 653 :A53, 2021.
- Armentrout, W. P.; Anderson, L. D.; Wenger, Trey V.; Balsaer, Dana S.; Bania, T. M. "A VLA Census of the Galactic H II Region Population" *The Astrophysical Journal Supplement Series*, 253 :23, 2021.
- Arras, Philipp; Bester, Hertzog L.; Perley, Richard A.; Leike, Reimar; Smirnov, Oleg; Westermann, Rüdiger; Enßlin, Torsten A. "Comparison of classical and Bayesian imaging in radio interferometry. Cygnus A with CLEAN and resolve" *Astronomy and Astrophysics*, 646 :A84, 2021.
- Arzoumanian, D.; Furuya, R. S.; Hasegawa, T.; Tahani, M.; Sadavoy, S.; Hull, C. L. H.; Johnstone, D.; Koch, P. M.; Inutsuka, S.; Doi, Y.; Hoang, T.; Onaka, T.; Iwasaki, K.; Shimajiri, Y.; Inoue, T.; Peretto, N.; André, P.; Bastien, P.; Berry, D.; Chen, H.-R. V.; Di Francesco, J.; Eswarajah, C.; Fanciullo, L.; Fissel, L. M.; Hwang, J.; Kang, J. -H.; Kim, G.; Kim, K.-T.; Kirchschrager, F.; Kwon, W.; Lee, C. W.; Liu, H.-L.; Lyo, A.-R.; Pattle, K.; Soam, A.; Tang, X.; Whitworth, A.; Ching, T.-C.; Coudé, S.; Wang, J.-W.; Ward-Thompson, D.; Lai, S.-P.; Qiu, K.; Bourke, T. L.; Byun, D.-Y.; Chen, M.; Chen, Z.; Chen, W. P.; Cho, J.; Choi, Y.; Choi, M.; Chrysostomou, A.; Chung, E. J.; Dai, S.; Diep, P. N.; Duan, H.-Y.; Duan, Y.; Eden, D.; Fiege, J.; Franzmann, E.; Friberg, P.; Fuller, G.; Gledhill, T.; Graves, S.; Greaves, J.; Griffin, M.; Gu, Q.; Han, I.; Hatchell, J.; Hayashi, S.; Houde, M.; Jeong, I.-G.; Kang, M.; Kang, S. -J.; Kataoka, A.; Kawabata, K.; Kemper, F.; Kim, M.-R.; Kim, K. H.; Kim, S.; Kirk, J.; Kobayashi, M. I. N.; Könyves, V.; Kusune, T.; Kwon, J.; Lacaille, K.; Law, C.-Y.; Lee, C.-F.; Lee, Y.-H.; Lee, S.-S.; Lee, H.; Lee, J.-E.; Li, H. -B.; Li, D.; Li, D. L.; Liu, J.; Liu, T.; Liu, S.-Y.; Lu, X.; Mairs, S.; Matsumura, M.; Matthews, B.; Moriarty-Schieven, G.; Nagata, T.; Nakamura, F.; Nakanishi, H.; Ngoc, N. B.; Ohashi, N.; Park, G.; Parsons, H.; Pyo, T.-S.; Qian, L.; Rao, R.; Rawlings, J.; Rawlings, M.; Retter, B.; Richer, J.; Rigby, A.; Saito, H.; Savini, G.; Scaife, A.; Seta, M.; Shinnaga, H.; Tamura, M.; Tang, Y.-W.; Tomisaka, K.; Tram, L. N.; Tsukamoto, Y.; Viti, S.; Wang, H.; Xie, J.; Yen, H.-W.; Yoo, H.; Yuan, J.; Yun, H.-S.; Zenko, T.; Zhang, G.; Zhang, C.-P.; Zhang, Y.; Zhou, J.; Zhu, L.; De Looze, I.; Dowell, C. D.; Eyres, S.; Falle, S.; Friesen, R.; Robitaille, J.-F.; Van Loo, S. "Dust polarized emission observations of NGC 6334. BISTRO reveals the details of the complex but organized magnetic field structure of the high-mass star-forming hub-filament network" *Astronomy and Astrophysics*, 647 :A78, 2021.
- Arzoumanian, Zaven; Baker, Paul T.; Blumer, Harsha; Bécsy, Bence; Brazier, Adam; Brook, Paul R.; Burke-Spolaor, Sarah; Charisi, Maria; Chatterjee, Shami; Chen, Siyuan; Cordes, James M.; Cornish, Neil J.; Crawford, Fronefield; Cromartie, H. Thankful; Decesar, Megan E.; Degan, Dallas M.; Demorest, Paul B.; Dolch, Timothy; Drachler, Brendan; Ellis, Justin A.; Ferrara, Elizabeth C.; Fiore, William; Fonseca, Emmanuel; Garver-Daniels, Nathan; Gentile, Peter A.; Good, Deborah C.; Hazboun, Jeffrey S.; Holgado, A. Miguel; Islo, Kristina; Jennings, Ross J.; Jones, Megan L.; Kaiser, Andrew R.; Kaplan, David L.; Kelley, Luke Zoltan; Key, Joey Shapiro; Laal, Nima; Lam, Michael T.; W. Lazio, T. Joseph; Lorimer, Duncan R.; Luo, Jing; Lynch, Ryan S.; Madison, Dustin R.; Mcewen, Alexander; Mclaughlin, Maura A.; Mingarelli, Chiara M. F.; Ng, Cherry; Nice, David J.; Olum, Ken D.; Pennucci, Timothy T.; Pol, Nihan S.; Ransom, Scott M.; Ray, Paul S.; Romano, Joseph D.; Sardesai, Shashwat C.; Shapiro-Albert, Brent J.; Siemens, Xavier; Simon, Joseph; Siwak, Magdalena S.; Spiwak, Renée; Stairs, Ingrid H.; Stinebring, Daniel R.; Stovall, Kevin; Sun, Jerry P.; Swiggum, Joseph K.; Taylor, Stephen R.; Turner, Jacob E.; Vallisneri, Michele; Vigeland, Sarah J.; Wahl, Haley M.; Witt, Caitlin A.; Nanograv Collaboration "The NANOGrav 12.5-year Data Set: Search for Non-Einsteinian Polarization Modes in the Gravitational-wave Background" *The Astrophysical Journal*, 923 :L22, 2021.
- Arzoumanian, Zaven; Baker, Paul T.; Blumer, Harsha; Bécsy, Bence; Brazier, Adam; Brook, Paul R.; Burke-Spolaor, Sarah; Charisi, Maria; Chatterjee, Shami; Chen, Siyuan; Cordes, James M.; Cornish, Neil J.; Crawford, Fronefield; Cromartie, H. Thankful; Decesar, Megan E.; Demorest, Paul B.; Dolch, Timothy; Ellis, Justin A.; Ferrara, Elizabeth C.; Fiore, William; Fonseca, Emmanuel; Garver-Daniels, Nathan; Gentile, Peter A.; Good, Deborah C.; Hazboun, Jeffrey S.; Holgado, A. Miguel; Islo, Kristina; Jennings, Ross J.; Jones, Megan L.; Kaiser, Andrew R.; Kaplan, David L.; Kelley, Luke Zoltan; Key, Joey Shapiro; Laal, Nima; Lam, Michael T.; Lazio, T. Joseph W.; Lee, Vincent S. H.; Lorimer, Duncan R.; Luo, Jing; Lynch, Ryan S.; Madison, Dustin R.; Mclaughlin, Maura A.; Mingarelli, Chiara M. F.; Mitridate, Andrea; Ng, Cherry; Nice, David J.; Pennucci, Timothy T.; Pol, Nihan S.; Ransom, Scott M.; Ray, Paul S.; Shapiro-Albert, Brent J.; Siemens, Xavier; Simon, Joseph; Spiwak, Renée; Stairs, Ingrid H.; Stinebring, Daniel R.; Stovall, Kevin; Sun, Jerry P.; Swiggum, Joseph K.; Taylor, Stephen R.; Turner, Jacob E.; Vallisneri, Michele; Vigeland, Sarah J.; Witt, Caitlin A.; Zurek, Kathryn M.; Nanograv Collaboration "Searching for Gravitational Waves from Cosmological Phase Transitions with the NANOGrav 12.5-Year Dataset" *Physical Review Letters*, 127 :251302, 2021.
- Arzoumanian, Zaven; Baker, Paul T.; Brazier, Adam; Brook, Paul R.; Burke-Spolaor, Sarah; Becs, Bence; Charisi, Maria; Chatterjee, Shami; Cordes, James M.; Cornish, Neil J.; Crawford, Fronefield; Cromartie, H. Thankful; Decesar, Megan E.; Demorest, Paul B.; Dolch, Timothy; Elliott, Rodney D.; Ellis, Justin A.; Ferrara, Elizabeth C.; Fonseca, Emmanuel; Garver-Daniels, Nathan; Gentile, Peter A.; Good, Deborah C.; Hazboun, Jeffrey S.; Islo, Kristina; Jennings, Ross J.; Jones, Megan L.; Kaiser, Andrew R.; Kaplan, David L.; Kelley, Luke Zoltan; Key, Joey Shapiro; Lam, Michael T.; Lazio, T. Joseph W.; Luo, Jing; Lynch, Ryan S.; Ma, Chung-Pei; Madison, Dustin R.; Mclaughlin, Maura A.; Mingarelli, Chiara M. F.; Ng, Cherry; Nice, David J.; Pennucci, Timothy T.; Pol, Nihan S.; Ransom, Scott M.; Ray, Paul S.; Shapiro-Albert, Brent J.; Siemens, Xavier; Simon, Joseph; Spiwak, Renée; Stairs, Ingrid H.; Stinebring, Daniel R.; Stovall, Kevin; Swiggum, Joseph K.; Taylor, Stephen R.; Vallisneri, Michele; Vigeland, Sarah J.; Witt, Caitlin A.; Nanograv Collaboration "The NANOGrav 11 yr Data Set: Limits on Supermassive Black Hole Binaries in Galaxies within 500 Mpc" *The Astrophysical Journal*, 914 :121, 2021.
- Aso, Yusuke; Kwon, Woojin; Hirano, Naomi; Ching, Tao-Chung; Lai, Shih-Ping; Li, Zhi-Yun; Rao, Ramprasad "Multi-scale Dust Polarization and Spiral-like Stokes-I Residual in the Class I Protostellar System TMC-1A" *The Astrophysical Journal*, 920 :71, 2021.
- Athanasiadis, Tilemachos M.; Berezina, Marina; Antoniadis, John; Champion, David J.; Cruces, Marilyn; Spittler, Laura; Kramer, Michael "A search for



- pulsar companions around low-mass white dwarfs" *Monthly Notices of the Royal Astronomical Society*, 505 :4981, 2021.
- Audibert, A.; Combes, F.; García-Burillo, S.; Hunt, L.; Eckart, A.; Aalto, S.; Casasola, V.; Boone, F.; Krips, M.; Viti, S.; Müller, S.; Dasyra, K.; Van Der Werf, P.; Martín, S. "Black hole feeding and star formation in NGC 1808" *Astronomy and Astrophysics*, 656 :A60, 2021.
- Avison, A.; Fuller, G. A.; Peretto, N.; Duarte-Cabral, A.; Rosen, A. L.; Traficante, A.; Pineda, J. E.; Güsten, R.; Cunningham, N. "Continuity of accretion from clumps to Class 0 high-mass protostars in SDC335" *Astronomy and Astrophysics*, 645 :A142, 2021.
- Bachetti, Matteo; Pilia, Maura; Huppenkothen, Daniela; Ransom, Scott M.; Curatti, Stefano; Ridolfi, Alessandro "Extending the ZZn and H Statistics to Generic Pulsed Profiles" *The Astrophysical Journal*, 909 :33, 2021.
- Bailes, M.; Berger, B. K.; Brady, P. R.; Branchesi, M.; Danzmann, K.; Evans, M.; Holley-Bockelmann, K.; Iyer, B. R.; Kajita, T.; Katsanevas, S.; Kramer, M.; Lazzarini, A.; Lehner, L.; Losurdo, G.; Lück, H.; McClelland, D. E.; McLaughlin, M. A.; Punturo, M.; Ransom, S.; Raychaudhury, S.; Reitze, D. H.; Ricci, F.; Rowan, S.; Saito, Y.; Sanders, G. H.; Sathyaprakash, B. S.; Schutz, B. F.; Sesana, A.; Shinkai, H.; Siemens, X.; Shoemaker, D. H.; Thorpe, J.; Van Den Brand, J. F. J.; Vitale, S. "Gravitational-wave physics and astronomy in the 2020s and 2030s" *Nature Reviews Physics*, 3 :344, 2021.
- Bakx, Tom J. L. C.; Sommovigo, Laura; Carniani, Stefano; Ferrara, Andrea; Akins, Hollis B.; Fujimoto, Seiji; Hagimoto, Masato; Knudsen, Kirsten K.; Pallottini, Andrea; Tamura, Yoichi; Watson, Darach "Accurate dust temperature determination in a  $z = 7.13$  galaxy" *Monthly Notices of the Royal Astronomical Society*, 508 :L58, 2021.
- Balasubramanian, A.; Corsi, A.; Polisenky, E.; Clarke, T. E.; Kassim, N. E. "Radio Observations of SN2004dk with VLITE Confirm Late-time Rebrightening" *The Astrophysical Journal*, 923 :32, 2021.
- Balasubramanian, Arvind; Corsi, Alessandra; Mooley, Kunal P.; Brightman, Murray; Hallinan, Gregg; Hotokezaka, Kenta; Kaplan, David L.; Lazzati, Davide; Murphy, Eric J. "Continued Radio Observations of GW170817 3.5 yr Post-merger" *The Astrophysical Journal*, 914 :L20, 2021.
- Baldi, Ranieri D.; Giovannini, Gabriele; Capetti, Alessandro "The eMERLIN and EVN View of FR 0 Radio Galaxies" *Galaxies*, 9 :106, 2021.
- Balsler, Dana S.; Wenger, Trey V.; Anderson, L. D.; Armentrout, W. P.; Bania, T. M.; Dawson, J. R.; Dickey, John M. "Discovery of a New Population of Galactic H II Regions with Ionized Gas Velocity Gradients" *The Astrophysical Journal*, 921 :176, 2021.
- Bañados, Eduardo; Mazzucchelli, Chiara; Momjian, Emmanuel; Eilers, Anna-Christina; Wang, Feige; Schindler, Jan-Torge; Connor, Thomas; Andika, Irfham Taufik; Barth, Aaron J.; Carilli, Chris; Davies, Frederick B.; Decarli, Roberto; Fan, Xiaohui; Farina, Emanuele Paolo; Hennawi, Joseph F.; Pensabene, Antonio; Stern, Daniel; Venemans, Bram P.; Wenzl, Lukas; Yang, Jinyi "The Discovery of a Highly Accreting, Radio-loud Quasar at  $z = 6.82$ " *The Astrophysical Journal*, 909 :80, 2021.
- Banerjee, Abhishek; Madge, Eric; Perez, Gilad; Ratzinger, Wolfram; Schwaller, Pedro "Gravitational wave echo of relaxation trapping" *Physical Review D*, 104 :55026, 2021.
- Banerji, Manda; Jones, Gareth C.; Carniani, Stefano; Degraf, Colin; Wagg, Jeff "Resolving discs and mergers in  $z \sim 2$  heavily reddened quasars and their companion galaxies with ALMA" *Monthly Notices of the Royal Astronomical Society*, 503 :5583, 2021.
- Bania, T. M.; Balsler, Dana S. "Green Bank Telescope Observations of 3He+ Planetary Nebulae" *The Astrophysical Journal*, 910 :73, 2021.
- Barnes, A. T.; Glover, S. C. O.; Kreckel, K.; Ostriker, E. C.; Bigiel, F.; Belfiore, F.; Bešlić, I.; Blanc, G. A.; Chevance, M.; Dale, D. A.; Egorov, O.; Eibensteiner, C.; Emsellem, E.; Grasha, K.; Groves, B. A.; Klessen, R. S.; Kruijssen, J. M. D.; Leroy, A. K.; Longmore, S. N.; Lopez, L.; Mcelroy, R.; Meidt, S. E.; Murphy, E. J.; Rosolowsky, E.; Saito, T.; Santoro, F.; Schinnerer, E.; Schrubba, A.; Sun, J.; Watkins, E. J.; Williams, T. G. "Comparing the pre-SNe feedback and environmental pressures for 6000 H II regions across 19 nearby spiral galaxies" *Monthly Notices of the Royal Astronomical Society*, 508 :5362, 2021.
- Barnes, A. T.; Henshaw, J. D.; Fontani, F.; Pineda, J. E.; Cosentino, G.; Tan, J. C.; Caselli, P.; Jiménez-Serra, I.; Law, C. Y.; Avison, A.; Bigiel, F.; Feng, S.; Kong, S.; Longmore, S. N.; Moser, L.; Parker, R. J.; Sánchez-Monge, Á.; Wang, K. "ALMA-IRDC: dense gas mass distribution from cloud to core scales" *Monthly Notices of the Royal Astronomical Society*, 503 :4601, 2021.
- Barrientos, Alejandro; Holdship, Jonathan; Solar, Mauricio; Martín, Sergio; Rivilla, Víctor M.; Viti, Serena; Mangum, Jeff; Harada, Nanase; Sakamoto, Kazushi; Müller, Sébastien; Tanaka, Kunihiko; Yoshimura, Yuki; Nakanishi, Kouichiro; Herrero-Illana, Rubén; Mühle, Stefanie; Aladro, Rebeca; Aalto, Susanne; Henkel, Christian; Humire, Pedro "Towards the prediction of molecular parameters from astronomical emission lines using Neural Networks" *Experimental Astronomy*, :, 2021.
- Bassani, L.; Ursini, F.; Malizia, A.; Bruni, G.; Panessa, F.; Masetti, N.; Saviane, I.; Monaco, L.; Venturi, T.; Dallacasa, D.; Bazzano, A.; Ubertini, P. "Soft gamma-ray selected giant radio galaxies: an update" *Monthly Notices of the Royal Astronomical Society*, 500 :3111, 2021.
- Bassett, Neil; Rapetti, David; Tauscher, Keith; Nhan, Bang D.; Bordenave, David D.; Hibbard, Joshua J.; Burns, Jack O. "Lost Horizon: Quantifying the Effect of Local Topography on Global 21 cm Cosmology Data Analysis" *The Astrophysical Journal*, 923 :33, 2021.
- Basu, Aritra; Goswami, Jishnu; Schwarz, Dominik J.; Urakawa, Yuko "Searching for Axionlike Particles under Strong Gravitational Lenses" *Physical Review Letters*, 126 :191102, 2021.
- Battaglia, Marina; Sharma, Rohit; Luo, Yingjie; Chen, Bin; Yu, Sijie; Krucker, Säm "Multiple Electron Acceleration Instances during a Series of Solar Microflares Observed Simultaneously at X-Rays and Microwaves" *The Astrophysical Journal*, 922 :134, 2021.
- Baug, T.; Wang, Ke; Liu, Tie; Wu, Yue-Fang; Li, Di; Zhang, Qizhou; Tang, Mengyao; Goldsmith, Paul F.; Liu, Hong-Li; Tej, Anandmayee; Bronfman, Leonardo; Kim, Kee-Tae; Li, Shanghuo; Lee, Chang Won; Tatematsu, Ken'ichi; Hirota, Tomoya; Toth, L. Viktor "An ALMA study of outflow parameters of protoclusters: outflow feedback to maintain the turbulence" *Monthly Notices of the Royal Astronomical Society*, 507 :4316, 2021.
- Bayandina, O. S.; Val'Ts, I. E.; Kurtz, S. E.; Shakhvorostova, N. N. "Search for Collisionally Pumped 1720 MHz OH Masers in Star-forming Regions: A VLA Survey of 18 cm OH Masers toward 80 Class I Methanol Masers" *The Astrophysical Journal Supplement Series*, 256 :7, 2021.
- Beltrán, M. T.; Rivilla, V. M.; Cesaroni, R.; Maud, L. T.; Galli, D.; Moscadelli, L.; Lorenzani, A.; Ahmadi, A.; Beuther, H.; Csengeri, T.; Etoka, S.; Goddi, C.; Klaassen, P. D.; Kuiper, R.; Kumar, M. S. N.; Peters, T.; Sánchez-Monge, Á.; Schilke, P.; Van Der Tak, F.; Vig, S.; Zinnecker, H. "Fragmentation in the massive G31.41+0.31 protocluster" *Astronomy and Astrophysics*, 648 :A100, 2021.
- Benaglia, Paula; Del Palacio, Santiago; Hales, Christopher; Colazo, Marcelo E. "High-sensitivity radio study of the non-thermal stellar bow shock EB27" *Monthly Notices of the Royal Astronomical Society*, 503 :2514, 2021.
- Benisty, Myriam; Bae, Jaehan; Facchini, Stefano; Kepler, Miriam; Teague, Richard; Isella, Andrea; Kurtovic, Nicolas T.; Pérez, Laura M.; Sierra, Anibal; Andrews, Sean M.; Carpenter, John; Czekala, Ian; Dominik, Carsten; Henning, Thomas; Menard, Francois; Pinilla, Paola; Zurlo, Alice "A Circumplanetary Disk around PDS70c" *The Astrophysical Journal*, 916 :L2, 2021.
- Bergner, Jennifer B.; Öberg, Karin I.; Guzmán, Viviana V.; Law, Charles J.; Loomis, Ryan A.; Cataldi, Gianni; Bosman, Arthur D.; Aikawa, Yuri; Andrews, Sean M.; Bergin, Edwin A.; Booth, Alice S.; Cleeves, L. Ilseidore; Czekala, Ian; Huang, Jane; Ilee, John D.; Le Gal, Romane; Long, Feng; Nomura, Hideko; Ménard, François; Qi, Chunhua; Schwarz, Kamber R.; Teague, Richard; Tsukagoshi, Takashi; Walsh, Catherine; Wilner, David J.; Yamato, Yoshihide "Molecules with ALMA at Planet-

## APPENDIX A: PUBLICATIONS

- forming Scales (MAPS). XI. CN and HCN as Tracers of Photochemistry in Disks" *The Astrophysical Journal Supplement Series*, 257 :11, 2021.
- Berta, S.; Young, A. J.; Cox, P.; Neri, R.; Jones, B. M.; Baker, A. J.; Omont, A.; Dunne, L.; Carnero Rosell, A.; Marchetti, L.; Negrello, M.; Yang, C.; Riechers, D. A.; Dannerbauer, H.; Perez-Fournon, I.; Van Der Werf, P.; Bakx, T.; Ivison, R. J.; Beelen, A.; Buat, V.; Cooray, A.; Cortzen, I.; Dye, S.; Eales, S.; Gavazzi, R.; Harris, A. I.; Herrera, C. N.; Hughes, D.; Jin, S.; Krips, M.; Lagache, G.; Lehnert, M.; Messias, H.; Serjeant, S.; Stanley, F.; Urquhart, S.; Vlahakis, C.; Weiß, A. "Close-up view of a luminous star-forming galaxy at  $z = 2.95$ " *Astronomy and Astrophysics*, 646 :A122, 2021.
- Bešlić, I.; Barnes, A. T.; Bigiel, F.; Puschig, J.; Pety, J.; Herrera Contreras, C.; Leroy, A. K.; Usero, A.; Schinnerer, E.; Meidt, S. E.; Emsellem, E.; Hughes, A.; Faesi, C.; Kreckel, K.; Belfiore, F. M. C.; Chevalance, M.; Den Brok, J. S.; Eibensteiner, C.; Glover, S. C. O.; Grasha, K.; Jimenez-Donaire, M. J.; Klessen, R. S.; Kruijssen, J. M. D.; Liu, D.; Pessa, I.; Querejeta, M.; Rosolowsky, E.; Saito, T.; Santoro, F.; Schruha, A.; Sormani, M. C.; Williams, T. G. "Dense molecular gas properties on 100 pc scales across the disc of NGC 3627" *Monthly Notices of the Royal Astronomical Society*, 506 :963, 2021.
- Bewketu Belete, A.; Andreani, P.; Fernández-Ontiveros, J. A.; Hatziminaoglou, E.; Combes, F.; Sirressi, M.; Slater, R.; Ricci, C.; Dasyra, K.; Cicone, C.; Aalto, S.; Spinoglio, L.; Imanishi, M.; De Medeiros, J. R. "Molecular gas kinematics in the nuclear region of nearby Seyfert galaxies with ALMA" *Astronomy and Astrophysics*, 654 :A24, 2021.
- Bhadari, N. K.; Dewangan, L. K.; Zemlyanukha, P. M.; Ojha, D. K.; Zinchenko, I. I.; Sharma, Saurabh "Probing Gas Kinematics and PDR Structure around O-type Stars in the Sh 2-305 H II Region" *The Astrophysical Journal*, 922 :207, 2021.
- Bhakta, D.; Mooley, K. P.; Corsi, A.; Balasubramanian, A.; Dobie, D.; Frail, D. A.; Hallinan, G.; Kaplan, D. L.; Myers, S. T.; Singer, L. P. "The JAGWAR Prowls LIGO/Virgo O3 Paper I: Radio Search of a Possible Multi-Messenger Counterpart of the Binary Black Hole Merger Candidate S191216ap" *The Astrophysical Journal*, 911 :77, 2021.
- Bhardwaj, M.; Gaensler, B. M.; Kaspi, V. M.; Landecker, T. L.; Mckinven, R.; Michilli, D.; Pleunis, Z.; Tendulkar, S. P.; Andersen, B. C.; Boyle, P. J.; Cassanelli, T.; Chawla, P.; Cook, A.; Dobbs, M.; Fonseca, E.; Kaczmarek, J.; Leung, C.; Masui, K.; Mnchmeyer, M.; Ng, C.; Rafiei-Ravandi, M.; Scholz, P.; Shin, K.; Smith, K. M.; Stairs, I. H.; Zwaniga, A. V. "A Nearby Repeating Fast Radio Burst in the Direction of M81" *The Astrophysical Journal*, 910 :L18, 2021.
- Bhardwaj, M.; Kirichenko, A. Yu.; Michilli, D.; Mayya, Y. D.; Kaspi, V. M.; Gaensler, B. M.; Rahman, M.; Tendulkar, S. P.; Fonseca, E.; Josephy, Alexander; Leung, C.; Merryfield, Marcus; Petroff, Emily; Pleunis, Z.; Sanghavi, Pranav; Scholz, P.; Shin, K.; Smith, Kendrick M.; Stairs, I. H. "A Local Universe Host for the Repeating Fast Radio Burst FRB 20181030A" *The Astrophysical Journal*, 919 :L24, 2021.
- Bhattacharya, Sukannya; Mohanty, Subhendra; Parashari, Priyank "Implications of the NANOGrav result on primordial gravitational waves in nonstandard cosmologies" *Physical Review D*, 103 :63532, 2021.
- Bhattacharyya, B.; Roy, J.; Johnson, T. J.; Ray, P. S.; Freire, P. C. C.; Gupta, Y.; Bhattacharya, D.; Kaniingat, A.; Stappers, B. W.; Ferrara, E. C.; Sengupta, S.; Rathour, R. S.; Kerr, M.; Smith, D. A.; Saz Parkinson, P. M.; Ransom, S. M.; Michelson, P. F. "Discovery and Timing of Three Millisecond Pulsars in Radio and Gamma-Rays with the Giant Metrewave Radio Telescope and Fermi Large Area Telescope" *The Astrophysical Journal*, 910 :160, 2021.
- Bian, Ligong; Cai, Rong-Gen; Liu, Jing; Yang, Xing-Yu; Zhou, Ruiyu "Evidence for different gravitational-wave sources in the NANOGrav dataset" *Physical Review D*, 103 :L081301, 2021.
- Bietenholz, M. F.; Bartel, N.; Argo, M.; Dua, R.; Ryder, S.; Soderberg, A. "The Radio Luminosity-risetime Function of Core-collapse Supernovae" *The Astrophysical Journal*, 908 :75, 2021.
- Bietenholz, Michael F.; Bartel, Norbert; Kamble, Atish; Margutti, Raffaella; Matthews, David Jacob; Milisavljevic, Danny "SN 2014C: VLBI image shows a shell structure and decelerated expansion" *Monthly Notices of the Royal Astronomical Society*, 502 :1694, 2021.
- Biggs, A. D. "The time delay of CLASS B1600+434 from VLA multi-frequency and polarization monitoring" *Monthly Notices of the Royal Astronomical Society*, 505 :2610, 2021.
- Binggeli, C.; Inoue, A. K.; Hashimoto, T.; Toribio, M. C.; Zackrisson, E.; Ramstedt, S.; Mawatari, K.; Harikane, Y.; Matsuo, H.; Okamoto, T.; Ota, K.; Shimizu, I.; Tamura, Y.; Taniguchi, Y.; Umehata, H. "A puzzling non-detection of [O III] and [C II] from a  $z \approx 7.7$  galaxy observed with ALMA" *Astronomy and Astrophysics*, 646 :A26, 2021.
- Birkin, Jack E.; Weiss, Axel; Wardlow, J. L.; Smail, Ian; Swinbank, A. M.; Dudzevičiūtė, U.; An, Fang Xia; Ao, Y.; Chapman, S. C.; Chen, Chian-Chou; Da Cunha, E.; Dannerbauer, H.; Gullberg, B.; Hodge, J. A.; Ikarashi, S.; Ivison, R. J.; Matsuda, Y.; Stach, S. M.; Walter, F.; Wang, W.-H.; Van Der Werf, P. "An ALMA/NOEMA survey of the molecular gas properties of high-redshift star-forming galaxies" *Monthly Notices of the Royal Astronomical Society*, 501 :3926, 2021.
- Bischetti, M.; Feruglio, C.; Piconcelli, E.; Duras, F.; Pérez-Torres, M.; Herrero, R.; Venturi, G.; Carniani, S.; Bruni, G.; Gavignaud, I.; Testa, V.; Bongiorno, A.; Brusa, M.; Circosta, C.; Cresci, G.; D'Odorico, V.; Maiolino, R.; Marconi, A.; Mingozzi, M.; Pappalardo, C.; Perna, M.; Traianou, E.; Travascio, A.; Vietri, G.; Zappacosta, L.; Fiore, F. "The WISSH quasars project. IX. Cold gas content and environment of luminous QSOs at  $z = 2.4-4.7$ " *Astronomy and Astrophysics*, 645 :A33, 2021.
- Blanco-Pillado, Jose J.; Olum, Ken D.; Wachter, Jeremy M. "Comparison of cosmic string and superstring models to NANOGrav 12.5-year results" *Physical Review D*, 103 :103512, 2021.
- Blasi, Simone; Brdar, Vedran; Schmitz, Kai "Has NANOGrav Found First Evidence for Cosmic Strings?" *Physical Review Letters*, 126 :41305, 2021.
- Blumer, Harsha; Safi-Harb, Samar; Mclaughlin, Maura A.; Fiore, William "Reactivation of the High Magnetic Field Pulsar PSR J1846-0258 with Magnetar-like Bursts" *The Astrophysical Journal*, 911 :L6, 2021.
- Boccardi, B.; Perucho, M.; Casadio, C.; Grandi, P.; Macconi, D.; Torresi, E.; Pellegrini, S.; Krichbaum, T. P.; Kadler, M.; Giovannini, G.; Karamanavis, V.; Ricci, L.; Madika, E.; Bach, U.; Ros, E.; Giroletti, M.; Zensus, J. A. "Jet collimation in NGC 315 and other nearby AGN" *Astronomy and Astrophysics*, 647 :A67, 2021.
- Boehler, Y.; Ménard, F.; Robert, C. M. T.; Isella, A.; Pinte, C.; Gonzalez, J.-F.; Van Der Plas, G.; Weaver, E.; Teague, R.; Garg, H.; Méheut, H. "Vortex-like kinematic signal, spirals, and beam smearing effect in the HD 142527 disk" *Astronomy and Astrophysics*, 650 :A59, 2021.
- Bogdanov, Slavko; Bahramian, Arash; Heinke, Craig O.; Freire, Paulo C. C.; Hessels, Jason W. T.; Ransom, Scott M.; Stairs, Ingrid H. "A Deep Chandra X-Ray Observatory Study of the Millisecond Pulsar Population in the Globular Cluster Terzan 5" *The Astrophysical Journal*, 912 :124, 2021.
- Boizelle, Benjamin D.; Walsh, Jonelle L.; Barth, Aaron J.; Buote, David A.; Baker, Andrew J.; Darling, Jeremy; Ho, Luis C.; Cohn, Jonathan; Kabasares, Kyle M. "Black Hole Mass Measurements of Radio Galaxies NGC 315 and NGC 4261 Using ALMA CO Observations" *The Astrophysical Journal*, 908 :19, 2021.
- Bojičić, I. S.; Filipović, M. D.; Urošević, D.; Parker, Q. A.; Galvin, T. J. "Determination of Planetary Nebulae angular diameters from radio continuum spectral energy distribution modelling" *Monthly Notices of the Royal Astronomical Society*, 503 :2887, 2021.
- Bolatto, Alberto D.; Leroy, Adam K.; Levy, Rebecca C.; Meier, David S.; Mills, Elisabeth A. C.; Thompson, Todd A.; Emig, Kimberly L.; Villeux, Sylvain; Ott, Jürgen; Gorski, Mark; Walter, Fabian; Lopez, Laura A.; Lenkić, Laura "ALMA Imaging of a Galactic Molecular Outflow in NGC 4945" *The Astrophysical Journal*, 923 :83, 2021.
- Boogaard, Leindert A.; Bouwens, Rychard J.; Riechers, Dominik; Van Der Werf, Paul; Bacon, Roland; Matthee, Jorjyt; Stefanon, Mauro; Feltre,

- Anna; Maseda, Michael; Inami, Hanae; Aravena, Manuel; Brinchmann, Jarle; Carilli, Chris; Contini, Thierry; Decarli, Roberto; González-López, Jorge; Nanayakkara, Themija; Walter, Fabian "Measuring the Average Molecular Gas Content of Star-forming Galaxies at  $z = 3-4$ " *The Astrophysical Journal*, 916 :12, 2021.
- Booth, Alice S.; Tabone, Benoît; Ilee, John D.; Walsh, Catherine; Aikawa, Yuri; Andrews, Sean M.; Bae, Jaehan; Bergin, Edwin A.; Bergner, Jennifer B.; Bosman, Arthur D.; Calahan, Jenny K.; Cataldi, Gianni; Cleeves, L. Ilse; Czekala, Ian; Guzmán, Viviana V.; Huang, Jane; Law, Charles J.; Le Gal, Romane; Long, Feng; Loomis, Ryan A.; Ménard, François; Nomura, Hideko; Öberg, Karin I.; Qi, Chunhua; Schwarz, Kamber R.; Teague, Richard; Tsukagoshi, Takashi; Wilner, David J.; Yamato, Yoshihide; Zhang, Ke "Molecules with ALMA at Planet-forming Scales (MAPS). XVI. Characterizing the Impact of the Molecular Wind on the Evolution of the HD 163296 System" *The Astrophysical Journal Supplement Series*, 257 :16, 2021.
- Booth, Alice S.; Van Der Marel, Nienke; Leemker, Margot; Van Dishoeck, Ewine F.; Ohashi, Satoshi "A major asymmetric ice trap in a planet-forming disk. II. Prominent SO and SO<sub>2</sub> pointing to C/O < 1" *Astronomy and Astrophysics*, 651 :L6, 2021.
- Booth, Alice S.; Walsh, Catherine; Terwisscha Van Scheltinga, Jeroen; Van Dishoeck, Ewine F.; Ilee, John D.; Hogerheijde, Michiel R.; Kama, Mihkel; Nomura, Hideko "An inherited complex organic molecule reservoir in a warm planet-hosting disk" *Nature Astronomy*, 5 :684, 2021.
- Booth, Mark; Schulz, Michael; Krivov, Alexander V.; Marino, Sebastián; Pearce, Tim D.; Launhardt, Ralf "Resolving the outer ring of HD 38206 using ALMA and constraining limits on planets in the system" *Monthly Notices of the Royal Astronomical Society*, 500 :1604, 2021.
- Bordiu, C.; Bufano, F.; Cerrigone, L.; Umana, G.; Rizzo, J. R.; Buemi, C. S.; Leto, P.; Cavallaro, F.; Ingallinera, A.; Loru, S.; Triglilio, C.; Riggi, S. "A warm molecular ring in AG Car: composing the mass-loss puzzle" *Monthly Notices of the Royal Astronomical Society*, 500 :5500, 2021.
- Borkar, A.; Adhikari, T. P.; Różańska, A.; Markowitz, A. G.; Boorman, P.; Czerny, B.; Migliori, G.; De Marco, B.; Karas, V. "The multiphase environment in the centre of Centaurus A" *Monthly Notices of the Royal Astronomical Society*, 500 :3536, 2021.
- Bosman, Arthur D.; Alarcón, Felipe; Bergin, Edwin A.; Zhang, Ke; Van'T Hoff, Merel L. R.; Öberg, Karin I.; Guzmán, Viviana V.; Walsh, Catherine; Aikawa, Yuri; Andrews, Sean M.; Bergner, Jennifer B.; Booth, Alice S.; Cataldi, Gianni; Cleeves, L. Ilse; Czekala, Ian; Furuya, Kenji; Huang, Jane; Ilee, John D.; Law, Charles J.; Le Gal, Romane; Liu, Yao; Long, Feng; Loomis, Ryan A.; Ménard, François; Nomura, Hideko; Qi, Chunhua; Schwarz, Kamber R.; Teague, Richard; Tsukagoshi, Takashi; Yamato, Yoshihide; Wilner, David J. "Molecules with ALMA at Planet-forming Scales (MAPS). VII. Substellar O/H and C/H and Superstellar C/O in Planet-feeding Gas" *The Astrophysical Journal Supplement Series*, 257 :7, 2021.
- Bosman, Arthur D.; Bergin, Edwin A. "Reimagining the Water Snowline" *The Astrophysical Journal*, 918 :L10, 2021.
- Bosman, Arthur D.; Bergin, Edwin A.; Loomis, Ryan A.; Andrews, Sean M.; Van'T Hoff, Merel L. R.; Teague, Richard; Öberg, Karin I.; Guzmán, Viviana V.; Walsh, Catherine; Aikawa, Yuri; Alarcón, Felipe; Bae, Jaehan; Bergner, Jennifer B.; Booth, Alice S.; Cataldi, Gianni; Cleeves, L. Ilse; Czekala, Ian; Huang, Jane; Ilee, John D.; Law, Charles J.; Le Gal, Romane; Liu, Yao; Long, Feng; Ménard, François; Nomura, Hideko; Pérez, Laura M.; Qi, Chunhua; Schwarz, Kamber R.; Sierra, Anibal; Tsukagoshi, Takashi; Yamato, Yoshihide; Wilner, David J.; Zhang, Ke "Molecules with ALMA at Planet-forming Scales (MAPS). XV. Tracing Protoplanetary Disk Structure within 20 au" *The Astrophysical Journal Supplement Series*, 257 :15, 2021.
- Botteon, A.; Giacintucci, S.; Gastaldello, F.; Venturi, T.; Brunetti, G.; Van Weeren, R. J.; Shimwell, T. W.; Rossetti, M.; Akamatsu, H.; Brüggem, M.; Cassano, R.; Cuciti, V.; De Gasperin, F.; Drabant, A.; Hoefl, M.; Mandal, S.; Röttgering, H. J. A.; Tasse, C. "Nonthermal phenomena in the center of Abell 1775. An 800 kpc head-tail, revived fossil plasma and slingshot radio halo" *Astronomy and Astrophysics*, 649 :A37, 2021.
- Bouvier, M.; López-Sepulcre, A.; Ceccarelli, C.; Sakai, N.; Yamamoto, S.; Yang, Y.-L. "ORion Alma New GEneration Survey (ORANGES). I. Dust continuum and free-free emission of OMC-2/3 filament protostars" *Astronomy and Astrophysics*, 653 :A117, 2021.
- Brajša, R.; Skokić, I.; Sudar, D.; Benz, A. O.; Krucker, S.; Ludwig, H.-G.; Saar, S. H.; Selhorst, C. L. "ALMA small-scale features in the quiet Sun and active regions" *Astronomy and Astrophysics*, 651 :A6, 2021.
- Braun, Teresa A. M.; Yen, Hsi-Wei; Koch, Patrick M.; Manara, Carlo F.; Miotello, Anna; Testi, Leonardo "Dynamical Stellar Masses of Pre-main-sequence Stars in Lupus and Taurus Obtained with ALMA Surveys in Comparison with Stellar Evolutionary Models" *The Astrophysical Journal*, 908 :46, 2021.
- Breiding, Peter; Burke-Spolaor, Sarah; Eracleous, Michael; Bogdanović, Tamara; Lazio, T. Joseph W.; Runnoe, Jessie; Sigurdsson, Steinn "The Search for Binary Supermassive Black Holes among Quasars with Offset Broad Lines Using the Very Long Baseline Array" *The Astrophysical Journal*, 914 :37, 2021.
- Britzen, S.; Zajaček, M.; Popović, L. Č.; Fendt, C.; Tramacere, A.; Pashchenko, I. N.; Jaron, F.; Pánis, R.; Petrov, L.; Aller, M. F.; Aller, H. D. "A ring accelerator? Unusual jet dynamics in the IceCube candidate PKS 1502+106" *Monthly Notices of the Royal Astronomical Society*, 503 :3145, 2021.
- Bron, Emeric; Roueff, Evelyne; Gerin, Maryvonne; Pety, Jérôme; Gratier, Pierre; Le Petit, Franck; Guzman, Viviana; Orkisz, Jan H.; De Souza Magalhaes, Victor; Gaudel, Mathilde; Vono, Maxime; Bardeau, Sébastien; Chainais, Pierre; Goicoechea, Javier R.; Hughes, Annie; Kainulainen, Jouni; Languignon, David; Le Bourlot, Jacques; Levrier, François; Liszt, Harvey; Öberg, Karin; Peretto, Nicolas; Roueff, Antoine; Sievers, Albrecht "Tracers of the ionization fraction in dense and translucent gas. I. Automated exploitation of massive astrochemical model grids" *Astronomy and Astrophysics*, 645 :A28, 2021.
- Brown, Toby; Wilson, Christine D.; Zabel, Nikki; Davis, Timothy A.; Boselli, Alessandro; Chung, Aeree; Ellison, Sara L.; Lagos, Claudia D. P.; Stevens, Adam R. H.; Cortese, Luca; Bahé, Yannick M.; Bisaria, Dhruv; Bolatto, Alberto D.; Cashmore, Claire R.; Catinella, Barbara; Chown, Ryan; Diemer, Benedikt; Elahi, Pascal J.; Hani, Maan H.; Jiménez-Donaire, María J.; Lee, Bumhyun; Leidig, Katya; Mok, Angus; Olsen, Karen Pardos; Parker, Laura C.; Roberts, Ian D.; Smith, Rory; Spekkens, Kristine; Thorp, Mallory; Tonnesen, Stephanie; Vienneau, Evan; Villanueva, Vicente; Vogel, Stuart N.; Wadsley, James; Welker, Charlotte; Yoon, Hyein "VERTICO: The Virgo Environment Traced in CO Survey" *The Astrophysical Journal Supplement Series*, 257 :21, 2021.
- Brunetti, Nathan; Wilson, Christine D.; Sliwa, Kazimierz; Schinnerer, Eva; Aalto, Susanne; Peck, Alison B. "Highly turbulent gas on GMC scales in NGC 3256, the nearest luminous infrared galaxy" *Monthly Notices of the Royal Astronomical Society*, 500 :4730, 2021.
- Bruni, G.; Brienza, M.; Panessa, F.; Bassani, L.; Dallacasa, D.; Venturi, T.; Baldi, R. D.; Botteon, A.; Drabent, A.; Malizia, A.; Massaro, F.; Röttgering, H. J. A.; Ubertini, P.; Ursini, F.; Van Weeren, R. J. "Hard X-ray selected giant radio galaxies - III. The LOFAR view" *Monthly Notices of the Royal Astronomical Society*, 503 :4681, 2021.
- Bruni, G.; Gómez, J. L.; Vega-García, L.; Lobanov, A. P.; Fuentes, A.; Savolainen, T.; Kovalev, Y. Y.; Perucho, M.; Martí, J.-M.; Anderson, J. M.; Edwards, P. G.; Gurvits, L. I.; Lisakov, M. M.; Pushkarev, A. B.; Sokolovsky, K. V.; Zensus, J. A. "RadioAstron reveals a spine-sheath jet structure in 3C 273" *Astronomy and Astrophysics*, 654 :A27, 2021.
- Bruni, G.; O'Connor, B.; Matsumoto, T.; Troja, E.; Piran, T.; Piro, L.; Ricci, R. "Late-time radio observations of the short GRB 200522A: constraints on the magnetar model" *Monthly Notices of the Royal Astronomical Society*, 505 :L41, 2021.
- Bruno, L.; Rajpurohit, K.; Brunetti, G.; Gastaldello, F.; Botteon, A.; Iagnesi,

## APPENDIX A: PUBLICATIONS

- A.; Bonafede, A.; Dallacasa, D.; Cassano, R.; Van Weeren, R. J.; Cuciti, V.; Di Gennaro, G.; Shimwell, T.; Brüggem, M. "The LOFAR and JVLA view of the distant steep spectrum radio halo in MACS J1149.5+2223" *Astronomy and Astrophysics*, 650 :A44, 2021.
- Brunthaler, A.; Menten, K. M.; Dzib, S. A.; Cotton, W. D.; Wyrowski, F.; Dokara, R.; Gong, Y.; Medina, S. -N. X.; Müller, P.; Nguyen, H.; Ortiz-León, G. N.; Reich, W.; Rugel, M. R.; Urquhart, J. S.; Winkel, B.; Yang, A. Y.; Beuther, H.; Billington, S.; Carrasco-Gonzalez, C.; Csengeri, T.; Murugesan, C.; Pandian, J. D.; Roy, N. "A global view on star formation: The GLOSTAR Galactic plane survey. I. Overview and first results for the Galactic longitude range  $28^\circ < l < 36^\circ$ " *Astronomy and Astrophysics*, 651 :A85, 2021.
- Bruzewski, S.; Schinzel, F. K.; Taylor, G. B.; Petrov, L. "Radio Counterpart Candidates to 4FGL-DR2 Unassociated Sources" *The Astrophysical Journal*, vol 914 :42, 2021.
- Bujarrabal, V.; Agúndez, M.; Gómez-Garrido, M.; Kim, Hyosun; Santander-García, M.; Alcolea, J.; Castro-Carrizo, A.; Mikołajewska, J. "Structure and dynamics of the inner nebula around the symbiotic stellar system R Aquarii" *Astronomy and Astrophysics*, 651 :A4, 2021.
- Bulut, N.; Roncero, O.; Aguado, A.; Loison, J.-C.; Navarro-Almáida, D.; Wakelam, V.; Fuente, A.; Roueff, E.; Le Gal, R.; Caselli, P.; Gerin, M.; Hickson, K. M.; Spezzano, S.; Rivière-Marichalar, P.; Alonso-Albi, T.; Bachiller, R.; Jiménez-Serra, I.; Kramer, C.; Tercero, B.; Rodríguez-Baras, M.; García-Burillo, S.; Goicoechea, J. R.; Treviño-Morales, S. P.; Esplugues, G.; Cazaux, S.; Commerçon, B.; Laas, J.; Kirk, J.; Lattanzi, V.; Martín-Doménech, R.; Muñoz-Caro, G.; Pineda, J.; Ward-Thompson, D.; Tafalla, M.; Marcelino, N.; Malinen, J.; Friesen, R.; Giuliano, B. M.; Agúndez, M.; Hacar, A. "Gas phase Elemental abundances in Molecular cloud(S GEMS). III. Unlocking the CS chemistry: the CS+O reaction" *Astronomy and Astrophysics*, 646 :A5, 2021.
- Burke, Colin J.; Liu, Xin; Chen, Yu-Ching; Shen, Yue; Guo, Hengxiao "On the AGN nature of broad balmer emission in four low-redshift metal-poor galaxies" *Monthly Notices of the Royal Astronomical Society*, 504 :543, 2021.
- Burkhardt, Andrew M.; Long Kelvin Lee, Kin; Bryan Changala, P.; Shingledecker, Christopher N.; Cooke, Ilsa R.; Loomis, Ryan A.; Wei, Hongji; Charnley, Steven B.; Herbst, Eric; Mccarthy, Michael C.; Mcguire, Brett A. "Discovery of the Pure Polycyclic Aromatic Hydrocarbon Indene (c-C9H8) with GOTHAM Observations of TMC-1" *The Astrophysical Journal*, 913 :L18, 2021.
- Burkhardt, Andrew M.; Loomis, Ryan A.; Shingledecker, Christopher N.; Lee, Kin Long Kelvin; Remijan, Anthony J.; Mccarthy, Michael C.; Mcguire, Brett A. "Ubiquitous aromatic carbon chemistry at the earliest stages of star formation" *Nature Astronomy*, 5 :181, 2021.
- Burnham, Anne D.; Casey, Caitlin M.; Zavala, Jorge A.; Manning, Sinclair M.; Spilker, Justin S.; Chapman, Scott C.; Chen, Chian-Chou; Cooray, Asantha; Sanders, David B.; Scoville, Nick Z. "The Physical Drivers of the Luminosity-weighted Dust Temperatures in High-redshift Galaxies" *The Astrophysical Journal*, 910 :89, 2021.
- Busch, Michael P.; Engelke, Philip D.; Allen, Ronald J.; Hogg, David E. "Observational Evidence for a Thick Disk of Dark Molecular Gas in the Outer Galaxy" *The Astrophysical Journal*, 914 :72, 2021.
- Busekool, E.; Verheijen, M. A. W.; Van Der Hulst, J. M.; Tully, R. B.; Trentham, N.; Zwaan, M. A. "The Ursa Major association of galaxies - VI: a relative dearth of gas-rich dwarf galaxies" *Monthly Notices of the Royal Astronomical Society*, 501 :2608, 2021.
- Butler, Kirsty M.; Van Der Werf, Paul P.; Rybak, Matus; Costa, Tiago; Cox, Pierre; Weiß, Axel; Michałowski, Michał J.; Riechers, Dominik A.; Rigopoulou, Dimitra; Marchetti, Lucia; Eales, Stephen; Valtchanov, Ivan "Resolved Neutral Outflow from a Lensed Dusty Star-forming Galaxy at  $z = 2.09$ " *The Astrophysical Journal*, 919 :5, 2021.
- Cabedo, Victoria; Maury, Anaëlle; Girart, Josep M.; Padovani, Marco "Structured velocity field in the inner envelope of B335: ALMA observations of rare CO isotopologues" *Astronomy and Astrophysics*, 653 :A166, 2021.
- Calahan, Jenny K.; Bergin, Edwin A.; Zhang, Ke; Schwarz, Kamber R.; Öberg, Karin I.; Guzmán, Viviana V.; Walsh, Catherine; Aikawa, Yuri; Alarcón, Felipe; Andrews, Sean M.; Bae, Jaehan; Bergner, Jennifer B.; Booth, Alice S.; Bosman, Arthur D.; Cataldi, Gianni; Czekala, Ian; Huang, Jane; Ilee, John D.; Law, Charles J.; Le Gal, Romane; Long, Feng; Loomis, Ryan A.; Ménard, François; Nomura, Hideko; Qi, Chunhua; Teague, Richard; Van'T Hoff, Merel L. R.; Wilner, David J.; Yamato, Yoshihide "Molecules with ALMA at Planet-forming Scales (MAPS). XVII. Determining the 2D Thermal Structure of the HD 163296 Disk" *The Astrophysical Journal Supplement Series*, 257 :17, 2021.
- Calahan, Jenny K.; Bergin, Edwin; Zhang, Ke; Teague, Richard; Cleeves, Ilseidore; Bergner, Jennifer; Blake, Geoffrey A.; Cazzoletti, Paolo; Guzmán, Viviana; Hogerheijde, Michiel R.; Huang, Jane; Kama, Mihkel; Loomis, Ryan; Öberg, Karin; Qi, Charlie; Van Dishoeck, Ewine F.; Terwisscha Van Scheltinga, Jeroen; Walsh, Catherine; Wilner, David "The TW Hya Rosetta Stone Project. III. Resolving the Gaseous Thermal Profile of the Disk" *The Astrophysical Journal*, 908 :8, 2021.
- Callanan, Daniel; Longmore, Steven N.; Kruijssen, J. M. Diederik; Schrubba, Andreas; Ginsburg, Adam; Krumholz, Mark R.; Bastian, Nate; Alves, João; Henshaw, Jonathan D.; Knapen, Johan H.; Chevanche, Mélanie "The centres of M83 and the Milky Way: opposite extremes of a common star formation cycle" *Monthly Notices of the Royal Astronomical Society*, 505 :4310, 2021.
- Calura, Francesco; Vanzella, Eros; Carniani, Stefano; Gilli, Roberto; Rosati, Piero; Meneghetti, Massimo; Paladino, Rosita; Decarli, Roberto; Brusa, Marcella; Lupi, Alessandro; D'Amato, Quirino; Bergamini, Pietro; Caminha, Gabriel B. "Constraints on the [CII] luminosity of a protoglobular cluster at  $z = 6$  obtained with ALMA" *Monthly Notices of the Royal Astronomical Society*, 500 :3083, 2021.
- Camilo, F.; Ransom, S. M.; Halpern, J. P.; Roshi, D. Anish "Radio Detection of PSR J1813-1749 in HESS J1813-178: The Most Scattered Pulsar Known" *The Astrophysical Journal*, 917 :67, 2021.
- Cañameras, R.; Nesvadba, N. P. H.; Kneissl, R.; König, S.; Yang, C.; Beelen, A.; Hill, R.; Le Floch, E.; Scott, D. "Planck's Dusty GEMS. VIII. Dense-gas reservoirs in the most active dusty starbursts at  $z = 3$ " *Astronomy and Astrophysics*, 645 :A45, 2021.
- Canta, Alessandra; Teague, Richard; Le Gal, Romane; Öberg, Karin I. "The First Detection of CH2CN in a Protoplanetary Disk" *The Astrophysical Journal*, 922 :62, 2021.
- Caputi, K. I.; Caminha, G. B.; Fujimoto, S.; Kohno, K.; Sun, F.; Egami, E.; Deshmukh, S.; Tang, F.; Ao, Y.; Bradley, L.; Coe, D.; Espada, D.; Grillo, C.; Hatsukade, B.; Knudsen, K. K.; Lee, M. M.; Magdis, G. E.; Morokuma-Matsui, K.; Oesch, P.; Ouchi, M.; Rosati, P.; Umehata, H.; Valentino, F.; Vanzella, E.; Wang, W.-H.; Wu, J. F.; Zitrin, A. "ALMA Lensing Cluster Survey: An ALMA Galaxy Signposting a MUSE Galaxy Group at  $z = 4.3$  Behind "El Gordo"" *The Astrophysical Journal*, 908 :146, 2021.
- Carlin, Jeffrey L.; Mutlu-Pakdil, Burçin; Crnojević, Denija; Garling, Christopher T.; Karunakaran, Ananthan; Peter, Annika H. G.; Tollerud, Erik; Forbes, Duncan A.; Hargis, Jonathan R.; Lim, Sungsoo; Romanowsky, Aaron J.; Sand, David J.; Spekkens, Kristine; Strader, Jay "Hubble Space Telescope Observations of Two Faint Dwarf Satellites of Nearby LMC Analogs from MADCASH" *The Astrophysical Journal*, 909 :211, 2021.
- Carotenuto, F.; Corbel, S.; Tremou, E.; Russell, T. D.; Tzioumis, A.; Fender, R. P.; Woudt, P. A.; Motta, S. E.; Miller-Jones, J. C. A.; Chauhan, J.; Tetarenko, A. J.; Sivakoff, G. R.; Heywood, I.; Horesh, A.; Van Der Horst, A. J.; Koerding, E.; Mooley, K. P. "The black hole transient MAXI J1348-630: evolution of the compact and transient jets during its 2019/2020 outburst" *Monthly Notices of the Royal Astronomical Society*, 504 :444, 2021.
- Carrasco-González, Carlos; Sanna, Alberto; Rodríguez-Kamenetzky, Adriana; Moscadelli, Luca; Hoare, Melvin; Torrelles, José M.; Galván-Madrid, Roberto; Izquierdo, Andrés F. "Zooming into the Collimation Zone in a Massive Protostellar Jet" *The Astrophysical Journal*, 914 :L1,

- 2021.
- Carvajal, Rodrigo; Matute, Israel; Afonso, José; Amarantidis, Stergios; Barbosa, Davi; Cunha, Pedro; Humphrey, Andrew "Exploring New Redshift Indicators for Radio-Powerful AGN Galaxies, 9 :86, 2021.
- Casadio, C.; Macdonald, N. R.; Boccardi, B.; Jorstad, S. G.; Marscher, A. P.; Krichbaum, T. P.; Hodgson, J. A.; Kim, J.-Y.; Traianou, E.; Weaver, Z. R.; Gómez Garrido, M.; González García, J.; Kallunki, J.; Lindqvist, M.; Sánchez, S.; Yang, J.; Zensus, J. A. "The jet collimation profile at high resolution in BL Lacertae" *Astronomy and Astrophysics*, 649 :A153, 2021.
- Casassus, Simon; Christiaens, Valentin; Cárcamo, Miguel; Pérez, Sebastián; Weber, Philipp; Ercolano, Barbara; Van Der Marel, Nienke; Pinte, Christophe; Dong, Ruobing; Baruteau, Clément; Cieza, Lucas; Van Dishoeck, Ewine F.; Jordan, Andrés; Price, Daniel J.; Absil, Olivier; Arce-Tord, Carla; Faramaz, Virginia; Flores, Christian; Reggiani, Maddalena "A dusty filament and turbulent CO spirals in HD 135344B - SAO 206462" *Monthly Notices of the Royal Astronomical Society*, 507 :3789, 2021.
- Casey, Caitlin M.; Zavala, Jorge A.; Manning, Sinclair M.; Aravena, Manuel; Béthermin, Matthieu; Caputi, Karina I.; Champagne, Jaclyn B.; Clements, David L.; Drew, Patrick; Finkelstein, Steven L.; Fujimoto, Seiji; Hayward, Christopher C.; Dekel, Anton M.; Kokorev, Vasily; Lagos, Claudia Del P.; Long, Arianna S.; Magdis, Georgios E.; Man, Allison W. S.; Mitsuhashi, Ikki; Popping, Gergö; Spilker, Justin; Staguhn, Johannes; Talia, Margherita; Toft, Sune; Treister, Ezequiel; Weaver, John R.; Yun, Min "Mapping Obscuration to Reionization with ALMA (MORA): 2 mm Efficiently Selects the Highest-redshift Obscured Galaxies" *The Astrophysical Journal*, 923 :215, 2021.
- Cashman, Frances H.; Fox, Andrew J.; Savage, Blair D.; Wakker, Bart P.; Krishnarao, Dhanesh; Benjamin, Robert A.; Richter, Philipp; Ashley, Trisha; Jenkins, Edward B.; Lockman, Felix J.; Bordoloi, Rongmon; Kim, Tae-Sun "Molecular Gas within the Milky Way's Nuclear Wind" *The Astrophysical Journal*, 923 :L11, 2021.
- Castelletti, G.; Supan, L.; Peters, W. M.; Kassim, N. E. "Thermal radio absorption as a tracer of the interaction of SNRs with their environments" *Astronomy and Astrophysics*, 653 :A62, 2021.
- Cataldi, Gianni; Yamato, Yoshihide; Aikawa, Yuri; Bergner, Jennifer B.; Furuya, Kenji; Guzmán, Viviana V.; Huang, Jane; Loomis, Ryan A.; Qi, Chunhua; Andrews, Sean M.; Bergin, Edwin A.; Booth, Alice S.; Bosman, Arthur D.; Cleeves, L. Ilse; Czekala, Ian; Ilee, John D.; Law, Charles J.; Le Gal, Romane; Liu, Yao; Long, Feng; Ménard, François; Nomura, Hideko; Öberg, Karin I.; Schwarz, Kamber R.; Teague, Richard; Tsukagoshi, Takashi; Walsh, Catherine; Wilner, David J.; Zhang, Ke "Molecules with ALMA at Planet-forming Scales (MAPS). X. Studying Deuteration at High Angular Resolution toward Protoplanetary Disks" *The Astrophysical Journal Supplement Series*, 257 :10, 2021.
- Cavalié, T.; Benmahi, B.; Hue, V.; Moreno, R.; Lellouch, E.; Fouchet, T.; Hartogh, P.; Rezac, L.; Greathouse, T. K.; Gladstone, G. R.; Sinclair, J. A.; Dobrijevic, M.; Billebaud, F.; Jarchow, C. "First direct measurement of auroral and equatorial jets in the stratosphere of Jupiter" *Astronomy and Astrophysics*, 647 :L8, 2021.
- Cendes, Y.; Alexander, K. D.; Berger, E.; Eftekhari, T.; Williams, P. K. G.; Chornock, R. "Radio Observations of an Ordinary Outflow from the Tidal Disruption Event AT2019dsg" *The Astrophysical Journal*, 919 :127, 2021.
- Cendes, Y.; Eftekhari, T.; Berger, E.; Polisensky, E. "Radio Monitoring of the Tidal Disruption Event Swift J164449.3+573451. IV. Continued Fading and Non-relativistic Expansion" *The Astrophysical Journal*, 908 :125, 2021.
- Chakali, Eswaraiah; Li, Di; Furuya, Ray S.; Hasegawa, Tetsuo; Ward-Thompson, Derek; Qiu, Keping; Ohashi, Nagayoshi; Pattle, Kate; Sadavoy, Sarah; Hull, Charles L. H.; Berry, David; Doi, Yasuo; Ching, Tao-Chung; Lai, Shih-Ping; Wang, Jia-Wei; Koch, Patrick M.; Kwon, Jungmi; Kwon, Woojin; Bastien, Pierre; Arzoumanian, Doris; Coudé, Simon; Soam, Archana; Fanciullo, Lapo; Yen, Hsi-Wei; Liu, Junhao; Hoang, Thiem; Ping Chen, Wen; Shimajiri, Yoshito; Liu, Tie; Chen, Zhiwei; Li, Hua-Bai; Lyo, A. -Ran; Hwang, Jihye; Johnstone, Doug; Rao, Ramprasad; Bich Ngoc, Nguyen; Ngoc Diep, Pham; Mairs, Steve; Parsons, Harriet; Tamura, Motohide; Tahani, Mehrnoosh; Vivien Chen, Huei-Ru; Nakamura, Fumitaka; Shinnaga, Hiroko; Tang, Ya-Wen; Cho, Jungyeon; Won Lee, Chang; Inutsuka, Shu-Chiro; Inoue, Tsuyoshi; Iwasaki, Kazunari; Qian, Lei; Xie, Jinjin; Li, Dalei; Liu, Hong-Li; Zhang, Chuan-Peng; Chen, Mike; Zhang, Guoyin; Zhu, Lei; Zhou, Jianjun; André, Philippe; Liu, Sheng-Yuan; Yuan, Jinghua; Lu, Xing; Peretto, Nicolas; Bourke, Tyler L.; Byun, Do-Young; Dai, Sophia; Duan, Yan; Duan, Hao-Yuan; Eden, David; Matthews, Brenda; Fiege, Jason; Fissel, Laura M.; Kim, Kee-Tae; Lee, Chin-Fei; Kim, Jongsoo; Pyo, Tae-Soo; Choi, Yunhee; Choi, Minho; Chrysostomou, Antonio; Jung Chung, Eun; Ngoc Tram, Le; Franzmann, Erica; Friberg, Per; Friesen, Rachel; Fuller, Gary; Gledhill, Tim; Graves, Sarah; Greaves, Jane; Griffin, Matt; Gu, Qilao; Han, Ilseung; Hatchell, Jennifer; Hayashi, Saeko; Houde, Martin; Kawabata, Koji; Jeong, Il-Gyo; Kang, Ji-Hyun; Kang, Sung-Ju; Kang, Miju; Kataoka, Akimasa; Kemper, Francisca; Rawlings, Mark; Rawlings, Jonathan; Retter, Brendan; Richer, John; Rigby, Andrew; Saito, Hiro; Savini, Giorgio; Scaife, Anna; Seta, Masumichi; Kim, Gwanjeong; Hee Kim, Kyoung; Kim, Mi-Ryang; Kirchschrager, Florian; Kirk, Jason; Kobayashi, Masato I. N.; Konyves, Vera; Kusune, Takayoshi; Lacaille, Kevin; Law, Chi-Yan; Lee, Sang-Sung; Lee, Yong-Hee; Matsumura, Masafumi; Moriarty-Schieven, Gerald; Nagata, Tetsuya; Nakanishi, Hiroyuki; Onaka, Takashi; Park, Geumsook; Tang, Xindi; Tomisaka, Kohji; Tsukamoto, Yusuke; Viti, Serena; Wang, Hongchi; Whitworth, Anthony; Yoo, Hyunju; Yun, Hyeong-Sik; Zenko, Tetsuya; Zhang, Yapeng; De Looze, Ilse; Dowell, C. Darren; Eyres, Stewart; Falle, Sam; Robitaille, Jean-François; Van Loo, Sven "The JCMT BISTRO Survey: Revealing the Diverse Magnetic Field Morphologies in Taurus Dense Cores with Sensitive Submillimeter Polarimetry" *The Astrophysical Journal*, 912 :L27, 2021.
- Chamani, Wara; Savolainen, Tuomas; Hada, Kazuhiro; Xu, Ming H. "Testing the magnetic flux paradigm for AGN radio loudness with a radio-intermediate quasar" *Astronomy and Astrophysics*, 652 :A14, 2021.
- Champagne, Jaclyn B.; Casey, Caitlin M.; Zavala, Jorge A.; Cooray, Asantha; Dannerbauer, Helmut; Fabian, Andrew; Hayward, Christopher C.; Long, Arianna S.; Spilker, Justin S. "Comprehensive Gas Characterization of a  $z = 2.5$  Protocluster: A Cluster Core Caught in the Beginning of Virialization?" *The Astrophysical Journal*, 913 :110, 2021.
- Chang, N.; Xie, F. G.; Liu, X.; Ho, L. C.; Dong, A.-J.; Han, Z. H.; Wang, X. "Possible evidence of a universal radio/X-ray correlation in a near-complete sample of hard X-ray selected seiyfert galaxies" *Monthly Notices of the Royal Astronomical Society*, 503 :1987, 2021.
- Chastenot, Jérémy; Sandstrom, Karin; Chiang, I-Da; Hensley, Brandon S.; Draine, Bruce T.; Gordon, Karl D.; Koch, Eric W.; Leroy, Adam K.; Utomo, Dyas; Williams, Thomas G. "Benchmarking Dust Emission Models in M101" *The Astrophysical Journal*, 912 :103, 2021.
- Chen, Chian-Chou; Arrigoni Battaia, Fabrizio; Emonts, Bjorn H. C.; Lehnert, Matthew D.; Prochaska, J. Xavier "A Multiwavelength Study of ELAN Environments (AMUSE2). Detection of a Dusty Star-forming Galaxy within the Enormous Ly $\alpha$  Nebula at  $z=2.3$  Sheds Light on its Origin" *The Astrophysical Journal*, 923 :200, 2021.
- Chen, Jheng-Cyun; Urata, Yuji; Huang, Kuiyun "ALMA Host Galaxy Observation of the Off-axis Gamma-Ray Burst XRF 020903" *The Astrophysical Journal*, 915 :46, 2021.
- Chen, Qingxiang; Meyer, Martin; Popping, Attila; Staveley-Smith, Lister; Bryant, Julia; Delhaize, Jacinta; Holwerda, B. W.; Cluver, M. E.; Loveday, J.; Lopez-Sanchez, Angel R.; Zwaan, Martin; Taylor, E. N.; Hopkins, A. M.; Wright, Angus; Driver, Simon; Brough, S. "Measuring cosmic density of neutral hydrogen via stacking the DINGO-VLA data" *Monthly Notices of the Royal Astronomical Society*, 508 :2758, 2021.
- Chen, Xi; Ren, Zhi-Yuan; Li, Da-Lei; Liu, Tie; Wang, Ke; Shen, Zhi-Qiang;

## APPENDIX A: PUBLICATIONS

- Ellingsen, Simon P.; Sobolev, Andrej M.; Mei, Ying; Li, Jing-Jing; Wu, Yue-Fang; Kim, Kee-Tae "Chemically Fresh Gas Inflows Detected in a Nearby High-mass Star-forming Region" *The Astrophysical Journal*, 923 :L20, 2021.
- Chen, Yu-Ching; Liu, Xin; Liao, Wei-Ting; Guo, Hengxiao "Very Large Array imaging rules out precessing radio jets in three DES-SDSS-selected candidate periodic quasars" *Monthly Notices of the Royal Astronomical Society*, 507 :4638, 2021.
- Chené, André-Nicolas; Benjamin, Robert A.; Ramírez-Alegría, Sebastian; Borissova, Jura; Kurtev, Radostin; Moni Bidin, Christian; Mauro, Francesco; Lucas, Phil; Guo, Zhen; Smith, Leigh C.; Gonzalez-Fernandez, Carlos; Ivanov, Valentin D.; Minniti, Dante; Anderson, Loren D.; Armentrout, William P.; Gonzalez, Danilo; Herrero, Artemio; Peña Ramírez, Karla "Assessing the Stellar Population and the Environment of an H II Region on the Far Side of the Galaxy" *The Astrophysical Journal*, 911 :91, 2021.
- Cheng, Xiaopeng; An, Tao; Sohn, Bong Won; Hong, Xiaoyu; Wang, Ailing "Parsec-scale properties of eight Fanaroff-Riley type 0 radio galaxies" *Monthly Notices of the Royal Astronomical Society*, 506 :1609, 2021.
- Cheng, Yu; Tan, Jonathan C.; Caselli, Paola; Fissel, Laura; Arce, Héctor G.; Fontani, Francesco; Goodson, Matthew D.; Liu, Mengyao; Galitzki, Nicholas "Star Formation in a Strongly Magnetized Cloud" *The Astrophysical Journal*, 916 :78, 2021.
- Chiang, I-Da; Sandstrom, Karin M.; Chastenet, Jérémy; Herrera, Cinthya N.; Koch, Eric W.; Kreckel, Kathryn; Leroy, Adam K.; Pety, Jérôme; Schrubba, Andreas; Utomo, Dyas; Williams, Thomas "Resolving the Dust-to-Metals Ratio and CO-to-H<sub>2</sub> Conversion Factor in the Nearby Universe" *The Astrophysical Journal*, 907 :18 pp, 2021.
- Chibueze, James O.; Macleod, Gordon C.; Vorster, Jakobus M.; Hirota, Tomoya; Brogan, Crystal L.; Hunter, Todd R.; Van Rooyen, Ruby "The Extraordinary Outburst in the Massive Protostellar System NGC 6334 I-MM1: Spatiokinematics of Water Masers during a Contemporaneous Flare Event" *The Astrophysical Journal*, 908 :175, 2021.
- Chime/Frb Collaboration; Amiri, Mandana; Andersen, Bridget C.; Bandura, Kevin; Berger, Sabrina; Bhardwaj, Mohit; Boyce, Michelle M.; Boyle, P. J.; Brar, Charanjot; Breitman, Daniela; Cassanelli, Tomas; Chawla, Pragya; Chen, Tianyue; Cliche, J.-F.; Cook, Amanda; Cubranic, Davor; Curtin, Alice P.; Deng, Meiling; Dobbs, Matt; Dong, Fengqiu Adam; Eadie, Gwendolyn; Fandino, Mateus; Fonseca, Emmanuel; Gaensler, B. M.; Giri, Utkarsh; Good, Deborah C.; Halpern, Mark; Hill, Alex S.; Hinshaw, Gary; Josephy, Alexander; Kaczmarek, Jane F.; Kader, Zarif; Kania, Joseph W.; Kaspi, Victoria M.; Landecker, T. L.; Lang, Dustin; Leung, Calvin; Li, Dongzi; Lin, Hsiu-Hsien; Masui, Kiyoshi W.; Mckinven, Ryan; Mena-Parra, Juan; Merryfield, Marcus; Meyers, Bradley W.; Michilli, Daniele; Milutinovic, Nikola; Mirhosseini, Arash; Münchmeyer, Moritz; Naidu, Arun; Newburgh, Laura; Ng, Cherry; Patel, Chitran; Pen, Ue-Li; Petroff, Emily; Pinsonneault-Marotte, Tristan; Pleunis, Ziggy; Rafiei-Ravandi, Masoud; Rahman, Mubdi; Ransom, Scott M.; Renard, Andre; Sanghavi, Pranav; Scholz, Paul; Shaw, J. Richard; Shin, Kaitlyn; Siegel, Seth R.; Sikora, Andrew E.; Singh, Saurabh; Smith, Kendrick M.; Stairs, Ingrid; Tan, Chia Min; Tendulkar, S. P.; Vanderlinde, Keith; Wang, Haochen; Wulf, Dallas; Zwaniga, A. V. "The First CHIME/FRB Fast Radio Burst Catalog" *The Astrophysical Journal Supplement Series*, 257 :59, 2021.
- Chime/Pulsar Collaboration; Amiri, M.; Bandura, K. M.; Boyle, P. J.; Brar, C.; Cliche, J.-F.; Crowter, K.; Cubranic, D.; Demorest, P. B.; Denman, N. T.; Dobbs, M.; Dong, F. Q.; Fandino, M.; Fonseca, E.; Good, D. C.; Halpern, M.; Hill, A. S.; Höfer, C.; Kaspi, V. M.; Landecker, T. L.; Leung, C.; Lin, H.-H.; Luo, J.; Masui, K. W.; Mckee, J. W.; Mena-Parra, J.; Meyers, B. W.; Michilli, D.; Naidu, A.; Newburgh, L.; Ng, C.; Patel, C.; Pinsonneault-Marotte, T.; Ransom, S. M.; Renard, A.; Scholz, P.; Shaw, J. R.; Sikora, A. E.; Stairs, I. H.; Tan, C. M.; Tendulkar, S. P.; Tret'yakov, I.; Vanderlinde, K.; Wang, H.; Wang, X. "The CHIME Pulsar Project: System Overview" *The Astrophysical Journal Supplement Series*, 255 :5, 2021.
- Chintzoglou, Georgios; De Pontieu, Bart; Martínez-Sykora, Juan; Hansteen, Viggo; De La Cruz Rodríguez, Jaime; Szydlarski, Mikolaj; Jafarzadeh, Shahin; Wedemeyer, Sven; Bastian, Timothy S.; Sainz Dalda, Alberto "ALMA and IRIS Observations of the Solar Chromosphere. I. An On-disk Type II Spicule" *The Astrophysical Journal*, 906 :82, 2021.
- Chintzoglou, Georgios; De Pontieu, Bart; Martínez-Sykora, Juan; Hansteen, Viggo; De La Cruz Rodríguez, Jaime; Szydlarski, Mikolaj; Jafarzadeh, Shahin; Wedemeyer, Sven; Bastian, Timothy S.; Sainz Dalda, Alberto "ALMA and IRIS Observations of the Solar Chromosphere. II. Structure and Dynamics of Chromospheric Plages" *The Astrophysical Journal*, 906 :83, 2021.
- Chitarra, Olivia; Lee, Kin Long Kelvin; Buchanan, Zachary; Melosso, Mattia; Mcguire, Brett A.; Goubet, Manuel; Pirali, Olivier; Martin-Drumel, Marie-Aline "Hunting the relatives of benzonitrile: Rotational spectroscopy of dicyanobenzenes" *Astronomy and Astrophysics*, 652 :A163, 2021.
- Chomiuk, Laura; Linford, Justin D.; Aydi, Elias; Bannister, Keith W.; Krauss, Miriam I.; Mioduszewski, Amy J.; Mukai, Koji; Nelson, Thomas J.; Rupen, Michael P.; Ryder, Stuart D.; Sokolowski, Jennifer L.; Sokolovsky, Kirill V.; Strader, Jay; Filipović, Miroslav D.; Finzell, Tom; Kawash, Adam; Kool, Erik C.; Metzger, Brian D.; Nyamai, Miriam M.; Ribeiro, Valério A. R. M.; Roy, Nirupam; Urquhart, Ryan; Weston, Jennifer "Classical Novae at Radio Wavelengths" *The Astrophysical Journal Supplement Series*, 257 :49, 2021.
- Choudhury, Spandan; Pineda, Jaime E.; Caselli, Paola; Offner, Stella S. R.; Rosolowsky, Erik; Friesen, Rachel K.; Redaelli, Elena; Chacón-Tanarro, Ana; Shirley, Yancy; Punanova, Anna; Kirk, Helen "Transition from coherent cores to surrounding cloud in L1688" *Astronomy and Astrophysics*, 648 :A114, 2021.
- Chu, Che-Yen; Ng, C.-Y.; Kong, Albert K. H.; Chang, Hsiang-Kuang "High-frequency radio observations of two magnetars, PSR J1622 - 4950 and 1E 1547.0 - 5408" *Monthly Notices of the Royal Astronomical Society*, 503 :1214, 2021.
- Chuang, Chen-Yu; Aso, Yusuke; Hirano, Naomi; Hirano, Shingo; Machida, Masahiro N. "ALMA Observations toward the S-shaped Outflow and the Envelope around NGC 1333 IRAS 4A2" *The Astrophysical Journal*, 916 :82, 2021.
- Cicone, C.; Mainieri, V.; Circosta, C.; Kakkad, D.; Vietri, G.; Perna, M.; Bischetti, M.; Carniani, S.; Cresci, G.; Harrison, C.; Mannucci, F.; Marconi, A.; Piconcelli, E.; Puglisi, A.; Scholtz, J.; Vignali, C.; Zamorani, G.; Zappacosta, L.; Arrigoni Battaia, F. "SUPER. VI. A giant molecular halo around a z = 2 quasar" *Astronomy and Astrophysics*, 654 :L8, 2021.
- Cieza, Lucas A.; González-Ruilova, Camilo; Hales, Antonio S.; Pinilla, Paola; Ruiz-Rodríguez, Dary; Zurlo, Alice; Casassus, Simón; Pérez, Sebastián; Cánovas, Hector; Arce-Tord, Carla; Flock, Mario; Kurtovic, Nicolas; Marino, Sebastian; Nogueira, Pedro H.; Perez, Laura; Price, Daniel J.; Principe, David A.; Williams, Jonathan P. "The Ophiuchus Disc Survey Employing ALMA (ODISEA)-III: the evolution of substructures in massive discs at 3-5 au resolution" *Monthly Notices of the Royal Astronomical Society*, 501 :2934, 2021.
- Ciocan, B. I.; Ziegler, B. L.; Verdugo, M.; Papaderos, P.; Fogarty, K.; Donahue, M.; Postman, M. "The VLT-MUSE and ALMA view of the MACS 1931.8-2635 brightest cluster galaxy" *Astronomy and Astrophysics*, 649 :A23, 2021.
- Circosta, C.; Mainieri, V.; Lamperti, I.; Padovani, P.; Bischetti, M.; Harrison, C. M.; Kakkad, D.; Zanella, A.; Vietri, G.; Lanzuisi, G.; Salvato, M.; Brusa, M.; Carniani, S.; Cicone, C.; Cresci, G.; Feruglio, C.; Husemann, B.; Mannucci, F.; Marconi, A.; Perna, M.; Piconcelli, E.; Puglisi, A.; Saintonge, A.; Schramm, M.; Vignali, C.; Zappacosta, L. "SUPER. IV. CO(J = 3-2) properties of active galactic nucleus hosts at cosmic noon revealed by ALMA" *Astronomy and Astrophysics*, 646 :A96, 2021.
- Cleeves, L. Ilseidore; Loomis, Ryan A.; Teague, Richard; Bergin, Edwin A.; Wilner, David J.; Bergner, Jennifer B.; Blake, Geoffrey A.; Calahan, Jenny K.; Cazzoletti, Paolo; Van Dishoeck, Ewine F.; Guzmán, Viviana V.; Hogerheijde, Michiel R.; Huang, Jane; Kama, Mihkel; Öberg, Karin

- I.; Qi, Chunhua; Van Scheltinga, Jeroen Terwisscha; Walsh, Catherine "The TW Hya Rosetta Stone Project IV: A Hydrocarbon-rich Disk Atmosphere" *The Astrophysical Journal*, 911 :29, 2021.
- Cochrane, R. K.; Best, P. N.; Smail, I.; Ibar, E.; Cheng, C.; Swinbank, A. M.; Molina, J.; Sobral, D.; Dudzevičiūtė, U. "Resolving a dusty, star-forming SH2ZELS galaxy at  $z = 2.2$  with HST, ALMA, and SINFONI on kiloparsec scales" *Monthly Notices of the Royal Astronomical Society*, 503 :2622, 2021.
- Codella, C.; Ceccarelli, C.; Chandler, C.; Sakai, N.; Yamamoto, S.; Faust Team "Enlightening the chemistry of infalling envelopes and accretion disks around Sun-like protostars: the ALMA FAUST project" *Frontiers in Astronomy and Space Sciences*, 8 :227, 2021.
- Cohn, Jonathan H.; Walsh, Jonelle L.; Boizelle, Benjamin D.; Barth, Aaron J.; Gebhardt, Karl; Gültekin, Kayhan; Yıldırım, Akin; Buote, David A.; Darling, Jeremy; Baker, Andrew J.; Ho, Luis C.; Kabasares, Kyle M. "An ALMA Gas-dynamical Mass Measurement of the Supermassive Black Hole in the Local Compact Galaxy UGC 2698" *The Astrophysical Journal*, 919 :77, 2021.
- Colzi, L.; Rivilla, V. M.; Beltrán, M. T.; Jiménez-Serra, I.; Mininni, C.; Melosso, M.; Cesaroni, R.; Fontani, F.; Lorenzani, A.; Sánchez-Monge, A.; Viti, S.; Schilke, P.; Testi, L.; Alonso, E. R.; Kolesníková, L. "The GUAPOS project. II. A comprehensive study of peptide-like bond molecules" *Astronomy and Astrophysics*, 653 :A129, 2021.
- Combes, F.; Gupta, N.; Muller, S.; Balashev, S.; Józsa, G. I. G.; Srikanand, R.; Momjian, E.; Noterdaeme, P.; Klöckner, H.-R.; Baker, A. J.; Boettcher, E.; Bosma, A.; Chen, H.-W.; Dutta, R.; Jagannathan, P.; Jose, J.; Knowles, K.; Krogager, J. - K.; Kulkarni, V. P.; Moodley, K.; Pandey, S.; Petitjean, P.; Sekhar, S. "PKS 1830-211: OH and H I at  $z = 0.89$  and the first MeerKAT UHF spectrum" *Astronomy and Astrophysics*, 648 :A116, 2021.
- Condon, J. J.; Cotton, W. D.; Jarrett, T.; Marchetti, L.; Matthews, A. M.; Mauch, T.; Moloko, M. E. "A MeerKAT 1.28 GHz Atlas of Southern Sources in the IRAS Revised Bright Galaxy Sample" *The Astrophysical Journal Supplement Series*, 257 :35, 2021.
- Condon, J. J.; Cotton, W. D.; White, S. V.; Legodi, S.; Goedhart, S.; Mcalpine, K.; Ratcliffe, S. M.; Camilo, F. "Threads, Ribbons, and Rings in the Radio Galaxy IC 4296" *The Astrophysical Journal*, 917 :18, 2021.
- Connor, Thomas; Bafados, Eduardo; Stern, Daniel; Carilli, Chris; Fabian, Andrew; Momjian, Emmanuel; Rojas-Ruiz, Sofía; Decarli, Roberto; Farina, Emanuele Paolo; Mazzucchelli, Chiara; Earnshaw, Hannah P. "Enhanced X-Ray Emission from the Most Radio-powerful Quasar in the Universe's First Billion Years" *The Astrophysical Journal*, 911 :120, 2021.
- Cook, Jaiden H.; Seymour, Nicholas; Sokolowski, Marcin "A calibration and imaging strategy at 300 MHz with the Murchison Widefield Array (MWA)" *Publications of the Astronomical Society of Australia*, 38 :e063, 2021.
- Cortes, Paulo C.; Le Gouellec, Valentin J. M.; Hull, Charles L. H.; Girart, Josep M.; Louvet, Fabien; Fomalont, Edward B.; Kamenov, Seiji; Moellenbrock, George A.; Nagai, Hiroshi; Nakanishi, Kouichiro; Villard, Eric "The Explosion in Orion-KL as Seen by Mosaicking the Magnetic Field with ALMA" *The Astrophysical Journal*, 907 :94, 2021.
- Cortés, Paulo C.; Sanhueza, Patricio; Houde, Martin; Martín, Sergio; Hull, Charles L. H.; Girart, Josep M.; Zhang, Qizhou; Fernandez-Lopez, Manuel; Zapata, Luis A.; Stephens, Ian W.; Li, Hua-Bai; Wu, Benjamin; Olguin, Fernando; Lu, Xing; Guzmán, Andres E.; Nakamura, Fumitaka "Magnetic Fields in Massive Star-forming Regions (MagMaR). II. Tomography through Dust and Molecular Line Polarization in NGC 6334(N)" *The Astrophysical Journal*, 923 :204, 2021.
- Costa, Allison H.; Johnson, Kelsey E.; Indebetouw, Remy; Finn, Molly K.; Brogan, Crystal L.; Reines, Amy "Toward a More Complex Understanding of Natal Super Star Clusters with Multiwavelength Observations" *The Astrophysical Journal*, 918 :76, 2021.
- Cotton, W. D.; Mauch, T. "Correction of Radio Interferometric Imaging for Antenna Patterns" *Publications of the Astronomical Society of the Pacific*, 133 :104502, 2021.
- Cramer, W. J.; Kenney, J. D. P.; Tonnesen, S.; Smith, R.; Wong, T.; Jáchym, P.; Cortés, J. R.; Cortés, P. C.; Wu, Y.-T. "Molecular Gas Filaments and Fallback in the Ram Pressure Stripped Coma Spiral NGC 4921" *The Astrophysical Journal*, 921 :22, 2021.
- Cronin, Serena A.; Utomo, Dyas; Leroy, Adam K.; Behrens, Erica A.; Chasteney, Jérémy; Holland-Ashford, Tyler; Koch, Eric W.; Lopez, Laura A.; Sandstrom, Karin M.; Williams, Thomas G. "Local Environments of Low-redshift Supernovae" *The Astrophysical Journal*, 923 :86, 2021.
- Cronin-Coltsmann, Patrick F.; Kennedy, Grant M.; Kalas, Paul; Milli, Julien; Clarke, Cathie J.; Duchêne, Gaspard; Greaves, Jane; Lawler, Samantha M.; Lestrade, Jean-François; Matthews, Brenda C.; Shannon, Andrew; Wyatt, Mark C. "ALMA imaging of the M-dwarf Fomalhaut C's debris disc" *Monthly Notices of the Royal Astronomical Society*, 504 :4497, 2021.
- Cruces, M.; Spitler, L. G.; Scholz, P.; Lynch, R.; Seymour, A.; Hessels, J. W. T.; Gouiffés, C.; Hilmarsson, G. H.; Kramer, M.; Munjal, S. "Repeating behaviour of FRB 121102: periodicity, waiting times and energy distribution" *Monthly Notices of the Royal Astronomical Society*, 500 :448, 2021.
- Cuciti, V.; Cassano, R.; Brunetti, G.; Dallacasa, D.; De Gasperin, F.; Etori, S.; Giacintucci, S.; Kale, R.; Pratt, G. W.; Van Weeren, R. J.; Venturi, T. "Radio halos in a mass-selected sample of 75 galaxy clusters. II. Statistical analysis" *Astronomy and Astrophysics*, 647 :A51, 2021.
- Cuciti, V.; Cassano, R.; Brunetti, G.; Dallacasa, D.; Van Weeren, R. J.; Giacintucci, S.; Bonafede, A.; De Gasperin, F.; Etori, S.; Kale, R.; Pratt, G. W.; Venturi, T. "Radio halos in a mass-selected sample of 75 galaxy clusters. I. Sample selection and data analysis" *Astronomy and Astrophysics*, 647 :A50, 2021.
- Cui, Lang; Lu, Ru-Sen; Yu, Wei; Liu, Jun; Patiño-Álvarez, Víctor M.; Yuan, Qi "Resolving the inner jet of PKS 1749+096 with super-resolution VLBA images at 7 mm" *Research in Astronomy and Astrophysics*, 21 :91, 2021.
- Czekala, Ian; Loomis, Ryan A.; Teague, Richard; Booth, Alice S.; Huang, Jane; Cataldi, Gianni; Ilee, John D.; Law, Charles J.; Walsh, Catherine; Bosman, Arthur D.; Guzmán, Viviana V.; Gal, Romane Le; Öberg, Karin I.; Yamato, Yoshihide; Aikawa, Yuri; Andrews, Sean M.; Bae, Jaehan; Bergin, Edwin A.; Bergner, Jennifer B.; Cleaves, L. Ilse; Kurtovic, Nicolas T.; Ménard, François; Nomura, Hideko; Pérez, Laura M.; Qi, Chunhua; Schwarz, Kamber R.; Tsukagoshi, Takashi; Waggoner, Abigail R.; Wilner, David J.; Zhang, Ke "Molecules with ALMA at Planet-forming Scales (MAPS). II. CLEAN Strategies for Synthesizing Images of Molecular Line Emission in Protoplanetary Disks" *The Astrophysical Journal Supplement Series*, 257 :2, 2021.
- Czekala, Ian; Ribas, Álvaro; Cuello, Nicolás; Chiang, Eugene; Macías, Enrique; Duchêne, Gaspard; Andrews, Sean M.; Espaillat, Catherine C. "A Coplanar Circumbinary Protoplanetary Disk in the TWA 3 Triple M Dwarf System" *The Astrophysical Journal*, 912 :6, 2021.
- Da Cunha, E.; Hodge, J. A.; Casey, C. M.; Algera, H. S. B.; Kaasinen, M.; Smail, I.; Walter, F.; Brandt, W. N.; Dannerbauer, H.; Decarli, R.; Groves, B. A.; Knudsen, K. K.; Swinbank, A. M.; Weiss, A.; Van Der Werf, P.; Zavala, J. A. "Measurements of the Dust Properties in  $z = 1-3$  Submillimeter Galaxies with ALMA" *The Astrophysical Journal*, 919 :30, 2021.
- Dabbech, A.; Repetti, A.; Perley, R. A.; Smirnov, O. M.; Wiaux, Y. "Cygnus A jointly calibrated and imaged via non-convex optimisation from VLA data" *Monthly Notices of the Royal Astronomical Society*, 506 :4855, 2021.
- Daddi, E.; Valentino, F.; Rich, R. M.; Neill, J. D.; Gronke, M.; O'Sullivan, D.; Elbaz, D.; Bournaud, F.; Finoguenov, A.; Marchal, A.; Delvecchio, I.; Jin, S.; Liu, D.; Strazzullo, V.; Calabro, A.; Coogan, R.; D'Eugenio, C.; Gobat, R.; Kalita, B. S.; Laursen, P.; Martin, D. C.; Puglisi, A.; Schinnerer, E.; Wang, T. "Three Lyman- $\alpha$ -emitting filaments converging to a massive galaxy group at  $z = 2.91$ : discussing the case for cold gas infall" *Astronomy and Astrophysics*, 649 :A78, 2021.
- Dallacasa, D.; Orienti, M.; Fanti, C.; Fanti, R. "VLBI images at 327 MHz of compact steep spectrum and GHz-peaked spectrum sources from

## APPENDIX A: PUBLICATIONS

- the 3C and PW samples" *Monthly Notices of the Royal Astronomical Society*, 504 :2312, 2021.
- D'Amato, Quirino; Prandoni, Isabella; Brienza, Marisa; Gilli, Roberto; Vignali, Cristian; Paladino, Rosita; Loi, Francesca; Massardi, Marcella; Mignoli, Marco; Marchesi, Stefano; Peca, Alessandro; Jagannathan, Preshanth "Multi-Wavelength Study of a Proto-BCG at  $z = 1.7$ " *Galaxies*, 9 :115, 2021.
- Danilovich, T.; Van De Sande, M.; Plane, J. M. C.; Millar, T. J.; Royer, P.; Amor, M. A.; Hammami, K.; Decock, L.; Gottlieb, C. A.; Decin, L.; Richards, A. M. S.; De Beck, E.; Baudry, A.; Bolte, J.; Cannon, E.; De Ceuster, F.; De Koter, A.; Etoka, S.; Gobrecht, D.; Gray, M.; Herpin, F.; Homan, W.; Jeste, M.; Kervella, P.; Khouri, T.; Lagadec, E.; Maes, S.; Malfait, J.; McDonald, I.; Menten, K. M.; Montargès, M.; Müller, H. S. P.; Pimpanuwat, B.; Sahai, R.; Wallström, S. H. J.; Waters, L. B. F. M.; Wong, K. T.; Yates, J.; Zijlstra, A. "ATOMIUM: halide molecules around the S-type AGB star W Aquilae" *Astronomy and Astrophysics*, 655 :A80, 2021.
- Das, Barnali; Chandra, Poonam "Ultra-wideband, Multiepoch Radio Study of the First Discovered "Main-sequence Radio Pulse Emitter" CU Vir" *The Astrophysical Journal*, 921 :9, 2021.
- Das, Kaustav K.; Sankharva, Kishan; Jain, Pankaj "Explaining excess dipole in NVSS data using superhorizon perturbation" *Journal of Cosmology and Astro-Particle Physics*, 2021 :35, 2021.
- Das, S.; Kharb, P.; Morganti, R.; Nandi, S. "The peculiar WAT NGC 2329 with Seyfert/FR I-like radio lobes" *Monthly Notices of the Royal Astronomical Society*, 504 :4416, 2021.
- Davis, A. Bianca; Nierenberg, Anna M.; Peter, Annika H. G.; Garling, Christopher T.; Greco, Johnny P.; Kochanek, Christopher S.; Utomo, Dyas; Casey, Kirsten J.; Pogge, Richard W.; Roberts, Daniella M.; Sand, David J.; Sardone, Amy "The LBT satellites of Nearby Galaxies Survey (LBT-SONG): the satellite population of NGC 628" *Monthly Notices of the Royal Astronomical Society*, 500 :3854, 2021.
- De Gasperin, F.; Williams, W. L.; Best, P.; Brügger, M.; Brunetti, G.; Cuciti, V.; Dijkema, T. J.; Hardcastle, M. J.; Norden, M. J.; Offringa, A.; Shimwell, T.; Van Weeren, R.; Bomans, D.; Bonafede, A.; Botteon, A.; Callingham, J. R.; Cassano, R.; Chyży, K. T.; Emig, K. L.; Edler, H.; Haverkorn, M.; Heald, G.; Heesen, V.; Iacobelli, M.; Intema, H. T.; Kadler, M.; Malek, K.; Mevius, M.; Miley, G.; Mingo, B.; Morabito, L. K.; Sabater, J.; Morganti, R.; Orrú, E.; Pizzo, R.; Prandoni, I.; Shulevski, A.; Tasse, C.; Vaccari, M.; Zarka, P.; Röttgering, H. "The LOFAR LBA Sky Survey. I. Survey description and preliminary data release" *Astronomy and Astrophysics*, 648 :A104, 2021.
- De Haas, S. E. M.; Russell, T. D.; Degenaar, N.; Markoff, S.; Tetarenko, A. J.; Tetarenko, B. E.; Van Den Eijnden, J.; Miller-Jones, J. C. A.; Parikh, A. S.; Plotkin, R. M.; Sivakoff, G. R. "Disc-jet coupling changes as a possible indicator for outbursts from GX 339-4 remaining within the X-ray hard state" *Monthly Notices of the Royal Astronomical Society*, 502 :521, 2021.
- De Kleer, Katherine; Butler, Bryan; De Pater, Imke; Gurwell, Mark A.; Moullet, Arielle; Trumbo, Samantha; Spencer, John "Ganymede's Surface Properties from Millimeter and Infrared Thermal Emission" *The Planetary Science Journal*, 2 :20 pp, 2021.
- De Kleer, Katherine; Cambioni, Saverio; Shepard, Michael "The Surface of (16) Psyche from Thermal Emission and Polarization Mapping" *The Planetary Science Journal*, 2 :149, 2021.
- Delhaize, J.; Heywood, I.; Prescott, M.; Jarvis, M. J.; Delvecchio, I.; Whittam, I. H.; White, S. V.; Hardcastle, M. J.; Hale, C. L.; Afonso, J.; Ao, Y.; Brienza, M.; Brügger, M.; Collier, J. D.; Daddi, E.; Glowacki, M.; Maddox, N.; Morabito, L. K.; Prandoni, I.; Randriamanakoto, Z.; Sekhar, S.; An, Fangxia; Adams, N. J.; Blyth, S.; Bowler, R. A. A.; Leeuw, L.; Marchetti, L.; Randriamampandry, S. M.; Thorat, K.; Seymour, N.; Smirnov, O.; Taylor, A. R.; Tasse, C.; Vaccari, M. "MIGHTEE: are giant radio galaxies more common than we thought?" *Monthly Notices of the Royal Astronomical Society*, 501 :3833, 2021.
- Della Bruna, Lorenza; Adamo, Angela; Lee, Janice C.; Smith, Linda J.; Krumholz, Mark; Bik, Arjan; Calzetti, Daniela; Fox, Anne; Fumagalli, Michele; Grasha, Kathryn; Messa, Matteo; Östlin, Göran; Walterbos, Rene; Wofford, Aida "Studying the ISM at  $10 \text{ pc}$  scale in NGC 7793 with MUSE. II. Constraints on the oxygen abundance and ionising radiation escape" *Astronomy and Astrophysics*, 650 :A103, 2021.
- Delvecchio, I.; Daddi, E.; Sargent, M. T.; Jarvis, M. J.; Elbaz, D.; Jin, S.; Liu, D.; Whittam, I. H.; Algera, H.; Carraro, R.; D'Eugenio, C.; Delhaize, J.; Kalita, B. S.; Leslie, S.; Molnár, D. Cs.; Novak, M.; Prandoni, I.; Smolčić, V.; Ao, Y.; Aravena, M.; Bournaud, F.; Collier, J. D.; Randriamampandry, S. M.; Randriamanakoto, Z.; Rodighiero, G.; Schober, J.; White, S. V.; Zamorani, G. "The infrared-radio correlation of star-forming galaxies is strongly M -dependent but nearly redshift-invariant since  $z = 4$ " *Astronomy and Astrophysics*, 647 :A123, 2021.
- Den Brok, J. S.; Chatzigiannakis, D.; Bigiel, F.; Puschniig, J.; Barnes, A. T.; Leroy, A. K.; Jiménez-Donaire, M. J.; Usero, A.; Schinnerer, E.; Rosolowsky, E.; Faesi, C. M.; Grasha, K.; Hughes, A.; Krujissen, J. M. D.; Liu, D.; Neumann, L.; Pety, J.; Querejeta, M.; Saito, T.; Schrubba, A.; Stuber, S. "New constraints on the  $12\text{CO}(2-1)/(1-0)$  line ratio across nearby disc galaxies" *Monthly Notices of the Royal Astronomical Society*, 504 :3221, 2021.
- Deneva, J. S.; Ray, P. S.; Camilo, F.; Freire, P. C. C.; Cromartie, H. T.; Ransom, S. M.; Ferrara, E.; Kerr, M.; Burnett, T. H.; Parkinson, P. M. Saz "Timing of Eight Binary Millisecond Pulsars Found with Arecibo in Fermi-LAT Unidentified Sources" *The Astrophysical Journal*, 909 :6, 2021.
- Devin, J.; Renaud, M.; Lemoine-Goumard, M.; Vasileiadis, G. "Multiwavelength constraints on the unidentified Galactic TeV sources HESS J1427-608, HESS J1458-608, and new VHE  $\gamma$ -ray source candidates" *Astronomy and Astrophysics*, 647 :A68, 2021.
- Dewangan, L. K. "Unraveling the inner substructure of new candidate hub-filament system in the H II region G25.4NW" *Monthly Notices of the Royal Astronomical Society*, 504 :1152, 2021.
- Dewangan, L. K.; Dhanya, J. S.; Bhadari, N. K.; Ojha, D. K.; Baug, T. "Lynds Bright Nebulae: sites of possible twisted filaments and ongoing star formation" *Monthly Notices of the Royal Astronomical Society*, 506 :6081, 2021.
- Dhanya, Jayakumar Sushama; Dewangan, Lokesh Kumar; Ojha, Devendra Kumar; Mandal, Subhayan "New insights in giant molecular cloud hosting the S147/S153 complex: signatures of interacting clouds" *Publications of the Astronomical Society of Japan*, 73 :S355, 2021.
- Di Gennaro, G.; Van Weeren, R. J.; Cassano, R.; Brunetti, G.; Brügger, M.; Hoeft, M.; Osinga, E.; Botteon, A.; Cuciti, V.; De Gasperin, F.; Röttgering, H. J. A.; Tasse, C. "A LOFAR-uGMRT spectral index study of distant radio halos" *Astronomy and Astrophysics*, 654 :A166, 2021.
- Di Gennaro, G.; Van Weeren, R. J.; Rudnick, L.; Hoeft, M.; Brügger, M.; Ryu, Dongsu; Röttgering, H. J. A.; Forman, W.; Stroe, A.; Shimwell, T. W.; Kraft, R. P.; Jones, C.; Hoang, D. N. "Downstream Depolarization in the Sausage Relic: A 1-4 GHz Very Large Array Study" *The Astrophysical Journal*, 911 :3, 2021.
- Di Gennaro, Gabriella; Van Weeren, Reinout J.; Brunetti, Gianfranco; Cassano, Rossella; Brügger, Marcus; Hoeft, Matthias; Shimwell, Timothy W.; Röttgering, Huub J. A.; Bonafede, Annalisa; Botteon, Andrea; Cuciti, Virginia; Dallacasa, Daniele; De Gasperin, Francesco; Domínguez-Fernández, Paola; Enßlin, Torsten A.; Gastaldello, Fabio; Mandal, Soumyajit; Rossetti, Mariachiara; Simionescu, Aurora "Fast magnetic field amplification in distant galaxy clusters" *Nature Astronomy*, 5 :268, 2021.
- Di Mascolo, Luca; Mroczkowski, Tony; Perrott, Yvette; Rudnick, Lawrence; James Jee, M.; Hyeonghan, Kim; Churazov, Eugene; Collier, Jordan D.; Diego, Jose M.; Hopkins, Andrew M.; Kim, Jinhyub; Koribalski, Bärbel S.; Marvil, Joshua D.; Van Der Burg, Remco; West, Jennifer L. "Multiwavelength view of SPT-CL J2106-5844. The radio galaxies and the thermal and relativistic plasmas in a massive galaxy cluster merger at  $z = 1.13$ " *Astronomy and Astrophysics*, 650 :A153, 2021.
- Diamantidis, Periklis-Konstantinos; Klopotek, Grzegorz; Haas, Rüdiger "VLBI



- and GPS inter- and intra-technique combinations on the observation level for evaluation of TRF and EOP" *Earth, Planets, and Space*, 73 :68, 2021.
- Diamond-Stanic, Aleksandar M.; Moustakas, John; Sell, Paul H.; Tremonti, Christy A.; Coil, Allison L.; Davis, Julie D.; Geach, James E.; Gottlieb, Sophia C. W.; Hickox, Ryan C.; Kepley, Amanda; Lipscomb, Charles; Rines, Joshua; Rudnick, Gregory H.; Thompson, Christopher; Valdez, Kingdell; Bradna, Christian; Camarillo, Jordan; Cinquino, Eve; Ohene, Senyo; Perrotta, Serena; Petter, Grayson C.; Rupke, David S. N.; Umeh, Chidubem; Whalen, Kelly E. "Compact Starburst Galaxies with Fast Outflows: Central Escape Velocities and Stellar Mass Surface Densities from Multiband Hubble Space Telescope Imaging" *The Astrophysical Journal*, 912 :11, 2021.
- Diaz Trigo, M.; Petry, D.; Humphreys, E.; Impellizzeri, C. M. V.; Liu, H. B. "A search for signatures of interactions of X-ray binary outflows with their environments with ALMA" *Astronomy and Astrophysics*, 650 :A37, 2021.
- Diaz-Santos, Tanio; Assef, Roberto J.; Eisenhardt, Peter R. M.; Jun, Hyunsung D.; Jones, Gareth C.; Blain, Andrew W.; Stern, Daniel; Aravena, Manuel; Tsai, Chao-Wei; Lake, Sean E.; Wu, Jingwen; González-López, Jorge "Kinematics and star formation of high-redshift hot dust-obscured quasars as seen by ALMA" *Astronomy and Astrophysics*, 654 :A37, 2021.
- Dib, Sami; Braine, Jonathan; Gopinathan, Maheswar; Lara-López, Maritza A.; Kravtsov, Valery V.; Soam, Archana; Sharma, Ekta; Zhukovska, Svitlana; Aouad, Charles; Belinchón, José Antonio; Helou, George; Li, Di "The structure and characteristic scales of the H I gas in galactic disks" *Astronomy and Astrophysics*, 655 :A101, 2021.
- Dicker, Simon R.; Battistelli, Elia S.; Bhandarkar, Tanay; Devlin, Mark J.; Duff, Shannon M.; Hilton, Gene; Hilton, Matt; Hincks, Adam D.; Hubmayr, Johannes; Huppenberger, Kevin; Hughes, John P.; Mascolo, Luca Di; Mason, Brian S.; Mates, J. A. B.; McMahon, Jeff; Mroczkowski, Tony; Naess, Sigurd; Orłowski-Scherer, John; Partridge, Bruce; Radiconi, Federico; Romero, Charles; Sarazin, Craig L.; Sehgal, Neelima; Sievers, Jonathan; Sifón, Cristóbal; Ullom, Joel; Vale, Leila R.; Vissers, Michael R.; Xu, Zhilei "Observations of compact sources in galaxy clusters using MUSTANG2" *Monthly Notices of the Royal Astronomical Society*, 2107 :, 2021.
- Dike, V.; Morris, M. R.; Rich, R. M.; Lewis, M. O.; Quiroga-Nuñez, L. H.; Stroh, M. C.; Trapp, A. C.; Claussen, M. J. "Ground Vibrational State SiO Emission in the VLA BAaDE Survey" *The Astronomical Journal*, 161 :111, 2021.
- Ding, Hao; Deller, Adam T.; Fonseca, Emmanuel; Stairs, Ingrid H.; Stappers, Benjamin; Lyne, Andrew "The Orbital-decay Test of General Relativity to the 2% Level with 6 yr VLBA Astrometry of the Double Neutron Star PSR J1537+1155" *The Astrophysical Journal*, 921 :L19, 2021.
- Doi, Kiyoaki; Kataoka, Akimasa "Estimate on Dust Scale Height from the ALMA Dust Continuum Image of the HD 163296 Protoplanetary Disk" *The Astrophysical Journal*, 912 :164, 2021.
- Dokara, R.; Brunthaler, A.; Menten, K. M.; Dzib, S. A.; Reich, W.; Cotton, W. D.; Anderson, L. D.; Chen, C.-H. R.; Gong, Y.; Medina, S.-N. X.; Ortiz-León, G. N.; Rugel, M.; Urquhart, J. S.; Wyrowski, F.; Yang, A. Y.; Beuther, H.; Billington, S. J.; Csengeri, T.; Carrasco-González, C.; Roy, N. "A global view on star formation: The GLOSTAR Galactic plane survey. II. Supernova remnants in the first quadrant of the Milky Way" *Astronomy and Astrophysics*, 651 :A86, 2021.
- Dolch, Timothy; Stinebring, Dan R.; Jones, Glenn; Zhu, Hengrui; Lynch, Ryan S.; Cohen, Tyler; Demorest, Paul B.; Lam, Michael T.; Levin, Lina; Mclaughlin, Maura A.; Palliyaguru, Nipuni T. "Deconvolving Pulsar Signals with Cyclic Spectroscopy: A Systematic Evaluation" *The Astrophysical Journal*, 913 :98, 2021.
- Dominik, Rune M.; Linhoff, Lena; Elsässer, Dominik; Rhode, Wolfgang "3C 84: a possibly precessing jet in 43-GHz observations" *Monthly Notices of the Royal Astronomical Society*, 503 :5448, 2021.
- Dong, D. Z.; Hallinan, G.; Nakar, E.; Ho, A. Y. Q.; Hughes, A. K.; Hotokezaka, K.; Myers, S. T.; De, K.; Mooley, K. P.; Ravi, V.; Horesh, A.; Kasliwal, M. M.; Kulkarni, S. R. "A transient radio source consistent with a merger-triggered core collapse supernova" *Science*, 373 :1125, 2021.
- Drouart, Guillaume; Seymour, Nick; Broderick, Jess W.; Afonso, José; Chhetri, Rajan; De Breuck, Carlos; Emonts, Bjorn; Galvin, Tim J.; Lehnert, Matthew D.; Morgan, John; Stern, Daniel; Vernet, Joël; Wright, Nigel "The nature and likely redshift of GLEAM J0917-0012" *Publications of the Astronomical Society of Australia*, 38 :e049, 2021.
- Dudzevičiūtė, U.; Smail, Ian; Swinbank, A. M.; Lim, C.-F.; Wang, W.-H.; Simpson, J. M.; Ao, Y.; Chapman, S. C.; Chen, C.-C.; Clements, D.; Dannerbauer, H.; Ho, L. C.; Hwang, H. S.; Koprowski, M.; Lee, C.-H.; Scott, D.; Shim, H.; Shirley, R.; Toba, Y. "Tracing the evolution of dust-obscured activity using sub-millimetre galaxy populations from STUDIES and AS2UDS" *Monthly Notices of the Royal Astronomical Society*, 500 :942, 2021.
- Dunne, Delaney A.; Webb, Tracy M. A.; Noble, Allison; Lidman, Christopher; Shipley, Heath; Muzzin, Adam; Wilson, Gillian; Yee, H. K. C. "A CO Survey of SpARCS Star-forming Brightest Cluster Galaxies: Evidence for Uniformity in BCG Molecular Gas Processing across Cosmic Time" *The Astrophysical Journal*, 909 :L29, 2021.
- Dunne, L.; Maddox, S. J.; Vlahakis, C.; Gomez, H. L. "Dust continuum, CO and [C I] 1-0 lines: Self-consistent H<sub>2</sub> mass estimates and the possibility of globally CO-'dark' galaxies at z=0.35" *Monthly Notices of the Royal Astronomical Society*, 501 :pp.2573-2607, 2021.
- Dupuy, A.; Courtois, H. M.; Guinet, D.; Tully, R. B.; Kourkchi, E. "Toward Cosmiflows-4: The HI data catalog" *Astronomy and Astrophysics*, 646 :A113, 2021.
- Dzib, Sergio A.; Forbrich, Jan; Reid, Mark J.; Menten, Karl M. "A VLBA Survey of Radio Stars in the Orion Nebula Cluster. II. Astrometry" *The Astrophysical Journal*, 906 :24, 2021.
- Dzib, Sergio A.; Rodríguez, Luis F. "Radio Proper Motions of the Energetic Pulsar PSR J1813-1749" *The Astrophysical Journal*, 923 :228, 2021.
- Džudžar, Robert; Kilborn, Virginia; Sweet, Sarah M.; Meurer, Gerhardt; Jarrett, T. H.; Kleiner, Dane "Environmental processing of galaxies in H I-rich groups" *Monthly Notices of the Royal Astronomical Society*, 500 :3689, 2021.
- Eftekhari, T.; Margalit, B.; Omand, C. M. B.; Berger, E.; Blanchard, P. K.; Demorest, P.; Metzger, B. D.; Murase, K.; Nicholl, M.; Villar, V. A.; Williams, P. K. G.; Alexander, K. D.; Chatterjee, S.; Coppejans, D. L.; Cordes, J. M.; Gomez, S.; Hosseinzadeh, G.; Hsu, B.; Kashiwama, K.; Margutti, R.; Yin, Y. "Late-time Radio and Millimeter Observations of Superluminous Supernovae and Long Gamma-Ray Bursts: Implications for Central Engines, Fast Radio Bursts, and Obscured Star Formation" *The Astrophysical Journal*, 912 :21, 2021.
- Egorov, Oleg V.; Lozinskaya, Tatiana A.; Vasiliev, Konstantin I.; Yarovova, Anastasiya D.; Gerasimov, Ivan S.; Kreckel, Kathryn; Moiseev, Alexei V. "Star formation in the nearby dwarf galaxy DDO 53: interplay between gas accretion and stellar feedback" *Monthly Notices of the Royal Astronomical Society*, 508 :2650, 2021.
- Egron, Elise; Pellizzoni, Alberto; Righini, Simona; Giroletti, Marcello; Koljonen, Karri; Pottschmidt, Katja; Trushkin, Sergei; Lobina, Jessica; Pilia, Maura; Wilms, Joern; Corbel, Stéphane; Grinberg, Victoria; Loru, Sara; Trois, Alessio; Rodriguez, Jérôme; Lähteenmäki, A.; Tornikoski, M.; Eneštam, S.; Järvelä, E. "Investigating the Mini and Giant Radio Flare Episodes of Cygnus X-3" *The Astrophysical Journal*, 906 :10, 2021.
- Eht Mwi Science Working Group; Algaba, J. C.; Anczarski, J.; Asada, K.; Baloković, M.; Chandra, S.; Cui, Y.-Z.; Falcone, A. D.; Giroletti, M.; Goddi, C.; Hada, K.; Haggard, D.; Jorstad, S.; Kaur, A.; Kawashima, T.; Keating, G.; Kim, J.-Y.; Kino, M.; Komossa, S.; Kravchenko, E. V.; Krichbaum, T. P.; Lee, S.-S.; Lu, R.-S.; Lucchini, M.; Markoff, S.; Neilsen, J.; Nowak, M. A.; Park, J.; Principe, G.; Ramakrishnan, V.; Reynolds, M. T.; Sasada, M.; Savchenko, S. S.; Williamson, K. E.; Event Horizon Telescope Collaboration; Akiyama, Kazunori; Anthoni, Alef; Walter; Anantua, Richard; Azulay, Rebecca; Baczko, Anne-Kathrin; Ball, David;

## APPENDIX A: PUBLICATIONS

- Barrett, John; Bintley, Dan; Benson, Bradford A.; Blackburn, Lindy; Blundell, Raymond; Boland, Wilfred; Bouman, Katherine L.; Bower, Geoffrey C.; Boyce, Hope; Bremer, Michael; Brinkerink, Christiaan D.; Brissenden, Roger; Britzen, Silke; Broderick, Avery E.; Brogiere, Dominique; Bronzwaer, Thomas; Byun, Do-Young; Carlstrom, John E.; Chael, Andrew; Chan, Chi-Kwan; Chatterjee, Shami; Chatterjee, Koushik; Chen, Ming-Tang; Chen, Yongjun; Chesler, Paul M.; Cho, Ilje; Christian, Pierre; Conway, John E.; Cordes, James M.; Crawford, Thomas M.; Crew, Geoffrey B.; Cruz-Osorio, Alejandro; Davelaar, Jordy; De Laurentis, Mariafelicia; Deane, Roger; Dempsey, Jessica; Desvignes, Gregory; Dexter, Jason; Doleman, Sheperd S.; Eatough, Ralph P.; Falcke, Heino; Farah, Joseph; Fish, Vincent L.; Fomalont, Ed; Ford, H. Alyson; Fraga-Encinas, Raquel; Friberg, Per; Fromm, Christian M.; Fuentes, Antonio; Galison, Peter; Gammie, Charles F.; García, Roberto; Gentaz, Olivier; Georgiev, Boris; Gold, Roman; Gómez, José L.; Gómez-Ruiz, Arturo I.; Gu, Minfeng; Gurwell, Mark; Hecht, Michael H.; Hesper, Ronald; Ho, Luis C.; Ho, Paul; Honma, Mareki; Huang, Chih-Wei L.; Huang, Lei; Hughes, David H.; Ikeda, Shiro; Inoue, Makoto; Issaoun, Sara; James, David J.; Jannuzi, Buell T.; Janssen, Michael; Jeter, Britton; Jiang, Wu; Jiménez-Rosales, Alejandra; Johnson, Michael D.; Jung, Taehyun; Karami, Mansour; Karuppusamy, Ramesh; Kettenis, Mark; Kim, Dong-Jin; Kim, Jongsoo; Kim, Junhan; Koay, Jun Yi; Kofuji, Yutaro; Koch, Patrick M.; Koyama, Shoko; Kramer, Michael; Kramer, Carsten; Kuo, Cheng-Yu; Lauer, Tod R.; Levis, Aviad; Li, Yan-Rong; Li, Zhiyuan; Lindqvist, Michael; Lico, Rocco; Lindahl, Greg; Liu, Jun; Liu, Kuo; Liuzzo, Elisabetta; Lo, Wen-Ping; Lobanov, Andrei P.; Loinard, Laurent; Lonsdale, Colin; Macdonald, Nicholas R.; Mao, Jirong; Marchili, Nicola; Marrone, Daniel P.; Marscher, Alan P.; Martí-Vidal, Iván; Matsushita, Satoki; Matthews, Lynn D.; Medeiros, Lia; Menten, Karl M.; Mizuno, Izumi; Mizuno, Yosuke; Moran, James M.; Moriyama, Kotaro; Moscibrodzka, Monika; Müller, Cornelia; Musoke, Gibwa; Mejías, Alejandro Mus; Nagai, Hiroshi; Nagar, Neil M.; Nakamura, Masanori; Narayan, Ramesh; Narayanan, Gopal; Natarajan, Iniyar; Nathanail, Antonios; Neri, Roberto; Ni, Chunhong; Noutsos, Aristeidis; Okino, Hiroki; Olivares, Héctor; Ortiz-León, Gisela N.; Oyama, Tomoaki; Özel, Feryal; Palumbo, Daniel C. M.; Patel, Nimesh; Pen, Ue-Li; Pesce, Dominic W.; Piétu, Vincent; Plambeck, Richard; Popstefanija, Aleksandar; Porth, Oliver; Pötzl, Felix M.; Prather, Ben; Preciado-López, Jorge A.; Psaltis, Dimitrios; Pu, Hung-Yi; Rao, Ramprasad; Rawlings, Mark G.; Raymond, Alexander W.; Rezzolla, Luciano; Ricarte, Angelo; Ripperda, Bart; Roelofs, Freek; Rogers, Alan; Ros, Eduardo; Rose, Mel; Roshaninshat, Arash; Rottmann, Helge; Roy, Alan L.; Ruszczyk, Chet; Rygl, Kazi L. J.; Sánchez, Salvador; Sánchez-Arguelles, David; Savolainen, Tuomas; Schloerb, F. Peter; Schuster, Karl-Friedrich; Shao, Lijing; Shen, Zhiqiang; Small, Des; Sohn, Bong Won; Soohoo, Jason; Sun, He; Tazaki, Fumie; Tetarenko, Alexandra J.; Tiede, Paul; Tilanus, Remo P. J.; Titus, Michael; Toma, Kenji; Torne, Pablo; Trent, Tyler; Traianou, Efthalia; Trippe, Sascha; Van Bemmelen, Ilse; Van Langevelde, Huib Jan; Van Rossum, Daniel R.; Wagner, Jan; Ward-Thompson, Derek; Wardle, John; Weintraub, Jonathan; Wex, Norbert; Wharton, Robert; Wielgus, Maciek; Wong, George N.; Wu, Qingwen; Yoon, Doosoo; Young, André; Young, Ken; Younsi, Ziri; Yuan, Feng; Yuan, Ye-Fei; Zensus, J. Anton; Zhao, Guang-Yao; Zhao, Shan-Shan; Fermi Large Area Telescope Collaboration; Principe, G.; Giroletti, M.; D'Ammando, F.; Orienti, M.; H. E. S. S. Collaboration; Abdalla, H.; Adam, R.; Aharonian, F.; Benkhali, F. Ait; Angüner, E. O.; Arcaro, C.; Armand, C.; Armstrong, T.; Ashkar, H.; Backes, M.; Baghmanyan, V.; Barbosa Martins, V.; Barnacka, A.; Barnard, M.; Becherini, Y.; Berge, D.; Bernlöhr, K.; Bi, B.; Böttcher, M.; Boisson, C.; Bolmont, J.; De Lavernge, M. De Bony; Breuhaus, M.; Brun, F.; Brun, P.; Bryan, M.; Büchele, M.; Bulik, T.; Bylund, T.; Caroff, S.; Carosi, A.; Casanova, S.; Chand, T.; Chen, A.; Cotter, G.; Curylo, M.; Damascene Mbarubucyeye, J.; Davids, I. D.; Davies, J.; Deil, C.; Devin, J.; Dewilt, P.; Dirson, L.; Djannati-Ataï, A.; Dmytriev, A.; Donath, A.; Doroshenko, V.; Duffy, C.; Dyks, J.; Egberts, K.; Eichhorn, F.; Einecke, S.; Emery, G.; Ernenwein, J.-P.; Feijen, K.; Fegan, S.; Fiascon, A.; De Clairfontaine, G. Fichet; Fontaine, G.; Funk, S.; Füßling, M.; Gabici, S.; Gallant, Y. A.; Giavitto, G.; Giunti, L.; Glawion, D.; Glicenstein, J. F.; Gottschall, D.; Grondin, M.-H.; Hahn, J.; Haupt, M.; Hermann, G.; Hinton, J. A.; Hofmann, W.; Hoischen, C.; Holch, T. L.; Holler, M.; Hörbe, M.; Horns, D.; Huber, D.; Jamroz, M.; Jankowsky, D.; Jankowsky, F.; Jardin-Blicq, A.; Joshi, V.; Jung-Richardt, I.; Kasai, E.; Kastendieck, M. A.; Katarzyński, K.; Katz, U.; Khangulyan, D.; Khélifi, B.; Klepser, S.; Kluzniak, W.; Komin, Nu.; Konno, R.; Kosack, K.; Kostunin, D.; Kreter, M.; Lamanna, G.; Lemièrre, A.; Lemoine-Goumard, M.; Lenain, J.-P.; Levy, C.; Lohse, T.; Lypova, I.; Mackey, J.; Majumdar, J.; Malyshev, D.; Malyshev, D.; Marandon, V.; Marchegiani, P.; Marcowith, A.; Mares, A.; Martí-Devesa, G.; Marx, R.; Maurin, G.; Meintjes, P. J.; Meyer, M.; Moderski, R.; Mohamed, M.; Mohrmann, L.; Montanari, A.; Moore, C.; Morris, P.; Moulin, E.; Muller, J.; Murach, T.; Nakashima, K.; Nayerhoda, A.; De Naurais, M.; Ndiyavala, H.; Niederwanger, F.; Niemi, J.; Oakes, L.; O'Brien, P.; Odaka, H.; Ohm, S.; Olivera-Nieto, L.; De Ona Wilhelmi, E.; Ostrowski, M.; Panter, M.; Panny, S.; Parsons, R. D.; Peron, G.; Peyaud, B.; Piel, Q.; Pita, S.; Poireau, V.; Noel, A. Priyana; Prokhorov, D. A.; Prokoph, H.; Pühlhofer, G.; Punch, M.; Quirrenbach, A.; Rauth, R.; Reichherzer, P.; Reimer, A.; Reimer, O.; Remy, G.; Renaud, M.; Rieger, F.; Rinchiuso, L.; Romoli, C.; Rowell, G.; Rudak, B.; Ruiz-Velasco, E.; Sahakian, V.; Sailer, S.; Sanchez, D. A.; Santangelo, A.; Sasaki, M.; Scalici, M.; Schutte, H. M.; Schwanke, U.; Schwemmer, S.; Seglar-Arroyo, M.; Senniappan, M.; Seyffert, A. S.; Shafi, N.; Shiningayamwe, K.; Simoni, R.; Sinha, A.; Sol, H.; Specovius, A.; Spencer, S.; Spir-Jacob, M.; Stawarz, Ł.; Sun, L.; Steenkamp, R.; Stegmann, C.; Steinmassl, S.; Steppa, C.; Takahashi, T.; Tavernier, T.; Taylor, A. M.; Terrier, R.; Tiziani, D.; Tluczykont, M.; Tomankova, L.; Trichard, C.; Tsirou, M.; Tuffs, R.; Uchiyama, Y.; Van Der Walt, D. J.; Van Eldik, C.; Van Rensburg, C.; Van Soelen, B.; Vasileiadis, G.; Veh, J.; Venter, C.; Vincent, P.; Vink, J.; Völk, H. J.; Vuillaume, T.; Wadiasingh, Z.; Wagner, S. J.; Watson, J.; Werner, F.; White, R.; Wiercholska, A.; Wong, Yu Wun; Yusufzai, A.; Zacharias, M.; Zanin, R.; Zargaryan, D.; Zdziarski, A. A.; Zech, A.; Zhu, S. J.; Zorn, J.; Zouari, S.; Żywucka, N.; Magic Collaboration; Acciari, V. A.; Ansoldi, S.; Antonelli, L. A.; Engels, A. Arbet; Artero, M.; Asano, K.; Baack, D.; Babić, A.; Baquero, A.; De Almeida, U. Barres; Barrio, J. A.; Becerra González, J.; Bednarek, W.; Bellizzi, L.; Bernardini, E.; Bernardos, M.; Bertl, A.; Besenrieder, J.; Bhattacharyya, W.; Bigongiari, C.; Biland, A.; Blanch, O.; Bonnoli, G.; Bošnjak, Ž.; Busetto, G.; Carosi, R.; Ceribella, G.; Cerruti, M.; Chai, Y.; Chilingarian, A.; Cikota, S.; Colak, S. M.; Colombo, C.; Contreras, J. L.; Cortina, J.; Covino, S.; D'Amico, G.; D'Elia, V.; Da Vela, P.; Dazzi, F.; De Angelis, A.; De Lotto, B.; Delfino, M.; Delgado, J.; Delgado Mendez, C.; Depaoli, D.; Di Pierro, F.; Di Venere, L.; Do Souto Espiñeira, E.; Dominis Prester, D.; Donini, A.; Dorner, D.; Doro, M.; Elsaesser, D.; Ramazani, V. Fallah; Fattorini, A.; Ferrara, G.; Fonseca, M. V.; Font, L.; Fruck, C.; Fukami, S.; García López, R. J.; Garczarczyk, M.; Gasparyan, S.; Gaug, M.; Giglietto, N.; Giordano, F.; Gliwny, P.; Godinović, N.; Green, J. G.; Green, D.; Hadasch, D.; Hahn, A.; Heckmann, L.; Herrera, J.; Hoang, J.; Hrupec, D.; Hütten, M.; Inada, T.; Inoue, S.; Ishio, K.; Iwamura, Y.; Jiménez, I.; Jormanainen, J.; Jouvin, L.; Kajiwara, Y.; Karjalainen, M.; Kerszberg, D.; Kobayashi, Y.; Kubo, H.; Kushida, J.; Lamastra, A.; Lelas, D.; Leone, F.; Lindfors, E.; Lombardi, S.; Longo, F.; López-Coto, R.; López-Moya, M.; López-Oramas, A.; Loporchio, S.; Machado De Oliveira Fraga, B.; Maggio, C.; Majumdar, P.; Makariev, M.; Mallamaci, M.; Maneva, G.; Manganaro, M.; Mannheim, K.; Maraschi, L.; Mariotti, M.; Martínez, M.; Mazin, D.; Menchiarì, S.; Mender, S.; Mićanović, S.; Miceli, D.; Miener, T.; Mineev, M.; Miranda, J. M.; Mirzoyan, R.; Molina, E.; Moralejo, A.; Morcuende, D.; Moreno, V.; Moretti, E.; Neustroev, V.; Nigro, C.; Nilsson, K.; Nishijima, K.; Noda, K.; Nozaki, S.; Ohtani, Y.; Oka, T.; Otero-Santos, J.; Paiano, S.; Palatiello, M.; Paneque, D.; Paoletti, R.; Paredes, J. M.; Pavletić, L.; Peñil, P.; Perennes, C.; Persic, M.; Moroni, P. G. Prada; Prandini, E.; Priyadarshi, C.; Puljak, I.; Rhode, W.; Ribó, M.; Rico, J.; Righi, C.; Rugliancich, A.; Saha, L.; Sahakyan, N.;

- Saito, T.; Sakurai, S.; Satalecka, K.; Saturni, F. G.; Schleicher, B.; Schmidt, K.; Schweizer, T.; Sitarek, J.; Šnidarić, I.; Sobczynska, D.; Spolon, A.; Stammer, A.; Strom, D.; Strzys, M.; Suda, Y.; Suric, T.; Takahashi, M.; Tavecchio, F.; Temnikov, P.; Terzić, T.; Teshima, M.; Tosti, L.; Truzzi, S.; Tutone, A.; Ubach, S.; Van Scherpenberg, J.; Vanzo, G.; Vazquez Acosta, M.; Ventura, S.; Verguillo, V.; Vigorito, C. F.; Vitale, V.; Vovk, I.; Will, M.; Wunderlich, C.; Zarić, D.; Veritas Collaboration; Adams, C. B.; Benbow, W.; Brill, A.; Capasso, M.; Christiansen, J. L.; Chromey, A. J.; Daniel, M. K.; Errando, M.; Farrell, K. A.; Feng, Q.; Finley, J. P.; Fortson, L.; Furniss, A.; Gent, A.; Giuri, C.; Hassan, T.; Hervet, O.; Holder, J.; Hughes, G.; Humensky, T. B.; Jin, W.; Kaaret, P.; Kertzman, M.; Kieda, D.; Kumar, S.; Lang, M. J.; Lundy, M.; Maier, G.; Moriarty, P.; Mukherjee, R.; Nieto, D.; Nievas-Rosillo, M.; O'Brien, S.; Ong, R. A.; Otte, A. N.; Patel, S.; Pfrang, K.; Pohl, M.; Prado, R. R.; Puschel, E.; Quinn, J.; Ragan, K.; Reynolds, P. T.; Ribeiro, D.; Richards, G. T.; Roache, E.; Rulten, C.; Ryan, J. L.; Santander, M.; Sembroski, G. H.; Shang, R.; Weinstein, A.; Williams, D. A.; Williamson, T. J.; Eavn Collaboration; Hirota, Tomoya; Cui, Lang; Niinuma, Kotaro; Ro, Hyunwook; Sakai, Nobuyuki; Sawada-Satoh, Satoko; Wajima, Kiyooki; Wang, Na; Liu, Xiang; Yonekura, Yoshinori "Broadband Multi-wavelength Properties of M87 during the 2017 Event Horizon Telescope Campaign" *The Astrophysical Journal*, 911 :L11, 2021.
- Elison, Sara L.; Lin, Lihwai; Thorp, Mallory D.; Pan, Hsi-An; Sánchez, Sebastian F.; Bluck, Asa F. L.; Belfiore, Francesco "The ALMaQUEST survey - VI. The molecular gas main sequence of 'retired' regions in galaxies" *Monthly Notices of the Royal Astronomical Society*, 502 :L6, 2021.
- Elison, Sara L.; Lin, Lihwai; Thorp, Mallory D.; Pan, Hsi-An; Scudder, Jillian M.; Sánchez, Sebastian F.; Bluck, Asa F. L.; Maiolino, Roberto "The ALMaQUEST Survey - V. The non-universality of kpc-scale star formation relations and the factors that drive them" *Monthly Notices of the Royal Astronomical Society*, 501 :4777, 2021.
- Ecalada, Frankie J.; Looney, Leslie W.; Tobin, John J.; Sadavoy, Sarah I.; Segura-Cox, Dominique; Cox, Erin; Li, Zhi-Yun; Novak, Giles "870  $\mu$ m Dust Continuum of the Youngest Protostars in Ophiuchus" *The Astrophysical Journal*, 913 :149, 2021.
- Endres, Christian P.; Martin-Drumel, Marie-Aline; Zingsheim, Oliver; Bonah, Luis; Pirali, Olivier; Zhang ( ), Tianwei; Sánchez-Monge, Álvaro; Möller, Thomas; Wehres, Nadine; Schilke, Peter; Mccarthy, Michael C.; Schlemmer, Stephan; Caselli, Paola; Thorwirth, Sven "SOLEIL and ALMA views on prototypical organic nitriles: C2H5CN" *Journal of Molecular Spectroscopy*, 375 :11392, 2021.
- Etemadfard, Hossein; Heinkelmann, Robert; Hossainali, Masoud Mashhadi; Schuh, Harald "The Role of Spatial Gradient on Vertical Total Electron Content Extraction From Geodetic Very Long Baseline Interferometry Observation: Case Study CONT08 to CONT17-L1" *Space Weather*, 19 :e02633, 2021.
- Event Horizon Telescope Collaboration; Akiyama, Kazunori; Algaba, Juan Carlos; Alberdi, Antxon; Alef, Walter; Anantua, Richard; Asada, Keiichi; Azulay, Rebecca; Baczko, Anne-Kathrin; Ball, David; Baloković, Mislav; Barrett, John; Benson, Bradford A.; Bintley, Dan; Blackburn, Lindy; Blundell, Raymond; Boland, Wilfred; Bouman, Katherine L.; Bower, Geoffrey C.; Boyce, Hope; Bremer, Michael; Brinkerink, Christiaan D.; Brissenden, Roger; Britzen, Silke; Broderick, Avery E.; Brogiere, Dominique; Bronzwaer, Thomas; Byun, Do-Young; Carlstrom, John E.; Chael, Andrew; Chan, Chi-Kwan; Chatterjee, Shami; Chatterjee, Koushik; Chen, Ming-Tang; Chen, Yongjun; Chesler, Paul M.; Cho, Ilje; Christian, Pierre; Conway, John E.; Cordes, James M.; Crawford, Thomas M.; Crew, Geoffrey B.; Cruz-Osorio, Alejandro; Cui, Yuzhu; Davelaar, Jordy; De Laurentis, Mariafelicia; Deane, Roger; Dempsey, Jessica; Desvignes, Gregory; Dexter, Jason; Doleman, Sheperd S.; Eatough, Ralph P.; Falcke, Heino; Farah, Joseph; Fish, Vincent L.; Fomalont, Ed; Ford, H. Alyson; Fraga-Encinas, Raquel; Freeman, William T.; Friberg, Per; Fromm, Christian M.; Fuentes, Antonio; Galison, Charles F.; García, Roberto; Gelles, Zachary; Gentaz, Olivier; Georgiev, Boris; Gammie, Charles F.; García, Roberto; Gentaz, Olivier; Georgiev, Arturo I.; Gu, Minfeng; Gurwell, Mark; Hada, Kazuhiro; Haggard, Daryl; Hecht, Michael H.; Hesper, Ronald; Ho, Luis C.; Ho, Paul; Honma, Mareki; Huang, Chih-Wei L.; Huang, Lei; Hughes, David H.; Ikeda, Shiro; Inoue, Makoto; Issaoun, Sara; James, David J.; Jannuzi, Buell T.; Janssen, Michael; Jeter, Britton; Jiang, Wu; Jimenez-Rosales, Alejandra; Johnson, Michael D.; Jorstad, Svetlana; Jung, Tae-hyun; Karami, Mansour; Karuppusamy, Ramesh; Kawashima, Tomohisa; Keating, Garrett K.; Kettenis, Mark; Kim, Dong-Jin; Kim, Jae-Young; Kim, Jongsoo; Kim, Junhan; Kino, Motoki; Koay, Jun Yi; Kofuji, Yutaro; Koch, Patrick M.; Koyama, Shoko; Kramer, Michael; Kramer, Carsten; Krichbaum, Thomas P.; Kuo, Cheng-Yu; Lauer, Tod R.; Lee, Sang-Sung; Levis, Aviad; Li, Yan-Rong; Li, Zhiyuan; Lindqvist, Michael; Lico, Rocco; Lindahl, Greg; Liu, Jun; Liu, Kuo; Liuzzo, Elisabetta; Lo, Wen-Ping; Lobanov, Andrei P.; Loinard, Laurent; Lonsdale, Colin; Lu, Ru-Sen; Macdonald, Nicholas R.; Mao, Jirong; Marchili, Nicola; Markoff, Sera; Marrone, Daniel P.; Marscher, Alan P.; Martí-Vidal, Iván; Matsushita, Satoki; Matthews, Lynn D.; Medeiros, Lia; Menten, Karl M.; Mizuno, Izumi; Mizuno, Yosuke; Moran, James M.; Moriyama, Kotaro; Moscibrodzka, Monika; Müller, Cornelia; Musoke, Gibwa; Mejías, Alejandro Mus; Michalik, Daniel; Nadolski, Andrew; Nagai, Hiroshi; Nagar, Neil M.; Nakamura, Masanori; Narayan, Ramesh; Narayanan, Gopal; Natarajan, Iniyana; Nathanail, Antonios; Neilsen, Joey; Neri, Roberto; Ni, Chunhong; Noutsos, Aristeidis; Nowak, Michael A.; Okino, Hiroki; Olivares, Héctor; Ortiz-León, Gisela N.; Oyama, Tomoaki; Özel, Feryal; Palumbo, Daniel C. M.; Park, Jongho; Patel, Nimesh; Pen, Ue-Li; Pesce, Dominic W.; Piétu, Vincent; Plambeck, Richard; Popstefanija, Aleksandar; Porth, Oliver; Pötzl, Felix M.; Prather, Ben; Preciado-López, Jorge A.; Psaltis, Dimitrios; Pu, Hung-Yi; Ramakrishnan, Venkatesh; Rao, Ramprasad; Rawlings, Mark G.; Raymond, Alexander W.; Rezzolla, Luciano; Ricarte, Angelo; Ripperda, Bart; Roelofs, Freek; Rogers, Alan; Ros, Eduardo; Rose, Mel; Roshanineshat, Arash; Rottmann, Helge; Roy, Alan L.; Ruszczyk, Chet; Rygl, Kazi L. J.; Sánchez, Salvador; Sánchez-Argüelles, David; Sasada, Mahito; Savolainen, Tuomas; Schloerb, F. Peter; Schuster, Karl-Friedrich; Shao, Lijing; Shen, Zhiqiang; Small, Des; Sohn, Bong Won; Soohoo, Jason; Sun, He; Tazaki, Fumie; Tetarenko, Alexandra J.; Tiede, Paul; Tilanus, Remo P. J.; Titus, Michael; Toma, Kenji; Torne, Pablo; Trent, Tyler; Traianou, Ethalia; Trippe, Sascha; Van Bemmelen, Ilse; Van Langevelde, Huib Jan; Van Rossum, Daniel R.; Wagner, Jan; Ward-Thompson, Derek; Wardle, John; Weintraub, Jonathan; Wex, Norbert; Wharton, Robert; Wielgos, Maciej; Wong, George N.; Wu, Qingwen; Yoon, Doosoo; Young, André; Young, Ken; Younsi, Ziri; Yuan, Feng; Yuan, Ye-Fei; Zensus, J. Anton; Zhao, Guang-Yao; Zhao, Shan-Shan "First M87 Event Horizon Telescope Results. VII. Polarization of the Ring" *The Astrophysical Journal*, 910 :L12, 2021.
- Event Horizon Telescope Collaboration; Akiyama, Kazunori; Algaba, Juan Carlos; Alberdi, Antxon; Alef, Walter; Anantua, Richard; Asada, Keiichi; Azulay, Rebecca; Baczko, Anne-Kathrin; Ball, David; Baloković, Mislav; Barrett, John; Benson, Bradford A.; Bintley, Dan; Blackburn, Lindy; Blundell, Raymond; Boland, Wilfred; Bouman, Katherine L.; Bower, Geoffrey C.; Boyce, Hope; Bremer, Michael; Brinkerink, Christiaan D.; Brissenden, Roger; Britzen, Silke; Broderick, Avery E.; Brogiere, Dominique; Bronzwaer, Thomas; Byun, Do-Young; Carlstrom, John E.; Chael, Andrew; Chan, Chi-Kwan; Chatterjee, Shami; Chatterjee, Koushik; Chen, Ming-Tang; Chen, Yongjun; Chesler, Paul M.; Cho, Ilje; Christian, Pierre; Conway, John E.; Cordes, James M.; Crawford, Thomas M.; Crew, Geoffrey B.; Cruz-Osorio, Alejandro; Cui, Yuzhu; Davelaar, Jordy; De Laurentis, Mariafelicia; Deane, Roger; Dempsey, Jessica; Desvignes, Gregory; Dexter, Jason; Doleman, Sheperd S.; Eatough, Ralph P.; Falcke, Heino; Farah, Joseph; Fish, Vincent L.; Fomalont, Ed; Ford, H. Alyson; Fraga-Encinas, Raquel; Friberg, Per; Fromm, Christian M.; Fuentes, Antonio; Galison, Charles F.; Gammie, Charles F.; García, Roberto; Gelles, Zachary; Gentaz, Olivier; Georgiev,

## APPENDIX A: PUBLICATIONS

- Boris; Goddi, Ciriaco; Gold, Roman; Gómez, José L.; Gómez-Ruiz, Arturo I.; Gu, Minfeng; Gurwell, Mark; Hada, Kazuhiro; Haggard, Daryl; Hecht, Michael H.; Hesper, Ronald; Himwich, Elizabeth; Ho, Luis C.; Ho, Paul; Honma, Mareki; Huang, Chih-Wei L.; Huang, Lei; Hughes, David H.; Ikeda, Shiro; Inoue, Makoto; Issaoun, Sara; James, David J.; Jannuzi, Buell T.; Janssen, Michael; Jeter, Britton; Jiang, Wu; Jimenez-Rosales, Alejandra; Johnson, Michael D.; Jorstad, Svetlana; Jung, Taehyun; Karami, Mansour; Karuppusamy, Ramesh; Kawashima, Tomohisa; Keating, Garrett K.; Kettenis, Mark; Kim, Dong-Jin; Kim, Jae-Young; Kim, Jongsoo; Kim, Junhan; Kino, Motoki; Koay, Jun Yi; Kofuji, Yutaro; Koch, Patrick M.; Koyama, Shoko; Kramer, Michael; Kramer, Carsten; Krichbaum, Thomas P.; Kuo, Cheng-Yu; Lauer, Tod R.; Lee, Sang-Sung; Levis, Aviad; Li, Yan-Rong; Li, Zhiyuan; Lindqvist, Michael; Lico, Rocco; Lindahl, Greg; Liu, Jun; Liu, Kuo; Luzzo, Elisabetta; Lo, Wen-Ping; Lobanov, Andrei P.; Loinard, Laurent; Lonsdale, Colin; Lu, Ru-Sen; Macdonald, Nicholas R.; Mao, Jirong; Marchili, Nicola; Markoff, Sera; Marrone, Daniel P.; Marscher, Alan P.; Martí-Vidal, Iván; Matsushita, Satoki; Matthews, Lynn D.; Medeiros, Lia; Menten, Karl M.; Mizuno, Izumi; Mizuno, Yosuke; Moran, James M.; Moriyama, Kotaro; Moscibrodzka, Monika; Müller, Cornelia; Musoke, Gibwa; Mus Mejías, Alejandro; Michalik, Daniel; Nadolski, Andrew; Nagai, Hiroshi; Nagar, Neil M.; Nakamura, Masanori; Narayan, Ramesh; Narayanan, Gopal; Natarajan, Iniyani; Nathanael, Antonios; Neilsen, Joey; Neri, Roberto; Ni, Chunrong; Noutsos, Aristeidis; Nowak, Michael A.; Okino, Hiroki; Olivares, Héctor; Ortiz-León, Gisela N.; Oyama, Tomoaki; Özel, Feryal; Palumbo, Daniel C. M.; Park, Jongho; Patel, Nimesh; Pen, Ue-Li; Pesce, Dominic W.; Piétu, Vincent; Plambeck, Richard; Popstefanija, Aleksandar; Porth, Oliver; Pötzl, Felix M.; Prather, Ben; Preciado-López, Jorge A.; Psaltis, Dimitrios; Pu, Hung-Yi; Ramakrishnan, Venkatesh; Rao, Ramprasad; Rawlings, Mark G.; Raymond, Alexander W.; Rezzolla, Luciano; Ricarte, Angelo; Ripperda, Bart; Roelofs, Freek; Rogers, Alan; Ros, Eduardo; Rose, Mel; Roshanineshat, Arash; Rottmann, Helge; Roy, Alan L.; Ruzszyk, Chet; Rygl, Kazi L. J.; Sánchez, Salvador; Sánchez-Argüelles, David; Sasada, Mahito; Savolainen, Tuomas; Schloerb, F. Peter; Schuster, Karl-Friedrich; Shao, Lijing; Shen, Zhiqiang; Small, Des; Sohn, Bong Won; Soohoo, Jason; Sun, He; Tazaki, Fumie; Tetarenko, Alexandra J.; Tiede, Paul; Tilanus, Remo P. J.; Titus, Michael; Toma, Kenji; Torne, Pablo; Trent, Tyler; Traianou, Efthalia; Trippe, Sascha; Van Bemmell, Ilse; Van Langevelde, Huib Jan; Van Rossum, Daniel R.; Wagner, Jan; Ward-Thompson, Derek; Wardle, John; Weintraub, Jonathan; Wex, Norbert; Wharton, Robert; Wielgus, Maciek; Wong, George N.; Wu, Qingwen; Yoon, Doosoo; Young, André; Young, Ken; Younsi, Ziri; Yuan, Feng; Yuan, Ye-Fei; Zensus, J. Anton; Zhao, Guang-Yao; Zhao, Shan-Shan "First M87 Event Horizon Telescope Results. VIII. Magnetic Field Structure near The Event Horizon" *The Astrophysical Journal*, 910 :L13, 2021.
- Facchini, Stefano; Teague, Richard; Bae, Jaehan; Benisty, Myriam; Kepler, Miriam; Isella, Andrea "The Chemical Inventory of the Planet-hosting Disk PDS 70" *The Astronomical Journal*, 162 :99, 2021.
- Fadda, Dario; Laine, Seppo; Appleton, Philip N. "[C II] and CO Emission along the Bar and Counter-arms of NGC 7479" *The Astrophysical Journal*, 909 :204, 2021.
- Fagnoni, Nicolas; De Lera Acedo, Eloy; Deboer, David R.; Abdurashidova, Zara; Aguirre, James E.; Alexander, Paul; Ali, Zaki S.; Balfour, Yanga; Beardsley, Adam P.; Bernardi, Gianni; Billings, Tashalee S.; Bowman, Judd D.; Bradley, Richard F.; Bull, Phil; Burba, Jacob; Carilli, Chris L.; Cheng, Carina; Dexter, Matt; Dillon, Joshua S.; Ewall-Wice, Aaron; Fritz, Randall; Furlanetto, Steve R.; Gale-Sides, Kingsley; Glendenning, Brian; Gorthi, Deepthi; Greig, Bradley; Grobbelaar, Jasper; Halday, Ziyad; Hazelton, Bryna J.; Hewitt, Jacqueline N.; Hickish, Jack; Jacobs, Daniel C.; Josaitis, Alec; Julius, Austin; Kern, Nicholas S.; Kerrigan, Joshua; Kim, Honggeun; Kittiwisit, Piyanat; Kohn, Saul A.; Kolopanis, Matthew; Lanman, Adam; La Plante, Paul; Lekalake, Telalo; Liu, Adrian; Macmahon, David; Malan, Lourence; Malgas, Cresshim; Maree, Matthys; Martinot, Zachary E.; Matsetela, Eunice; Mena Parra, Juan; Mesinger, Andrei; Molewa, Mathakane; Morales, Miguel F.; Mosiane, Tsegofalanga; Neben, Abraham R.; Nikolic, Bojan; Parsons, Aaron R.; Patra, Nipanjana; Pieterse, Samantha; Pober, Jonathan C.; Razavi-Ghods, Nima; Robnett, James; Rosie, Kathryn; Sims, Peter; Smith, Craig; Syce, Angelo; Thyagarajan, Nithyanandan; Williams, Peter K. G.; Zheng, Haoxuan "Understanding the HERA Phase I receiver system with simulations and its impact on the detectability of the EoR delay power spectrum" *Monthly Notices of the Royal Astronomical Society*, 500 :1232, 2021.
- Falkendal, Theresa; Lehnert, Matthew D.; Vernet, Joël; De Breuck, Carlos; Wang, Wuji "ALMA and MUSE observations reveal a quiescent multi-phase circumgalactic medium around the z = 3.6 radio galaxy 4C 19.71" *Astronomy and Astrophysics*, 645 :A120, 2021.
- Falstad, N.; Aalto, S.; König, S.; Onishi, K.; Müller, S.; Gorski, M.; Sato, M.; Stanley, F.; Combes, F.; González-Alfonso, E.; Mangum, J. G.; Evans, A. S.; Barcos-Muñoz, L.; Privo, G. C.; Linden, S. T.; Díaz-Santos, T.; Martín, S.; Sakamoto, K.; Harada, N.; Fuller, G. A.; Gallagher, J. S.; Van Der Werf, P. P.; Viti, S.; Greve, T. R.; García-Burillo, S.; Henkel, C.; Imanishi, M.; Izumi, T.; Nishimura, Y.; Ricci, C.; Mühle, S. "CON-quest. Searching for the most obscured galaxy nuclei" *Astronomy and Astrophysics*, 649 :A105, 2021.
- Faramaz, Virginie; Marino, Sebastian; Booth, Mark; Matrà, Luca; Mamajek, Eric E.; Bryden, Geoffrey; Stapelfeldt, Karl R.; Casassus, Simon; Cuadra, Jorge; Hales, Antonio S.; Zurlo, Alice "A Detailed Characterization of HR 8799's Debris Disk with ALMA in Band 7" *The Astronomical Journal*, 161 :271, 2021.
- Farren, Gerrit S.; Partridge, Bruce; Kneissl, Rüdiger; Aiola, Simone; Datta, Rahul; Gralla, Megan; Li, Yaogong "Confirming the Calibration of ALMA Using Planck Observations" *The Astrophysical Journal Supplement Series*, 256 :19, 2021.
- Fatigoni, S.; Radiconi, F.; Battistelli, E. S.; Murgia, M.; Carretti, E.; Castangia, P.; Concu, R.; De Bernardis, P.; Fritz, J.; Genova-Santos, R.; Govoni, F.; Guidi, F.; Lamagna, L.; Masi, S.; Melis, A.; Paladini, R.; Perez-Toledo, F. M.; Piacentini, F.; Poppi, S.; Rebolo, R.; Rubino-Martin, J. A.; Surcis, G.; Tarchi, A.; Vacca, V. "Study of the thermal and nonthermal emission components in M 31: the Sardinia Radio Telescope view at 6.6 GHz" *Astronomy and Astrophysics*, 651 :A98, 2021.
- Fawcett, Victoria A.; Alexander, David M.; Rosario, David J.; Klindt, Lizelke "How Are Red and Blue Quasars Different? The Radio Properties" *Galaxies*, 9 :107, 2021.
- Fedele, D.; Toci, C.; Maud, L.; Lodato, G. "ALMA 870  $\mu\text{m}$  continuum observations of HD 100546. Evidence of a giant planet on a wide orbit" *Astronomy and Astrophysics*, 651 :A90, 2021.
- Feeney-Johansson, A.; Purser, S. J. D.; Ray, T. P.; Vidotto, A. A.; Eislöffel, J.; Callingham, J. R.; Shimwell, T. W.; Vedantham, H. K.; Hallinan, G.; Tasse, C. "Detection of coherent low-frequency radio bursts from weak-line T Tauri stars" *Astronomy and Astrophysics*, 653 :A101, 2021.
- Fernández-López, M.; Sanhueza, P.; Zapata, L. A.; Stephens, I.; Hull, C.; Zhang, Q.; Girart, J. M.; Koch, P. M.; Cortés, P.; Silva, A.; Tatematsu, K.; Nakamura, F.; Guzmán, A. E.; Nguyen Luong, Q.; Guzmán Ccolque, E.; Tang, Y.-W.; Chen, H. -R. V. "Magnetic Fields in Massive Star-forming Regions (MagMaR). I. Linear Polarized Imaging of the Ultracompact H II Region G5.89-0.39" *The Astrophysical Journal*, 913 :29, 2021.
- Fernández-Ontiveros, Juan A.; Muñoz-Darias, Teo "X-ray binary accretion states in active galactic nuclei? Sensing the accretion disc of supermassive black holes with mid-infrared nebular lines" *Monthly Notices of the Royal Astronomical Society*, 504 :5726, 2021.
- Ferris, E. R.; Blain, A. W.; Assef, R. J.; Hatch, N. A.; Kimball, A.; Kim, M.; Sajina, A.; Silva, A.; Stern, D.; Diaz-Santos, T.; Tsai, C.-W.; Wylezalek, D. "The black hole masses of extremely luminous radio-WISE selected galaxies" *Monthly Notices of the Royal Astronomical Society*, 502 :1527, 2021.
- Filipović, M. D.; Bojčić, I. S.; Grieve, K. R.; Norris, R. P.; Tothill, N. F. H.;

- Shobhana, D.; Rudnick, L.; Prandoni, I.; Andernach, H.; Hurley-Walker, N.; Alsaber, R. Z. E.; Anderson, C. S.; Collier, J. D.; Crawford, E. J.; For, B.-Q.; Galvin, T. J.; Haberl, F.; Hopkins, A. M.; Ingallinera, A.; Kavanagh, P. J.; Koribalski, B. S.; Kothes, R.; Leahy, D.; Leverenz, H.; Maggi, P.; Maitra, C.; Marvil, J.; Pannuti, T. G.; Park, L. A. F.; Payne, J. L.; Pennock, C. M.; Riggi, S.; Rowell, G.; Sano, H.; Sasaki, M.; Staveley-Smith, L.; Triguero, C.; Umama, G.; Urošević, D.; Van Loon, J. Th.; Vardoulaki, E. "Radio continuum sources behind the Large Magellanic Cloud" *Monthly Notices of the Royal Astronomical Society*, 507 :2885, 2021.
- Finn, Molly K.; Indebetouw, Remy; Johnson, Kelsey E.; Costa, Allison H.; Chen, C.-H. Rosie; Kawamura, Akiko; Onishi, Toshikazu; Ott, Jürgen; Tokuda, Kazuki; Wong, Tony; Zahorec, Sarolta "Physical Conditions in the LMC's Quiescent Molecular Ridge: Fitting Non-LTE Models to CO Emission" *The Astrophysical Journal*, 917 :106, 2021.
- Fischer, Travis C.; Secrest, Nathan J.; Johnson, Megan C.; Dorland, Bryan N.; Cigan, Phillip J.; Fernandez, Luis C.; Hunt, Lucas R.; Koss, Michael; Schmitt, Henrique R.; Zacharias, Norbert "Fundamental Reference AGN Monitoring Experiment (FRAMEx). I. Jumping Out of the Plane with the VLBA" *The Astrophysical Journal*, 906 :88, 2021.
- Flores, C.; Duchêne, G.; Wolff, S.; Villenave, M.; Stapelfeldt, K.; Williams, J. P.; Pinte, C.; Padgett, D.; Connelley, M. S.; Van Der Plas, G.; Ménard, F.; Perrin, M. D. "The Anatomy of an Unusual Edge-on Protoplanetary Disk. II. Gas Temperature and a Warm Outer Region" *The Astronomical Journal*, 161 :239, 2021.
- Florez, Jonathan; Berlind, Andreas A.; Kannappan, Sheila J.; Stark, David V.; Eckert, Kathleen D.; Calderon, Victor F.; Moffett, Amanda J.; Campbell, Duncan; Sinha, Manodeep "Void Galaxies Follow a Distinct Evolutionary Path in the Environmental COntext Catalog" *The Astrophysical Journal*, 906 :97, 2021.
- Fogasy, Judit; Knudsen, K. K.; Drouart, G.; Gullberg, B. "ALMA detects molecular gas in the halo of the powerful radio galaxy TXS 0828+193" *Monthly Notices of the Royal Astronomical Society*, 501 :5973, 2021.
- Fong, W.; Laskar, T.; Rastinejad, J.; Escorial, A. Rouco; Schroeder, G.; Barnes, J.; Kilpatrick, C. D.; Paterson, K.; Berger, E.; Metzger, B. D.; Dong, Y.; Nugent, A. E.; Strausbaugh, R.; Blanchard, P. K.; Goyal, A.; Cucchiara, A.; Terreran, G.; Alexander, K. D.; Eftekhari, T.; Fryer, C.; Margalit, B.; Margutti, R.; Nicholl, M. "The Broadband Counterpart of the Short GRB 200522A at  $z = 0.5536$ : A Luminous Kilonova or a Collimated Outflow with a Reverse Shock?" *The Astrophysical Journal*, 906 :127, 2021.
- Fong, Wen-Fai; Dong, Yuxin; Leja, Joel; Bhandari, Shivani; Day, Cherie K.; Deller, Adam T.; Kumar, Pravir; Prochaska, J. Xavier; Scott, Danica R.; Bannister, Keith W.; Eftekhari, Tarraneh; Gordon, Alexa C.; Heintz, Kasper E.; James, Clancy W.; Kilpatrick, Charles D.; Mahony, Elizabeth K.; Rouco Escorial, Alicia; Ryder, Stuart D.; Shannon, Ryan M.; Tejos, Nicolas "Chronically the Host Galaxy Properties of the Remarkable Repeating FRB 20201124A" *The Astrophysical Journal*, 919 :L23, 2021.
- Fonseca, E.; Cromartie, H. T.; Pennucci, T. T.; Ray, P. S.; Kirichenko, A. Yu.; Ransom, S. M.; Demorest, P. B.; Stairs, I. H.; Arzoumanian, Z.; Guillemot, L.; Parthasarathy, A.; Kerr, M.; Cognard, I.; Baker, P. T.; Blumer, H.; Brook, P. R.; Decesar, M.; Dolch, T.; Dong, F. A.; Ferrara, E. C.; Fiore, W.; Garver-Daniels, N.; Good, D. C.; Jennings, R.; Jones, M. L.; Kaspi, V. M.; Lam, M. T.; Lorimer, D. R.; Luo, J.; McEwen, A.; Mckee, J. W.; McLaughlin, M. A.; Mckinnon, N.; Meyers, B. W.; Naidu, A.; Ng, C.; Nice, D. J.; Pol, N.; Radovan, H. A.; Shapiro-Albert, B.; Tan, C. M.; Tendulkar, S. P.; Swiggum, J. K.; Wahl, H. M.; Zhu, W. W. "Refined Mass and Geometric Measurements of the High-mass PSR J0740+6620" *The Astrophysical Journal*, 915 :L12, 2021.
- Fontani, F.; Barnes, A. T.; Caselli, P.; Henshaw, J. D.; Cosentino, G.; Jiménez-Serra, I.; Tan, J. C.; Pineda, J. E.; Law, C. Y. "ALMA-IRDC - II. First high-angular resolution measurements of the  $^{14}\text{N}/^{15}\text{N}$  ratio in a large sample of infrared-dark cloud cores" *Monthly Notices of the Royal Astronomical Society*, 503 :4320, 2021.
- Forbrich, Jan; Dzib, Sergio A.; Reid, Mark J.; Menten, Karl M. "A VLBA Survey of Radio Stars in the Orion Nebula Cluster. I. The Nonthermal Radio Population" *The Astrophysical Journal*, 906 :23, 2021.
- Franco, M.; Coppin, K. E. K.; Geach, J. E.; Kobayashi, C.; Chapman, S. C.; Yang, C.; González-Alfonso, E.; Spilker, J. S.; Cooray, A.; Michałowski, M. J. "The ramp-up of interstellar medium enrichment at  $z > 4$ " *Nature Astronomy*, 5 :1240, 2021.
- Franzen, T. M. O.; Hurley-Walker, N.; White, S. V.; Hancock, P. J.; Seymour, N.; Kapińska, A. D.; Staveley-Smith, L.; Wayth, R. B. "Galactic and Extragalactic All-sky Murchison Widefield Array (GLEAM) survey III: South Galactic Pole data release" *Publications of the Astronomical Society of Australia*, 38 :e014, 2021.
- Franzen, T. M. O.; Seymour, N.; Sadler, E. M.; Mauch, T.; White, S. V.; Jackson, C. A.; Chhetri, R.; Quici, B.; Bell, M. E.; Callingham, J. R.; Dwarakanath, K. S.; For, B.; Gaensler, B. M.; Hancock, P. J.; Hindson, L.; Hurley-Walker, N.; Johnston-Hollitt, M.; Kapińska, A. D.; Lenc, E.; McKinley, B.; Morgan, J.; Offringa, A. R.; Procopio, P.; Staveley-Smith, L.; Wayth, R. B.; Wu, C.; Zheng, Q. "The GLEAM 200-MHz local radio luminosity function for AGN and star-forming galaxies" *Publications of the Astronomical Society of Australia*, 38 :e041, 2021.
- Fraternali, F.; Karim, A.; Magnelli, B.; Gómez-Guijarro, C.; Jiménez-Andrade, E. F.; Poses, A. C. "Fast rotating and low-turbulence discs at  $z \sim 4.5$ : Dynamical evidence of their evolution into local early-type galaxies" *Astronomy and Astrophysics*, 647 :A194, 2021.
- Fu, Hai; Xue, R.; Prochaska, J. X.; Stockton, A.; Ponnada, S.; Lau, M. W.; Cooray, A.; Narayanan, D. "A Long Stream of Metal-poor Cool Gas around a Massive Starburst Galaxy at  $z = 2.67$ " *The Astrophysical Journal*, 908 :188, 2021.
- Fudamoto, Y.; Oesch, P. A.; Schouws, S.; Stefanon, M.; Smit, R.; Bouwens, R. J.; Bowler, R. A. A.; Endsley, R.; Gonzalez, V.; Inami, H.; Labbe, I.; Stark, D.; Aravena, M.; Barrufet, L.; Da Cunha, E.; Dayal, P.; Ferrara, A.; Graziani, L.; Hodge, J.; Hutter, A.; Li, Y.; De Looze, I.; Nanayakkara, T.; Pallottini, A.; Riechers, D.; Schneider, R.; Ucci, G.; Van Der Werf, P.; White, C. "Normal, dust-obscured galaxies in the epoch of reionization" *Nature*, 597 :489, 2021.
- Fuente, A.; Treviño-Morales, S. P.; Alonso-Albi, T.; Sánchez-Monge, A.; Rivière-Marichalar, P.; Navarro-Almolda, D. "Probing the kinematics and chemistry of the hot core Mon R2 IRS 3 using ALMA observations" *Monthly Notices of the Royal Astronomical Society*, 507 :1886, 2021.
- Fujimoto, Seiji; Oguri, Masamune; Brammer, Gabriel; Yoshimura, Yuki; Laporte, Nicolas; González-López, Jorge; Caminha, Gabriel B.; Kohno, Kotaro; Zitrin, Adi; Richard, Johan; Ouchi, Masami; Bauer, Franz E.; Smail, Ian; Hatsukade, Bunyo; Ono, Yoshiaki; Kokorev, Vasily; Umehata, Hideki; Schaerer, Daniel; Knudsen, Kirsten; Sun, Fengwu; Magdis, Georgios; Valentino, Francesco; Ao, Yiping; Toft, Sune; Dessauges-Zavadsky, Miroslava; Shimasaku, Kazuhiro; Caputi, Karina; Kusakabe, Haruka; Morokuma-Matsui, Kana; Shotaro, Kikuchihara; Egami, Eiichi; Lee, Minju M.; Rawle, Timothy; Espada, Daniel "ALMA Lensing Cluster Survey: Bright [C II] 158  $\mu\text{m}$  Lines from a Multiply Imaged Sub-L Galaxy at  $z = 6.0719$ " *The Astrophysical Journal*, 911 :99, 2021.
- Fuzia, Brittany J.; Kawinwanichakij, Lalitwadee; Mehrtens, Nicola; Aiola, Simone; Battaglia, Nicholas; Ciardullo, Robin; Devlin, Mark; Finkelstein, Steven L.; Gralla, Megan; Hilton, Matt; Huppenberger, Kevin M.; Hughes, John P.; Joglee, Sharda; Maldonado, Felipe A.; Page, Lyman A.; Papovich, Casey; Partridge, Bruce; Rykoff, Eli; Sehgal, Neelima; Sifón, Cristóbal; Staggs, Suzanne T.; Wollack, Edward "The Atacama Cosmology Telescope: SZ-based masses and dust emission from IR-selected cluster candidates in the SHELAs survey" *Monthly Notices of the Royal Astronomical Society*, 502 :4026, 2021.
- Fyhrie, Adalyn; Glenn, Jason; Rangwala, Naseem; Wheeler, Jordan; Beck, Sara; Bally, John "Molecular Gas in the Nuclear Region of NGC 6240" *The Astrophysical Journal*, 922 :208, 2021.
- Gabányi, Krisztina É.; Frey, Sándor; Perger, Krisztina "Radio emission from dust-obscured galaxies" *Monthly Notices of the Royal Astronomical Society*, 506 :3641, 2021.
- Gajjar, Vishal; Perez, Karen I.; Siemion, Andrew P. V.; Foster, Griffin; Brzycki,

## APPENDIX A: PUBLICATIONS

- Bryan; Chatterjee, Shami; Chen, Yuhong; Cordes, James M.; Croft, Steve; Czech, Daniel; Deboer, David; Demarines, Julia; Drew, Jamie; Gowanlock, Michael; Isaacson, Howard; Lacki, Brian C.; Lebofsky, Matt; Macmahon, David H. E.; Morrison, Ian S.; Ng, Cherry; De Pater, Imke; Price, Danny C.; Sheikh, Sofia Z.; Suresh, Akshay; Webb, Claire; Pete Worden, S. "The Breakthrough Listen Search For Intelligent Life Near the Galactic Center. I." *The Astronomical Journal*, 162 :33, 2021.
- Gallego-Calvente, A. T.; Schödel, R.; Alberdi, A.; Herrero-Illana, R.; Najarro, F.; Yusef-Zadeh, F.; Dong, H.; Sanchez-Bermudez, J.; Shahzamanian, B.; Nogueras-Lara, F.; Gallego-Cano, E. "Radio observations of massive stars in the Galactic centre: The Arches Cluster" *Astronomy and Astrophysics*, 647 :A110, 2021.
- Gao, Yulong; Egusa, Fumi; Liu, Guilin; Kohno, Kotaro; Bao, Min; Morokuma-Matsui, Kana; Kong, Xu; Chen, Xiaoyang "The Nuclear Region of NGC 1365: Star Formation, Negative Feedback, and Outflow Structure" *The Astrophysical Journal*, 913 :139, 2021.
- García-Burillo, S.; Alonso-Herrero, A.; Ramos Almeida, C.; González-Martín, O.; Combes, F.; Usero, A.; Hönl, S.; Querejeta, M.; Hicks, E. K. S.; Hunt, L. K.; Rosario, D.; Davies, R.; Boorman, P. G.; Bunker, A. J.; Burtscher, L.; Colina, L.; Díaz-Santos, T.; Gandhi, P.; García-Bernete, I.; García-Lorenzo, B.; Ichikawa, K.; Imanishi, M.; Izumi, T.; Labiano, A.; Levenson, N. A.; López-Rodríguez, E.; Packham, C.; Pereira-Santaella, M.; Ricci, C.; Rigopoulou, D.; Rouan, D.; Shimizu, T.; Stalevski, M.; Wada, K.; Williamson, D. "The Galaxy Activity, Torus, and Outflow Survey (GATOS). I. ALMA images of dusty molecular tori in Seyfert galaxies" *Astronomy and Astrophysics*, 652 :A98, 2021.
- Garg, H.; Pinte, C.; Christiaens, V.; Price, D. J.; Lazendic, J. S.; Boehler, Y.; Casassus, S.; Marino, S.; Perez, S.; Zuleta, A. "Non-Keplerian spirals, a gas-pressure dust trap, and an eccentric gas cavity in the circumbinary disc around HD 142527" *Monthly Notices of the Royal Astronomical Society*, 504 :782, 2021.
- Garsden, H.; Greenhill, L.; Bernardi, G.; Fialkov, A.; Price, D. C.; Mitchell, D.; Dowell, J.; Spinelli, M.; Schinzel, F. K. "A 21-cm power spectrum at 48 MHz, using the owens valley long wavelength array" *Monthly Notices of the Royal Astronomical Society*, 506 :5802, 2021.
- Garufi, A.; Podio, L.; Codella, C.; Fedele, D.; Bianchi, E.; Favre, C.; Bacciotti, F.; Ceccarelli, C.; Mercimek, S.; Rygl, K.; Teague, R.; Testi, L. "ALMA chemical survey of disk-outflow sources in Taurus (ALMA-DOT). V. Sample, overview, and demography of disk molecular emission" *Astronomy and Astrophysics*, 645 :A145, 2021.
- Gary, Dale E.; Bastian, Timothy S. "Solar Radio Burst Effects on Radio- and Radar-Based Systems" *Washington DC American Geophysical Union Geophysical Monograph Series*, 5 :141, 2021.
- Gault, Lexi; Leisman, Lukas; Adams, Elizabeth A. K.; Mancera Piña, Pavel E.; Reiter, Kameron; Smith, Nicholas; Battipaglia, Michael; Cannon, John M.; Fraternali, Filippo; Haynes, Martha P.; McCallan, Elizabeth; Pagel, Hannah J.; Rhode, Katherine L.; Salzer, John J.; Singer, Quinton "VLA Imaging of H I-bearing Ultra-diffuse Galaxies from the ALFALFA Survey" *The Astrophysical Journal*, 909 :19, 2021.
- Gehlot, Bharat K.; Jacobs, Daniel C.; Bowman, Judd D.; Mahesh, Nivedita; Murray, Steven G.; Kolopanis, Matthew; Beardsley, Adam P.; Abdurashidova, Zara; Aguirre, James E.; Alexander, Paul; Ali, Zaki S.; Balfour, Yanga; Bernardi, Gianni; Billings, Tashalee S.; Bradley, Richard F.; Bull, Phil; Burba, Jacob; Carey, Steve; Carilli, Chris L.; Cheng, Carina; Deboer, David R.; Dexter, Matt; De Lera Acedo, Eloy; Dillon, Joshua S.; Ely, John; Ewall-Wice, Aaron; Fagnoni, Nicolas; Fritz, Randall; Furlanetto, Steven R.; Gale-Sides, Kingsley; Glendenning, Brian; Gorthi, Deepthi; Greig, Bradley; Grobbelaar, Jasper; Halday, Ziyaad; Hazelton, Bryna J.; Hewitt, Jacqueline N.; Hickish, Jack; Julius, Austin; Kern, Nicholas S.; Kerrigan, Joshua; Kittiwisit, Piyanat; Kohn, Saul A.; Lanman, Adam; La Plante, Paul; Lekalake, Telalo; Lewis, David; Liu, Adrian; Ma, Yin-Zhe; Macmahon, David; Malan, Lourencia; Malgas, Cresshim; Maree, Mathty; Martinot, Zachary E.; Matssetela, Eunice; Mesinger, Andrei; Molewa, Mathakane; Monsalve, Raul A.; Morales, Miguel F.; Mosiane, Tshogofalang; Neben, Abraham R.; Nikolic, Bojan; Parsons, Aaron R.; Pascua, Robert; Patra, Nipanjana; Pieterse, Samantha; Pober, Jonathan C.; Razavi-Ghods, Nima; Ringuette, Jon; Robnett, James; Rosie, Kathryn; Santos, Mario G.; Sims, Peter; Smith, Craig; Syce, Angelo; Tegmark, Max; Thyagarajan, Nithyanandan; Williams, Peter K. G.; Zheng, Haoxuan "Effects of model incompleteness on the drift-scan calibration of radio telescopes" *Monthly Notices of the Royal Astronomical Society*, 506 :4578, 2021.
- Gendron-Marsolais, M.-L.; Hull, C. L. H.; Perley, R.; Rudnick, L.; Kraft, R.; Hlavacek-Larrondo, J.; Fabian, A. C.; Roediger, E.; Van Weeren, R. J.; Richard-Laferrrière, A.; Golden-Marx, E.; Arakawa, N.; McBride, J. D. "VLA Resolves Unexpected Radio Structures in the Perseus Cluster of Galaxies" *The Astrophysical Journal*, 911 :56, 2021.
- Gerin, M.; Liszt, H. "CO+ as a probe of the origin of CO in diffuse interstellar clouds" *Astronomy and Astrophysics*, 648 :A38, 2021.
- Gill, Ajay; Boyce, Michelle M.; O'Dea, Christopher P.; Baum, Stefi A.; Kharb, Preeti; Campbell, Neil; Tremblay, Grant R.; Kundu, Suman "Extended X-Ray Emission Associated with the Radio Lobes and the Environments of 60 Radio Galaxies" *The Astrophysical Journal*, 912 :88, 2021.
- Kim, Hansung B.; Borthakur, Sanchayeeta; Momjian, Emmanuel; Padave, Mansi; Jansen, Rolf A.; Nelson, Dylan; Heckman, Timothy M.; Kennicutt, Robert C., Jr.; Fox, Andrew J.; Pineda, Jorge L.; Thilker, David; Kauffmann, Guinevere; Tumlinson, Jason "DIISC-I: The Discovery of Kinematically Anomalous H I Clouds in M 100" *The Astrophysical Journal*, 922 :69, 2021.
- Ginski, Christian; Facchini, Stefano; Huang, Jane; Benisty, Myriam; Vaendel, Dennis; Stapper, Lucas; Dominik, Carsten; Bae, Jaehan; Ménard, François; Muro-Arena, Gabriela; Hogerheijde, Michiel R.; McClure, Melissa; Van Holstein, Rob G.; Birnstiel, Tilman; Boehler, Yann; Bohn, Alexander; Flock, Mario; Mamajek, Eric E.; Manara, Carlo F.; Pinilla, Paola; Pinte, Christophe; Ribas, Álvaro "Disk Evolution Study Through Imaging of Nearby Young Stars (DESTINYs): Late Infall Causing Disk Misalignment and Dynamic Structures in SU Aur" *The Astrophysical Journal*, 908 :L25, 2021.
- Girard, M.; Fisher, D. B.; Bolatto, A. D.; Abraham, R.; Bassett, R.; Glazebrook, K.; Herrera-Camus, R.; Jiménez, E.; Lenkić, L.; Obreschkow, D. "Systematic Difference between Ionized and Molecular Gas Velocity Dispersions in z = 1-2 Disks and Local Analogs" *The Astrophysical Journal*, 909 :12, 2021.
- Goddi, Ciriaco; Martí-Vidal, Iván; Messias, Hugo; Bower, Geoffrey C.; Broderick, Avery E.; Dexter, Jason; Marrone, Daniel P.; Moscibrodzka, Monika; Nagai, Hiroshi; Algaba, Juan Carlos; Asada, Keiichi; Crew, Geoffrey B.; Gómez, José L.; Impellizzeri, C. M. Violette; Janssen, Michael; Kadler, Matthias; Krichbaum, Thomas P.; Lico, Rocco; Matthews, Lynn D.; Nathanail, Antonios; Ricarte, Angelo; Ros, Eduardo; Younsi, Ziri; Akiyama, Kazunori; Alberdi, Antxon; Alef, Walter; Anantua, Richard; Azulay, Rebecca; Baczko, Anne-Kathrin; Ball, David; Baloković, Mislav; Barrett, John; Benson, Bradford A.; Bintley, Dan; Blackburn, Lindy; Blundell, Raymond; Boland, Wilfred; Bouman, Katherine L.; Boyce, Hope; Bremer, Michael; Brinkerink, Christiaan D.; Brissenden, Roger; Britzen, Silke; Brogiere, Dominique; Bronzwaer, Thomas; Byun, Do-Young; Carlstrom, John E.; Chael, Andrew; Chan, Chi-Kwan; Chatterjee, Shami; Chatterjee, Koushik; Chen, Ming-Tang; Chen, Yongjun; Chesler, Paul M.; Cho, Ilje; Christian, Pierre; Conway, John E.; Cordes, James M.; Crawford, Thomas M.; Cruz-Osorio, Alejandro; Cui, Yuzhu; Davelaar, Jordy; De Laurentis, Mariafelicia; Deane, Roger; Dempsey, Jessica; Desvignes, Gregory; Doleman, Sheperd S.; Eatough, Ralph P.; Falcke, Heino; Farah, Joseph; Fish, Vincent L.; Fomalont, Ed; Ford, H. Alyson; Fraga-Encinas, Raquel; Freeman, William T.; Friberg, Per; Fromm, Christian M.; Fuentes, Antonio; Galison, Peter; Gammie, Charles F.; García, Roberto; Gentaz, Olivier; Georgiev, Boris; Gold, Roman; Gómez-Ruiz, Arturo I.; Gu, Minfeng; Gurwell, Mark; Hada, Kazuhiro; Haggard, Daryl; Hecht, Michael H.; Hesper, Ronald; Ho, Luis C.; Ho, Paul; Honma, Mareki; Huang, Chih-Wei L.

- Huang, Lei; Hughes, David H.; Inoue, Makoto; Issaoun, Sara; James, David J.; Jannuzi, Buell T.; Jeter, Britton; Jiang, Wu; Jimenez-Rosales, Alejandra; Johnson, Michael D.; Jorstad, Svetlana; Jung, Taehyun; Karami, Mansour; Karuppusamy, Ramesh; Kawashima, Tomohisa; Keating, Garrett K.; Kettenis, Mark; Kim, Dong-Jin; Kim, Jae-Young; Kim, Jongsoo; Kim, Junhan; Kino, Motoki; Koay, Jun Yi; Kofuji, Yutaro; Koch, Patrick M.; Koyama, Shoko; Kramer, Michael; Kramer, Carsten; Kuo, Cheng-Yu; Lauer, Tod R.; Lee, Sang-Sung; Levis, Aviad; Li, Yan-Rong; Li, Zhiyuan; Lindqvist, Michael; Lindahl, Greg; Liu, Jun; Liu, Kuo; Liuzzo, Elisabetta; Lo, Wen-Ping; Lobanov, Andrei P.; Loinard, Laurent; Lonsdale, Colin; Lu, Ru-Sen; Macdonald, Nicholas R.; Mao, Jirong; Marchili, Nicola; Markoff, Sera; Marscher, Alan P.; Matsushita, Satoki; Medeiros, Lia; Menten, Karl M.; Mizuno, Izumi; Mizuno, Yosuke; Moran, James M.; Moriyama, Kotaro; Müller, Cornelia; Musoke, Gibwa; Mejías, Alejandro Mus; Nagar, Neil M.; Nakamura, Masanori; Narayan, Ramesh; Narayanan, Gopal; Natarajan, Iniyani; Neilsen, Joey; Neri, Roberto; Ni, Chunhong; Noutsos, Aristeidis; Nowak, Michael A.; Okino, Hiroki; Olivares, Héctor; Ortiz-León, Gisela N.; Oyama, Tomoaki; Özel, Feryal; Palumbo, Daniel C. M.; Park, Jongho; Patel, Nimesh; Pen, Ue-Li; Pesce, Dominic W.; Piétu, Vincent; Plambeck, Richard; Popstefanija, Aleksandar; Porth, Oliver; Pötl, Felix M.; Prather, Ben; Preciado-López, Jorge A.; Psaltis, Dimitrios; Pu, Hung-Yi; Ramakrishnan, Venkatesh; Rao, Ramprasad; Rawlings, Mark G.; Raymond, Alexander W.; Rezzolla, Luciano; Ripperda, Bart; Roelofs, Freek; Rogers, Alan; Rose, Mel; Roshanineshat, Arash; Rottmann, Helge; Roy, Alan L.; Ruszczyk, Chet; Rygl, Kazi L. J.; Sánchez, Salvador; Sánchez-Argüelles, David; Sasada, Mahito; Savolainen, Tuomas; Schloerb, F. Peter; Schuster, Karl-Friedrich; Shao, Lijing; Shen, Zhiqiang; Small, Des; Sohn, Bong Won; Soohoo, Jason; Sun, He; Tazaki, Fumie; Tetarenko, Alexandra J.; Tiede, Paul; Tilanus, Remo P. J.; Titus, Michael; Toma, Kenji; Torne, Pablo; Trent, Tyler; Traianou, Efthalia; Trippé, Sascha; Van Bemmell, Ilse; Van Langevelde, Huib Jan; Van Rossum, Daniel R.; Wagner, Jan; Ward-Thompson, Derek; Wardle, John; Weintraub, Jonathan; Wex, Norbert; Wharton, Robert; Wielgus, Maciek; Wong, George N.; Wu, Qingwen; Yoon, Doosoo; Young, André; Young, Ken; Yuan, Feng; Yuan, Ye-Fei; Zensus, J. Anton; Zhao, Guang-Yao; Zhao, Shan-Shan; Bruni, Gabriele; Gopakumar, A.; Hernández-Gómez, Antonio; Herrero-Illana, Ruben; Ingram, Adam; Komossa, S.; Kovalev, Y. Y.; Muders, Dirk; Perucho, Manel; Rösch, Florian; Valtonen, Mauri "Polarimetric Properties of Event Horizon Telescope Targets from ALMA" *The Astrophysical Journal*, 910 :L14, 2021.
- Golden-Marx, Emmet; Blanton, E. L.; Paterno-Mahler, R.; Brodwin, M.; Ashby, M. L. N.; Moravec, E.; Shen, L.; Lemaux, B. C.; Lubin, L. M.; Gal, R. R.; Tomczak, A. R. "The High-redshift Clusters Occupied by Bent Radio AGN (COBRA) Survey: Radio Source Properties" *The Astrophysical Journal*, 907 :65, 2021.
- Goncharov, Boris; Reardon, D. J.; Shannon, R. M.; Zhu, Xing-Jiang; Thrane, Eric; Bailes, M.; Bhat, N. D. R.; Dai, S.; Hobbs, G.; Kerr, M.; Manchester, R. N.; Oslowski, S.; Parthasarathy, A.; Russell, C. J.; Spiewak, R.; Thyagarajan, N.; Wang, J. B. "Identifying and mitigating noise sources in precision pulsar timing data sets" *Monthly Notices of the Royal Astronomical Society*, 502 :478, 2021.
- Goncharov, Boris; Shannon, R. M.; Reardon, D. J.; Hobbs, G.; Zic, A.; Bailes, M.; Curylo, M.; Dai, S.; Kerr, M.; Lower, M. E.; Manchester, R. N.; Mandow, R.; Middleton, H.; Miles, M. T.; Parthasarathy, A.; Thrane, E.; Thyagarajan, N.; Xue, X.; Zhu, X.-J.; Cameron, A. D.; Feng, Y.; Luo, R.; Russell, C. J.; Sarkissian, J.; Spiewak, R.; Wang, S.; Wang, J. B.; Zhang, L.; Zhang, S. "On the Evidence for a Common-spectrum Process in the Search for the Nanohertz Gravitational-wave Background with the Parkes Pulsar Timing Array" *The Astrophysical Journal*, 917 :L19, 2021.
- González-Alfonso, Eduardo; Pereira-Santaella, Miguel; Fischer, Jacqueline; García-Burillo, Santiago; Yang, Chentao; Alonso-Herrero, Almudena; Colina, Luis; Ashby, Matthew L. N.; Smith, Howard A.; Rico-Villas, Fernando; Martín-Pintado, Jesús; Cazzoli, Sara; Stewart, Kenneth P. "A proto-pseudobulge in ESO 320-G030 fed by a massive molecular inflow driven by a nuclear bar" *Astronomy and Astrophysics*, 645 :A49, 2021.
- Good, D. C.; Andersen, B. C.; Chawla, P.; Crowter, K.; Dong, F. Q.; Fonseca, E.; Meyers, B. W.; Ng, C.; Pleunis, Z.; Ransom, S. M.; Stairs, I. H.; Tan, C. M.; Bhardwaj, M.; Boyle, P. J.; Dobbs, M.; Gaensler, B. M.; Kaspi, V. M.; Masui, K. W.; Naidu, A.; Rafiei-Ravandi, M.; Scholz, P.; Smith, K. M.; Tendulkar, S. P. "First Discovery of New Pulsars and RRATs with CHIME/FRB" *The Astrophysical Journal*, 922 :43, 2021.
- Gorai, Prasanta; Das, Ankan; Shimonishi, Takashi; Sahu, Dipen; Mondal, Suman Kumar; Bhat, Bratati; Chakrabarti, Sandip K. "Identification of Methyl Isocyanate and Other Complex Organic Molecules in a Hot Molecular Core, G31.41+0.31" *The Astrophysical Journal*, 907 :108, 2021.
- Gordon, Yjan A.; Boyce, Michelle M.; O'Dea, Christopher P.; Rudnick, Lawrence; Andernach, Heinz; Vantygghem, Adrian N.; Baum, Stefi A.; Bui, Jean-Paul; Dionysiou, Mathew; Safi-Harb, Samar; Sander, Isabel "A Quick Look at the 3 GHz Radio Sky. I. Source Statistics from the Very Large Array Sky Survey" *The Astrophysical Journal Supplement Series*, 255 :30, 2021.
- Gorgone, Nicholas M.; Woudt, Patrick A.; Buckley, David; Mukai, Koji; Kouveliotou, Chryssa; Huppenkothen, Daniela; Göğüş, Ersin; Bellm, Eric; Linford, Justin D.; Van Der Horst, Alexander J.; Baring, Matthew G.; Hartmann, Dieter; Barrett, Paul; Cenko, Bradley; Graham, Melissa; Granot, Johnathan; Harrison, Fiona; Kennea, Jamie; O'Connor, Brendan M.; Potter, Stephen; Stern, Daniel; Slane, Patrick; Wijers, Ralph "Swift/XRT Deep Galactic Plane Survey Discovery of a New Intermediate Polar Cataclysmic Variable, Swift J183920.1-045350" *The Astrophysical Journal*, 923 :243, 2021.
- Gorski, M. D.; Aalto, S.; Mangum, J.; Momjian, E.; Black, J. H.; Falstad, N.; Gullberg, B.; König, S.; Onishi, K.; Sato, M.; Stanley, F. "Discovery of methanimine (CH<sub>2</sub>NH) megamasers toward compact obscured galaxy nuclei" *Astronomy and Astrophysics*, 654 :A110, 2021.
- Goswami, S.; Privon, G. C.; Santander, M.; Icecube Collaboration "Search for high-energy neutrino emission from hard X-ray AGN with IceCube" *Journal of Instrumentation*, 16 :C09013, 2021.
- Grandorf, C.; Mccarty, J.; Rajkumar, P.; Harbin, H.; Lee, K. H.; Corsi, A.; Bartos, I.; Márka, Z.; Balasubramanian, A.; Márka, S. "Search for Radio Remnants of Nearby Off-axis Gamma-Ray Bursts in a Sample of Swift/BAT Events" *The Astrophysical Journal*, 908 :63, 2021.
- Grant, Sierra L.; Espaillat, Catherine C.; Wendeborn, John; Tobin, John J.; Macías, Enrique; Rillinger, Anneliese; Ribas, Álvaro; Thomas Megeath, S.; Fischer, William J.; Calvet, Nuria; Hee Kim, Kyoung "An ALMA Survey of Protoplanetary Disks in Lynds 1641" *The Astrophysical Journal*, 913 :123, 2021.
- Gratier, Pierre; Pety, Jérôme; Bron, Emeric; Roueff, Antoine; Orkisz, Jan H.; Gerin, Maryvonne; De Souza Magalhaes, Victor; Gaudel, Mathilde; Vono, Maxime; Bardeau, Sébastien; Chanussot, Jocelyn; Chainais, Pierre; Goicoechea, Javier R.; Guzmán, Viviana V.; Hughes, Annie; Kainulainen, Jouni; Languignon, David; Le Bourlot, Jacques; Le Petit, Franck; Levrier, François; Liszt, Harvey; Peretto, Nicolas; Roueff, Evlyne; Sievers, Albrecht "Quantitative inference of the H<sub>2</sub> column densities from 3 mm molecular emission: case study towards Orion B" *Astronomy and Astrophysics*, 645 :A27, 2021.
- Greaves, Jane S.; Richards, Anita M. S.; Bains, William; Rimmer, Paul B.; Sagawa, Hideo; Clements, David L.; Seager, Sara; Petkowski, Janusz J.; Sousa-Silva, Clara; Ranjan, Sukrit; Drabek-Mauder, Emily; Fraser, Helen J.; Cartwright, Annabel; Mueller-Wodarg, Ingo; Zhan, Zhuchang; Friberg, Per; Coulson, Iain; Lee, E'Lisa; Hoge, Jim "Phosphine gas in the cloud decks of Venus" *Nature Astronomy*, 5 :p. 655-664, 2021.
- Green, D. A.; Madhusudhan, N. "Search for radio emission from the exoplanets Qatar-1b and WASP-80b near 150 MHz using the giant metrewave radio telescope" *Monthly Notices of the Royal Astronomical Society*, 500 :211, 2021.

## APPENDIX A: PUBLICATIONS

- Grishin, Kirill A.; Chilingarian, Igor V.; Afanasiev, Anton V.; Fabricant, Daniel; Katkov, Ivan Yu.; Moran, Sean; Yagi, Masafumi "Transforming gas-rich low-mass disk galaxies into ultra-diffuse galaxies by ram pressure" *Nature Astronomy*, 5 :1308, 2021.
- Gulick, Hannah C.; Sadavoy, Sarah; Matrà, Luca; Sheehan, Patrick; Van Der Marel, Nienke "Detection of Substructures in Young Transition Disk WL 17" *The Astrophysical Journal*, 922 :150, 2021.
- Guo, Y. J.; Freire, P. C. C.; Guillemot, L.; Kramer, M.; Zhu, W. W.; Wex, N.; Mckee, J. W.; Deller, A.; Ding, H.; Kaplan, D. L.; Stappers, B.; Cognard, I.; Miao, X.; Haase, L.; Keith, M.; Ransom, S. M.; Theureau, G. "PSR J2222-0137. I. Improved physical parameters for the system" *Astronomy and Astrophysics*, 654 :A16, 2021.
- Gupta, K. K.; Ricci, C.; Tortosa, A.; Ueda, Y.; Kawamuro, T.; Koss, M.; Trakhtenbrot, B.; Oh, K.; Bauer, F. E.; Ricci, F.; Privon, G. C.; Zappacosta, L.; Stern, D.; Kakkad, D.; Piconcelli, E.; Veilleux, S.; Mushotzky, R.; Caglar, T.; Ichikawa, K.; Elagali, A.; Powell, M. C.; Urry, C. M.; Harrison, F. "BAT AGN Spectroscopic Survey XXVII: Scattered X-Ray Radiation in Obscured Active Galactic Nuclei" *Monthly Notices of the Royal Astronomical Society*, 504 :428, 2021.
- Gupta, N.; Jagannathan, P.; Srianand, R.; Bhatnagar, S.; Noterdaeme, P.; Combes, F.; Petitjean, P.; Jose, J.; Pandey, S.; Kaski, C.; Baker, A. J.; Balashev, S. A.; Boettcher, E.; Chen, H.-W.; Cress, C.; Dutta, R.; Goedhart, S.; Heald, G.; Józsa, G. I. G.; Kamau, E.; Kamphuis, P.; Kerp, J.; Klöckner, H.-R.; Knowles, K.; Krishnan, V.; Krogager, J. - K.; Kulkarni, V. P.; Momjian, E.; Moodley, K.; Passmoor, S.; Schröder, A.; Sekhar, S.; Sikhosana, S.; Wagenveld, J.; Wong, O. I. "Blind H I and OH Absorption Line Search: First Results with MALS and uGMRT Processed Using ARTIP" *The Astrophysical Journal*, 907 :11, 2021.
- Gupta, N.; Srianand, R.; Shukla, G.; Krogager, J. - K.; Noterdaeme, P.; Combes, F.; Dutta, R.; Fynbo, J. P. U.; Hiltun, M.; Momjian, E.; Moodley, K.; Petitjean, P. "Evolution of Cold Gas at  $2 < z < 5$ : A Blind Search for H I and OH Absorption Lines toward Mid-infrared Color-selected Radio-loud AGN" *The Astrophysical Journal Supplement Series*, 255 :28, 2021.
- Gürkan, Gülay; Croston, Judith; Hardcastle, Martin J.; Mahatma, Vijay; Mingo, Beatriz; Williams, Wendy L. "Finding Rare Quasars: VLA Snapshot Continuum Survey of FRI Quasar Candidates Selected from the LOFAR Two-Metre Sky Survey (LoTSS)" *Galaxies*, 10 :2, 2021.
- Guzmán, Viviana V.; Bergner, Jennifer B.; Law, Charles J.; Öberg, Karin I.; Walsh, Catherine; Cataldi, Gianni; Aikawa, Yuri; Bergin, Edwin A.; Czekala, Ian; Huang, Jane; Andrews, Sean M.; Loomis, Ryan A.; Zhang, Ke; Le Gal, Romane; Alarcón, Felipe; Ilee, John D.; Teague, Richard; Cleeves, L. Ilse; Wilner, David J.; Long, Feng; Schwarz, Kamber R.; Bosman, Arthur D.; Pérez, Laura M.; Ménard, François; Liu, Yao "Molecules with ALMA at Planet-forming Scales (MAPS). VI. Distribution of the Small Organics HCN, C<sub>2</sub>H, and H<sub>2</sub>CO" *The Astrophysical Journal Supplement Series*, 257 :6, 2021.
- Guzmán-Díaz, J.; Mendigutía, I.; Montesinos, B.; Oudmaijer, R. D.; Vioque, M.; Rodrigo, C.; Solano, E.; Meeus, G.; Marcos-Arenal, P. "Homogeneous study of Herbig Ae/Be stars from spectral energy distributions and Gaia EDR3" *Astronomy and Astrophysics*, 650 :A182, 2021.
- H. E. S. S. Collaboration; Abdalla, H.; Adam, R.; Aharonian, F.; Ait Benkhali, F.; Angüner, E. O.; Arcaro, C.; Armand, C.; Armstrong, T.; Ashkar, H.; Backes, M.; Baghmany, V.; Barbosa Martins, V.; Barnacka, A.; Barnard, M.; Becherini, Y.; Berge, D.; Bernlöhr, K.; Bi, B.; Böttcher, M.; Boisson, C.; Bolmont, J.; Bonnefoy, S.; De Bony De Lavergne, M.; Bregeson, J.; Breuhaus, M.; Brun, F.; Brun, P.; Bryan, M.; Büchele, M.; Bulik, T.; Bylund, T.; Caroff, S.; Carosi, A.; Casanova, S.; Chand, T.; Chandra, S.; Chen, A.; Cotter, G.; Curyło, M.; Damascene Mbarubucyeye, J.; Davids, I. D.; Davies, J.; Deil, C.; Devin, J.; Dewilt, P.; Dirson, L.; Djannati-Ataï, A.; Dmytriiev, A.; Donath, A.; Doroshenko, V.; Dyks, J.; Egberts, K.; Eichhorn, F.; Einecke, S.; Emery, G.; Ernenwein, J.-P.; Feijen, K.; Fegan, S.; Fiason, A.; Fichtel De Clairfontaine, G.; Filipovic, M.; Fontaine, G.; Funk, S.; Fülling, M.; Gabici, S.; Gallant, Y. A.; Giavitto, G.; Giunti, L.; Glawion, D.; Glicenstein, J. F.; Gottschall, D.; Grondin, M.-H.; Hahn, J.; Haupt, M.; Hermann, G.; Hinton, J. A.; Hofmann, W.; Hoischen, C.; Holch, T. L.; Holler, M.; Hörbe, M.; Horns, D.; Huber, D.; Jamroz, M.; Jankowsky, D.; Jankowsky, F.; Jardin-Blicq, A.; Joshi, V.; Jung-Richardt, I.; Kastendieck, M. A.; Katarzyński, K.; Katz, U.; Khangulyan, D.; Khélifi, B.; Klepser, S.; Kluźniak, W.; Komin, Nu.; Konno, R.; Kosack, K.; Kostunin, D.; Kreter, M.; Lamanna, G.; Lemièrre, A.; Lemoine-Goumard, M.; Lenain, J.-P.; Levy, C.; Lohse, T.; Lypova, I.; Mackey, J.; Majumdar, J.; Malyshev, D.; Malyshev, D.; Marandon, V.; Marchegiani, P.; Marcowith, A.; Mares, A.; Martí-Devesa, G.; Marx, R.; Maurin, G.; Meintjes, P. J.; Meyer, M.; Mitchell, A. M. W.; Moderski, R.; Mohamed, M.; Mohrmann, L.; Montanari, A.; Moore, C.; Morris, P.; Moulin, E.; Müller, J.; Murach, T.; Nakashima, K.; Nayerhoda, A.; De Naurois, M.; Ndiayala, H.; Niedervanger, F.; Niemiec, J.; Oakes, L.; O'Brien, P.; Odaka, H.; Ohm, S.; Olivera-Nieto, L.; De Ona Wilhelmi, E.; Ostrowski, M.; Panter, M.; Panny, S.; Parsons, R. D.; Peron, G.; Peyaud, B.; Piel, Q.; Pita, S.; Poireau, V.; Priyana Noel, A.; Prokhorov, D. A.; Prokoph, H.; Pühlhofer, G.; Punch, M.; Quirrenbach, A.; Raab, S.; Rauth, R.; Reichherzer, P.; Reimer, A.; Reimer, O.; Remy, Q.; Renaud, M.; Rieger, F.; Rinchiuso, L.; Romoli, C.; Rowell, G.; Rudak, B.; Ruiz-Velasco, E.; Sahakian, V.; Sailer, S.; Sanchez, D. A.; Santangelo, A.; Sasaki, M.; Scalici, M.; Schüssler, F.; Schutte, H. M.; Schwanke, U.; Schwemmer, S.; Seglar-Arroyo, M.; Senniappan, M.; Seyffert, A. S.; Shafi, N.; Shiningayamwe, K.; Simoni, R.; Sinha, A.; Sol, H.; Specovius, A.; Spencer, S.; Spir-Jacob, M.; Stawarz, Ł.; Sun, L.; Steenkamp, R.; Stegmann, C.; Steinmassl, S.; Steppa, C.; Takahashi, T.; Tavernier, T.; Taylor, A. M.; Terrier, R.; Tiziani, D.; Tluczykont, M.; Tomankova, L.; Trichard, C.; Tsirou, M.; Tuffs, R.; Uchiyama, Y.; Van Der Walt, D. J.; Van Eldik, C.; Van Rensburg, C.; Van Soelen, B.; Vasileiadis, G.; Veh, J.; Venter, C.; Vincent, P.; Vink, J.; Völk, H. J.; Vuillaume, T.; Wadiasingh, Z.; Wagner, S. J.; Watson, J.; Werner, F.; White, R.; Wierzycholska, A.; Wong, Yu. W.; Yusufzai, A.; Zacharias, M.; Zanin, R.; Zargaryan, D.; Zdziarski, A. A.; Zech, A.; Zhu, S. J.; Zorn, J.; Zouari, S.; Żywucka, N.; Magic Collaboration; Acciari, V. A.; Ansoldi, S.; Antonelli, L. A.; Arbet Engels, A.; Asano, K.; Baack, D.; Babić, A.; Baquero, A.; Barres De Almeida, U.; Barrio, J. A.; Becerra González, J.; Bednarek, W.; Bellizzi, L.; Bernardini, E.; Berti, A.; Besenrieder, J.; Bhattacharyya, W.; Bigongiari, C.; Biland, A.; Blanch, O.; Bonnoli, G.; Bošnjak, Ž.; Busetto, G.; Carosi, R.; Ceribella, G.; Cerruti, M.; Chai, Y.; Chilingarian, A.; Cikota, S.; Colak, S. M.; Colin, U.; Colombo, E.; Contreras, J. L.; Cortina, J.; Covino, S.; D'Amico, G.; D'Elia, V.; Da Vela, P.; Dazzi, F.; De Angelis, A.; De Lotto, B.; Delfino, M.; Delgado, J.; Depaoli, D.; Di Piero, F.; Di Venere, L.; Do Souto Espiñeira, E.; Dominis Prester, D.; Donini, A.; Dorner, D.; Doro, M.; Elsaesser, D.; Fallah Ramazani, V.; Fattorini, A.; Ferrara, G.; Foffano, L.; Fonseca, M. V.; Font, L.; Fruck, C.; Fukami, S.; García López, R. J.; Garczarczyk, M.; Gasparyan, S.; Gaug, M.; Giglietto, N.; Giordano, F.; Gliwny, P.; Godinović, N.; Green, D.; Hadasch, D.; Hahn, A.; Heckmann, L.; Herrera, J.; Hoang, J.; Hrupec, D.; Hütten, M.; Inada, T.; Inoue, S.; Ishio, K.; Iwamura, Y.; Jouvin, L.; Kajiwara, Y.; Karjalainen, M.; Kerszberg, D.; Kobayashi, Y.; Kubo, H.; Kushida, J.; Lamastra, A.; Lelas, D.; Leone, F.; Lindfors, E.; Lombardi, S.; Longo, F.; López, M.; López-Coto, R.; López-Oramas, A.; Loporchio, S.; Machado De Oliveira Fraga, B.; Maggio, C.; Majumdar, P.; Makariev, M.; Malmalaci, M.; Maneva, G.; Manganaro, M.; Mannheim, K.; Maraschi, L.; Mariotti, M.; Martínez, M.; Mazin, D.; Mender, S.; Mićanović, S.; Miceli, D.; Miener, T.; Mineev, M.; Miranda, J. M.; Mirzoyan, R.; Molina, E.; Moralejo, A.; Morcuende, D.; Moreno, V.; Moretti, E.; Munar-Adrover, P.; Neustroev, V.; Nigro, C.; Nilsson, K.; Ninci, D.; Nishijima, K.; Noda, K.; Nozaki, S.; Ohtani, Y.; Oka, T.; Otero-Santos, J.; Palatiello, M.; Paneque, D.; Paoletti, R.; Paredes, J. M.; Pavletić, L.; Peñil, P.; Perennes, C.; Persic, M.; Prada Moroni, P. G.; Prandini, E.; Priyadarshi, C.; Puljak, I.; Rhode, W.; Ribó, M.; Rico, J.; Righi, C.; Rugliancich, A.; Saha, L.; Sahakyan, N.; Saito, T.; Sakurai, S.; Satalecka, K.; Schleicher, B.; Schmidt, K.; Schweizer, T.; Sitarek, J.; Šnidarić, I.; Sobczynska, D.; Spolon, A.; Stamerra, A.; Strom, D.; Strzys, M.; Suda, Y.; Suric, T.; Takahashi, M.; Tavecchio, F.; Temnikov, P.; Terzić,



- T.; Teshima, M.; Torres-Albà, N.; Tosti, L.; Truzzi, S.; Van Scherpenberg, J.; Vanzo, G.; Vazquez Acosta, M.; Ventura, S.; Verguillo, V.; Vigorito, C. F.; Vitale, V.; Vovk, I.; Will, M.; Zarić, D.; Jorstad, S. G.; Marscher, A. P.; Boccardi, B.; Casadio, C.; Hodgson, J.; Kim, J.-Y.; Krichbaum, T. P.; Lähteenmäki, A.; Tornikoski, M.; Traianou, E.; Weaver, Z. R. "H.E.S.S. and MAGIC observations of a sudden cessation of a very-high-energy  $\gamma$ -ray flare in PKS 1510-089 in May 2016" *Astronomy and Astrophysics*, 648 :A23, 2021.
- Habel, Nolan M.; Megeath, S. Thomas; Booker, Joseph Jon; Fischer, William J.; Kounkel, Marina; Poteet, Charles; Furlan, Elise; Stutz, Amelia; Manoj, P.; Tobin, John J.; Nagy, Zsófia; Pokhrel, Riway; Watson, Dan "An HST Survey of Protostellar Outflow Cavities: Does Feedback Clear Envelopes?" *The Astrophysical Journal*, 911 :153, 2021.
- Hagen-Thorn, V. A.; Morozova, D. A.; Savchenko, S. S.; Hagen-Thorn, E. I.; Milanova, Yu. V.; Shalyapina, L. V.; Vasil'Ev, A. A. "Variability of the Blazar 1156+295 in 2005-2020" *Astronomy Reports*, 65 :1233, 2021.
- Hagiwara, Yoshiaki; Horiuchi, Shinji; Imanishi, Masatoshi; Edwards, Philip G. "Second-epoch ALMA Observations of 321 GHz Water Maser Emission in NGC 4945 and the Circinus Galaxy" *The Astrophysical Journal*, 923 :251, 2021.
- Haikala, L. K.; Salinas, R.; Richtler, T.; Gómez, M.; Gahm, G. F.; Mattila, K. "ALMA detection of the dusty object silhouetted against the SO galaxy NGC 3269 in the Antlia cluster" *Astronomy and Astrophysics*, 645 :A36, 2021.
- Hajduk, Marcin; Haverkorn, Marijke; Shimwell, Timothy; Olech, Mateusz; Callingham, Joseph R.; Vedantham, Harish K.; White, Glenn J.; Iacobelli, Marco; Drabent, Alexander "Evidence for Cold Plasma in Planetary Nebulae From Radio Observations With the LOw Frequency ARray (LOFAR)" *The Astrophysical Journal*, 919 :121, 2021.
- Hamed, M.; Ciesla, L.; Béthermin, M.; Malek, K.; Daddi, E.; Sargent, M. T.; Gobat, R. "Multiwavelength dissection of a massive heavily dust-obscured galaxy and its blue companion at  $z \approx 2$ " *Astronomy and Astrophysics*, 646 :A127, 2021.
- Haniewicz, H. T.; Ferdman, R. D.; Freire, P. C. C.; Champion, D. J.; Bunting, K. A.; Lorimer, D. R.; McLaughlin, M. A. "Precise mass measurements for the double neutron star system J1829+2456" *Monthly Notices of the Royal Astronomical Society*, 500 :4620, 2021.
- Hara, Chihomi; Kawabe, Ryohei; Nakamura, Fumitaka; Hirano, Naomi; Takakuwa, Shigehisa; Shimajiri, Yoshito; Kamazaki, Takeshi; Di Francesco, James; Machida, Masahiro N.; Tamura, Motohide; Saigo, Kazuya; Matsumoto, Tomoaki; Tomida, Kengo "Misaligned Twin Molecular Outflows from the Class 0 Protostellar Binary System VLA 1623A Unveiled by ALMA" *The Astrophysical Journal*, 912 :34, 2021.
- Harada, Nanase; Martín, Sergio; Mangum, Jeffrey G.; Sakamoto, Kazushi; Muller, Sebastien; Tanaka, Kunihiro; Nakanishi, Kouichiro; Herrero-Illana, Rubén; Yoshimura, Yuki; Mühle, Stefanie; Aladro, Rebeca; Colzi, Laura; Rivilla, Víctor M.; Aalto, Susanne; Behrens, Erica; Henkel, Christian; Holdship, Jonathan; Humire, P. K.; Meier, David S.; Nishimura, Yuri; Van Der Werf, Paul P.; Viti, Serena "Starburst Energy Feedback Seen through HCO+/HOC+ Emission in NGC 253 from ALCHEM!" *The Astrophysical Journal*, 923 :24, 2021.
- Harrington, Kevin C.; Weiss, Axel; Yun, Min S.; Magnelli, Benjamin; Sharon, C. E.; Leung, T. K. D.; Vishwas, A.; Wang, Q. D.; Frayer, D. T.; Jiménez-Andrade, E. F.; Liu, D.; García, P.; Romano-Díaz, E.; Frye, B. L.; Jarugula, S.; Bădescu, T.; Berman, D.; Dannerbauer, H.; Díaz-Sánchez, A.; Grassitelli, L.; Kamiński, P.; Kim, W. J.; Kirkpatrick, A.; Lowenthal, J. D.; Messias, H.; Puschign, J.; Stacey, G. J.; Torne, P.; Bertoldi, F. "Turbulent Gas in Lensed Planck-selected Starbursts at  $z \approx 1-3.5$ " *The Astrophysical Journal*, 908 :95, 2021.
- Harris, Chelsea E.; Chomiuk, Laura; Nugent, Peter E. "Tumbling Dice: Radio Constraints on the Presence of Circumstellar Shells around Type Ia Supernovae with Impact Near Maximum Light" *The Astrophysical Journal*, 912 :23, 2021.
- Harrison, Rachel E.; Looney, Leslie W.; Stephens, Ian W.; Li, Zhi-Yun; Teague, Richard; Crutcher, Richard M.; Yang, Haifeng; Cox, Erin G.; Fernández-López, Manuel; Shinnaga, Hiroko "ALMA CN Zeeman Observations of AS 209: Limits on Magnetic Field Strength and Magnetically Driven Accretion Rate" *The Astrophysical Journal*, 908 :141, 2021.
- Harsono, D.; Van Der Wiel, M. H. D.; Bjerkeli, P.; Ramsey, J. P.; Calcutt, H.; Kristensen, L. E.; Jørgensen, J. K. "Resolved molecular line observations reveal an inherited molecular layer in the young disk around TMC1A" *Astronomy and Astrophysics*, 646 :A72, 2021.
- Hartley, P.; Jackson, N.; Badole, S.; Mckean, J. P.; Sluse, D.; Vives-Arias, H. "Using strong lensing to understand the microJy radio emission in two radio quiet quasars at redshift 1.7" *Monthly Notices of the Royal Astronomical Society*, 508 :4625, 2021.
- Hashimoto, Jun; Dong, Ruobing; Muto, Takayuki "An Asymmetric Dust Ring around a Very Low Mass Star ZZ Tau IRS" *The Astronomical Journal*, 161 :264, 2021.
- Hashimoto, Jun; Muto, Takayuki; Dong, Ruobing; Hasegawa, Yasuhiro; Marel, Nienke Van Der; Tamura, Motohide; Takami, Michihiro; Momose, Munetake "ALMA Observations of the Inner Cavity in the Protoplanetary Disk around Sz 84" *The Astrophysical Journal*, 908 :250, 2021.
- Hashimoto, Jun; Muto, Takayuki; Dong, Ruobing; Liu, Hanyu Baobab; Van Der Marel, Nienke; Francis, Logan; Hasegawa, Yasuhiro; Tsukagoshi, Takashi "ALMA Observations of the Asymmetric Dust Disk around DM Tau" *The Astrophysical Journal*, 911 :5, 2021.
- Hatsukade, B.; Tominaga, N.; Morokuma, T.; Morokuma-Matsui, K.; Tamura, Y.; Niinuma, K.; Hayashi, M.; Matsuda, Y.; Motogi, K. "Variability of Late-time Radio Emission in the Superluminous Supernova PTF10hgi" *The Astrophysical Journal*, 911 :L1, 2021.
- Hatsukade, Bunyo; Tominaga, Nozomu; Morokuma, Tomoki; Morokuma-Matsui, Kana; Matsuda, Yuichi; Tamura, Yoichi; Niinuma, Kotaro; Motogi, Kazuhiro "A VLA Survey of Late-time Radio Emission from Superluminous Supernovae and the Host Galaxies" *The Astrophysical Journal*, 922 :17, 2021.
- Hayashi, Takayuki J.; Hagiwara, Yoshiaki; Imanishi, Masatoshi "Radio properties of 10 nearby ultraluminous infrared galaxies with signatures of luminous buried active galactic nuclei" *Monthly Notices of the Royal Astronomical Society*, 504 :2675, 2021.
- Heintz, K. E.; Björnsson, G.; Neeleman, M.; Christensen, L.; Fynbo, J. P. U.; Jakobsson, P.; Krogager, J.-K.; Laskar, T.; Ledoux, C.; Magdis, G.; Møller, P.; Noterdaeme, P.; Schady, P.; De Ugarte Postigo, A.; Valentino, F.; Watson, D. "GRB host galaxies with strong H2 absorption: CO-dark molecular gas at the peak of cosmic star formation" *Monthly Notices of the Royal Astronomical Society*, 507 :1434, 2021.
- Herrera-Camus, R.; Förster Schreiber, N.; Genzel, R.; Tacconi, L.; Bolatto, A.; Davies, R. L.; Fisher, D.; Lutz, D.; Naab, T.; Shimizu, T.; Tadaki, K.; Übler, H. "Kiloparsec view of a typical star-forming galaxy when the Universe was 1 Gyr old. I. Properties of outflow, halo, and interstellar medium" *Astronomy and Astrophysics*, 649 :A31, 2021.
- Heywood, I.; Murphy, E. J.; Jiménez-Andrade, E. F.; Armus, L.; Cotton, W. D.; Decoursey, C.; Dickinson, M.; Lazio, T. J. W.; Momjian, E.; Penner, K.; Smal, I.; Smirnov, O. M. "The VLA Frontier Fields Survey: Deep, High-resolution Radio Imaging of the MACS Lensing Clusters at 3 and 6 GHz" *The Astrophysical Journal*, 910 :105, 2021.
- Hilmarsson, G. H.; Michilli, D.; Spitler, L. G.; Wharton, R. S.; Demorest, P.; Desvignes, G.; Gourdj, K.; Hackstein, S.; Hessels, J. W. T.; Nimmo, K.; Seymour, A. D.; Kramer, M.; McKinven, R. "Rotation Measure Evolution of the Repeating Fast Radio Burst Source FRB 121102" *The Astrophysical Journal*, 908 :L10, 2021.
- Hirota, Tomoya; Cesaroni, Riccardo; Moscadedelli, Luca; Sugiyama, Koichiro; Burns, Ross A.; Kim, Jung-ha; Sunada, Kazuyoshi; Yonekura, Yoshinori "Water maser variability in a high-mass YSO outburst. VERA and ALMA observations of S255 NIRS 3" *Astronomy and Astrophysics*, 647 :A23, 2021.
- Hoang, D. N.; Shimwell, T. W.; Osinga, E.; Bonafede, A.; Brüggem, M.; Botteon, A.; Brunetti, G.; Cassano, R.; Cuciti, V.; Drabent, A.; Jones, C.;

## APPENDIX A: PUBLICATIONS

- Röttgering, H. J. A.; Van Weeren, R. J. "LOFAR detection of a low-power radio halo in the galaxy cluster Abell 990" *Monthly Notices of the Royal Astronomical Society*, 501 :576, 2021.
- Hoang, D. N.; Zhang, X.; Stuardi, C.; Shimwell, T. W.; Bonafede, A.; Brüggem, M.; Brunetti, G.; Botteon, A.; Cassano, R.; De Gasperin, F.; Di Gennaro, G.; Hoeft, M.; Intema, H.; Rajpurohit, K.; Röttgering, H. J. A.; Simionescu, A.; Van Weeren, R. J. "A 3.5 Mpc long radio relic in the galaxy cluster CIG 0217+70" *Astronomy and Astrophysics*, 656 :A154, 2021.
- Hodges-Kluck, Edmund; Gallo, Elena; Ghisellini, Gabriele; Haardt, Francesco; Wu, Jianfeng; Ciardi, Benedetta "Proof of CMB-driven X-ray brightening of high-z radio galaxies" *Monthly Notices of the Royal Astronomical Society*, 505 :1543, 2021.
- Hodgson, Jeffrey A.; Rani, Bindu; Oh, Junghwan; Marscher, Alan; Jorstad, Svetlana; Mizuno, Yosuke; Park, Jongho; Lee, S. S.; Tripp, Sascha; Mertens, Florent "A Detailed Kinematic Study of 3C 84 and Its Connection to  $\gamma$ -Rays" *The Astrophysical Journal*, 914 :43, 2021.
- Hogarth, L. M.; Saintonge, A.; Cortese, L.; Davis, T. A.; Croom, S. M.; Bland-Hawthorn, J.; Brough, S.; Bryant, J. J.; Catinella, B.; Fletcher, T. J.; Groves, B.; Lawrence, J. S.; López-Sánchez, Á. R.; Owers, M. S.; Richards, S. N.; Roberts-Borsani, G. W.; Taylor, E. N.; Van De Sande, J.; Scott, N. "Centrally concentrated molecular gas driving galactic-scale ionized gas outflows in star-forming galaxies" *Monthly Notices of the Royal Astronomical Society*, 500 :3802, 2021.
- Hogg, J. Drew; Blecha, Laura; Reynolds, Christopher S.; Smith, Krista Lynne; Winter, Lisa M. "2MASX J00423991 + 3017515: an offset active galactic nucleus in an interacting system" *Monthly Notices of the Royal Astronomical Society*, 503 :1688, 2021.
- Holdship, J.; Viti, S.; Martín, S.; Harada, N.; Mangum, J.; Sakamoto, K.; Müller, S.; Tanaka, K.; Yoshimura, Y.; Nakanishi, K.; Herrero-Illana, R.; Mühle, S.; Aladro, R.; Colzi, L.; Emig, K. L.; García-Burillo, S.; Henkel, C.; Humire, P.; Meier, D. S.; Rivilla, V. M.; Van Der Werf, P. "The distribution and origin of C2H in NGC 253 from ALCHEMI" *Astronomy and Astrophysics*, 654 :A55, 2021.
- Homan, D. C.; Cohen, M. H.; Hovatta, T.; Kellermann, K. I.; Kovalev, Y. Y.; Lister, M. L.; Popkov, A. V.; Pushkarev, A. B.; Ros, E.; Savolainen, T. "MOJAVE. XIX. Brightness Temperatures and Intrinsic Properties of Blazar Jets" *The Astrophysical Journal*, 923 :67, 2021.
- Homan, Ward; Pimpanuwat, Bannawit; Herpin, Fabrice; Danilovich, Taissa; McDonald, Iain; Wallström, Sofia H. J.; Richards, Anita M. S.; Baudry, Alain; Sahai, Raghvendra; Millar, Tom J.; De Koter, Alex; Gottlieb, C. A.; Kervella, Pierre; Montargès, Miguel; Van De Sande, Marie; Decin, Leen; Zijlstra, Albert; Etoka, Sandra; Jeste, Manali; Müller, Holger S. P.; Maes, Silke; Malfait, Jolien; Menten, Karl; Plane, John; Lee, Kelvin; Waters, Rens; Wong, Ka Tat; Lagadec, Eric; Gobrecht, David; Yates, Jeremy; Price, Daniel; Cannon, Emily; Bolte, Jan; De Ceuster, Frederik; Nuth, Joe; Philip Sindel, Jan; Kee, Dylan; Gray, Malcolm D.; El Mellah, Ileyk "ATOMIUM: The astounding complexity of the near circumstellar environment of the M-type AGB star R Hydrae. I. Morpho-kinematical interpretation of CO and SiO emission" *Astronomy and Astrophysics*, 651 :A82, 2021.
- Horesh, A.; Cenko, S. B.; Arcavi, I. "Delayed radio flares from a tidal disruption event" *Nature Astronomy*, vol 5 :491, 2021.
- Horesh, Assaf; Sfaradi, Itai; Fender, Rob; Green, David A.; Williams, David R. A.; Bright, Joe S. "Are Delayed Radio Flares Common in Tidal Disruption Events? The Case of the TDE iPTF 16fni" *The Astrophysical Journal*, 920 :L5, 2021.
- Hotan, A. W.; Bunton, J. D.; Chippendale, A. P.; Whiting, M.; Tuthill, J.; Moss, V. A.; McConnell, D.; Amy, S. W.; Huynh, M. T.; Allison, J. R.; Anderson, C. S.; Bannister, K. W.; Bastholm, E.; Beresford, R.; Bock, D. C.-J.; Bolton, R.; Chapman, J. M.; Chow, K.; Collier, J. D.; Cooray, F. R.; Cornwell, T. J.; Diamond, P. J.; Edwards, P. G.; Feain, I. J.; Franzen, T. M. O.; George, D.; Gupta, N.; Hampson, G. A.; Harvey-Smith, L.; Hayman, D. B.; Heywood, I.; Jacka, C.; Jackson, C. A.; Jackson, S.; Jeganathan, K.; Johnston, S.; Kesteven, M.; Kleiner, D.; Koribalski, B. S.; Lee-Waddell, K.; Lenc, E.; Lensson, E. S.; Mackay, S.; Mahony, E. K.; McClure-Griffiths, N. M.; McConigley, R.; Mirtschin, P.; Ng, A. K.; Norris, R. P.; Pearce, S. E.; Phillips, C.; Pilawa, M. A.; Raja, W.; Reynolds, J. E.; Roberts, P.; Roxby, D. N.; Sadler, E. M.; Shields, M.; Schinckel, A. E. T.; Serra, P.; Shaw, R. D.; Sweetnam, T.; Troup, E. R.; Tzioumis, A.; Voronkov, M. A.; Westmeier, T. "Australian square kilometre array pathfinder. I. system description" *Publications of the Astronomical Society of Australia*, 38 :e009, 2021.
- Hsieh, Cheng-Han; Arce, Héctor G.; Mardones, Diego; Kong, Shuo; Plunkett, Adele "Rotating Filament in Orion B: Do Cores Inherit Their Angular Momentum from Their Parent Filament?" *The Astrophysical Journal*, 908 :92, 2021.
- Hsieh, Pei-Ying; Koch, Patrick M.; Kim, Woong-Tae; Martín, Sergio; Yen, Hsi-Wei; Carpenter, John M.; Harada, Nanase; Turner, Jean L.; Ho, Paul T. P.; Tang, Ya-Wen; Beck, Sara "The Circumnuclear Disk Revealed by ALMA. I. Dense Clouds and Tides in the Galactic Center" *The Astrophysical Journal*, 913 :94, 2021.
- Huang, Jane; Bergin, Edwin A.; Öberg, Karin I.; Andrews, Sean M.; Teague, Richard; Law, Charles J.; Kalas, Paul; Aikawa, Yuri; Bae, Jaehan; Bergner, Jennifer B.; Booth, Alice S.; Bosman, Arthur D.; Calahan, Jenny K.; Cataldi, Gianni; Cleeves, L. Ilse; Czekala, Ian; Ilee, John D.; Le Gal, Romane; Guzmán, Viviana V.; Long, Feng; Loomis, Ryan A.; Ménard, François; Nomura, Hideko; Qi, Chunhua; Schwarz, Kamber R.; Tsukagoshi, Takashi; Van'T Hoff, Merel L. R.; Walsh, Catherine; Wilner, David J.; Yamato, Yoshihide; Zhang, Ke "Molecules with ALMA at Planet-forming Scales (MAPS). XIX. Spiral Arms, a Tail, and Diffuse Structures Traced by CO around the GM Aur Disk" *The Astrophysical Journal Supplement Series*, 257 :19, 2021.
- Huang, Yun; Lee, Kyoung-Soo; Shi, Ke; Malavasi, Nicola; Xue, Rui; Dey, Arjun "The Role of Dust, UV Luminosity and Large-scale Environment on the Escape of Ly $\alpha$  Photons: A Case Study of a Protocluster Field at  $z = 3.1$ " *The Astrophysical Journal*, 921 :4, 2021.
- Hughes, A. G.; Boley, A. C.; Osten, R. A.; White, J. A.; Leacock, M. "Unlocking the Origins of Ultracool Dwarf Radio Emission" *The Astronomical Journal*, 162 :43, 2021.
- Hunt, Gareth; Schwab, Frederic R.; Henning, P. A.; Bailer, Dana S. "Gender Systematics in the NRAO Proposal Review System" *Publications of the Astronomical Society of the Pacific*, 133 :115002, 2021.
- Hunt, Lucas R.; Johnson, Megan C.; Cigan, Phillip J.; Gordon, David; Spitzak, John "Imaging Sources in the Third Realization of the International Celestial Reference Frame" *The Astronomical Journal*, 162 :121, 2021.
- Hunter, Deidre A.; Elmegreen, Bruce G.; Archer, Haylee; Simpson, Caroline E.; Cigan, Phil "A Search for Correlations between Turbulence and Star Formation in LITTLE THINGS Dwarf Irregular Galaxies" *The Astronomical Journal*, 161 :175, 2021.
- Hunter, Deidre A.; Elmegreen, Bruce G.; Goldberger, Esther; Taylor, Hannah; Ermakov, Anton I.; Herrmann, Kimberly A.; Oh, Se-Heon; Malko, Bradley; Barandi, Brian; Jundt, Ryan "Relationships between the Stellar, Gaseous, and Star Formation Disks in LITTLE THINGS Dwarf Irregular Galaxies: Indirect Evidence for Substantial Fractions of Dark Molecular Gas" *The Astronomical Journal*, 161 :71, 2021.
- Hunter, T. R.; Brogan, C. L.; De Buizer, J. M.; Townner, A. P. M.; Dowell, C. D.; Macleod, G. C.; Stecklum, B.; Cyganowski, C. J.; El-Abd, S. J.; Mcguire, B. A. "The Extraordinary Outburst in the Massive Protostellar System NGC 6334 I-MM1: Strong Increase in Mid-Infrared Continuum Emission" *The Astrophysical Journal*, 912 :L17, 2021.
- Hwang, Yu-Hsuan; Wang, Wei-Hao; Chang, Yu-Yen; Lim, Chen-Fatt; Chen, Chian-Chou; Gao, Zhen-Kai; Dunlop, James S.; Gao, Yu; Ho, Luis C.; Hwang, Ho Seong; Koprowski, Maciej; Michałowski, Michał J.; Peng, Ying-Jie; Shim, Hyunjin; Simpson, James M.; Toba, Yoshiki "Revisiting the Color-Color Selection: Submillimeter and AGN Properties of NUV-r-J Selected Quiescent Galaxies" *The Astrophysical Journal*, 913 :6, 2021.
- Hyman, S. D.; Frail, D. A.; Deneva, J. S.; Kassim, N. E.; Giacintucci, S.; Kooi, J. E.; Lazio, T. J. W.; Joyner, I.; Peters, W. M.; Gajjar, V.; Siemion, A. P.

- V. "Two extreme steep-spectrum, polarized radio sources towards the galactic bulge" *Monthly Notices of the Royal Astronomical Society*, 507 :3888, 2021.
- Ichikawa, Takanori; Kido, Miyu; Takaishi, Daisuke; Shimajiri, Yoshito; Tsukamoto, Yusuke; Takakuwa, Shigehisa "Misaligned Circumstellar Disks and Orbital Motion of the Young Binary XZ Tau" *The Astrophysical Journal*, 919 :55, 2021.
- Ighina, L.; Belladitta, S.; Caccianiga, A.; Broderick, J. W.; Drouart, G.; Moretti, A.; Seymour, N. "Radio detection of VIK J2318 3113, the most distant radio-loud quasar ( $z = 6.44$ )" *Astronomy and Astrophysics*, 647 :L11, 2021.
- Iino, Takahiro; Taniguchi, Kotomi; Sagawa, Hideo; Tsukagoshi, Takashi "13C Isotopic Ratios of HC3N on Titan Measured with ALMA" *The Planetary Science Journal*, 2 :166, 2021.
- Ilee, John D.; Walsh, Catherine; Booth, Alice S.; Aikawa, Yuri; Andrews, Sean M.; Bae, Jaehan; Bergin, Edwin A.; Bergner, Jennifer B.; Bosman, Arthur D.; Cataldi, Gianni; Cleeves, L. I.; Ilesedore, Czekala, Ian; Guzmán, Viviana V.; Huang, Jane; Law, Charles J.; Le Gal, Romane; Loomis, Ryan A.; Ménard, François; Nomura, Hideko; Öberg, Karin I.; Qi, Chunhua; Schwarz, Kamber R.; Teague, Richard; Tsukagoshi, Takashi; Wilner, David J.; Yamato, Yoshihide; Zhang, Ke "Molecules with ALMA at Planet-forming Scales (MAPS). IX. Distribution and Properties of the Large Organic Molecules HC3N, CH3CN, and c-C3H2" *The Astrophysical Journal Supplement Series*, 257 :9, 2021.
- Ilyushin, V. V.; Margulès, L.; Terceso, B.; Motiyenko, R. A.; Dorovskaya, O.; Alekseev, E. A.; Alonso, E. R.; Kolesniková, L.; Cernicharo, J.; Guillemin, J. C. "Submillimeter wave spectroscopy of propanoic acid (CH3CH2COOH) and its ISM search" *Journal of Molecular Spectroscopy*, 379 :111454, 2021.
- Imanishi, Masatoshi; Hagiwara, Yoshiaki; Horiuchi, Shinji; Izumi, Takuma; Nakanishi, Kouichiro "ALMA detection of millimetre 183 GHz H2O maser emission in the Superantennae galaxy at  $z = 0.06$ " *Monthly Notices of the Royal Astronomical Society*, 502 :L79, 2021.
- Inoue, Shigeki; Takagi, Toshinobu; Miyazaki, Atsushi; Cooper, Erin Mentuch; Egusa, Fumi; Yajima, Hidenobu "Instability analysis for spiral arms of local galaxies: M51, NGC 3627, and NGC 628" *Monthly Notices of the Royal Astronomical Society*, 506 :84, 2021.
- Isequilla, N. L.; Ortega, M. E.; Areal, M. B.; Paron, S. "Multiple molecular outflows and fragmentation in the IRDC core G34.43+00.24 MM1" *Astronomy and Astrophysics*, 649 :A139, 2021.
- Issaoun, S.; Johnson, M. D.; Blackburn, L.; Broderick, A.; Tiede, P.; Wielgus, M.; Doleman, S. S.; Falcke, H.; Akiyama, K.; Bower, G. C.; Brinkerink, C. D.; Chael, A.; Cho, I.; Gómez, J. L.; Hernández-Gómez, A.; Hughes, D.; Kino, M.; Krichbaum, T. P.; Liuzzo, E.; Loinard, L.; Markoff, S.; Marrone, D. P.; Mizuno, Y.; Moran, J. M.; Pidopryhora, Y.; Ros, E.; Rygl, K.; Shen, Z.-Q.; Wagner, J. "Persistent Non-Gaussian Structure in the Image of Sagittarius A\* at 86 GHz" *The Astrophysical Journal*, 915 :99, 2021.
- Izumi, Takuma; Matsuoka, Yoshiki; Fujimoto, Seiji; Onoue, Masafusa; Strauss, Michael A.; Umehata, Hideki; Imanishi, Masatoshi; Kohno, Kotaro; Kawaguchi, Toshihiro; Kawamuro, Taiki; Baba, Shunsuke; Nagao, Tohru; Toba, Yoshiki; Inayoshi, Kohei; Silverman, John D.; Inoue, Akio K.; Ikarashi, Soh; Iwasawa, Kazushi; Kashikawa, Nobunari; Hashimoto, Takuya; Nakanishi, Kouichiro; Ueda, Yoshihiro; Schramm, Malte; Lee, Chien-Hsiu; Suh, Hyewon "Subaru High-z Exploration of Low-luminosity Quasars (SHELLQs). XIII. Large-scale Feedback and Star Formation in a Low-luminosity Quasar at  $z = 7.07$  on the Local Black Hole to Host Mass Relation" *The Astrophysical Journal*, 914 :36, 2021.
- Izumi, Takuma; Onoue, Masafusa; Matsuoka, Yoshiki; Strauss, Michael A.; Fujimoto, Seiji; Umehata, Hideki; Imanishi, Masatoshi; Kawamuro, Taiki; Nagao, Tohru; Toba, Yoshiki; Kohno, Kotaro; Kashikawa, Nobunari; Inayoshi, Kohei; Kawaguchi, Toshihiro; Iwasawa, Kazushi; Inoue, Akio K.; Goto, Tomotsugu; Baba, Shunsuke; Schramm, Malte; Suh, Hyewon; Harikane, Yuichi; Ueda, Yoshihiro; Silverman, John D.; Hashimoto, Takuya; Hashimoto, Yasuhiro; Ikarashi, Soh; Iono, Daisuke; Lee, Chien-Hsiu; Lee, Kianhong; Minezaki, Takeo; Nakanishi, Kouichiro; Nakano, Suzuka; Tamura, Yoichi; Tang, Ji-Jia "Subaru High-z Exploration of Low-luminosity Quasars (SHELLQs). XII. Extended [C II] Structure (Merger or Outflow) in a  $z = 6.72$  Red Quasar" *The Astrophysical Journal*, 908 :235, 2021.
- Jacob, Arshia M.; Menten, Karl M.; Wiesemeyer, Helmut; Ortiz-León, Gisela N. "The CH radical at radio wavelengths: revisiting emission in the 3.3 GHz ground-state lines" *Astronomy and Astrophysics*, 650 :A133, 2021.
- Jafarzadeh, S.; Wedemeyer, S.; Fleck, B.; Stangalini, M.; Jess, D. B.; Morton, R. J.; Szydlarski, M.; Henriques, V. M. J.; Zhu, X.; Wiegmann, T.; Guevara Gómez, J. C.; Grant, S. D. T.; Chen, B.; Reardon, K.; White, S. M. "An overall view of temperature oscillations in the solar chromosphere with ALMA" *Royal Society of London Philosophical Transactions Series A*, 379 :20200174, 2021.
- James, Tomas A.; Viti, Serena; Yusef-Zadeh, Farhad; Royster, Marc; Wardle, Mark "Revealing the Physical Conditions around Sgr A\* Using Bayesian Inference. I. Observations and Radiative Transfer" *The Astrophysical Journal*, 916 :69, 2021.
- Janssen, Michael; Falcke, Heino; Kadler, Matthias; Ros, Eduardo; Wielgus, Maciek; Akiyama, Kazunori; Baloković, Mislav; Blackburn, Lindy; Bouman, Katherine L.; Chael, Andrew; Chan, Chi-Kwan; Chatterjee, Koushik; Davelaar, Jordy; Edwards, Philip G.; Fromm, Christian M.; Gómez, José L.; Goddi, Ciriaco; Issaoun, Sara; Johnson, Michael D.; Kim, Junhan; Koay, Jun Yi; Krichbaum, Thomas P.; Liu, Jun; Liuzzo, Elisabetta; Markoff, Sera; Markowitz, Alex; Marrone, Daniel P.; Mizuno, Yosuke; Müller, Cornelia; Ni, Chunhong; Pesce, Dominic W.; Ramakrishnan, Venkatesh; Roelofs, Freek; Rygl, Kazi L. J.; Van Bemmelen, Ilse; Event Horizon Telescope Collaboration; Alberdi, Anton; Alef, Walter; Algaba, Juan Carlos; Anantua, Richard; Asada, Keichi; Azulay, Rebecca; Baccko, Anne-Kathrin; Ball, David; Ball, David; Barrett, John; Benson, Bradford A.; Bintley, Dan; Bintley, Dan; Blundell, Raymond; Boland, Wilfred; Boland, Wilfred; Bower, Geoffrey C.; Boyce, Hope; Bremer, Michael; Brinkerink, Christiaan D.; Brissenden, Roger; Britzen, Silke; Broderick, Avery E.; Brogiere, Dominique; Bronzwaer, Thomas; Byun, Do-Young; Carlstrom, John E.; Chatterjee, Shami; Chen, Ming-Tang; Chen, Yongjun; Chesler, Paul M.; Cho, Ilje; Christian, Pierre; Conway, John E.; Cordes, James M.; Crawford, Thomas M.; Crew, Geoffrey B.; Cruz-Osorio, Alejandro; Cui, Yuzhu; Cui, Yuzhu; De Laurentis, Mariafelicia; Deane, Roger; Dempsey, Jessica; Desvignes, Gregory; Dexter, Jason; Doleman, Sheperd S.; Eatough, Ralph P.; Farah, Joseph; Farah, Joseph; Fish, Vincent L.; Fomalont, Ed; Ford, H. Alyson; Fraga-Encinas, Raquel; Friberg, Per; Friberg, Per; Fuentes, Antonio; Galison, Peter; Gammie, Charles F.; García, Roberto; Gelles, Zachary; Gentaz, Olivier; Georgiev, Boris; Georgiev, Boris; Gold, Roman; Gold, Roman; Gómez-Ruiz, Arturo I.; Gu, Minfeng; Gurwell, Mark; Hada, Kazuhiro; Haggard, Daryl; Hecht, Michael H.; Hesper, Ronald; Himwich, Elizabeth; Ho, Luis C.; Ho, Paul; Honma, Mareki; Huang, Chih-Wei L.; Huang, Lei; Hughes, David H.; Ikeda, Shiro; Inoue, Makoto; Inoue, Makoto; James, David J.; Jannuzi, Buell T.; Jannuzi, Buell T.; Jeter, Britton; Jiang, Wu; Jimenez-Rosales, Alejandra; Jimenez-Rosales, Alejandra; Jorstad, Svetlana; Jung, Taehyun; Karami, Mansour; Karuppusamy, Ramesh; Kawashima, Tomohisa; Keating, Garrett K.; Kettenis, Mark; Kim, Dong-Jin; Kim, Jae-Young; Kim, Jae-Young; Kim, Jongsoo; Kino, Motoki; Kino, Motoki; Kofuji, Yutaro; Koyama, Shoko; Kramer, Michael; Kramer, Carsten; Kramer, Carsten; Kuo, Cheng-Yu; Lauer, Tod R.; Lee, Sang-Sung; Levis, Aviad; Li, Yan-Rong; Li, Zhiyuan; Lindqvist, Michael; Lico, Rocco; Lindahl, Greg; Lindahl, Greg; Liu, Kuo; Liu, Kuo; Lo, Wen-Ping; Lobanov, Andrei P.; Loinard, Laurent; Lonsdale, Colin; Lu, Ru-Sen; Macdonald, Nicholas R.; Mao, Jirong; Marchili, Nicola; Marchili, Nicola; Marchili, Nicola; Marscher, Alan P.; Martí-Vidal, Iván; Matsushita, Satoki; Matthews, Lynn D.; Medeiros, Lia; Menten, Karl M.; Mizuno, Izumi; Mizuno, Izumi; Moran, James M.; Moriyama, Kotaro; Moscibrodzka, Monika; Moscibrodzka, Monika; Musoke, Gibwa; Mejías, Alejandro Mus; Nagai, Hiroshi; Nagar, Neil

## APPENDIX A: PUBLICATIONS

- M.; Nakamura, Masanori; Narayan, Ramesh; Narayanan, Gopal; Natarajan, Iniyam; Nathanael, Antonios; Neilsen, Joey; Neri, Roberto; Neri, Roberto; Noutsos, Aristeidis; Nowak, Michael A.; Okino, Hiroki; Olivares, Héctor; Ortiz-León, Gisela N.; Oyama, Tomoaki; Özel, Feryal; Palumbo, Daniel C. M.; Park, Jongho; Patel, Nimesh; Pen, Ue-Li; Pen, Ue-Li; Piétu, Vincent; Plambeck, Richard; Popstefanija, Aleksandar; Porth, Oliver; Pötzl, Felix M.; Prather, Ben; Preciado-López, Jorge A.; Psaltis, Dimitrios; Pu, Hung-Yi; Pu, Hung-Yi; Rao, Ramprasad; Rawlings, Mark G.; Raymond, Alexander W.; Rezzolla, Luciano; Ricarte, Angelo; Ripperda, Bart; Ripperda, Bart; Rogers, Alan; Rogers, Alan; Rose, Mel; Roshanineshat, Arash; Rottmann, Helge; Roy, Alan L.; Ruszczyk, Chet; Ruszczyk, Chet; Sánchez, Salvador; Sánchez-Arguelles, David; Sasada, Mahito; Savolainen, Tuomas; Schloerb, F. Peter; Schuster, Karl-Friedrich; Shao, Lijing; Shen, Zhiqiang; Small, Des; Sohn, Bong Won; Soohoo, Jason; Sun, He; Tazaki, Fumie; Tetarenko, Alexandra J.; Tiede, Paul; Tilanus, Remo P. J.; Titus, Michael; Torne, Pablo; Trent, Tyler; Traianou, Eftalia; Trippe, Sascha; Van Bemmell, Ilse; Van Langevelde, Huib Jan; Van Rossum, Daniel R.; Wagner, Jan; Ward-Thompson, Derek; Wardle, John; Weintraub, Jonathan; Wex, Norbert; Wharton, Robert; Wharton, Robert; Wong, George N.; Wu, Qingwen; Yoon, Doosoo; Young, André; Young, Ken; Younsi, Ziri; Yuan, Feng; Yuan, Ye-Fei; Zensus, J. Anton; Zhao, Guang-Yao; Zhao, Shan-Shan "Event Horizon Telescope observations of the jet launching and collimation in Centaurus A" *Nature Astronomy*, 5 :1017-1028, 2021.
- Jaodand, Amruta D.; Deller, Adam T.; Gusinskaia, Nina; Hessels, Jason W. T.; Miller-Jones, James C. A.; Archibald, Anne M.; Bogdanov, Slavko; Bassa, Cees; Wijnands, Rudy; Patruno, Alessandro; Sanidas, Sotiris "Quasi-simultaneous Radio/X-Ray Observations of the Candidate Transitional Millisecond Pulsar 3FGL J1544.6-1125 during its Low-luminosity Accretion-disk State" *The Astrophysical Journal*, 923 :3, 2021.
- Jarugula, Sreevani; Vieira, Joaquin D.; Weiss, Axel; Spilker, Justin S.; Aravena, Manuel; Archipley, Melanie; Béthermin, Matthieu; Chapman, Scott C.; Dong, Chenxing; Greve, Thomas R.; Harrington, Kevin; Hayward, Christopher C.; Hezaveh, Yashar; Hill, Ryley; Litke, Katrina C.; Malkan, Matthew A.; Marrone, Daniel P.; Narayanan, Desika; Phadke, Kedar A.; Reuter, Cassie; Rotermund, Kaja M. "Molecular Line Observations in Two Dusty Star-forming Galaxies at  $z = 6.9$ " *The Astrophysical Journal*, 921 :97, 2021.
- Järvelä, Emilia; Berton, Marco; Crepaldi, Luca "Narrow-line Seyfert 1 galaxies with absorbed jets -insights from radio spectral index maps" *Frontiers in Astronomy and Space Sciences*, 8 :147, 2021.
- Jarvis, M. E.; Harrison, C. M.; Mainieri, V.; Alexander, D. M.; Arrigoni Battaia, F.; Calistro Rivera, G.; Circosta, C.; Costa, T.; De Breuck, C.; Edge, A. C.; Girdhar, A.; Kakkad, D.; Kharb, P.; Lansbury, G. B.; Molyneux, S. J.; Mukherjee, D.; Mullaney, J. R.; Farina, E. P.; Silpa, S.; Thomson, A. P.; Ward, S. R. "The quasar feedback survey: discovering hidden Radio-AGN and their connection to the host galaxy ionized gas" *Monthly Notices of the Royal Astronomical Society*, 503 :1780, 2021.
- Jensen, S. S.; Jørgensen, J. K.; Kristensen, L. E.; Coutens, A.; Van Dishoeck, E. F.; Furuya, K.; Harsono, D.; Persson, M. V. "ALMA observations of doubly deuterated water: inheritance of water from the prestellar environment" *Astronomy and Astrophysics*, 650 :A172, 2021.
- Jhan, Kai-Syun; Lee, Chin-Fei "25 au Angular Resolution Observations of HH 211 with ALMA: Jet Properties and Shock Structures in SiO, CO, and SO" *The Astrophysical Journal*, 909 :11, 2021.
- Ji, Xihan; Li, Cheng; Yan, Renbin; Mo, Houjun; Lin, Lihwai; Zou, Hu; Lian, Jianhui; Stark, David V.; Riffel, Rogemar A.; Pan, Hsi-An; Bizyaev, Dmitry; Bundy, Kevin "SDSS-IV MaNGA: The physical origin of off-galaxy H $\alpha$  blobs in the local Universe" *Monthly Notices of the Royal Astronomical Society*, 508 :3943-3966, 2021.
- Jiang, Wu; Shen, Zhiqiang; Martí-Vidal, Ivan; Wang, Xuezheng; Jiang, Dongrong; Kawaguchi, Noriyuki "Millimeter-VLBI Observations of Low-luminosity Active Galactic Nuclei with Source-frequency Phase Referencing" *The Astrophysical Journal*, 922 :L16, 2021.
- Jiao, Qian; Gao, Yu; Zhao, Yinghe "The Carbon-to-H $2$ , CO-to-H $2$  conversion factors, and carbon abundance on kiloparsec scales in nearby galaxies" *Monthly Notices of the Royal Astronomical Society*, 504 :2360, 2021.
- Jiménez-Andrade, E. F.; Murphy, E. J.; Heywood, I.; Smail, I.; Penner, K.; Momjian, E.; Dickinson, M.; Armus, L.; Lazio, T. J. W. "The VLA Frontier Field Survey: A Comparison of the Radio and UV/Optical Size of 0.3  $z \leq 3$  Star-forming Galaxies" *The Astrophysical Journal*, 910 :106, 2021.
- Jin, S.; Dannerbauer, H.; Emonts, B.; Serra, P.; Lagos, C. D. P.; Thomson, A. P.; Bassini, L.; Lehnert, M.; Allison, J. R.; Champagne, J. B.; Indermühle, B.; Norris, R. P.; Seymour, N.; Shimakawa, R.; Casey, C. M.; De Breuck, C.; Drouart, G.; Hatch, N.; Kodama, T.; Koyama, Y.; Macgregor, P.; Miley, G.; Overzier, R.; Pérez-Martínez, J. M.; Rodríguez-Espinosa, J. M.; Röttgering, H.; Sánchez Portal, M.; Ziegler, B. "COALAS. I. ATCA CO(1-0) survey and luminosity function in the Spiderweb protocluster at  $z = 2.16$ " *Astronomy and Astrophysics*, 652 :A11, 2021.
- Johnson, Michael D.; Kovalev, Yuri Y.; Lisakov, Mikhail M.; Voitsik, Petr A.; Gwinn, Carl R.; Bruni, Gabriele "First Space-VLBI Observations of Sagittarius A\*" *The Astrophysical Journal*, 922 :L28, 2021.
- Johnston, Ryan S.; Stil, Jeroen M.; Keller, Ben W. "Properties of Compact Faint Radio Sources as a Function of Angular Size from Stacking" *The Astrophysical Journal*, 909 :73, 2021.
- Jolly, Jean-Baptiste; Knudsen, Kirsten; Laporte, Nicolas; Richard, Johan; Fujimoto, Seiji; Kohno, Kotaro; Ao, Yiping; Bauer, Franz E.; Egami, Eiichi; Espada, Daniel; Dessauges-Zavadsky, Miroslava; Magdis, Georgios; Schaerer, Daniel; Sun, Fengwu; Valentino, Francesco; Wang, Wei-Hao; Zitrin, Adi "ALMA Lensing Cluster Survey: A spectral stacking analysis of [C II] in lensed  $z \leq 6$  galaxies" *Astronomy and Astrophysics*, 652 :A128, 2021.
- Jones, A.; De Gasperin, F.; Cuciti, V.; Hoang, D. N.; Botteon, A.; Brüggem, M.; Brunetti, G.; Finner, K.; Forman, W. R.; Jones, C.; Kraft, R. P.; Shimwell, T.; Van Weeren, R. J. "Radio relics in PSZ2 G096.88+24.18: a connection with pre-existing plasma" *Monthly Notices of the Royal Astronomical Society*, 505 :4762, 2021.
- Jones, G. C.; Vergani, D.; Romano, M.; Ginolfi, M.; Fudamoto, Y.; Béthermin, M.; Fujimoto, S.; Lemaux, B. C.; Morselli, L.; Capak, P.; Cassata, P.; Faist, A.; Le Fèvre, O.; Schaerer, D.; Silverman, J. D.; Yan, Lin; Boquien, M.; Cimatti, A.; Dessauges-Zavadsky, M.; Ibar, E.; Maiolino, R.; Rizzo, F.; Talia, M.; Zamorani, G. "The ALPINE-ALMA [C II] Survey: kinematic diversity and rotation in massive star-forming galaxies at  $z = 4.4-5.9$ " *Monthly Notices of the Royal Astronomical Society*, 507 :3540, 2021.
- Jones, M. L.; McLaughlin, M. A.; Roy, J.; Lam, M. T.; Cordes, J. M.; Kaplan, D. L.; Bhattacharyya, B.; Levin, L. "Evaluating Low-frequency Pulsar Observations to Monitor Dispersion with the Giant Metrewave Radio Telescope" *The Astrophysical Journal*, 915 :15, 2021.
- Jones, Michael G.; Bennet, Paul; Mutlu-Pakdil, Burçin; Sand, David J.; Spekkens, Kristine; Crnojević, Denija; Karunakaran, Ananthan; Zaritsky, Dennis "Evidence for Ultra-diffuse Galaxy Formation through Tidal Heating of Normal Dwarfs" *The Astrophysical Journal*, 919 :72, 2021.
- Józsa, Gyula I. G.; Thorat, Kshitij; Kamphuis, Peter; Sebokolodi, Lerato; Maina, Eric K.; Wang, Jing; Pieterse, Daniëlle L. A.; Groot, Paul; Ramaila, Athanaseus J. T.; Serra, Paolo; Andati, Lexy A. L.; De Blok, W. J. G.; Hugo, Benjamin V.; Kleiner, Dane; Maccagni, Filippo M.; Makhathini, Sphesihle; Molnár, Dániel Cs; Ramatsoku, Mpati; Smirnov, Oleg M.; Bloemen, Steven; Paterson, Kerry; Vreeswijk, Paul; McBride, Vanessa; Klein-Wolt, Marc; Woudt, Patrick; Körding, Elmar; Le Poole, Rudolf; Goedhart, Sharmila; Passmoor, Sean S.; Serylak, Maciej; Dettmar, Ralf-Jürgen "Anomalous gas in ESO 149-G003: a MeerKAT-16 view" *Monthly Notices of the Royal Astronomical Society*, 501 :2704, 2021.
- Juarez, A.; Fernández, L. I. "Retrasos troposféricos VLBI estimados con VieVs durante CONT11 y CONT17" *Boletín de la Asociación Argentina de Astronomía La Plata Argentina*, 62 :289, 2021.
- Jung, S. Lyla; McClure-Griffiths, N. M.; Hill, Alex S. "Distant probes of rotation measure structure: where is the Faraday rotation towards the

- Magellanic Leading Arm?" *Monthly Notices of the Royal Astronomical Society*, 508 :3921, 2021.
- Jurlin, N.; Brienza, M.; Morganti, R.; Wadadekar, Y.; Ishwara-Chandra, C. H.; Maddox, N.; Mahatma, V. "Multi-frequency characterisation of remnant radio galaxies in the Lockman Hole field" *Astronomy and Astrophysics*, 653 :A110, 2021.
- Kader, Justin A.; Van Zee, Liese; Mcquinn, Kristen B. W.; Hunter, Laura C. "Anomalous H $\alpha$  Emission Line Profile Detected at the Center of DDO 53" *The Astrophysical Journal*, 919 :73, 2021.
- Kalita, Boris S.; Daddi, Emanuele; Coogan, Rosemary T.; Delvecchio, Ivan; Gobat, Raphael; Valentino, Francesco; Strazzullo, Veronica; Tremou, Evangelia; Gómez-Guijarro, Carlos; Elbaz, David; Finoguenov, Alexis "Feedback factory: multiple faint radio jets detected in a cluster at  $z = 2$ " *Monthly Notices of the Royal Astronomical Society*, 503 :1174, 2021.
- Kalita, Boris S.; Daddi, Emanuele; Chiarra, Valentino; Francesco; Rich, R. Michael; Gómez-Guijarro, Carlos; Coogan, Rosemary T.; Delvecchio, Ivan; Elbaz, David; Neill, James D.; Puglisi, Annagrazia; Strazzullo, Veronica "An Ancient Massive Quiescent Galaxy Found in a Gas-rich  $z > 3$  Group" *The Astrophysical Journal*, 917 :L17, 2021.
- Kamiński, T.; Steffen, W.; Bujarrabal, V.; Tylenda, R.; Menten, K. M.; Hajduk, M. "Molecular remnant of Nova 1670 (CK Vulpeculae). II. A three-dimensional view of the gas distribution and velocity field" *Astronomy and Astrophysics*, 646 :A1, 2021.
- Kamiński, Tomek; Tylenda, Romuald; Kiljan, Aleksandra; Schmidt, Mirek; Lisiecki, Krzysztof; Melis, Carl; Frankowski, Adam; Joshi, Vishal; Menten, Karl M. "V838 Monocerotis as seen by ALMA: A remnant of a binary merger in a triple system" *Astronomy and Astrophysics*, 655 :A32, 2021.
- Kanagawa, Kazuhiro D.; Hashimoto, Jun; Muto, Takayuki; Tsukagoshi, Takashi; Takahashi, Sanemichi Z.; Hasegawa, Yasuhiro; Konishi, Mihoko; Nomura, Hideko; Liu, Haiyu Baobab; Dong, Ruobing; Kataoka, Akimasa; Momose, Munetake; Ono, Tomohiro; Sitko, Michael; Takami, Michihiro; Tomida, Kengo "ALMA Observation of the Protoplanetary Disk around WW Cha: Faint Double-peaked Ring and Asymmetric Structure" *The Astrophysical Journal*, 909 :212, 2021.
- Kanekar, N.; Ghosh, T.; Rhoads, J.; Malhotra, S.; Harish, S.; Chengalur, J. N.; Jones, K. M. "The Atomic Gas Mass of Green Pea Galaxies" *The Astrophysical Journal*, 913 :L15, 2021.
- Kang, S.; Lee, S.-S.; Hodgson, J.; Algaba, J.-C.; Lee, J. W.; Kim, J.-Y.; Park, J.; Kino, M.; Kim, D.; Trippé, S. "Interferometric monitoring of gamma-ray bright AGNs: Measuring the magnetic field strength of 4C +29.45" *Astronomy and Astrophysics*, 651 :A74, 2021.
- Kaur, B.; Kanekar, N.; Rafelski, M.; Neeleman, M.; Revalski, M.; Prochaska, J. X. "The Nature of HI-absorption-selected Galaxies at  $z \sim 4$ " *The Astrophysical Journal*, 921 :68, 2021.
- Kavak, Ü.; Sánchez-Monge, Á.; López-Sepulcre, A.; Cesaroni, R.; Van Der Tak, F. F. S.; Moscadelli, L.; Beltrán, M. T.; Schilke, P. "Search for radio jets from massive young stellar objects. Association of radio jets with H $_2$ O and CH $_3$ OH masers" *Astronomy and Astrophysics*, 645 :A29, 2021.
- Kawamuro, Taiki; Ricci, Claudio; Izumi, Takuma; Imanishi, Masatoshi; Baba, Shunsuke; Nguyen, Dieu D.; Onishi, Kyoko "Hard X-Ray Irradiation Potentially Drives Negative AGN Feedback by Altering Molecular Gas Properties" *The Astrophysical Journal Supplement Series*, 257 :64, 2021.
- Keenan, Mary; Meyer, Eileen T.; Georganopoulos, Markos; Reddy, Karthik; French, Omar J. "The relativistic jet dichotomy and the end of the blazar sequence" *Monthly Notices of the Royal Astronomical Society*, 505 :4726, 2021.
- Kharb, P.; Subramanian, S.; Das, M.; Vaddi, S.; Paragi, Z. "The Nature of Jets in Double-peaked Emission-line AGN in the KISSR Sample" *The Astrophysical Journal*, 919 :108, 2021.
- Khatiwada, R.; Bowring, D.; Chou, A. S.; Sonnenschein, A.; Wester, W.; Mitchell, D. V.; Braine, T.; Bartram, C.; Cervantes, R.; Crisosto, N.; Du, N.; Rosenberg, L. J.; Rybka, G.; Yang, J.; Will, D.; Kimes, S.; Carosi, G.; Woollett, N.; Durham, S.; Duffy, L. D.; Bradley, R.; Boutan, C.; Jones, M.; Laroque, B. H.; Oblath, N. S.; Taubman, M. S.; Tedeschi, J.; Clarke, John; Dove, A.; Hashim, A.; Siddiqi, I.; Stevenson, N.; Eddins, A.; O'Kelley, S. R.; Nawaz, S.; Agrawal, A.; Dixit, A. V.; Gleason, J. R.; Jois, S.; Sikivie, P.; Sullivan, N. S.; Tanner, D. B.; Solomon, J. A.; Lentz, E.; Daw, E. J.; Perry, M. G.; Buckley, J. H.; Harrington, P. M.; Henriksen, E. A.; Murch, K. W.; Hilton, G. C. "Axion Dark Matter Experiment: Detailed design and operations" *Review of Scientific Instruments*, 92 :124502, 2021.
- Khorunzhev, G. A.; Meshcheryakov, A. V.; Medvedev, P. S.; Borisov, V. D.; Burenin, R. A.; Krivonos, R. A.; Uklein, R. I.; Shablovinskaya, E. S.; Afanasiev, V. L.; Dodonov, S. N.; Sunyaev, R. A.; Sazonov, S. Yu.; Gilfanov, M. R. "Discovery of the Most X-ray Luminous Quasar SRGE J170245.3+130104 at Redshift  $z \approx 5.5$ " *Astronomy Letters*, 47 :123, 2021.
- Khusanova, Y.; Bethermin, M.; Le Fèvre, O.; Capak, P.; Faist, A. L.; Schaerer, D.; Silverman, J. D.; Cassata, P.; Yan, L.; Ginolfi, M.; Fudamoto, Y.; Loiacono, F.; Amorin, R.; Bardelli, S.; Boquien, M.; Cimatti, A.; Dessauges-Zavadsky, M.; Gruppioni, C.; Hathi, N. P.; Jones, G. C.; Koekemoer, A. M.; Lagache, G.; Maiolino, R.; Lemaux, B. C.; Oesch, P.; Pozzi, F.; Riechers, D. A.; Romano, M.; Talia, M.; Toft, S.; Vergani, D.; Zamorani, G.; Zucca, E. "The ALPINE-ALMA [CII] survey. Obscured star formation rate density and main sequence of star-forming galaxies at  $z > 4$ " *Astronomy and Astrophysics*, 649 :A152, 2021.
- Kim, Jaeyeon; Chevance, Mélanie; Kruijssen, J. M. Diederik; Schruha, Andreas; Sandstrom, Karin; Barnes, Ashley T.; Bigiel, Frank; Blanc, Guillermo A.; Cao, Yixian; Dale, Daniel A.; Faesi, Christopher M.; Glover, Simon C. O.; Grasha, Kathryn; Groves, Brent; Herrera, Cinthya; Klessen, Ralf S.; Kreckel, Kathryn; Lee, Janice C.; Leroy, Adam K.; Pety, Jérôme; Querejeta, Miguel; Schinnerer, Eva; Sun, Jiayi; Usero, Antonio; Ward, Jacob L.; Williams, Thomas G. "On the duration of the embedded phase of star formation" *Monthly Notices of the Royal Astronomical Society*, 504 :487, 2021.
- Kimbro, Erin; Reines, Amy E.; Molina, Mallory; Deller, Adam T.; Stern, Daniel "Clumpy Star Formation and AGN Activity in the Dwarf-Dwarf Galaxy Merger Mrk 709" *The Astrophysical Journal*, 912 :89, 2021.
- Kino, Motoki; Niinuma, Kotaro; Kawakatu, Nozomu; Nagai, Hiroshi; Giovannini, Gabriele; Orienti, Monica; Wajima, Kiyooki; D'Ammando, Filippo; Hada, Kazuhiro; Giroletti, Marcello; Gurwell, Mark "Morphological Transition of the Compact Radio Lobe in 3C 84 via the Strong Jet-Cloud Collision" *The Astrophysical Journal*, 920 :L24, 2021.
- Klitsch, Anne; Péroux, Céline; Zwaan, Martin A.; De Cia, Annalisa; Ledoux, Cédric; Lopez, Sebastian "H $_2$  molecular gas absorption-selected systems trace CO molecular gas-rich galaxy overdensities" *Monthly Notices of the Royal Astronomical Society*, 506 :514, 2021.
- Klusmeyer, Jessica; Hughes, A. Meredith; Matrà, Luca; Flaherty, Kevin; Kóspál, Ágnes; Moór, Attila; Roberge, Aki; Öberg, Karin; Boley, Aaron; White, Jacob; Wilner, David; Ábrahám, Péter "A Deep Search for Five Molecules in the 49 Ceti Debris Disk" *The Astrophysical Journal*, 921 :56, 2021.
- Knowles, Kenda; Manaka, Sinah; Bietenholz, Michael F.; Cotton, William D.; Hilton, Matthew; Kolokythas, Konstantinos; Loubser, S. Ilani; Oozeer, Nadeem "Searching for High- $z$  Radio Galaxies with the MGCLS" *Galaxies*, 9 :89, 2021.
- Koch, Eric W.; Rosolowsky, Erik W.; Leroy, Adam K.; Chastenet, Jérémy; Chiang, I.-Da; Dalcanton, Julianne; Kepley, Amanda A.; Sandstrom, Karin M.; Schruha, Andreas; Stanimirović, Snežana; Utomo, Dyas; Williams, Thomas G. "A lack of constraints on the cold opaque H I mass: H I spectra in M31 and M33 prefer multi-component models over a single cold opaque component" *Monthly Notices of the Royal Astronomical Society*, 504 :1801, 2021.
- Kocherlakota, Prashant; Rezzolla, Luciano; Falcke, Heino; Fromm, Christian M.; Kramer, Michael; Mizuno, Yosuke; Nathanail, Antonios; Olivares, Héctor; Younsi, Ziri; Akiyama, Kazunori; Alberdi, Antxon; Alef, Walter;

## APPENDIX A: PUBLICATIONS

- Algaba, Juan Carlos; Anantua, Richard; Asada, Keiichi; Azulay, Rebecca; Baczko, Anne-Kathrin; Ball, David; Baloković, Mislav; Barrett, John; Benson, Bradford A.; Bintley, Dan; Blackburn, Lindy; Blundell, Raymond; Boland, Wilfred; Bouman, Katherine L.; Bower, Geoffrey C.; Boyce, Hope; Bremer, Michael; Brinkerink, Christiaan D.; Brissenden, Roger; Britzen, Silke; Broderick, Avery E.; Brogiere, Dominique; Bronzwaer, Thomas; Byun, Do-Young; Carlstrom, John E.; Chael, Andrew; Chan, Chi-Kwan; Chatterjee, Shami; Chatterjee, Koushik; Chen, Ming-Tang; Chen, Yongjun; Chesler, Paul M.; Cho, Ilje; Christian, Pierre; Conway, John E.; Cordes, James M.; Crawford, Thomas M.; Crew, Geoffrey B.; Cruz-Osorio, Alejandro; Cui, Yuzhu; Davelaar, Jordy; De Laurentis, Mariafelicia; Deane, Roger; Dempsey, Jessica; Desvignes, Gregory; Doeleman, Sheperd S.; Eatough, Ralph P.; Farah, Joseph; Fish, Vincent L.; Fomalont, Ed; Fraga-Encinas, Raquel; Friberg, Per; Ford, H. Alyson; Fuentes, Antonio; Galison, Peter; Gammie, Charles F.; García, Roberto; Gentaz, Olivier; Georgiev, Boris; Goddi, Ciriaco; Gold, Roman; Gómez, José L.; Gómez-Ruiz, Arturo I.; Gu, Minfeng; Gurwell, Mark; Hada, Kazuhiro; Haggard, Daryl; Hecht, Michael H.; Hesper, Ronald; Ho, Luis C.; Ho, Paul; Honma, Mareki; Huang, Chih-Wei L.; Huang, Lei; Hughes, David H.; Ikeda, Shiro; Inoue, Makoto; Issaoui, Sara; James, David J.; Jannuzi, Buell T.; Janssen, Michael; Jeter, Britton; Jiang, Wu; Jimenez-Rosales, Alejandra; Johnson, Michael D.; Jorstad, Svetlana; Jung, Taehyun; Karami, Mansour; Karuppusamy, Ramesh; Kawashima, Tomohisa; Keating, Garrett K.; Kettenis, Mark; Kim, Dong-Jin; Kim, Jae-Young; Kim, Jongsoo; Kim, Junhan; Kino, Motoki; Koay, Jun Yi; Kofuji, Yutarō; Koch, Patrick M.; Koyama, Shoko; Kramer, Carsten; Krichbaum, Thomas P.; Kuo, Cheng-Yu; Lauer, Tod R.; Lee, Sang-Sung; Levis, Aviad; Li, Yan-Rong; Li, Zhiyuan; Lindqvist, Michael; Lico, Rocco; Lindahl, Greg; Liu, Jun; Liu, Kuo; Liuzzo, Elisabetta; Lo, Wen-Ping; Lobanov, Andrei P.; Loinard, Laurent; Lonsdale, Colin; Lu, Ru-Sen; Macdonald, Nicholas R.; Mao, Jirong; Marchili, Nicola; Markoff, Sera; Marrone, Daniel P.; Marscher, Alan P.; Martí-Vidal, Iván; Matsushita, Satoki; Matthews, Lynn D.; Medeiros, Lia; Menten, Karl M.; Mizuno, Izumi; Moran, James M.; Moriyama, Kotaro; Moscibrodzka, Monika; Müller, Cornelia; Musoke, Gibwa; Mejías, Alejandro Mus; Nagai, Hiroshi; Nagar, Neil M.; Nakamura, Masanori; Narayan, Ramesh; Narayanan, Gopal; Natarajan, Iniyani; Neilsen, Joseph; Neri, Roberto; Ni, Chunhong; Noutsos, Aristeidis; Nowak, Michael A.; Okino, Hiroki; Ortiz-León, Gisela N.; Oyama, Tomoaki; Özel, Feryal; Palumbo, Daniel C. M.; Park, Jongho; Patel, Nimesh; Pen, Ue-Li; Pesce, Dominic W.; Piétu, Vincent; Plambeck, Richard; Popstefanija, Aleksandar; Porth, Oliver; Pötzl, Felix M.; Prather, Ben; Preciado-López, Jorge A.; Psaltis, Dimitrios; Pu, Hung-Yi; Ramakrishnan, Venkatesh; Rao, Ramprasad; Rawlings, Mark G.; Raymond, Alexander W.; Ricarte, Angelo; Ripperda, Bart; Roelofs, Freek; Rogers, Alan; Ros, Eduardo; Rose, Mel; Roshanineshat, Arash; Rottmann, Helge; Roy, Alan L.; Ruszczyk, Chet; Rygl, Kazi L. J.; Sánchez, Salvador; Sánchez-Arguelles, David; Sasada, Mahito; Savolainen, Tuomas; Schloerb, F. Peter; Schuster, Karl-Friedrich; Shao, Lijing; Shen, Zhiqiang; Small, Des; Sohn, Bong Won; Soohoo, Jason; Sun, He; Tazaki, Fumie; Tetarenko, Alexandra J.; Tiede, Paul; Tilanus, Remo P. J.; Titus, Michael; Toma, Kenji; Torne, Pablo; Trent, Tyler; Traianou, Efthalia; Trippe, Sascha; Van Bemmell, Ilse; Van Langevelde, Huib Jan; Van Rossum, Daniel R.; Wagner, Jan; Ward-Thompson, Derek; Wardle, John; Weintraub, Jonathan; Wex, Norbert; Wharton, Robert; Wielgus, Maciek; Wong, George N.; Wu, Qingwen; Yoon, Doosoo; Young, André; Young, Ken; Yuan, Feng; Yuan, Ye-Fei; Zensus, J. Anton; Zhao, Guang-Yao; Zhao, Shan-Shan; Eht Collaboration "Constraints on black-hole charges with the 2017 EHT observations of M87" *Physical Review D*, 103 :104047, 2021.
- Koga, Ryoichi; Suzuki, Tatsuya; Tsuchiya, Fuminori; Sakanoi, Takeshi; Hirahara, Yasuhiro "ALMA Observation of SO<sub>2</sub> Gas Originating from Io's Volcanic Plume and Lava Areas" *The Astrophysical Journal*, 907 :L6, 2021.
- Koley, Atanu; Roy, Nirupam; Menten, Karl M.; Jacob, Arshia M.; Pillai, Thushara G. S.; Rugel, Michael R. "The magnetic field in the dense photodissociation region of DR 21" *Monthly Notices of the Royal Astronomical Society*, 501 :4825, 2021.
- Koljonen, K. I. I.; Hovatta, T. "ALMA/NICER observations of GRS 1915+105 indicate a return to a hard state" *Astronomy and Astrophysics*, 647 :A173, 2021.
- Kollatschny, W.; Meusinger, H.; Hoefft, M.; Hill, G. J.; Ochmann, M. W.; Zeimann, G.; Froebrich, D.; Bhagat, S. "A galaxy cluster in the innermost Zone of Avoidance, close to the radio phoenix VLSS J2217.5+5943" *Astronomy and Astrophysics*, 652 :A24, 2021.
- Kondo, Hiroshi; Tokuda, Kazuki; Muraoka, Kazuyuki; Nishimura, Atsushi; Fujita, Shinji; Tosaki, Tomoka; Zahorec, Sarolta; Miura, Rie E.; Kobayashi, Masato I. N.; Onodera, Sachiko; Torii, Kazufumi; Kuno, Nario; Sano, Hidetoshi; Onishi, Toshikazu; Saigo, Kazuya; Fukui, Yasuo; Kawamura, Akiko; Tsuge, Kisetu; Tachihara, Kengo "ALMA Observations of Giant Molecular Clouds in M33. III. Spatially Resolved Features of the Star formation Inactive Million-solar-mass Cloud" *The Astrophysical Journal*, 912 :66, 2021.
- Kong, Shuo; Arce, Héctor G.; Shirley, Yancy; Glasgow, Colton "Evidence of Core Growth in the Dragon Infrared Dark Cloud: A Path for Massive Star Formation" *The Astrophysical Journal*, 912 :156, 2021.
- Kooi, Jason E.; Ascione, Madison L.; Reyes-Rosa, Lianis V.; Rier, Sophia K.; Ashas, Mohammad "VLA Measurements of Faraday Rotation Through a Coronal Mass Ejection Using Multiple Lines of Sight" *Solar Physics*, 296 :11, 2021.
- Kóspál, Á.; Cruz-Sáenz De Miera, F.; White, J. A.; Ábrahám, P.; Chen, L.; Csengeri, T.; Dong, R.; Dunham, M. M.; Fehér, O.; Green, J. D.; Hashimoto, J.; Henning, Th.; Hogerheijde, M.; Kudo, T.; Liu, H. B.; Takami, M.; Vorobyov, E. I. "Massive Compact Disks around FU Orionis-type Young Eruptive Stars Revealed by ALMA" *The Astrophysical Journal Supplement Series*, 256 :30, 2021.
- Koumpia, E.; De Wit, W.-J.; Oudmaijer, R. D.; Frost, A. J.; Lumsden, S.; Caratti O Garatti, A.; Goodwin, S. P.; Stecklum, B.; Mendigutía, I.; Ilee, J. D.; Vioque, M. "The first interferometric survey of massive YSOs in the K-band. Hot dust, ionised gas, and binarity at au scales" *Astronomy and Astrophysics*, 654 :A109, 2021.
- Kovačević, Anđjelka B.; Ilić, Dragana; Popović, Luka Č.; Radović, Viktor; Jankov, Isidora; Yoon, Ilsang; Caplar, Neven; Čvorović-Hajdinjak, Iva; Simić, Saša "On possible proxies of AGN light-curves cadence selection in future time domain surveys" *Monthly Notices of the Royal Astronomical Society*, 505 :5012, 2021.
- Kozieł-Wierzbowska, D.; Vale Asari, N.; Stasirska, G.; Herpich, F. R.; Sikora, M.; Żywucka, N.; Goyal, A. "Identifying Radio-active Galactic Nuclei among Radio-emitting Galaxies" *The Astrophysical Journal*, 910 :64, 2021.
- Kramer, M.; Stairs, I. H.; Krishnan, V. Venkatraman; Freire, P. C. C.; Abbate, F.; Bailes, M.; Burgay, M.; Buchner, S.; Champion, D. J.; Cognard, I.; Gautam, T.; Geiger, M.; Guillemot, L.; Hu, H.; Janssen, G.; Lower, M. E.; Parthasarathy, A.; Possenti, A.; Ransom, S.; Reardon, D. J.; Ridolfi, A.; Serylak, M.; Shannon, R. M.; Spiewak, R.; Theureau, G.; Van Straten, W.; Wex, N.; Oswald, L. S.; Posselt, B.; Sobey, C.; Barr, E. D.; Camilo, F.; Hugo, B.; Jameson, A.; Johnston, S.; Karastergiou, A.; Keith, M.; Ostrowski, S. "The Relativistic Binary Programme on MeerKAT: Science objectives and first results" *Monthly Notices of the Royal Astronomical Society*, 504 :2094, 2021.
- Kramer, M.; Stairs, I. H.; Manchester, R. N.; Wex, N.; Deller, A. T.; Coles, W. A.; Ali, M.; Burgay, M.; Camilo, F.; Cognard, I.; Damour, T.; Desvignes, G.; Ferdman, R. D.; Freire, P. C. C.; Grondin, S.; Guillemot, L.; Hobbs, G. B.; Janssen, G.; Karuppusamy, R.; Lorimer, D. R.; Lyne, A. G.; Mckee, J. W.; McLaughlin, M.; Münch, L. E.; Perera, B. B. P.; Pol, N.; Possenti, A.; Sarkissian, J.; Stappers, B. W.; Theureau, G. "Strong-Field Gravity Tests with the Double Pulsar" *Physical Review X*, 11 :41050, 2021.
- Krásná, Hana; Jaron, Frédéric; Gruber, Jakob; Böhm, Johannes; Nothnagel, Axel "Baseline-dependent clock offsets in VLBI data analysis" *Journal*

- of Geodesy, 95 :126, 2021.
- Krásná, Hana; Petrov, Leonid "The use of astronomy VLBA campaign MOJAVE for geodesy" *Journal of Geodesy*, 95 :101, 2021.
- Krieger, Nico; Walter, Fabian; Bolatto, Alberto D.; Guillard, Pierre; Lehnert, Matthew; Leroy, Adam K.; Pety, Jérôme; Emig, Kimberly L.; Levy, Rebecca C.; Krips, Melanie; Rix, Hans-Walter; Salak, Dragan; Weiss, Axel; Veilleux, Sylvain "NOEMA High-fidelity Imaging of the Molecular Gas in and around M82" *The Astrophysical Journal*, 915 :L3, 2021.
- Krishnakumar, M. A.; Manoharan, P. K.; Joshi, B. C.; Girgaonkar, R.; Desai, S.; Bagchi, M.; Nobleson, K.; Dey, L.; Susobhanan, A.; Susarla, S. C.; Surnis, M. P.; Maan, Y.; Gopakumar, A.; Basu, A.; Batra, N. D.; Choudhary, A.; De, K.; Gupta, Y.; Naidu, A. K.; Pathak, D.; Singha, J.; Prabu, T. "High precision measurements of interstellar dispersion measure with the upgraded GMRT" *Astronomy and Astrophysics*, 651 :A5, 2021.
- Kubo, Mariko; Umehata, Hideki; Matsuda, Yuichi; Kajisawa, Masaru; Steidel, Charles C.; Yamada, Toru; Tanaka, Ichi; Hatsukade, Bunyo; Tamura, Yoichi; Nakanishi, Kouichiro; Kohno, Kotaro; Lee, Kianhong; Matsuda, Keiichi "A Massive Quiescent Galaxy Confirmed in a Protocluster at  $z = 3.09$ " *The Astrophysical Journal*, 919 :6, 2021.
- Kumar, P.; Shannon, R. M.; Flynn, C.; Ostrowski, S.; Bhandari, S.; Day, C. K.; Deller, A. T.; Farah, W.; Kaczmarek, J. F.; Kerr, M.; Phillips, C.; Price, D. C.; Qiu, H.; Thyagarajan, N. "Extremely band-limited repetition from a fast radio burst source" *Monthly Notices of the Royal Astronomical Society*, 500 :2525, 2021.
- Kurahara, Kohei; Nakanishi, Hiroyuki; Kudoh, Yuki "Large-scale magnetic field structure of NGC 3627 based on a magnetic vector map" *Publications of the Astronomical Society of Japan*, 73 :220, 2021.
- Kuraszkiewicz, Joanna; Wilkes, Belinda J.; Atanas, Adam; Buchner, Johannes; McDowell, Jonathan C.; Willner, S. P.; Ashby, Matthew L. N.; Azadi, Mojegan; Barthel, Peter; Haas, Martin; Worrall, Diana M.; Birkinshaw, Mark; Antonucci, Robert; Chini, Rolf; Fazio, Giovanni G.; Lawrence, Charles; Ogle, Patrick "Beyond Simple AGN Unification with Chandra-observed 3CRR Sources at  $0.5 < z < 1$ " *The Astrophysical Journal*, 913 :134, 2021.
- Kurtovic, N. T.; Pinilla, P.; Long, F.; Benisty, M.; Manara, C. F.; Natta, A.; Pascucci, I.; Ricci, L.; Scholz, A.; Testi, L. "Size and structures of disks around very low mass stars in the Taurus star-forming region" *Astronomy and Astrophysics*, 645 :A139, 2021.
- Kuzmicz, Agnieszka; Jamroz, Marek "Giant Radio Quasars: Sample and Basic Properties" *The Astrophysical Journal Supplement Series*, 253 :25, 2021.
- La Plante, P.; Williams, P. K. G.; Kolopanis, M.; Dillon, J. S.; Beardsley, A. P.; Kern, N. S.; Wilensky, M.; Ali, Z. S.; Abdurashidova, Z.; Aguirre, J. E.; Alexander, P.; Balfour, Y.; Bernardi, G.; Billings, T. S.; Bowman, J. D.; Bradley, R. F.; Bull, P.; Burba, J.; Carey, S.; Carilli, C. L.; Cheng, C.; Deboer, D. R.; Dexter, M.; De Lera Acedo, E.; Ely, J.; Ewall-Wice, A.; Fagnoni, N.; Fritz, R.; Furlanetto, S. R.; Gale-Sides, K.; Glendenning, B.; Gorthi, D.; Greig, B.; Grobbelaar, J.; Halday, Z.; Hazelton, B. J.; Hewitt, J. N.; Hickish, J.; Jacobs, D. C.; Julius, A.; Kerrigan, J.; Kittiwisit, P.; Kohn, S. A.; Lanman, A.; Lekalake, T.; Lewis, D.; Liu, A.; Macmahon, D.; Malan, L.; Malgas, C.; Maree, M.; Martinot, Z. E.; Matsetela, E.; Mesinger, A.; Molewa, M.; Morales, M. F.; Mosiane, T.; Murray, S.; Neben, A. R.; Nikolic, B.; Parsons, A. R.; Pascua, R.; Patra, N.; Pieterse, S.; Pober, J. C.; Razavi-Ghods, N.; Ringuette, J.; Robnett, J.; Rosie, K.; Santos, M. G.; Sims, P.; Smith, C.; Syce, A.; Thyagarajan, N.; Zheng, H. "A Real Time Processing system for big data in astronomy: Applications to HERA" *Astronomy and Computing*, 36 :100489, 2021.
- Lacy, M.; Surace, J. A.; Farrah, D.; Nyland, K.; Afonso, J.; Brandt, W. N.; Clements, D. L.; Lagos, C. D. P.; Maraston, C.; Pforr, J.; Sajina, A.; Sako, M.; Vaccari, M.; Wilson, G.; Ballantyne, D. R.; Barkhouse, W. A.; Brunner, R.; Cane, R.; Clarke, T. E.; Cooper, M.; Cooray, A.; Covone, G.; D'Andrea, C.; Evrard, A. E.; Ferguson, H. C.; Frieman, J.; Gonzalez-Perez, V.; Gupta, R.; Hatziminaoglou, E.; Huang, J.; Jagannathan, P.; Jarvis, M. J.; Jones, K. M.; Kimball, A.; Lidman, C.; Lubin, L.; Marchetti, L.; Martini, P.; McMahon, R. G.; Mei, S.; Messias, H.; Murphy, E. J.; Newman, J. A.; Nichol, R.; Norris, R. P.; Oliver, S.; Perez-Fournon, I.; Peters, W. M.; Pierre, M.; Polisenky, E.; Richards, G. T.; Ridgway, S. E.; Röttgering, H. J. A.; Seymour, N.; Shirley, R.; Somerville, R.; Strauss, M. A.; Suntzeff, N.; Thorman, P. A.; Van Kampen, E.; Verma, A.; Wechsler, R.; Wood-Vasey, W. M. "A Spitzer survey of Deep Drilling Fields to be targeted by the Vera C. Rubin Observatory Legacy Survey of Space and Time" *Monthly Notices of the Royal Astronomical Society*, 501 :892, 2021.
- Lam, Ka Ho; Chen, Che-Yu; Li, Zhi-Yun; Yang, Haifeng; Cox, Erin G.; Looney, Leslie W.; Stephens, Ian "The transition of polarized dust thermal emission from the protostellar envelope to the disc scale" *Monthly Notices of the Royal Astronomical Society*, 507 :608, 2021.
- Lambert, S.; Liu, N.; Arias, E. F.; Barache, C.; Souchay, J.; Taris, F.; Liu, J. C.; Zhu, Z. "Parsec-scale alignments of radio-optical offsets with jets in AGNs from multifrequency geodetic VLBI, Gaia EDR3, and the MOJAVE program" *Astronomy and Astrophysics*, 651 :A64, 2021.
- Lamperti, I.; Harrison, C. M.; Mainieri, V.; Kakkad, D.; Perna, M.; Circosta, C.; Scholtz, J.; Carniani, S.; Ciccone, C.; Alexander, D. M.; Bischetti, M.; Calistro Rivera, G.; Chen, C.-C.; Cresci, G.; Feruglio, C.; Fiore, F.; Mannucci, F.; Marconi, A.; Martínez-Ramírez, L. N.; Netzer, H.; Piconcelli, E.; Puglisi, A.; Rosario, D. J.; Schramm, M.; Vietri, G.; Vignali, C.; Zappacosta, L. "SUPER. V. ALMA continuum observations of  $z \sim 2$  AGN and the elusive evidence of outflows influencing star formation" *Astronomy and Astrophysics*, 654 :A90, 2021.
- Langer, W. D.; Pineda, J. L.; Goldsmith, P. F.; Chambers, E. T.; Riquelme, D.; Anderson, L. D.; Luisi, M.; Justen, M.; Buchbender, C. "The dense warm ionized medium in the inner Galaxy" *Astronomy and Astrophysics*, 651 :A59, 2021.
- Laporte, N.; Meyer, R. A.; Ellis, R. S.; Robertson, B. E.; Chisholm, J.; Roberts-Borsani, G. W. "Probing cosmic dawn: Ages and star formation histories of candidate  $z \geq 9$  galaxies" *Monthly Notices of the Royal Astronomical Society*, 505 :3336, 2021.
- Laporte, N.; Zitrin, A.; Ellis, R. S.; Fujimoto, S.; Brammer, G.; Richard, J.; Oguri, M.; Caminha, G. B.; Kohno, K.; Yoshimura, Y.; Ao, Y.; Bauer, F. E.; Caputi, K.; Egami, E.; Espada, D.; González-López, J.; Hatsukade, B.; Knudsen, K. K.; Lee, M. M.; Magdis, G.; Ouchi, M.; Valentino, F.; Wang, T. "ALMA Lensing Cluster Survey: a strongly lensed multiply imaged dusty system at  $z \geq 6$ " *Monthly Notices of the Royal Astronomical Society*, 505 :4838, 2021.
- Law, Charles J.; Loomis, Ryan A.; Teague, Richard; Öberg, Karin I.; Czekala, Ian; Andrews, Sean M.; Huang, Jane; Aikawa, Yuri; Alarcón, Felipe; Bergin, Edwin A.; Bergner, Jennifer B.; Boehler, Yann; Booth, Alice S.; Bosman, Arthur D.; Calahan, Jenny K.; Cataldi, Gianni; Cleeves, L. Ilseadore; Furuya, Kenji; Guzmán, Viviana V.; Ilee, John D.; Le Gal, Romane; Liu, Yao; Long, Feng; Ménard, François; Nomura, Hideko; Qi, Chunhua; Schwarz, Kamber R.; Sierra, Anibal; Tsukagoshi, Takashi; Yamato, Yoshihide; Van'T Hoff, Merel L. R.; Walsh, Catherine; Wilner, David J.; Zhang, Ke "Molecules with ALMA at Planet-forming Scales (MAPS). III. Characteristics of Radial Chemical Substructures" *The Astrophysical Journal Supplement Series*, 257 :3, 2021.
- Law, Charles J.; Teague, Richard; Loomis, Ryan A.; Bae, Jaehan; Öberg, Karin I.; Czekala, Ian; Andrews, Sean M.; Aikawa, Yuri; Alarcón, Felipe; Bergin, Edwin A.; Bergner, Jennifer B.; Booth, Alice S.; Bosman, Arthur D.; Calahan, Jenny K.; Cataldi, Gianni; Cleeves, L. Ilseadore; Furuya, Kenji; Guzmán, Viviana V.; Huang, Jane; Ilee, John D.; Le Gal, Romane; Liu, Yao; Long, Feng; Ménard, François; Nomura, Hideko; Pérez, Laura M.; Qi, Chunhua; Schwarz, Kamber R.; Soto, Daniela; Tsukagoshi, Takashi; Yamato, Yoshihide; Van'T Hoff, Merel L. R.; Walsh, Catherine; Wilner, David J.; Zhang, Ke "Molecules with ALMA at Planet-forming Scales (MAPS). IV. Emission Surfaces and Vertical Distribution of Molecules" *The Astrophysical Journal Supplement Series*, 257 :4, 2021.
- Law, Charles J.; Zhang, Qizhou; Öberg, Karin I.; Galván-Madrid, Roberto; Keto, Eric; Liu, Hauyu Baobab; Ho, Paul T. P. "Subarcsecond Imaging of the Complex Organic Chemistry in Massive Star-forming Region G10-6

## APPENDIX A: PUBLICATIONS

- 0.4" The Astrophysical Journal, 909 :214, 2021.
- Le Gal, Romane; Öberg, Karin L.; Teague, Richard; Loomis, Ryan A.; Law, Charles J.; Walsh, Catherine; Bergin, Edwin A.; Ménard, François; Wilner, David J.; Andrews, Sean M.; Aikawa, Yuri; Booth, Alice S.; Cataldi, Gianni; Bergner, Jennifer B.; Bosman, Arthur D.; Cleeves, L. Ilse; Czekala, Ian; Furuya, Kenji; Guzmán, Viviana V.; Huang, Jane; Ilee, John D.; Nomura, Hideko; Qi, Chunhua; Schwarz, Kamber R.; Tsukagoshi, Takashi; Yamato, Yoshihide; Zhang, Ke "Molecules with ALMA at Planet-forming Scales (MAPS). XII. Inferring the C/O and S/H Ratios in Protoplanetary Disks with Sulfur Molecules" The Astrophysical Journal Supplement Series, 257 :12, 2021.
- Ledger, B.; Wilson, C. D.; Michiyama, T.; Iono, D.; Aalto, S.; Saito, T.; Bemis, A.; Aladro, R. "Observed CN and HCN intensity ratios exhibit subtle variations in extreme galaxy environments" Monthly Notices of the Royal Astronomical Society, 504 :5863, 2021.
- Lee, Chin-Fei; Li, Zhi-Yun; Yang, Haifeng; Daniel Lin, Zhe-Yu; Ching, Tao-Chung; Lai, Shih-Ping "What Produces Dust Polarization in the HH 212 Protostellar Disk at 878  $\mu\text{m}$ : Dust Self-scattering or Dichroic Extinction?" The Astrophysical Journal, 910 :75, 2021.
- Lee, Chin-Fei; Tabone, Benoit; Cabrit, Sylvie; Codella, Claudio; Podio, Linda; Ferreira, Jonathan; Jacquemin-Ide, Jonatan "First Detection of Interaction between a Magnetic Disk Wind and an Episodic Jet in a Protostellar System" The Astrophysical Journal, 907 :L41, 2021.
- Lee, Kin Long Kelvin; Changala, P. Bryan; Loomis, Ryan A.; Burkhardt, Andrew M.; Xue, Ci; Cordner, Martin A.; Charnley, Steven B.; Mccarthy, Michael C.; Mcguire, Brett A. "Interstellar Detection of 2-cyanocyclopentadiene, C<sub>5</sub>H<sub>5</sub>CN, a Second Five-membered Ring toward TMC-1" The Astrophysical Journal, 910 :L2, 2021.
- Lee, Kin Long Kelvin; Loomis, Ryan A.; Burkhardt, Andrew M.; Cooke, Ilsa R.; Xue, Ci; Siebert, Mark A.; Shingledecker, Christopher N.; Remijan, Anthony; Charnley, Steven B.; Mccarthy, Michael C.; Mcguire, Brett A. "Discovery of Interstellar trans-cyanovinylacetylene (HC<sub>3</sub>CCH = CHCN) and vinylcyanoacetylene (H<sub>2</sub>C = CHCN) in GOTHAM Observations of TMC-1" The Astrophysical Journal, 908 :L11, 2021.
- Lee, Kin Long Kelvin; Patterson, Jacqueline; Burkhardt, Andrew M.; Vankayalapati, Vivek; Mccarthy, Michael C.; Mcguire, Brett A. "Machine Learning of Interstellar Chemical Inventories" The Astrophysical Journal, 917 :L6, 2021.
- Lee, Minju M.; Nagao, Tohru; De Breuck, Carlos; Carniani, Stefano; Cresci, Giovanni; Hatsukade, Bunyo; Kawabe, Ryohei; Kohno, Kotaro; Maiolino, Roberto; Mannucci, Filippo; Marconi, Alessandro; Nakanishi, Kouichiro; Troncoso, Paulina; Umehata, Hideki "Dense and Warm Neutral Gas in BR 1202-0725 at  $z = 4.7$  as Traced by the [O I] 145  $\mu\text{m}$  Line" The Astrophysical Journal, 913 :41, 2021.
- Lee, Minju M.; Tanaka, Ichi; Iono, Daisuke; Kawabe, Ryohei; Kodama, Tadayuki; Kohno, Kotaro; Saito, Toshiaki; Tamura, Yoichi "Revisited Cold Gas Content with Atomic Carbon [C I] in  $z = 2.5$  Protocluster Galaxies" The Astrophysical Journal, 909 :181, 2021.
- Leemker, M.; Van'T Hoff, M. L. R.; Trapman, L.; Van Gelder, M. L.; Hogerheijde, M. R.; Ruiz-Rodríguez, D.; Van Dishoeck, E. F. "Chemically tracing the water snowline in protoplanetary disks with HCO<sup>+</sup>" Astronomy and Astrophysics, 646 :A3, 2021.
- Leisman, Lukas; Rhode, Katherine L.; Ball, Catherine; Pagel, Hannah J.; Cannon, John M.; Salzer, John J.; Janowiecki, Steven; Janesh, William F.; Józsa, Gyula I. G.; Giovanelli, Riccardo; Haynes, Martha P.; Adams, Elizabeth A. K.; Gray, Laurin; Smith, Nicholas J. "The ALFALFA Almost Dark Galaxy AGC 229101: A 2 Billion Solar Mass H I Cloud with a Very Low Surface Brightness Optical Counterpart" The Astronomical Journal, 162 :274, 2021.
- Lelli, Federico; Di Teodoro, Enrico M.; Fraternali, Filippo; Man, Allison W. S.; Zhang, Zhi-Yu; De Breuck, Carlos; Davis, Timothy A.; Maiolino, Roberto "A massive stellar bulge in a regularly rotating galaxy 1.2 billion years after the Big Bang" Science, 371 :713, 2021.
- Leroy, Adam K.; Hughes, Annie; Liu, Daizhong; Pety, Jérôme; Rosolowsky, Erik; Saito, Toshiaki; Schinnerer, Eva; Schrubba, Andreas; Usero, Antonio; Faesi, Christopher M.; Herrera, Cinthya N.; Chevance, Mélanie; Hygate, Alexander P. S.; Kepley, Amanda A.; Koch, Eric W.; Querejeta, Miguel; Sliwa, Kazimierz; Will, David; Wilson, Christine D.; Anand, Gagandeep S.; Barnes, Ashley; Belfiore, Francesco; Bešlić, Ivana; Bigiel, Frank; Blanc, Guillermo A.; Bolatto, Alberto D.; Boquien, Mèdéric; Cao, Yixian; Chandar, Rupali; Chastenet, Jérémy; Chiang, I. -Da; Congiu, Enrico; Dale, Daniel A.; Deger, Sinan; Den Brok, Jakob S.; Eibensteiner, Cosima; Emsellem, Eric; García-Rodríguez, Axel; Glover, Simon C. O.; Grasha, Kathryn; Groves, Brent; Henshaw, Jonathan D.; Jiménez Donaire, María J.; Kim, Jaeyeon; Klessen, Ralf S.; Kreckel, Kathryn; Kruijssen, J. M. Diederik; Larson, Kirsten L.; Lee, Janice C.; Mayker, Ness; Mcelroy, Rebecca; Meidt, Sharon E.; Mok, Angus; Pan, Hsi-An; Puschnig, Johannes; Razza, Alessandro; Sánchez-Blaázquez, Patricia; Sandstrom, Karin M.; Santoro, Francesco; Sardone, Amy; Scheuermann, Fabian; Sun, Jiayi; Thilker, David A.; Turner, Jordan A.; Ubeda, Leonardo; Utomo, Dyas; Watkins, Elizabeth J.; Williams, Thomas G. "PHANGS-ALMA Data Processing and Pipeline" The Astrophysical Journal Supplement Series, 255 :19, 2021.
- Leroy, Adam K.; Schinnerer, Eva; Hughes, Annie; Rosolowsky, Erik; Pety, Jérôme; Schrubba, Andreas; Usero, Antonio; Blanc, Guillermo A.; Chevance, Mélanie; Emsellem, Eric; Faesi, Christopher M.; Herrera, Cinthya N.; Liu, Daizhong; Meidt, Sharon E.; Querejeta, Miguel; Saito, Toshiaki; Sandstrom, Karin M.; Sun, Jiayi; Williams, Thomas G.; Anand, Gagandeep S.; Barnes, Ashley T.; Behrens, Erica A.; Belfiore, Francesco; Benincasa, Samantha M.; Bešlić, Ivana; Bigiel, Frank; Bolatto, Alberto D.; Den Brok, Jakob S.; Cao, Yixian; Chandar, Rupali; Chastenet, Jérémy; Chiang, I. -Da; Congiu, Enrico; Dale, Daniel A.; Deger, Sinan; Eibensteiner, Cosima; Egorov, Oleg V.; García-Rodríguez, Axel; Glover, Simon C. O.; Grasha, Kathryn; Henshaw, Jonathan D.; Ho, I. -Ting; Kepley, Amanda A.; Kim, Jaeyeon; Klessen, Ralf S.; Kreckel, Kathryn; Koch, Eric W.; Kruijssen, J. M. Diederik; Larson, Kirsten L.; Lee, Janice C.; Lopez, Laura A.; Machado, Josh; Mayker, Ness; Mcelroy, Rebecca; Murphy, Eric J.; Ostriker, Eve C.; Pan, Hsi-An; Pessa, Ismael; Puschnig, Johannes; Razza, Alessandro; Sánchez-Blázquez, Patricia; Santoro, Francesco; Sardone, Amy; Scheuermann, Fabian; Sliwa, Kazimierz; Sormani, Mattia C.; Stuber, Sophia K.; Thilker, David A.; Turner, Jordan A.; Utomo, Dyas; Watkins, Elizabeth J.; Whitmore, Bradley "PHANGS-ALMA: Arcsecond CO(2-1) Imaging of Nearby Star-forming Galaxies" The Astrophysical Journal Supplement Series, 257 :43, 2021.
- Leto, P.; Triggilio, C.; Krtićka, J.; Fossati, L.; Ignace, R.; Shultz, M. E.; Buemi, C. S.; Cerrigone, L.; Umana, G.; Ingallinera, A.; Bordiu, C.; Pillitteri, I.; Bufano, F.; Oskinova, L. M.; Agliozzo, C.; Cavallaro, F.; Riggi, S.; Loru, S.; Todt, H.; Giarrusso, M.; Phillips, N. M.; Robrade, J.; Leone, F. "A scaling relationship for non-thermal radio emission from ordered magnetospheres: from the top of the main sequence to planets" Monthly Notices of the Royal Astronomical Society, 507 :1979, 2021.
- Levy, Rebecca C.; Bolatto, Alberto D.; Leroy, Adam K.; Emig, Kimberly L.; Gorski, Mark; Krieger, Nico; Lenkić, Laura; Meier, David S.; Mills, Elisabeth A. C.; Ott, Jürgen; Rosolowsky, Erik; Tarantino, Elizabeth; Veilleux, Sylvain; Walter, Fabian; Weiß, Axel; Zwaan, Martin A. "Outflows from Super Star Clusters in the Central Starburst of NGC253" The Astrophysical Journal, 912 :4, 2021.
- Li, Jianrui; Emonts, Bjorn H. C.; Cai, Zheng; Prochaska, J. Xavier; Yoon, Ilsang; Lehnert, Matthew D.; Zhang, Shiwu; Wu, Yunjing; Li, Jianan; Li, Mingyu; Lacy, Mark; Villar-Martín, Montserrat "Massive Molecular Outflow and 100 kpc Extended Cold Halo Gas in the Enormous Ly $\alpha$  Nebula of QSO 1228+3128" The Astrophysical Journal, 922 :L29, 2021.
- Li, Juan; Wang, Junzhi; Lu, Xing; Ilyushin, Vadim; Motiyenko, Roman A.; Gou, Qian; Alekseev, Eugene A.; Quan, Donghui; Margulès, Laurent; Gao, Feng; Lovas, Frank J.; Wu, Yajun; Bergin, Edwin; Li, Shanghuo; Shen, Zhiqiang; Du, Fujun; Li, Meng; Zheng, Siqi; Zheng, Xingwu "Propionamide (C<sub>2</sub>H<sub>5</sub>CONH<sub>2</sub>): The Largest Peptide-like Molecule in Space" The Astrophysical Journal, 919 :4, 2021.



- Li, Qiong; Wang, Ran; Dannerbauer, Helmut; Cai, Zheng; Emonts, Bjorn; Prochaska, Jason Xavier; Battaia, Fabrizio Arrigoni; Neri, Roberto; Zhang, Chengpeng; Fan, Xiaohui; Jin, Shuowen; Yoon, Ilsang; Bechtel, Shane "Discovery of a Protocluster Core Associated with an Enormous Ly $\alpha$  Nebula at  $z = 2.3$ " *The Astrophysical Journal*, 922 :236, 2021.
- Li, Shanghuo; Lu, Xing; Zhang, Qizhou; Lee, Chang Won; Sanhueza, Patricio; Beuther, Henrik; Jiménez-Serra, Izaskun.; Qiu, Keping; Palau, Aina; Feng, Siyi; Pillai, Thushara; Kim, Kee-Tae; Liu, Hong-Li; Girart, Josep Miquel.; Liu, Tie; Wang, Junzhi; Wang, Ke; Liu, Haoyu Baobab; Smith, Howard A.; Li, Di; Lee, Jeong-Eun; Li, Fei; Li, Juan; Kim, Shinyoung; Yue, Nannan; Strom, Shaye "A Low-mass Cold and Quiescent Core Population in a Massive Star Protocluster" *The Astrophysical Journal*, 912 :L7, 2021.
- Liao, Wei-Ting; Chen, Yu-Ching; Liu, Xin; Holgado, A. Miguel; Guo, Hengxiao; Gruendl, Robert; Morganson, Eric; Shen, Yue; Davis, Tamara; Kessler, Richard; Martini, Paul; McMahon, Richard G.; Allam, Sahar; Annis, James; Avila, Santiago; Banerji, Manda; Bechtol, Keith; Bertin, Emmanuel; Brooks, David; Buckley-Geer, Elizabeth; Carnero Rosell, Aurelio; Carrasco Kind, Matias; Carretero, Jorge; Javier Castander, Francisco; Cunha, Carlos; D'Andrea, Chris; Da Costa, Luiz; Davis, Christopher; De Vicente, Juan; Desai, Shantanu; Thomas Diehl, H.; Doel, Peter; Eifler, Tim; Evrard, August; Flaugh, Brenna; Fosalba, Pablo; Frieman, Josh; Garcia-Bellido, Juan; Gaztanaga, Enrique; Glazebrook, Karl; Gruen, Daniel; Gschwend, Julia; Gutierrez, Gaston; Hartley, Will; Hollowood, Devon L.; Honscheid, Klaus; Hoyle, Ben; James, David; Krause, Elisabeth; Kuehn, Kyle; Lima, Marcos; Maia, Marcio; Marshall, Jennifer; Menanteau, Felipe; Miquel, Ramon; Plazas Malagón, Andrés; Roodman, Aaron; Sanchez, Eusebio; Scarpine, Vic; Schubnell, Michael; Serrano, Santiago; Smith, Mathew; Smith, R. Chris; Soares-Santos, Marcelle; Sobreira, Flavia; Suchyta, Eric; Swanson, Molly; Tarle, Gregory; Vikram, Vinu; Walker, Alistair "Discovery of a candidate binary supermassive black hole in a periodic quasar from circumbinary accretion variability" *Monthly Notices of the Royal Astronomical Society*, 500 :4025, 2021.
- Ligterink, N. F. W.; Ahmadi, A.; Coutens, A.; Tychoniec, Ł.; Calcutt, H.; Van Dishoeck, E. F.; Linnartz, H.; Jørgensen, J. K.; Garrod, R. T.; Bouwman, J. "The prebiotic molecular inventory of Serpens SMM1. I. An investigation of the isomers CH<sub>3</sub>NCO and HOCH<sub>2</sub>CN" *Astronomy and Astrophysics*, 647 :A87, 2021.
- Lin, Fang Xi; Lin, Hsiu-Hsien; Luo, Jing; Main, Robert; Mckee, James; Pen, Ue-Li; Simard, Dana; Van Kerkwijk, Marten H. "Profile changes associated with dispersion measure events in PSR J1713+0747" *Monthly Notices of the Royal Astronomical Society*, 508 :1115, 2021.
- Lin, Zhe-Yu Daniel; Lee, Chin-Fei; Li, Zhi-Yun; Tobin, John J.; Turner, Neal J. "Inferring (Sub)millimeter Dust Opacities and Temperature Structure in Edge-on Protostellar Disks From Resolved Multi-Wavelength Continuum Observations: The Case of the HH 212 Disk" *Monthly Notices of the Royal Astronomical Society*, 501 :1316, 2021.
- Linden, S. T.; Evans, A. S.; Larson, K.; Privon, G. C.; Armus, L.; Rich, J.; Diaz-Santos, T.; Murphy, E. J.; Song, Y.; Barcos-Muñoz, L.; Howell, J.; Charmandaris, V.; Inami, H.; U, V.; Surace, J. A.; Mazzarella, J. M.; Calzetti, D. "Massive Star Cluster Formation and Destruction in Luminous Infrared Galaxies in GOALS. II. An ACS/WFC3 Survey of Nearby LIRGs" *The Astrophysical Journal*, 923 :278, 2021.
- Linhoff, Lena; Sandrock, Alexander; Kadler, Matthias; Elsässer, Dominik; Rhode, Wolfgang "Excluding possible sites of high-energy emission in 3C 84" *Monthly Notices of the Royal Astronomical Society*, 500 :4671, 2021.
- Lioudakis, I.; Hovatta, T.; Aller, M. F.; Aller, H. D.; Gurwell, M. A.; Lähteenmäki, A.; Tornikoski, M. "Identifying changing jets through their radio variability" *Astronomy and Astrophysics*, 654 :A169, 2021.
- Lisakov, M. M.; Kravchenko, E. V.; Pushkarev, A. B.; Kovalev, Y. Y.; Savolainen, T. K.; Lister, M. L. "An Oversized Magnetic Sheath Wrapping around the Parsec-scale Jet in 3C 273" *The Astrophysical Journal*, 910 :35, 2021.
- Lister, M. L.; Homan, D. C.; Kellermann, K. I.; Kovalev, Y. Y.; Pushkarev, A. B.; Ros, E.; Savolainen, T. "Monitoring Of Jets in Active Galactic Nuclei with VLBA Experiments. XVIII. Kinematics and Inner Jet Evolution of Bright Radio-loud Active Galaxies" *The Astrophysical Journal*, 923 :30, 2021.
- Liszt, Harvey "Reconciling X-Ray and  $\lambda$ 21 cm H I Absorption Gas Column Densities toward Obscured AGN" *The Astrophysical Journal*, 908 :127, 2021.
- Litvinov, D. A.; Nunes, N. V.; Filetkin, A. I.; Bartel, N.; Gurvits, L. I.; Molera Calves, G.; Rudenko, V. N.; Zakhvatkin, M. V. "The antenna phase center motion effect in high-accuracy spacecraft tracking experiments" *Advances in Space Research*, 68 :4274, 2021.
- Liu, Daizhong; Daddi, Emanuele; Schinnerer, Eva; Saito, Toshiki; Leroy, Adam; Silverman, John D.; Valentino, Francesco; Magdis, Georgios E.; Gao, Yu; Jin, Shuowen; Puglisi, Annagrazia; Groves, Brent "CO Excitation, Molecular Gas Density, and Interstellar Radiation Field in Local and High-redshift Galaxies" *The Astrophysical Journal*, 909 :56, 2021.
- Liu, Haoyu Baobab "Magnetically Regulated Disk Formation in the Inner 100 au Region of the Class 0 Young Stellar Object OMC-3/MMS 6 Resolved by JVLBA and ALMA" *The Astrophysical Journal*, 914 :25, 2021.
- Liu, Haoyu Baobab; Tsai, An-Li; Chen, Wen Ping; Liu, Jin Zhong; Zhang, Xuan; Ma, Shuo; Elbakyan, Vardan; Green, Joel D.; Hales, Antonio S.; Liu, Sheng-Yuan; Takami, Michihiro; Pérez, Sebastián; Vorobyov, Eduard I.; Yang, Yao-Lun "Millimeter-sized Dust Grains Surviving the Water-sublimating Temperature in the Inner 10 au of the FU Ori Disk" *The Astrophysical Journal*, 923 :270, 2021.
- Liu, Hong-Li; Liu, Tie; Evans, Neal J., II; Wang, Ke; Garay, Guido; Qin, Sheng-Li; Li, Shanghuo; Stutz, Amelia; Goldsmith, Paul F.; Liu, Sheng-Yuan; Tej, Anandmayee; Zhang, Qizhou; Juvela, Mika; Li, Di; Wang, Jun-Zhi; Bronfman, Leonardo; Ren, Zhiyuan; Wu, Yue-Fang; Kim, Kee-Tae; Lee, Chang Won; Tatematsu, Ken'ichi; Cunningham, Maria R.; Liu, Xun-Chuan; Wu, Jing-Wen; Hirota, Tomoya; Lee, Jeong-Eun; Li, Pak-Shing; Kang, Sung-Ju; Mardones, Diego; Ristorcelli, Isabelle; Zhang, Yong; Luo, Qiu-Yi; Toth, L. Viktor; Yi, Hee-Weon; Yun, Hyeon-Sik; Peng, Ya-Ping; Li, Juan; Zhu, Feng-Yao; Shen, Zhi-Qiang; Baug, Tapas; Dewangan, L. K.; Chakali, Eswaraiah; Liu, Rong; Xu, Feng-Wei; Wang, Yu; Zhang, Chao; Li, Jinzeng; Zhang, Chao; Zhou, Jianwen; Tang, Mengyao; Xue, Qiaowei; Issac, Namitha; Soam, Archana; Álvarez-Gutiérrez, Rodrigo H. "ATOMS: ALMA three-millimeter observations of massive star-forming regions - III. Catalogues of candidate hot molecular cores and hyper/ultra compact H II regions" *Monthly Notices of the Royal Astronomical Society*, 505 :2801, 2021.
- Liu, Kuo; Desvignes, Gregory; Eatough, Ralph P.; Karuppusamy, Ramesh; Kramer, Michael; Torne, Pablo; Wharton, Robert; Chatterjee, Shami; Cordes, James M.; Crew, Geoffrey B.; Goddi, Ciriaco; Ransom, Scott M.; Rottmann, Helge; Abbate, Federico; Bower, Geoffrey C.; Brinkerink, Christiaan D.; Falcke, Heino; Noutsos, Aristeidis; Hernández-Gómez, Antonio; Jiang, Wu; Johnson, Michael D.; Lu, Ru-Sen; Pidopryhora, Yurii; Rezzolla, Luciano; Shao, Lijing; Shen, Zhiqiang; Wex, Norbert "An 86 GHz Search for Pulsars in the Galactic Center with the Atacama Large Millimeter / submillimeter Array" *The Astrophysical Journal*, 914 :30, 2021.
- Liu, Lijie; Bureau, Martin; Blitz, Leo; Davis, Timothy A.; Onishi, Kyoko; Smith, Mark; North, Eve; Iguchi, Satoru "WISDOM Project - IX. Giant molecular clouds in the lenticular galaxy NGC 4429: effects of shear and tidal forces on clouds" *Monthly Notices of the Royal Astronomical Society*, 505 :4048, 2021.
- Liu, Mengyao; Tan, Jonathan C.; Marvil, Joshua; Kong, Shuo; Rosero, Viviana; Caselli, Paola; Cosentino, Giuliana "SiO Outflows as Tracers of Massive Star Formation in Infrared Dark Clouds" *The Astrophysical Journal*, 921 :96, 2021.
- Liu, Yuanqi; Wang, Ran; Momjian, Emmanuel; Bañados, Eduardo; Zeimann, Greg; Willott, Chris J.; Matsuoka, Yoshiki; Omont, Alain; Shao, Yali; Li, Qiong; Li, Jianan "Constraining the Quasar Radio-loud Fraction at  $z$

## APPENDIX A: PUBLICATIONS

- 6 with Deep Radio Observations" *The Astrophysical Journal*, 908 :124, 2021.
- Lo, Wen-Ping; Asada, Keiichi; Matsushita, Satoki; Nakamura, Masanori; Pu, Hung-Yi; Tseng, Chihyin; Akiyama, Kazunori; Algaba, Juan Carlos; Bower, Geoffrey C.; Rao, Ramprasad; Koay, Jun Yi; Koch, Patrick M.; Koyama, Shoko; Ho, Paul T. P.; Inoue, Makoto "Constraints on the Mass Accretion Rate onto the Supermassive Black Hole of Cygnus A Using the Submillimeter Array" *The Astrophysical Journal*, 911 :35, 2021.
- Loiacono, Federica; Decarli, Roberto; Gruppioni, Carlotta; Talia, Margherita; Cimatti, Andrea; Zamorani, Gianni; Pozzi, Francesca; Yan, Lin; Lemaux, Brian C.; Riechers, Dominik A.; Le Fèvre, Olivier; Bèthermin, Matthieu; Capak, Peter; Cassata, Paolo; Faisst, Andreas; Schaerer, Daniel; Silverman, John D.; Bardelli, Sandro; Boquien, Médéric; Burkutean, Sandra; Dessauges-Zavadsky, Miroslava; Fudamoto, Yoshinobu; Fujimoto, Seiji; Ginolfi, Michele; Hathi, Nimish P.; Jones, Gareth C.; Khusanova, Yana; Koekemoer, Anton M.; Lagache, Guilaine; Lubin, Lori M.; Massardi, Marcella; Oesch, Pascal; Romano, Michael; Vallini, Livia; Vergani, Daniela; Zucca, Elena "The ALPINE-ALMA [C II] survey. Luminosity function of serendipitous [C II] line emitters at  $z \sim 5$ " *Astronomy and Astrophysics*, 646 :A76, 2021.
- Long, Feng; Andrews, Sean M.; Vega, Justin; Wilner, David J.; Chandler, Claire J.; Ragusa, Enrico; Teague, Richard; Pérez, Laura M.; Calvet, Nuria; Carpenter, John M.; Henning, Thomas; Kwon, Woojin; Linz, Hendrik; Ricci, Luca "The Architecture of the V892 Tau System: The Binary and Its Circumbinary Disk" *The Astrophysical Journal*, 915 :131, 2021.
- Long, Feng; Bosman, Arthur D.; Cazzoletti, Paolo; Van Dishoeck, Erwine F.; Öberg, Karin I.; Facchini, Stefano; Tazzari, Marco; Guzmán, Viviana V.; Testi, Leonardo "Exploring HNC and HCN line emission as probes of the protoplanetary disk temperature" *Astronomy and Astrophysics*, 647 :A118, 2021.
- Loomis, Ryan A.; Burkhardt, Andrew M.; Shingledecker, Christopher N.; Charnley, Steven B.; Cordiner, Martin A.; Herbst, Eric; Kalenskii, Sergei; Lee, Kin Long Kelvin; Willis, Eric R.; Xue, Ci; Remijan, Anthony J.; Mccarthy, Michael C.; Mcguire, Brett A. "An investigation of spectral line stacking techniques and application to the detection of HC11N" *Nature Astronomy*, 5 :188, 2021.
- Lopez-Rodriguez, Enrique "The magnetic field across the molecular warped disk of Centaurus A" *Nature Astronomy*, 5 :604, 2021.
- Lopez-Rodriguez, Enrique; Beck, Rainer; Clark, Susan E.; Hughes, Annie; Borlaff, Alejandro S.; Ntormousi, Evangelia; Grosset, Lucas; Tassis, Konstantinos; Beckman, John E.; Subramanian, Kandaswamy; Dale, Daniel; Díaz-Santos, Tanio "Extragalactic Magnetism with SOFIA (Legacy Program) - II: A Magnetically Driven Flow in the Starburst Ring of NGC 1097" *The Astrophysical Journal*, 923 :150, 2021.
- Lovell, J. B.; Marino, S.; Wyatt, M. C.; Kennedy, G. M.; Macgregor, M. A.; Stapelfeldt, K.; Dent, B.; Krist, J.; Matrà, L.; Kral, Q.; Panić, O.; Pearce, T. D.; Wilner, D. "High-resolution ALMA and HST images of q1 Eri: an asymmetric debris disc with an eccentric Jupiter" *Monthly Notices of the Royal Astronomical Society*, 506 :1978, 2021.
- Lovell, J. B.; Wyatt, M. C.; Ansdell, M.; Kama, M.; Kennedy, G. M.; Manara, C. F.; Marino, S.; Matrà, L.; Rosotti, G.; Tazzari, M.; Testi, L.; Williams, J. P. "ALMA Survey of Lupus Class III Stars: Early Planetary Belt Formation and Rapid Disk Dispersal" *Monthly Notices of the Royal Astronomical Society*, 500 :4878, 2021.
- Lu, Wenbin; Mckee, Christopher F.; Mooley, Kunal P. "Infrared dust echoes from neutron star mergers" *Monthly Notices of the Royal Astronomical Society*, 507 :3672, 2021.
- Lu, Xing; Li, Shanghuo; Ginsburg, Adam; Longmore, Steven N.; Kruijssen, J. M. Diederik; Walker, Daniel L.; Feng, Siyi; Zhang, Qizhou; Battersby, Cara; Pillai, Thushara; Mills, Elisabeth A. C.; Kauffmann, Jens; Cheng, Yu; Inutsuka, Shu-Ichiro "ALMA Observations of Massive Clouds in the Central Molecular Zone: Ubiquitous Protostellar Outflows" *The Astrophysical Journal*, 909 :177, 2021.
- Luo, Jing; Ransom, Scott; Demorest, Paul; Ray, Paul S.; Archibald, Anne; Kerr, Matthew; Jennings, Ross J.; Bachetti, Matteo; Van Haasteren, Rutger; Champagne, Chloe A.; Colen, Jonathan; Phillips, Camryn; Zimmerman, Josef; Stovall, Kevin; Lam, Michael T.; Jenet, Fredrick A. "PINT: A Modern Software Package for Pulsar Timing" *The Astrophysical Journal*, 911 :45, 2021.
- Luo, Yingjie; Chen, Bin; Yu, Sijie; Bastian, T. S.; Krucker, Säm "Radio Spectral Imaging of an M8.4 Eruptive Solar Flare: Possible Evidence of a Termination Shock" *The Astrophysical Journal*, 911 :4, 2021.
- Lynch, C. R.; Galvin, T. J.; Line, J. L. B.; Jordan, C. H.; Trott, C. M.; Chege, J. K.; Mckinley, B.; Johnston-Hollitt, M.; Tingay, S. J. "The MWA long baseline Epoch of reionisation survey—I. Improved source catalogue for the EoR 0 field" *Publications of the Astronomical Society of Australia*, 38 :e057, 2021.
- Lyo, A. -Ran; Kim, Jongsoo; Sadavoy, Sarah; Johnstone, Doug; Berry, David; Pattle, Kate; Kwon, Woojin; Bastien, Pierre; Onaka, Takashi; Di Francesco, James; Kang, Ji-Hyun; Furuya, Ray; Hull, Charles L. H.; Tamura, Motohide; Koch, Patrick M.; Ward-Thompson, Derek; Hasegawa, Tetsuo; Hoang, Thiem; Arzoumanian, Doris; Won Lee, Chang; Lee, Chin-Fei; Byun, Do-Young; Kirchschlager, Florian; Doi, Yasuo; Kim, Kee-Tae; Hwang, Jihye; Diep, Pham Ngoc; Fanciullo, Lapo; Lee, Sang-Sung; Park, Geumsook; Yoo, Hyunju; Chung, Eun Jung; Whitworth, Anthony; Mairs, Steve; Soam, Archana; Liu, Tie; Tang, Xindi; Coudé, Simon; André, Philippe; Bourke, Tyler L.; Vivien Chen, Hwei-Ru; Chen, Zhiwei; Ping Chen, Wen; Chen, Mike; Ching, Tao-Chung; Cho, Jungyeon; Choi, Minho; Choi, Yunhee; Chrysostomou, Antonio; Dai, Sophia; Dowell, C. Darren; Duan, Hao-Yuan; Duan, Yan; Eden, David; Eswarajah, Chakali; Eyres, Stewart; Fiege, Jason; Fissel, Laura M.; Franzmann, Erica; Friberg, Per; Friesen, Rachel; Fuller, Gary; Gledhill, Tim; Graves, Sarah; Greaves, Jane; Griffin, Matt; Gu, Qilao; Han, Ilseung; Hatchell, Jannifer; Hayashi, Saeko; Houde, Martin; Inoue, Tsuyoshi; Inutsuka, Shu-Ichiro; Iwasaki, Kazunari; Jeong, Il-Gyo; Kang, Miju; Kataoka, Akimasa; Kawabata, Koji; Kemper, Francisca; Kim, Gwanjeong; Kim, Mi-Ryang; Kim, Shinyoung; Kim, Kyoung Hee; Kirk, Jason; Kobayashi, Masato I. N.; Könyves, Vera; Kusune, Takayoshi; Kwon, Jungmi; Lacaille, Kevin; Lai, Shih-Ping; Law, Chi-Yan; Lee, Jeong-Eun; Lee, Yong-Hee; Lee, Hyesung; Li, Dalei; Li, Di; Li, Hua-Bai; Liu, Hong-Li; Liu, Junhao; Liu, Sheng-Yuan; Lu, Xing; Matsumura, Masafumi; Matthews, Brenda; Moriarty-Schieven, Gerald; Nagata, Tetsuya; Nakamura, Fumitaka; Nakanishi, Hiroyuki; Bich Ngoc, Nguyen; Ohashi, Nagayoshi; Parsons, Harriet; Peretto, Nicolas; Priestley, Felix; Pyo, Tae-Soo; Qian, Lei; Qiu, Keping; Rao, Ramprasad; Rawlings, Jonathan; Rawlings, Mark G.; Retter, Brendan; Richer, John; Rigby, Andrew; Saito, Hiro; Savini, Giorgio; Scaife, Anna; Seta, Masumichi; Shimajiri, Yoshito; Shinnaga, Hiroko; Tahani, Mehrnoosh; Tang, Ya-Wen; Tomisaka, Kohji; Tram, Le Ngoc; Tsukamoto, Yusuke; Viti, Serena; Wang, Jia-Wei; Wang, Hongchi; Xie, Jinjin; Yen, Hsi-Wei; Yuan, Jinghua; Yun, Hyeong-Sik; Zenko, Tetsuya; Zhang, Guoyin; Zhang, Chuan-Peng; Zhang, Yapeng; Zhou, Jianjun; Zhu, Lei; De Looze, Ilse; Dowell, C. Darren; Falle, Sam; Robitaille, Jean-François; Van Loo, Sven "The JCMT BISTRO Survey: An 850/450  $\mu\text{m}$  Polarization Study of NGC 2071IR in Orion B" *The Astrophysical Journal*, 918 :85, 2021.
- Lyu, Bing; Yan, Zhen; Yu, Wenfei; Wu, Qingwen "Long-term and multiwavelength evolution of a changing-look AGN Mrk 1018" *Monthly Notices of the Royal Astronomical Society*, 506 :4188, 2021.
- Lyu, Fen; Meng, Yan-Zhi; Tang, Zhen-Fan; Li, Ye; Wei, Jun-Jie; Geng, Jin-Jun; Lin, Lin; Deng, Can-Min; Wu, Xue-Feng "A comparison between repeating bursts of FRB 121102 and giant pulses from Crab pulsar and its applications" *Frontiers of Physics*, 16 :24503, 2021.
- Maccagni, F. M.; Serra, P.; Gaspari, M.; Kleiner, D.; Morokuma-Matsui, K.; Oosterloo, T. A.; Onodera, M.; Kamphuis, P.; Loi, F.; Thorat, K.; Ramatsoku, M.; Smirnov, O.; White, S. V. "AGN feeding and feedback in Fornax A. Kinematical analysis of the multi-phase ISM" *Astronomy and Astrophysics*, 656 :A45, 2021.

- Macgregor, Meredith A.; Weinberger, Alycia J.; Loyd, R. O. Parke; Shkolnik, Evgenya; Barclay, Thomas; Howard, Ward S.; Zic, Andrew; Osten, Rachel A.; Cranmer, Steven R.; Kowalski, Adam F.; Lenc, Emil; Youngblood, Allison; Estes, Anna; Wilner, David J.; Forbrich, Jan; Hughes, Anna; Law, Nicholas M.; Murphy, Tara; Boley, Aaron; Matthews, Jaymie "Discovery of an Extremely Short Duration Flare from Proxima Centauri Using Millimeter through Far-ultraviolet Observations" *The Astrophysical Journal*, 911 :L25, 2021.
- Macías, E.; Guerra-Alvarado, O.; Carrasco-González, C.; Ribas, Á.; Espaillat, C. C.; Huang, J.; Andrews, S. M. "Characterizing the dust content of disk substructures in TW Hydrae" *Astronomy and Astrophysics*, 648 :A33, 2021.
- Maddox, N.; Frank, B. S.; Ponomareva, A. A.; Jarvis, M. J.; Adams, E. A. K.; Davé, R.; Oosterloo, T. A.; Santos, M. G.; Blyth, S. L.; Glowacki, M.; Kraan-Korteweg, R. C.; Mulaudzi, W.; Namumba, B.; Prandoni, I.; Rajohnson, S. H. A.; Spekkens, K.; Adams, N. J.; Bowler, R. A. A.; Collier, J. D.; Heywood, I.; Sekhar, S.; Taylor, A. R. "MIGHTEE-HI: The H I emission project of the MeerKAT MIGHTEE survey" *Astronomy and Astrophysics*, 646 :A35, 2021.
- Madrid, Juan P. "AGN Jets and a Fanciful Trio of Black Holes in the Abell 85 Brightest Cluster Galaxy" *Publications of the Astronomical Society of the Pacific*, 133 :14101, 2021.
- Maeda, Fumiya; Ohta, Kouji; Fujimoto, Yusuke; Habe, Asao "Connection among environment, cloud-cloud collision speed, and star formation activity in the strongly barred galaxy NGC 1300" *Monthly Notices of the Royal Astronomical Society*, 502 :2238, 2021.
- Maeda, Keiichi; Chandra, Poonam; Matsuoka, Tomoki; Ryder, Stuart; Moriya, Takashi J.; Kuncarayakti, Hanindy; Lee, Shiu-Hang; Kundu, Esha; Patnaude, Daniel; Saito, Tomoki; Folatelli, Gaston "The Final Months of Massive Star Evolution from the Circumstellar Environment around SN Ic 2020oi" *The Astrophysical Journal*, 918 :34, 2021.
- Magic Collaboration; Acciari, V. A.; Ansoldi, S.; Antonelli, L. A.; Arbet Engels, A.; Artero, M.; Asano, K.; Baack, D.; Babić, A.; Baquero, A.; Barres De Almeida, U.; Barrio, J. A.; Becerra González, J.; Bednarek, W.; Bellizzi, L.; Bernardini, E.; Bernardos, M.; Berti, A.; Besenrieder, J.; Bhattacharyya, W.; Bigongiari, C.; Biland, A.; Blanch, O.; Bonnoli, G.; Bošnjak, Ž.; Busetto, G.; Carosi, R.; Ceribella, G.; Cerruti, M.; Chai, Y.; Chilingarian, A.; Cikota, S.; Colak, S. M.; Colombo, E.; Contreras, J. L.; Cortina, J.; Covino, S.; D'Amico, G.; D'Elia, V.; Da Vela, P.; Dazzi, F.; De Angelis, A.; De Lotto, B.; Delfino, M.; Delgado, J.; Delgado Mendez, C.; Depaoli, D.; Di Piero, F.; Di Venere, L.; Do Souto Espiñeira, E.; Dominis Prester, D.; Donini, A.; Dorner, D.; Doró, M.; Elsaesser, D.; Fallah Ramazani, V.; Fattorini, A.; Ferrara, G.; Foffano, L.; Fonseca, M. V.; Font, L.; Fruck, C.; Fukami, S.; García López, R. J.; Garczarczyk, M.; Gasparyan, S.; Gaug, M.; Giglietto, N.; Giordano, F.; Gliwiny, P.; Godinović, N.; Green, J. G.; Green, D.; Hadasch, D.; Hahn, A.; Heckmann, L.; Herrera, J.; Hoang, J.; Hrupec, D.; Hütten, M.; Inada, T.; Inoue, S.; Ishio, K.; Iwamura, Y.; Jormanainen, J.; Jouvin, L.; Kajiwara, Y.; Karjalainen, M.; Kerszberg, D.; Kobayashi, Y.; Kubo, H.; Kushida, J.; Lamastra, A.; Lelas, D.; Leone, F.; Lindfors, E.; Lombardi, S.; Longo, F.; López-Coto, R.; López-Moya, M.; López-Oramas, A.; Loporchio, S.; Machado De Oliveira Fraga, B.; Maggio, C.; Majumdar, P.; Makariev, M.; Mallamaci, M.; Maneva, G.; Manganaro, M.; Mannheim, K.; Maraschi, L.; Mariotti, M.; Martínez, M.; Mazin, D.; Mender, S.; Mićanović, S.; Miceli, D.; Miener, T.; Minev, M.; Miranda, J. M.; Mirzoyan, R.; Molina, E.; Moralejo, A.; Morcuende, D.; Moreno, V.; Moretti, E.; Neustroev, V.; Nigro, C.; Nilsson, K.; Ninci, D.; Nishijima, K.; Noda, K.; Nozaki, S.; Ohtani, Y.; Oka, T.; Otero-Santos, J.; Paiano, S.; Palatiello, M.; Paneque, D.; Paoletti, R.; Paredes, J. M.; Pavletić, L.; Peñil, P.; Perennes, C.; Persic, M.; Prada Moroni, P. G.; Prandini, E.; Priyadarshi, C.; Puljak, I.; Rhode, W.; Ribó, M.; Rico, J.; Righi, C.; Rugliancich, A.; Saha, L.; Sahakyan, N.; Saito, T.; Sakurai, S.; Satalecka, K.; Saturni, F. G.; Schleicher, B.; Schmidt, K.; Schweizer, J.; Sitarek, J.; Šnidarić, I.; Sobczynska, D.; Spolon, A.; Stamerra, A.; Strom, D.; Strzys, M.; Suda, Y.; Suric, T.; Takahashi, M.; Tavecchio, F.; Temnikov, P.; Terzić, T.; Teshima, M.; Torres-Albà, N.; Tosti, L.; Truzzi, S.; Tutone, A.; Van Scherpenberg, J.; Vanzo, G.; Vazquez Acosta, M.; Ventura, S.; Verguilo, V.; Vigorito, C. F.; Vitale, V.; Vovk, I.; Will, M.; Zarić, D.; Angioni, R.; D'Ammando, F.; Ciprini, S.; Cheung, C. C.; Orienti, M.; Pacciani, L.; Prajapati, P.; Kumar, P.; Ganesh, S.; Minev, M.; Kurtenkov, A.; Marchini, A.; Carrasco, L.; Escobedo, G.; Porras, A.; Recillas, E.; Lähteenmäki, A.; Tornikoski, M.; Berton, M.; Tammi, J.; Vera, R. J. C.; Jorstad, S. G.; Marscher, A. P.; Weaver, Z. R.; Hart, M.; Hallum, M. K.; Larionov, V. M.; Borman, G. A.; Grishina, T. S.; Kopatskaya, E. N.; Larionova, E. G.; Nikiforova, A. A.; Morozova, D. A.; Savchenko, S. S.; Troitskaya, Yu. V.; Troitsky, I. S.; Vasilyev, A. A.; Hodges, M.; Hovatta, T.; Kiehlmann, S.; Max-Moerbeck, W.; Readhead, A. C. S.; Reeves, R.; Pearson, T. J. "VHE gamma-ray detection of FSRQ QSO B1420+326 and modeling of its enhanced broadband state in 2020" *Astronomy and Astrophysics*, 647 :A163, 2021.
- Makhathini, S.; Mooley, K. P.; Brightman, M.; Hotokezaka, K.; Nayana, A. J.; Intema, H. T.; Dobie, D.; Lenc, E.; Perley, D. A.; Fremling, C.; Moldón, J.; Lazzati, D.; Kaplan, D. L.; Balasubramanian, A.; Brown, I. S.; Carbone, D.; Chandra, P.; Corsi, A.; Camilo, F.; Deller, A.; Frail, D. A.; Murphy, T.; Murphy, E. J.; Nakar, E.; Smirnov, O.; Beswick, R. J.; Fender, R.; Hallinan, G.; Heywood, I.; Kasliwal, M.; Lee, B.; Lu, W.; Rana, J.; Perkins, S.; White, S. V.; Józsa, G. I. G.; Hugo, B.; Kamphuis, P. "The Panchromatic Afterglow of GW170817: The Full Uniform Data Set, Modeling, Comparison with Previous Results, and Implications" *The Astrophysical Journal*, 922 :154, 2021.
- Malavasi, Nicola; Lee, Kyoung-Soo; Dey, Arjun; Xue, Rui; Huang, Yun; Shi, Ke "Ly $\alpha$  Line Properties at  $z = 3.78$  and Their Environmental Dependence: A Case Study around a Massive Protocluster" *The Astrophysical Journal*, 921 :103, 2021.
- Mangat, C. S.; Mckean, J. P.; Brilenkov, R.; Hartley, P.; Stacey, H. R.; Vegetti, S.; Wen, D. "PS J1721+8842: a gravitationally lensed dual AGN system at redshift 2.37 with two radio components" *Monthly Notices of the Royal Astronomical Society*, 508 :L64, 2021.
- Mangum, Jeffrey G. "Editorial" *Publications of the Astronomical Society of the Pacific*, 133 :120101, 2021.
- Manigand, S.; Coutens, A.; Loison, J.-C.; Wakelam, V.; Calcutt, H.; Müller, H. S. P.; Jørgensen, J. K.; Taquet, V.; Wampfler, S. F.; Bourke, T. L.; Kulterer, B. M.; Van Dishoeck, E. F.; Drozdovskaya, M. N.; Ligterink, N. F. W. "The ALMA-PILS survey: first detection of the unsaturated 3-carbon molecules Propenal (C<sub>2</sub>H<sub>3</sub>CHO) and Propylene (C<sub>3</sub>H<sub>6</sub>) towards IRAS 16293-2422 B" *Astronomy and Astrophysics*, 645 :A53, 2021.
- Marchal, Antoine; Martin, Peter G.; Gong, Munan "Resolving the Formation of Cold H I Filaments in the High-velocity Cloud Complex C" *The Astrophysical Journal*, 921 :11, 2021.
- Marchal, Antoine; Miville-Deschênes, Marc-Antoine "Thermal and Turbulent Properties of the Warm Neutral Medium in the Solar Neighborhood" *The Astrophysical Journal*, 908 :186, 2021.
- Marcos-Arenal, P.; Mendigutía, I.; Koumpia, E.; Oudmaijer, R. D.; Vioque, M.; Guzmán-Díaz, J.; Wichittanakom, C.; De Wit, W. J.; Montesinos, B.; Ilee, J. D. "K-band GRAVITY/VLTI interferometry of "extreme" Herbig Be stars. The size-luminosity relation revisited" *Astronomy and Astrophysics*, 652 :A68, 2021.
- Marecki, A. "Restarted activity in the 3C 328 radio galaxy" *Astronomy and Astrophysics*, 649 :L6, 2021.
- Marecki, A.; Jamroz, M.; Machalski, J.; Pajdosz-Śmierciak, U. "Multifrequency study of a double-double radio galaxy J0028+0035" *Monthly Notices of the Royal Astronomical Society*, 501 :853, 2021.
- Margot, Jean-Luc; Campbell, Donald B.; Giorgini, Jon D.; Jao, Joseph S.; Snedeker, Lawrence G.; Ghigo, Frank D.; Bonsall, Amber "Spin state and moment of inertia of Venus" *Nature Astronomy*, 5 :676, 2021.
- Margot, Jean-Luc; Pinchuk, Pavlo; Geil, Robert; Alexander, Stephen; Arora, Sparsh; Biswas, Swagata; Cebresos, Jose; Desai, Sanjana Prabhu; Duclos, Benjamin; Dunne, Riley; Lin Fu, Kristy Kwan; Goel, Shashwat; Gonzales, Julia; Gonzalez, Alexander; Jain, Rishabh; Lam, Adrian;

## APPENDIX A: PUBLICATIONS

- Lewis, Briley; Lewis, Rebecca; Li, Grace; Macdougall, Mason; Makarem, Christopher; Manan, Ivan; Molina, Eden; Nagib, Caroline; Neville, Kyle; O'Toole, Connor; Rockwell, Valerie; Rokushima, Yoichiro; Romanek, Griffin; Schmidgall, Carlyn; Seth, Samar; Shah, Rehan; Shimane, Yuri; Singhal, Myank; Tokadjian, Armen; Villafana, Lizvette; Wang, Zhixian; Yun, In; Zhu, Lujia; Lynch, Ryan S. "A Search for Technosignatures around 31 Sun-like Stars with the Green Bank Telescope at 1.15-1.73 GHz" *The Astronomical Journal*, 161 :55, 2021.
- Marscher, Alan P.; Jorstad, Svetlana G. "Frequency and Time Dependence of Linear Polarization in Turbulent Jets of Blazars" *Galaxies*, 9 :27, 2021.
- Martín, S.; Mangum, J. G.; Harada, N.; Costagliola, F.; Sakamoto, K.; Muller, S.; Aladro, R.; Tanaka, K.; Yoshimura, Y.; Nakanishi, K.; Herrero-Illana, R.; Mühle, S.; Aalto, S.; Behrens, E.; Colzi, L.; Emig, K. L.; Fuller, G. A.; García-Burillo, S.; Greve, T. R.; Henkel, C.; Holdship, J.; Humire, P.; Hunt, L.; Izumi, T.; Kohno, K.; König, S.; Meier, D. S.; Nakajima, T.; Nishimura, Y.; Padovani, M.; Rivilla, V. M.; Takano, S.; Van Der Werf, P. P.; Viti, S.; Yan, Y. T. "ALCHEMI, an ALMA Comprehensive High-resolution Extragalactic Molecular Inventory. Survey presentation and first results from the ACA array" *Astronomy and Astrophysics*, 656 :A46, 2021.
- Martín-Doménech, Rafael; Bergner, Jennifer B.; Öberg, Karin I.; Carpenter, John; Law, Charles J.; Huang, Jane; Jørgensen, Jes K.; Schwarz, Kamber; Wilner, David J. "Hot Corino Chemistry in the Class I Binary Source Ser-emb 11" *The Astrophysical Journal*, 923 :155, 2021.
- Mascoop, J. L.; Anderson, L. D.; Wenger, Trey. V.; Makai, Z.; Armentrout, W. P.; Balsler, Dana. S.; Bania, T. M. "The Galactic H II Region Luminosity Function at Radio and Infrared Wavelengths" *The Astrophysical Journal*, 910 :159, 2021.
- Maslej-Krešňáková, Viera; El Boucheffry, Khadija; Butka, Peter "Morphological classification of compact and extended radio galaxies using convolutional neural networks and data augmentation techniques" *Monthly Notices of the Royal Astronomical Society*, 505 :1464, 2021.
- Masqué, J. M.; Rodríguez, L. F.; Dzib, S. A.; Medina, S. N.; Loinard, L.; Trinidad, M. A.; Kurtz, S. E.; Rodríguez-Rico, C. A. "Exploring the Nature of Compact Radio Sources Associated to UCHII Regions" *Revista Mexicana de Astronomia y Astrofísica*, 57 :81, 2021.
- Matsumita, Yuko; Takahashi, Satoko; Ishii, Shun; Tomisaka, Kohji; Ho, Paul T. P.; Carpenter, John M.; Machida, Masahiro N. "Super-fast Rotation in the OMC 2/FIR 6b Jet" *The Astrophysical Journal*, 916 :23, 2021.
- Matthews, A. M.; Condon, J. J.; Cotton, W. D.; Mauch, T. "Source Counts Spanning Eight Decades of Flux Density at 1.4 GHz" *The Astrophysical Journal*, 909 :193, 2021.
- Matthews, A. M.; Condon, J. J.; Cotton, W. D.; Mauch, T. "Cosmic Star Formation History Measured at 1.4 GHz" *The Astrophysical Journal*, 914 :126, 2021.
- Maucó, Karina; Carrasco-González, Carlos; Schreiber, Matthias R.; Sierra, Anibal; Olofsson, Johan; Bayo, Amelia; Caceres, Claudio; Canovas, Hector; Palau, Aina "The Characterization of the Dust Content in the Ring Around Sz 91: Indications of Planetesimal Formation?" *The Astrophysical Journal*, 923 :128, 2021.
- Mazzilli Ciraulo, Barbara; Melchior, Anne-Laure; Maschmann, Daniel; Katkov, Ivan Yu.; Halle, Anaëlle; Combes, Françoise; Gelfand, Joseph D.; Al Yazeedi, Aisha "Two interacting galaxies hiding as one, revealed by MaNGA" *Astronomy and Astrophysics*, 653 :A47, 2021.
- Mccarthy, Michael C.; Lee, Kin Long Kelvin; Loomis, Ryan A.; Burkhardt, Andrew M.; Shingledecker, Christopher N.; Charnley, Steven B.; Cordiner, Martin A.; Herbst, Eric; Kalenskii, Sergei; Willis, Eric R.; Xue, Ci; Remijan, Anthony J.; Mcquire, Brett A. "Interstellar detection of the highly polar five-membered ring cyanocyclopentadiene" *Nature Astronomy*, 5 :p. 176-180, 2021.
- Mccarthy, Michael C.; Mcquire, Brett A. "Aromatics and Cyclic Molecules in Molecular Clouds: A New Dimension of Interstellar Organic Chemistry" *Journal of Physical Chemistry A*, 125 :3231, 2021.
- Mcquire, Brett A.; Loomis, Ryan A.; Burkhardt, Andrew M.; Lee, Kin Long Kelvin; Shingledecker, Christopher N.; Charnley, Steven B.; Cooke, Ilsa R.; Cordiner, Martin A.; Herbst, Eric; Kalenskii, Sergei; Siebert, Mark A.; Willis, Eric R.; Xue, Ci; Remijan, Anthony J.; Mccarthy, Michael C. "Detection of two interstellar polycyclic aromatic hydrocarbons via spectral matched filtering" *Science*, 371 :1265, 2021.
- Mckinney, J.; Armus, L.; Pope, A.; Díaz-Santos, T.; Charmandaris, V.; Inami, H.; Song, Y.; Evans, A. S. "Regulating Star Formation in Nearby Dusty Galaxies: Low Photoelectric Efficiencies in the Most Compact Systems" *The Astrophysical Journal*, 908 :238, 2021.
- Mcquinn, Kristen B. W.; Telidevara, Anjana K.; Fuson, Jackson; Adams, Elizabeth A. K.; Cannon, John M.; Skillman, Evan D.; Dolphin, Andrew E.; Haynes, Martha P.; Rhode, Katherine L.; Salzer, John. J.; Giovannelli, Riccardo; Gordon, Alex J. R. "Galaxy Properties at the Faint End of the H I Mass Function" *The Astrophysical Journal*, 918 :23, 2021.
- Medling, Anne M.; Kewley, Lisa J.; Calzetti, Daniela; Privon, George C.; Larson, Kirsten; Rich, Jeffrey A.; Armus, Lee; Allen, Mark G.; Bicknell, Geoffrey V.; Díaz-Santos, Tanio; Heckman, Timothy M.; Leitherer, Claus; Max, Claire E.; Rupke, David S. N.; Treister, Ezequiel; Messias, Hugo; Wagner, Alexander Y. "Tracing the Ionization Structure of the Shocked Filaments of NGC 6240" *The Astrophysical Journal*, 923 :160, 2021.
- Mège, P.; Russeil, D.; Zavagno, A.; Elia, D.; Molinari, S.; Brunt, C. M.; Butora, R.; Cambresy, L.; Di Giorgio, A. M.; Fenouillet, T.; Fukui, Y.; Lambert, J. C.; Makai, Z.; Merello, M.; Meunier, J. C.; Molinaro, M.; Moreau, C.; Pezzuto, S.; Poulin, Y.; Schisano, E.; Schuller, F. "Distance of HI-GAL sources" *Astronomy and Astrophysics*, 646 :A74, 2021.
- Meidt, Sharon E.; Leroy, Adam K.; Querejeta, Miguel; Schinnerer, Eva; Sun, Jiayi; Van Der Wel, Arjen; Emsellem, Eric; Henshaw, Jonathan; Hughes, Annie; Kruijssen, J. M. Diederik; Rosolowsky, Erik; Schrubba, Andreas; Barnes, Ashley; Bigiel, Frank; Blanc, Guillermo A.; Chevance, Melanie; Cao, Yixian; Dale, Daniel A.; Faesi, Christopher; Glover, Simon C. O.; Grasha, Kathryn; Groves, Brent; Herrera, Cynthia; Klessen, Ralf S.; Kreckel, Kathryn; Liu, Daizhong; Pan, Hsi-An; Pety, Jerome; Saito, Toshiaki; Usero, Antonio; Watkins, Elizabeth; Williams, Thomas G. "The Organization of Cloud-scale Gas Density Structure: High-resolution CO versus 3.6  $\mu\text{m}$  Brightness Contrasts in Nearby Galaxies" *The Astrophysical Journal*, 913 :113, 2021.
- Menezes, Fabian; Selhorst, Caius L.; Giménez De Castro, Carlos Guillermo; Valio, Adriana "The Subterahertz Solar Cycle: Polar and Equatorial Radii Derived from SST and ALMA" *The Astrophysical Journal*, 910 :77, 2021.
- Messias, Hugo G.; Hatziminaoglou, Evanthia; Hibon, Pascale; Mroczkowski, Tony; Matute, Israel; Lacy, Mark; Mason, Brian; Martín, Sergio; Afonso, José M.; Fomalont, Edward; Amarantidis, Stergios; Antón, Sonia; Demarco, Ricardo; Gendron-Marsolais, Marie-Lou; Hopkins, Andrew M.; Kneissl, Rüdiger; Lopez, Cristian; Rebolledo, David; Yang, Chentao "An ACA 1mm survey of HzRGs in the ELAIS-S1: survey description and first results" *Monthly Notices of the Royal Astronomical Society*, 508 :5259, 2021.
- Mhlahlo, N.; Jamroz, M. "Revealing the unusual structure of the KAT-7-discovered giant radio galaxy J0133-1302" *Monthly Notices of the Royal Astronomical Society*, 508 :2910, 2021.
- Michail, Joseph M.; Wardle, Mark; Yusef-Zadeh, Farhad; Kunneriath, Devaky "Multiwavelength Observations of Sgr A". I. 2019 July 18" *The Astrophysical Journal*, 923 :54, 2021.
- Michail, Joseph M.; Yusef-Zadeh, Farhad; Wardle, Mark "Detection of a 20-min time lag observed from Sgr A\* between 8 and 10 GHz with the VLA" *Monthly Notices of the Royal Astronomical Society*, 505 :3616, 2021.
- Michel, Arnaud; Van Der Marel, Nienke; Matthews, Brenda C. "Bridging the Gap between Protoplanetary and Debris Disks: Separate Evolution of Millimeter and Micrometer-sized Dust" *The Astrophysical Journal*, 921 :72, 2021.
- Michiyama, Tomonari; Saito, Toshiaki; Tadaki, Ken-Ichi; Ueda, Junko; Zhuang, Ming-Yang; Molina, Juan; Lee, Bumhyun; Wang, Ran; Bolatto, Alberto D.; Iono, Daisuke; Nakanishi, Kouichiro; Izumi, Takuma; Yamashita, Takuji; Ho, Luis C. "An ACA Survey of [C I] 3P1-3P0, CO J = 4 - 3, and Dust

- Continuum in Nearby U/LIRGs" *The Astrophysical Journal Supplement Series*, 257 :28, 2021.
- Miller, M. C.; Lamb, F. K.; Dittmann, A. J.; Bogdanov, S.; Arzoumanian, Z.; Gendreau, K. C.; Guillot, S.; Ho, W. C. G.; Lattimer, J. M.; Loewenstein, M.; Morsink, S. M.; Ray, P. S.; Wolff, M. T.; Baker, C. L.; Cazeau, T.; Manthripragada, S.; Markwardt, C. B.; Okajima, T.; Pollard, S.; Cognard, I.; Cromartie, H. T.; Fonseca, E.; Guillemot, L.; Kerr, M.; Parthasarathy, A.; Pennucci, T. T.; Ransom, S.; Stairs, I. "The Radius of PSR J0740+6620 from NICER and XMM-Newton Data" *The Astrophysical Journal*, 918 :L28, 2021.
- Miller-Jones, James C. A.; Bahramian, Arash; Orosz, Jerome A.; Mandel, Ilya; Gou, Lijun; Maccarone, Thomas J.; Neijssel, Coenraad J.; Zhao, Xueshan; Ziolkowski, Janusz; Reid, Mark J.; Uttley, Phil; Zheng, Xueying; Byun, Do-Young; Dodson, Richard; Grinberg, Victoria; Jung, Taehyun; Kim, Jeong-Sook; Marcote, Benito; Markoff, Sera; Rioja, María J.; Rushton, Anthony P.; Russell, David M.; Sivakoff, Gregory R.; Tetarenko, Alexandra J.; Tudose, Valeriu; Wilms, Joern "Cygnus X-1 contains a 21-solar mass black hole—Implications for massive star winds" *Science*, 371 :1046, 2021.
- Mills, E. A. C.; Gorski, M.; Emig, K. L.; Bolatto, A. D.; Levy, R. C.; Leroy, A. K.; Ginsburg, A.; Henshaw, J. D.; Zschaechner, L. K.; Velleux, S.; Tanaka, K.; Meier, D. S.; Walter, F.; Krieger, N.; Ott, J. "Clustered Star Formation in the Center of NGC 253 Contributes to Driving the Ionized Nuclear Wind" *The Astrophysical Journal*, 919 :105, 2021.
- Misra, K.; Resmi, L.; Kann, D. A.; Marongiu, M.; Moin, A.; Klose, S.; Bernardi, G.; De Ugarte Postigo, A.; Jaiswal, V. K.; Schulze, S.; Perley, D. A.; Ghosh, A.; Dimple, Kumar, H.; Gupta, R.; Michałowski, M. J.; Martín, S.; Cockeram, A.; Cherukuri, S. V.; Bhalerao, V.; Anderson, G. E.; Pandey, S. B.; Anupama, G. C.; Thöne, C. C.; Barway, S.; Wieringa, M. H.; Fynbo, J. P. U.; Habeeb, N. "Low frequency view of GRB 190114C reveals time varying shock micro-physics" *Monthly Notices of the Royal Astronomical Society*, 504 :5685, 2021.
- Missaglia, V.; Massaro, F.; Luzzo, E.; Paggi, A.; Kraft, R. P.; Forman, W. R.; Jimenez-Gallardo, A.; Madrid, J. P.; Ricci, F.; Stuardi, C.; Wilkes, B. J.; Baum, S. A.; O'Dea, C. P.; Kuraszkiewicz, J.; Tremblay, G. R.; Maselli, A.; Capetti, A.; Sani, E.; Balmaverde, B.; Harris, D. E. "Hidden Treasures in the Unknown 3CR Extragalactic Radio Sky: A Multiwavelength Approach" *The Astrophysical Journal Supplement Series*, 255 :18, 2021.
- Mitsuhashi, I.; Matsuda, Y.; Smail, Ian; Hayatsu, N. H.; Simpson, J. M.; Swinbank, A. M.; Umehata, H.; Dudzevičiūtė, U.; Birkin, J. E.; Ikarashi, S.; Chen, Chian-Chou; Tadaki, K.; Yajima, H.; Harikane, Y.; Inami, H.; Chapman, S. C.; Hatsukade, B.; Iono, D.; Bunker, A.; Ao, Y.; Saito, T.; Ueda, J.; Sakamoto, S. "FIR-luminous [C II] Emitters in the ALMA-SCUBA-2 COSMOS Survey (AS2COSMOS): The Nature of Submillimeter Galaxies in a 10 Comoving Megaparsec-scale Structure at  $z \sim 4.6$ " *The Astrophysical Journal*, 907 :122, 2021.
- Miura, R. E.; Espada, D.; Hirota, A.; Henkel, C.; Verley, S.; Kobayashi, M. I. N.; Matsushita, S.; Israel, F. P.; Vila-Vilaro, B.; Morokuma-Matsui, K.; Ott, J.; Vlahakis, C.; Peck, A. B.; Aalto, S.; Hogerheijde, M. R.; Neumayer, N.; Iono, D.; Kohno, K.; Takemura, H.; Komugi, S. "A Giant Molecular Cloud Catalog in the Molecular Disk of the Elliptical Galaxy NGC 5128 (Centaurus A)" *Monthly Notices of the Royal Astronomical Society*, 504 :pp.6198-6215, 2021.
- Miyamoto, Yusuke; Yasuda, Atsushi; Watanabe, Yoshimasa; Seta, Masumichi; Kuno, Nario; Salak, Dragan; Ishii, Shun; Nagai, Makoto; Nakai, Naomasa "Atomic carbon [C I](3P1-3P0) mapping of the nearby galaxy M 83" *Publications of the Astronomical Society of Japan*, 73 :552, 2021.
- Miyawaki, Ryosuke; Tsuboi, Masato; Uehara, Kenta; Miyazaki, Atsushi "Hot molecular core candidates in the Galactic center 50 km s<sup>-1</sup> molecular cloud" *Publications of the Astronomical Society of Japan*, 73 :943, 2021.
- Mizukoshi, Shoichiro; Kohno, Kotaro; Egusa, Fumi; Hatsukade, Bunyo; Minezaki, Takeo; Saito, Toshiaki; Tamura, Yoichi; Iono, Daisuke; Ueda, Junko; Matsuda, Yuichi; Kawabe, Ryohei; Lee, Minju M.; Yun, Min S.; Espada, Daniel "Physical Characterization of Serendipitously Uncovered Millimeter-wave Line-emitting Galaxies at  $z \sim 2.5$  behind the Local Luminous Infrared Galaxy VV 114" *The Astrophysical Journal*, 917 :94, 2021.
- Mochkovitch, R.; Daigne, F.; Duque, R.; Zitouni, H. "Prospects for kilonova signals in the gravitational-wave era" *Astronomy and Astrophysics*, 651 :A83, 2021.
- Mohan, A.; Wedemeyer, S.; Pandit, S.; Saberi, M.; Hauschildt, P. H. "EMISSA (Exploring Millimeter Indicators of Solar-Stellar Activity). I. The initial millimeter-centimeter main-sequence star sample" *Astronomy and Astrophysics*, 655 :A113, 2021.
- Molina, Juan; Wang, Ran; Shangguan, Jinyi; Ho, Luis C.; Bauer, Franz E.; Treister, Ezequiel; Shao, Yali "Compact Molecular Gas Distribution in Quasar Host Galaxies" *The Astrophysical Journal*, 908 :231, 2021.
- Molina, Mallory; Reines, Amy E.; Greene, Jenny E.; Darling, Jeremy; Condon, James J. "Outflows, Shocks, and Coronal Line Emission in a Radio-selected AGN in a Dwarf Galaxy" *The Astrophysical Journal*, 910 :5, 2021.
- Molina, Mallory; Reines, Amy E.; Latimer, Colin J.; Baldassare, Vivienne; Salehirad, Sheyda "A Sample of Massive Black Holes in Dwarf Galaxies Detected via [Fe X] Coronal Line Emission: Active Galactic Nuclei and/or Tidal Disruption Events" *The Astrophysical Journal*, 922 :155, 2021.
- Molnár, Dániel Cs; Sargent, Mark T.; Leslie, Sarah; Magnelli, Benjamin; Schinnerer, Eva; Zamorani, Giovanni; Delhaize, Jacinta; Smolčić, Veresa; Tisanić, Krešimir; Vardoulaki, Eleni "The non-linear infrared-radio correlation of low- $z$  galaxies: implications for redshift evolution, a new radio SFR recipe, and how to minimize selection bias" *Monthly Notices of the Royal Astronomical Society*, 504 :118, 2021.
- Molnar, Momchil E.; Reardon, Kevin P.; Cranmer, Steven R.; Kowalski, Adam F.; Chai, Yi; Gary, Dale "High-frequency Wave Power Observed in the Solar Chromosphere with IBIS and ALMA" *The Astrophysical Journal*, 920 :125, 2021.
- Molter, Edward M.; De Pater, Imke; Luszcz-Cook, Stacia; Tollefson, Joshua; Sault, Robert J.; Butler, Bryan; De Boer, David "Tropospheric Composition and Circulation of Uranus with ALMA and the VLA" *The Planetary Science Journal*, 2 :16 pp, 2021.
- Momjian, Emmanuel; Bañados, Eduardo; Carilli, Christopher L.; Walter, Fabian; Mazzucchelli, Chiara "Resolving the Radio Emission from the Quasar P172+18 at  $z = 6.82$ " *The Astronomical Journal*, 161 :207, 2021.
- Mondal, Suman Kumar; Gorai, Prasanta; Sil, Milan; Ghosh, Rana; Etim, Emmanuel E.; Chakrabarti, Sandip K.; Shimonishi, Takashi; Nakatani, Naoki; Furuya, Kenji; Tan, Jonathan C.; Das, Ankan "Is There Any Linkage between Interstellar Aldehyde and Alcohol?" *The Astrophysical Journal*, 922 :194, 2021.
- Mooney, Seán; Massaro, Francesco; Quinn, John; Capetti, Alessandro; Baldi, Ranieri D.; Gürkan, Gülay; Hardcastle, Martin J.; Horellou, Cathy; Mingo, Beatriz; Morganti, Raffaella; O'Sullivan, Shane; Pajdosz-Śmierciak, Urszula; Pandey-Pommier, Mamta; Röttgering, Huub "Characterising the Extended Morphologies of BL Lacertae Objects at 144 MHz with LOFAR" *The Astrophysical Journal Supplement Series*, 257 :30, 2021.
- Morgan, J.; Van Der Walt, D. J.; Chibueze, J. O.; Zhang, Q. "Orientation effect on the light-curve shape of periodic methanol maser sources" *Monthly Notices of the Royal Astronomical Society*, 507 :1138, 2021.
- Morganti, Raffaella; Oosterloo, Tom; Tadhunter, Clive; Bernhard, Emmanuel P.; Raymond Oonk, J. B. "Taking snapshots of the jet-ISM interplay: The case of PKS 0023-26" *Astronomy and Astrophysics*, 656 :A55, 2021.
- Morii, Kaho; Sanhueza, Patricio; Nakamura, Fumitaka; Jackson, James M.; Li, Shanghuo; Beuther, Henrik; Zhang, Qizhou; Feng, Siyi; Tafuya, Daniel; Guzmán, Andrés E.; Izumi, Natsuko; Sakai, Takeshi; Lu, Xing; Tatematsu, Ken'ichi; Ohashi, Satoshi; Silva, Andrea; Olguin, Fernando A.; Contreras, Yanett "The ALMA Survey of 70  $\mu\text{m}$  Dark High-mass Clumps in Early Stages (ASHES). IV. Star Formation Signatures in G023.477" *The Astrophysical Journal*, 923 :147, 2021.

## APPENDIX A: PUBLICATIONS

- Morii, Kaho; Takahashi, Satoko; Machida, Masahiro N. "Revealing a Centrally Condensed Structure in OMC-3/MMS 3 with ALMA High-resolution Observations" *The Astrophysical Journal*, 910 :148, 2021.
- Morishita, T.; D'Amato, Q.; Abramson, L. E.; Abdurro'Uf; Stiavelli, M.; Lucas, R. A. "Extremely Low Molecular Gas Content in the Vicinity of a Red Nugget Galaxy at  $z = 1.91$ " *The Astrophysical Journal*, 908 :163, 2021.
- Moscadelli, L.; Beuther, H.; Ahmadi, A.; Gieser, C.; Massi, F.; Cesaroni, R.; Sánchez-Monge, Á.; Bacciotti, F.; Beltrán, M. T.; Csengeri, T.; Galván-Madrid, R.; Henning, Th.; Klaassen, P. D.; Kuiper, R.; Leurini, S.; Longmore, S. N.; Maud, L. T.; Möller, T.; Palau, A.; Peters, T.; Pudritz, R. E.; Sanna, A.; Semenov, D.; Urquhart, J. S.; Winters, J. M.; Zinnecker, H. "Multi-scale view of star formation in IRAS 21078+5211: from clump fragmentation to disk wind" *Astronomy and Astrophysics*, 647 :A14, 2021.
- Moscadelli, L.; Cesaroni, R.; Beltrán, M. T.; Rivilla, V. M. "The ionized heart of a molecular disk. ALMA observations of the hyper-compact HII region G24.78+0.08 A1" *Astronomy and Astrophysics*, 650 :A142, 2021.
- Mufakharov, T.; Mikhailov, A.; Sotnikova, Yu.; Mingaliev, M.; Stolyarov, V.; Erkenov, A.; Nizhelskij, N.; Tsybulev, P. "Flux-density measurements of the high-redshift blazar PSO J047.4478+27.2992 at 4.7 and 8.2 GHz with RATAN-600" *Monthly Notices of the Royal Astronomical Society*, 503 :4662, 2021.
- Müller, Ancla; Poggianti, Bianca Maria; Pfrommer, Christoph; Adebahr, Björn; Serra, Paolo; Ignesti, Alessandro; Sparre, Martin; Gitti, Myriam; Dettmar, Ralf-Jürgen; Vulcani, Benedetta; Moretti, Alessia "Highly ordered magnetic fields in the tail of the jellyfish galaxy J0206" *Nature Astronomy*, 5 :p. 159-168, 2021.
- Muller, S.; Ubachs, W.; Menten, K. M.; Henkel, C.; Kanekar, N. "A study of submillimeter methanol absorption toward PKS 1830-211: Excitation, invariance of the proton-electron mass ratio, and systematics" *Astronomy and Astrophysics*, 652 :A5, 2021.
- Mun, Jae Yeon; Hwang, Ho Seong; Lee, Myung Gyoong; Chung, Aeree; Yoon, Hyein; Lee, Jong Chul "Star Formation Activity of Galaxies Undergoing Ram Pressure Stripping in the Virgo Cluster" *Journal of Korean Astronomical Society*, 54 :17, 2021.
- Murase, Kohta; Omand, Conor M. B.; Coppejans, Deanne L.; Nagai, Hiroshi; Bower, Geoffrey C.; Chornock, Ryan; Fox, Derek B.; Kashiyama, Kazumi; Law, Casey; Margutti, Raffaella; Mészáros, Peter "ALMA and NOEMA constraints on synchrotron nebular emission from embryonic superluminous supernova remnants and radio-gamma-ray connection" *Monthly Notices of the Royal Astronomical Society*, 508 :44, 2021.
- Murchikova, Lena; Witzel, Gunther "Second-scale Submillimeter Variability of Sagittarius A\* during Flaring Activity of 2019: On the Origin of Bright Near-infrared Flares" *The Astrophysical Journal*, 920 :L7, 2021.
- Murphy, Tara; Kaplan, David L.; Stewart, Adam J.; O'Brien, Andrew; Lenc, Emil; Pintaldi, Sergio; Pritchard, Joshua; Dobie, Dougal; Fox, Archibald; Leung, James K.; An, Tao; Bell, Martin E.; Broderick, Jess W.; Chatterjee, Shami; Dai, Shi; D'Antonio, Daniele; Doyle, Gerry; Gaensler, B. M.; Heald, George; Horesh, Assaf; Jones, Megan L.; McConnell, David; Moss, Vanessa A.; Raja, Wasim; Ramsay, Gavin; Ryder, Stuart; Sadler, Elaine M.; Sivakoff, Gregory R.; Wang, Yuanming; Wang, Ziteng; Wheatland, Michael S.; Whiting, Matthew; Allison, James R.; Anderson, C. S.; Ball, Lewis; Bannister, K.; Bock, D. C.-J.; Bolton, R.; Bunton, J. D.; Chekkala, R.; Chippendale, A. P.; Cooray, F. R.; Gupta, N.; Hayman, D. B.; Jeganathan, K.; Koribalski, B.; Lee-Waddell, K.; Mahony, Elizabeth K.; Marvil, J.; McClure-Griffiths, N. M.; Mirschin, P.; Ng, A.; Pearce, S.; Phillips, C.; Voronkov, M. A. "The ASKAP Variables and Slow Transients (VAST) Pilot Survey" *Publications of the Astronomical Society of Australia*, 38 :e054, 2021.
- Murray, Claire E.; Stanimirović, Snežana; Heiles, Carl; Dickey, John M.; McClure-Griffiths, N. M.; Lee, M.-Y.; M. Goss, W.; Killerby-Smith, Nicholas "The MACH HI Absorption Survey. I. Physical Conditions of Cold Atomic Gas outside of the Galactic Plane" *The Astrophysical Journal Supplement Series*, 256 :37, 2021.
- Murthy, Suma; Morganti, Raffaella; Oosterloo, Tom; Maccagni, Filippo M. "The H I absorption zoo: JVLA extension to  $z = 0.4$ " *Astronomy and Astrophysics*, 654 :A94, 2021.
- Mutic, M. M.; Chibueze, J. O.; El Boucheffy, K.; Macleod, G. C.; Morgan, J.; Baki, P. "Massive protocluster of a periodic maser source G188.95+0.89" *Monthly Notices of the Royal Astronomical Society*, 506 :4175, 2021.
- Myserlis, Ioannis; Contopoulos, Ioannis "An underlying universal pattern in galaxy halo magnetic fields" *Astronomy and Astrophysics*, 649 :A94, 2021.
- Nagai, H.; Kawakatu, N. "Diffuse Synchrotron Emission Associated with the Starburst in the Circumnuclear Disk of NGC 1275" *The Astrophysical Journal*, 914 :L11, 2021.
- Nakata, Ryo; Hayashida, Kiyoshi; Noda, Hirofumi; Yoneyama, Tomokage; Matsumoto, Hironori; Imanishi, Masatoshi "Spatially resolved X-ray spectroscopy of the archetype type 2 active galactic nucleus NGC 1068 with Chandra" *Publications of the Astronomical Society of Japan*, 73 :338, 2021.
- Nandi, S.; Caproni, A.; Kharb, P.; Sebastian, B.; Roy, R. "Double-peaked Lines, Dual VLBI Components, and Precessing Jets in J1328+2752" *The Astrophysical Journal*, 908 :178, 2021.
- Narayan, Ramesh; Palumbo, Daniel C. M.; Johnson, Michael D.; Gelles, Zachary; Himwich, Elizabeth; Chang, Dominic O.; Ricarte, Angelo; Dexter, Jason; Gammie, Charles F.; Chael, Andrew A.; Event Horizon Telescope Collaboration; Akiyama, Kazunori; Alberdi, Antxon; Alef, Walter; Algaba, Juan Carlos; Anantua, Richard; Asada, Keiichi; Azular, Rebecca; Baczko, Anne-Kathrin; Ball, David; Baloković, Mislav; Barrett, John; Benson, Bradford A.; Bintley, Dan; Blackburn, Lindy; Blundell, Raymond; Boland, Wilfred; Bouman, Katherine L.; Bower, Geoffrey C.; Boyce, Hope; Bremer, Michael; Brinkerink, Christiaan D.; Brissenden, Roger; Britzen, Silke; Broderick, Avery E.; Brogiere, Dominique; Bronzwaer, Thomas; Byun, Do-Young; Carlstrom, John E.; Chan, Chi-Kwan; Chatterjee, Shami; Chatterjee, Koushik; Chen, Ming-Tang; Chen, Yongjun; Chesler, Paul M.; Cho, Ilje; Christian, Pierre; Conway, John E.; Cordes, James M.; Crawford, Thomas M.; Crew, Geoffrey B.; Cruz-Orsorio, Alejandro; Cui, Yuzhu; Davelaar, Jordy; De Laurentis, Mariafelicia; Deane, Roger; Dempsey, Jessica; Desvignes, Gregory; Doeleman, Sheperd S.; Eatough, Ralph P.; Falcke, Heino; Farah, Joseph; Fish, Vincent L.; Fomalont, Ed; Ford, H. Alyson; Fraga-Encinas, Raquel; Friberg, Per; Fromm, Christian M.; Fuentes, Antonio; Galison, Peter; García, Roberto; Gentaz, Olivier; Georgiev, Boris; Goddi, Ciriaco; Gold, Roman; Gómez, José L.; Gómez-Ruiz, Arturo I.; Gu, Minfeng; Gurwell, Mark; Hada, Kazuhiro; Haggard, Daryl; Hecht, Michael H.; Hesper, Ronald; Ho, Luis C.; Ho, Paul; Honma, Mareki; Huang, Chih-Wei L.; Huang, Lei; Hughes, David H.; Ikeda, Shiro; Inoue, Makoto; Issaoun, Sara; James, David J.; Jannuzi, Buell T.; Janssen, Michael; Jeter, Britton; Jiang, Wu; Jimenez-Rosales, Alejandra; Jorstad, Svetlana; Jung, Taehyun; Karami, Mansour; Karuppusamy, Ramesh; Kawashima, Tomohisa; Keating, Garrett K.; Kettenis, Mark; Kim, Dong-Jin; Kim, Jae-Young; Kim, Jongsoo; Kim, Junhan; Kino, Motoki; Koay, Jun Yi; Kofuji, Yutaro; Koch, Patrick M.; Koyama, Shoko; Kramer, Michael; Kramer, Carsten; Krichbaum, Thomas P.; Kuo, Cheng-Yu; Lauer, Tod R.; Lee, Sang-Sung; Levis, Aviad; Li, Yan-Rong; Li, Zhiyuan; Lindqvist, Michael; Lico, Rocco; Lindahl, Greg; Liu, Jun; Liu, Kuo; Liuzzo, Elisabetta; Lo, Wen-Ping; Lobanov, Andrei P.; Loinard, Laurent; Lonsdale, Colin; Lu, Ru-Sen; Macdonald, Nicholas R.; Mao, Jirong; Marchili, Nicola; Markoff, Sera; Marrone, Daniel P.; Marscher, Alan P.; Martí-Vidal, Iván; Matsushita, Satoki; Matthews, Lynn D.; Medeiros, Lia; Menten, Karl M.; Mizuno, Izumi; Mizuno, Yosuke; Moran, James M.; Moriyama, Kotaro; Moscibrodzka, Monika; Müller, Cornelia; Musoke, Gibwa; Mejías, Alejandro; Mus, Nagai, Hiroshi; Nagar, Neil M.; Nakamura, Masanori; Narayanan, Gopal; Natarajan, Iniyana; Nathanail, Antonios; Neilsen, Joey; Neri, Roberto; Ni, Chunchong; Noutsos, Aristeidis; Nowak, Michael A.; Okino, Hiroki; Olivares, Héctor; Ortiz-León, Gisela N.; Oyama, Tomoaki; Özel, Feryal; Park, Jongho; Patel, Nimesh; Pen, Ue-

- Li; Pesce, Dominic W.; Piétu, Vincent; Plambeck, Richard; Popstefanija, Aleksandar; Porth, Oliver; Pözl, Felix M.; Prather, Ben; Preciado-López, Jorge A.; Psaltis, Dimitrios; Pu, Hung-Yi; Ramakrishnan, Venkatesh; Rao, Ramprasad; Rawlings, Mark G.; Raymond, Alexander W.; Rezzolla, Luciano; Ripperda, Bart; Roelofs, Freek; Rogers, Alan; Ros, Eduardo; Rose, Mel; Roshanineshat, Arash; Rottmann, Helge; Roy, Alan L.; Ruzsczyk, Chet; Rygl, Kazi L. J.; Sánchez, Salvador; Sánchez-Arguelles, David; Sasada, Mahito; Savolainen, Tuomas; Schloerb, F. Peter; Schuster, Karl-Friedrich; Shao, Lijing; Shen, Zhiqiang; Small, Des; Sohn, Bong Won; Soohoo, Jason; Sun, He; Tazaki, Fumie; Tetarenko, Alexandra J.; Tiede, Paul; Tilanus, Remo P. J.; Titus, Michael; Toma, Kenji; Torne, Pablo; Trent, Tyler; Traianou, Ethalia; Trippe, Sascha; Van Bemmell, Ilse; Van Langevelde, Huib Jan; Van Rossum, Daniel R.; Wagner, Jan; Ward-Thompson, Derek; Wardle, John; Weintraub, Jonathan; Wex, Norbert; Wharton, Robert; Wielgus, Maciek; Wong, George N.; Wu, Qingwen; Yoon, Doosoo; Young, André; Young, Ken; Younsi, Ziri; Yuan, Feng; Yuan, Ye-Fei; Zensus, J. Anton; Zhao, Guang-Yao; Zhao, Shan-Shan "The Polarized Image of a Synchrotron-emitting Ring of Gas Orbiting a Black Hole" *The Astrophysical Journal*, 912 :35, 2021.
- Narayanan, Desika; Turk, Matthew J.; Robitaille, Thomas; Kelly, Ashley J.; McClellan, B. Connor; Sharma, Ray S.; Garg, Prerak; Abuzzo, Matthew; Choi, Ena; Conroy, Charlie; Johnson, Benjamin D.; Kimock, Benjamin; Li, Qi; Lovell, Christopher C.; Lower, Sidney; Privon, George C.; Roberts, Jonathan; Sethuram, Snigdha; Snyder, Gregory F.; Thompson, Robert; Wise, John H. "POWDERDAY: Dust Radiative Transfer for Galaxy Simulations" *The Astrophysical Journal Supplement Series*, 252 :12, 2021.
- Nayak, O.; Meixner, M.; Okada, Y.; Lee, M. Y.; Chevance, M.; Buchbender, C.; Fukui, Y.; Onishi, T.; Parikka, A.; Stutzki, J. "Stellar Feedback on the Earliest Stage of Massive Star Formation" *The Astrophysical Journal*, 907 :106, 2021.
- Nazari, P.; Van Gelder, M. L.; Van Dishoeck, E. F.; Tabone, B.; Van'T Hoff, M. L. R.; Ligterink, N. F. W.; Beuther, H.; Boogert, A. C. A.; Caratti O Garatti, A.; Klaassen, P. D.; Linnartz, H.; Taquet, V.; Tychoniec, Ł. "Complex organic molecules in low-mass protostars on Solar System scales. II. Nitrogen-bearing species" *Astronomy and Astrophysics*, 650 :A150, 2021.
- Niederlander, Ava; Hughes, A. Meredith; Fehr, Anna J.; Flaherty, Kevin M.; Su, Kate Y. L.; Moór, Attila; Chiang, Eugene; Andrews, Sean M.; Wilner, David J.; Marino, Sebastian "Resolving Structure in the Debris Disk around HD 206893 with ALMA" *The Astrophysical Journal*, 917 :5, 2021.
- Neelamkandan, Naslim; Tokuda, Kazuki; Barman, Susmita; Kondo, Hiroshi; Sano, Hidetoshi; Onishi, Toshikazu "ALMA Reveals a Cloud-Cloud Collision that Triggers Star Formation in the Small Magellanic Cloud" *The Astrophysical Journal*, 908 :L43, 2021.
- Neelaman, Marcel; Novak, Mladen; Venemans, Bram P.; Walter, Fabian; Decarli, Roberto; Kaasinen, Melanie; Schindler, Jan-Torge; Bañados, Eduardo; Carilli, Chris L.; Drake, Alyssa B.; Fan, Xiaohui; Rix, Hans-Walter "The Kinematics of  $z \sim 6$  Quasar Host Galaxies" *The Astrophysical Journal*, 911 :141, 2021.
- Nelson, Thomas; Mukai, Koji; Chomiuk, Laura; Sokoloski, Jennifer L.; Linford, Justin D.; Finzell, Thomas; Mioduszewski, Amy J.; Rupen, Michael P.; Weston, Jennifer; Lopes De Oliveira, Raimundo "X-ray evolution of the nova V959 Mon suggests a delayed ejection and a non-radiative shock" *Monthly Notices of the Royal Astronomical Society*, 500 :2798, 2021.
- Neronov, Andrii; Pol, Alberto Roper; Caprini, Chiara; Semikoz, Dmitri "NANOGrav signal from magnetohydrodynamic turbulence at the QCD phase transition in the early Universe" *Physical Review D*, 103 :L041302, 2021.
- Nesci, R.; Cutini, S.; Stanghellini, C.; Martinelli, F.; Maselli, A.; Lipunov, V. M.; Kornilov, V.; Lopez, R. R.; Siviero, A.; Giroletti, M.; Orienti, M. "Multiwavelength flare observations of the blazar S5 1803+784" *Monthly Notices of the Royal Astronomical Society*, 502 :6177, 2021.
- Nesvadba, N. P. H.; Wagner, A. Y.; Mukherjee, D.; Mandal, A.; Janssen, R. M. J.; Zovaro, H.; Neumayer, N.; Bagchi, J.; Bicknell, G. "Jet-driven AGN feedback on molecular gas and low star-formation efficiency in a massive local spiral galaxy with a bright X-ray halo" *Astronomy and Astrophysics*, 654 :A8, 2021.
- Ngoc, Nguyen Bich; Diep, Pham Ngoc; Parsons, Harriet; Pattle, Kate; Hoang, Thiem; Ward-Thompson, Derek; Tram, Le Ngoc; Hull, Charles L. H.; Tahani, Mehrnoosh; Furuya, Ray; Bastien, Pierre; Qiu, Keping; Hasegawa, Tetsuo; Kwon, Woojin; Doi, Yasuo; Lai, Shih-Ping; Coudé, Simon; Berry, David; Ching, Tao-Chung; Hwang, Jihye; Soam, Archana; Wang, Jia-Wei; Arzoumanian, Doris; Bourke, Tyler L.; Byun, Do-Young; Chen, Hui-Ru Vivien; Chen, Zhiwei; Chen, Wen Ping; Chen, Mike; Cho, Jungyeon; Choi, Yunhee; Choi, Minh; Chrysostomou, Antonio; Chung, Eun Jung; Dai, Sophia; Di Francesco, James; Duan, Yan; Duan, Hao-Yuan; Eden, David; Eswaraiah, Chakali; Fanciullo, Lapo; Fiege, Jason; Fissel, Laura M.; Franzmann, Erica; Friberg, Per; Friesen, Rachel; Fuller, Gary; Gledhill, Tim; Graves, Sarah; Greaves, Jane; Griffin, Matt; Gu, Qilao; Han, Ilseung; Hatchell, Jennifer; Hayashi, Saeko; Houde, Martin; Inoue, Tsuyoshi; Inutsuka, Shu-Ichiro; Iwasaki, Kazunari; Jeong, Il-Gyo; Johnstone, Doug; Kang, Ji-Hyun; Kang, Sung-Ju; Kang, Miju; Kataoka, Akimasa; Kawabata, Koji; Kemper, Francisca; Kim, Kee-Tae; Kim, Jongsoo; Pyo, Tae-Soo; Qian, Lei; Rao, Ramprasad; Rawlings, Mark; Rawlings, Jonathan; Retter, Brendan; Richer, John; Rigby, Andrew; Sadavoy, Sarah; Saito, Hiro; Savini, Giorgio; Scaife, Anna; Seta, Masumichi; Kim, Gwanjeong; Kim, Shinyoung; Kim, Kyoung Hee; Kim, Mi-Ryang; Kirchsclager, Florian; Kirk, Jason; Kobayashi, Masato I. N.; Koch, Patrick M.; Konyves, Vera; Kusune, Takayoshi; Kwon, Jungmi; Lacaille, Kevin; Law, Chi-Yan; Lee, Sang-Sung; Lee, Yong-Hee; Lee, Chin-Fei; Lee, Jeong-Eun; Lee, Hyeeseung; Lee, Chang Won; Li, Di; Li, Hua-Bai; Li, Dalei; Liu, Hong-Li; Liu, Junhao; Liu, Tie; Liu, Sheng-Yuan; Lu, Xing; Lyo, A. -Ran; Mairs, Steve; Matsumura, Masafumi; Matthews, Brenda; Moriarty-Schieven, Gerald; Nagata, Tetsuya; Nakamura, Fumitaka; Nakanishi, Hiroyuki; Ohashi, Nagayoshi; Onaka, Takashi; Park, Geumsook; Peretto, Nicolas; Shimajiri, Yoshito; Shinnaga, Hiroko; Tamura, Motohide; Tang, Ya-Wen; Tang, Xindi; Tomisaka, Kohji; Tsukamoto, Yusuke; Viti, Serena; Wang, Hongchi; Whitworth, Anthony; Xie, Jinjin; Yen, Hsi-Wei; Yoo, Hyunju; Yuan, Jinghua; Yun, Hyeong-Sik; Zenko, Tetsuya; Zhang, Yapeng; Zhang, Chuan-Peng; Zhang, Guoyin; Zhou, Jianjun; Zhu, Lei; De Looze, Ilse; André, Philippe; Dowell, C. Darren; Eyres, Stewart; Falle, Sam; Robitaille, Jean-François; Van Loo, Sven "Observations of Magnetic Fields Surrounding LkHα 101 Taken by the BISTRO Survey with JCMT-POL-2" *The Astrophysical Journal*, 908 :10, 2021.
- Nguyen, Dieu D.; Izumi, Takuma; Thater, Sabine; Imanishi, Masatoshi; Kawamuro, Taiki; Baba, Shunsuke; Nakano, Suzuka; Turner, Jean L.; Kohno, Kotaro; Matsushita, Satoki; Martín, Sergio; Meier, David S.; Nguyen, Phuong M.; Nguyen, Lam T. "Black hole mass measurement using ALMA observations of [C I] and CO emissions in the Seyfert 1 galaxy NGC 7469" *Monthly Notices of the Royal Astronomical Society*, 504 :4123, 2021.
- Nguyen, H.; Rugel, M. R.; Menten, K. M.; Brunthaler, A.; Dzib, S. A.; Yang, A. Y.; Kauffmann, J.; Pillai, T. G. S.; Nandakumar, G.; Schultheis, M.; Urquhart, J. S.; Dokara, R.; Gong, Y.; Medina, S. -N. X.; Ortiz-León, G. N.; Reich, W.; Wyrowski, F.; Beuther, H.; Cotton, W. D.; Csengeri, T.; Pandian, J. D.; Roy, N. "A global view on star formation: The GLOSTAR Galactic plane survey. IV. Radio continuum detections of young stellar objects in the Galactic Centre region" *Astronomy and Astrophysics*, 651 :A88, 2021.
- Nhung, P. T.; Hoai, D. T.; Tuan-Anh, P.; Darriulat, P.; Diep, P. N.; Ngoc, N. B.; Phuong, N. T.; Thai, T. T. "Morpho-kinematics of the circumstellar envelope of the AGB star R Dor: a global view" *Monthly Notices of the Royal Astronomical Society*, 504 :2687, 2021.
- Ni, Qingling; Brandt, W. N.; Chen, Chien-Ting; Luo, Bin; Nyland, Kristina; Yang, Guang; Zou, Fan; Aird, James; Alexander, David M.; Bauer, Franz Erik;

## APPENDIX A: PUBLICATIONS

- Lacy, Mark; Lehmer, Bret D.; Mallick, Labani; Salvato, Mara; Schneider, Donald P.; Tozzi, Paolo; Traulsen, Iris; Vaccari, Mattia; Vignali, Cristian; Vito, Fabio; Xue, Yongquan; Banerji, Manda; Chow, Kate; Comastri, Andrea; Del Moro, Agnese; Gilli, Roberto; Mullaney, James; Paolillo, Maurizio; Schwobe, Axel; Shemmer, Ohad; Sun, Mouyuan; Timlin, John D., Iii; Trump, Jonathan R. "The XMM-SERVS Survey: XMM-Newton Point-source Catalogs for the W-CDF-S and ELAIS-S1 Fields" *The Astrophysical Journal Supplement Series*, 256 :21, 2021.
- Nicuesa Guelbenzu, A. M.; Klose, S.; Schady, P.; Greiner, J.; Hartmann, D. H.; Hunt, L. K.; Magnelli, B.; Masetti, N.; Michałowski, M. J.; Palazzi, E.; Rossi, A.; Wieringa, M.; Stecklum, B. "The host galaxy of the short GRB 050709" *Astronomy and Astrophysics*, 650 :A17, 2021.
- Nikiel-Wroczyński, Błażej "Somewhere in between: Tracing the Radio Emission from Galaxy Groups (or Why Does the Future of Observing Galaxy Groups with Radio Telescopes Look Promising?)" *Galaxies*, 9 :84, 2021.
- Nindos, A.; Patsourakos, S.; Alissandrakis, C. E.; Bastian, T. S. "ALMA observations of the variability of the quiet Sun at millimeter wavelengths" *Astronomy and Astrophysics*, 652 :A92, 2021.
- Nomura, Hideko; Tsukagoshi, Takashi; Kawabe, Ryohei; Muto, Takayuki; Kanagawa, Kazuhiro D.; Aikawa, Yuri; Akiyama, Eiji; Okuzumi, Satoshi; Ida, Shigeru; Lee, Seokho; Walsh, Catherine; Millar, T. J. "High Spatial Resolution Observations of Molecular Lines toward the Protoplanetary Disk around TW Hya with ALMA" *The Astrophysical Journal*, 914 :113, 2021.
- Norfolk, Brodie J.; Maddison, Sarah T.; Marshall, Jonathan P.; Kennedy, Grant M.; Duchêne, Gaspard; Wilner, David J.; Pinte, Christophe; Moór, Attila; Matthews, Brenda; Abraham, Péter; Kóspál, Ágnes; Van Der Marel, Nienke "Four new planetesimals around typical and pre-main-sequence stars (PLATYPUS) debris discs at 8.8 mm" *Monthly Notices of the Royal Astronomical Society*, 507 :3139, 2021.
- Norfolk, Brodie J.; Maddison, Sarah T.; Pinte, Christophe; Van Der Marel, Nienke; Booth, Richard A.; Francis, Logan; Gonzalez, Jean-François; Ménard, François; Wright, Chris M.; Van Der Plas, Gerrit; Garg, Himanshi "Dust traps and the formation of cavities in transition discs: a millimetre to sub-millimetre comparison survey" *Monthly Notices of the Royal Astronomical Society*, 502 :5779, 2021.
- Norris, Ray P.; Intema, Huib T.; Kapińska, Anna D.; Koribalski, Bärbel S.; Lenc, Emil; Rudnick, L.; Alsaber, Rami Z. E.; Anderson, Craig; Anderson, G. E.; Crawford, E.; Crocker, Roland; English, Jayanne; Filipović, Miroslav D.; Galvin, Tim J.; Hopkins, Andrew M.; Hurley-Walker, Natasha; Inoue, Susumu; Luken, Kieran; Macgregor, Peter J.; Manojlović, Pero; Marvil, Josh; O'Brien, Andrew N.; Park, Laurence; Raja, Wasim; Shobhana, Devika; Venturi, Tiziana; Collier, Jordan D.; Hale, Catherine; Hotan, Aidan; Moss, Vanessa; Whiting, Matthew "Unexpected circular radio objects at high Galactic latitude" *Publications of the Astronomical Society of Australia*, 38 :e003, 2021.
- Norris, Ray P.; Marvil, Joshua; Collier, J. D.; Kapińska, Anna D.; O'Brien, Andrew N.; Rudnick, L.; Andernach, Heinz; Asorey, Jacobo; Brown, Michael J. I.; Brüggem, Marcus; Crawford, Evan; English, Jayanne; Rahman, Syed Faisal Ur; Filipović, Miroslav D.; Gordon, Yjan; Gürkan, Gülay; Hale, Catherine; Hopkins, Andrew M.; Huynh, Minh T.; Hyeonghan, Kim; James Jee, M.; Koribalski, Bärbel S.; Lenc, Emil; Luken, Kieran; Parkinson, David; Prandoni, Isabella; Raja, Wasim; Reiprich, Thomas H.; Riseley, Christopher J.; Shabala, Stanislav S.; Sheil, Jaimie R.; Vernstrom, Tessa; Whiting, Matthew T.; Allison, James R.; Anderson, C. S.; Ball, Lewis; Bell, Martin; Bunton, John; Galvin, T. J.; Gupta, Neeraj; Hotan, Aidan; Jacka, Colin; Macgregor, Peter J.; Mahony, Elizabeth K.; Maio, Umberto; Moss, Vanessa; Pandey-Pommier, M.; Voronkov, Maxim A. "The Evolutionary Map of the Universe pilot survey" *Publications of the Astronomical Society of Australia*, 38 :e046, 2021.
- North, Eve V.; Davis, Timothy A.; Bureau, Martin; Gaspari, Massimo; Cappellari, Michele; Iguchi, Satoru; Liu, Lijie; Onishi, Kyoko; Sarzi, Marc; Smith, Mark D.; Williams, Thomas G. "WISDOM project - VIII. Multiscale feedback cycles in the brightest cluster galaxy NGC 0708" *Monthly Notices of the Royal Astronomical Society*, 503 :5179, 2021.
- Nucamendi, Ulises; Herrera-Aguilar, Alfredo; Lizardo-Castro, Raúl; López-Cruz, Omar "Toward the Gravitational Redshift Detection in NGC 4258 and the Estimation of Its Black Hole Mass-to-distance Ratio" *The Astrophysical Journal*, 917 :L14, 2021.
- Nyamai, M. M.; Chomiuk, L.; Ribeiro, V. A. R. M.; Woudt, P. A.; Strader, J.; Sokolovsky, K. V. "Radio light curves and imaging of the helium nova V445 Puppis reveal seven years of synchrotron emission" *Monthly Notices of the Royal Astronomical Society*, 501 :1394, 2021.
- Ó Fionnagáin, D.; Vidotto, A. A.; Petit, P.; Neiner, C.; Manchester, W., Iv; Folsom, C. P.; Hallinan, G. "λ And: a post-main-sequence wind from a solar-mass star" *Monthly Notices of the Royal Astronomical Society*, 500 :3438, 2021.
- Öberg, Karin I.; Cleeves, L. Ilse; Bergner, Jennifer B.; Cavanaro, Joseph; Teague, Richard; Huang, Jane; Loomis, Ryan A.; Bergin, Edwin A.; Blake, Geoffrey A.; Calahan, Jenny; Cazzoletti, Paolo; Guzmán, Viviana Veloso; Hogerheijde, Michiel R.; Kama, Mihkel; Terwisscha Van Scheltinga, Jeroen; Qi, Chunhua; Van Dishoeck, Ewine; Walsh, Catherine; Wilner, David J. "The TW Hya Rosetta Stone Project. I. Radial and Vertical Distributions of DCN and DCO+" *The Astronomical Journal*, 161 :38, 2021.
- Öberg, Karin I.; Guzmán, Viviana V.; Walsh, Catherine; Aikawa, Yuri; Bergin, Edwin A.; Law, Charles J.; Loomis, Ryan A.; Alarcón, Felipe; Andrews, Sean M.; Bae, Jaehan; Bergner, Jennifer B.; Boehler, Yann; Booth, Alice S.; Bosman, Arthur D.; Calahan, Jenny K.; Cataldi, Gianni; Cleeves, L. Ilse; Czekala, Ian; Furuya, Kenji; Huang, Jane; Ilee, John D.; Kurtovic, Nicolas T.; Le Gal, Romane; Liu, Yao; Long, Feng; Ménard, François; Nomura, Hideko; Pérez, Laura M.; Qi, Chunhua; Schwarz, Kamber R.; Sierra, Anibal; Teague, Richard; Tsukagoshi, Takashi; Yamato, Yoshihide; Van'T Hoff, Merel L. R.; Waggoner, Abygail R.; Wilner, David J.; Zhang, Ke "Molecules with ALMA at Planet-forming Scales (MAPS). I. Program Overview and Highlights" *The Astrophysical Journal Supplement Series*, 257 :1, 2021.
- Obonyo, W. O.; Lumsden, S. L.; Hoare, M. G.; Kurtz, S. E.; Purser, S. J. D. "A multi-epoch study of radio continuum emission from massive protostars" *Monthly Notices of the Royal Astronomical Society*, 501 :5197, 2021.
- Ocker, Stella Koch; Cordes, James M.; Chatterjee, Shami; Dolch, Timothy "An In Situ Study of Turbulence near Stellar Bow Shocks" *The Astrophysical Journal*, 922 :233, 2021.
- O'Connor, B.; Troja, E.; Dichiaro, S.; Chase, E. A.; Ryan, G.; Cenko, S. B.; Fryer, C. L.; Ricci, R.; Marshall, F.; Kouveliotou, C.; Wollaeger, R. T.; Fontes, C. J.; Korobkin, O.; Gatkine, P.; Kutyrev, A.; Veilleux, S.; Kawai, N.; Sakamoto, T. "A tale of two mergers: constraints on kilonova detection in two short GRBs at  $z \sim 0.5$ " *Monthly Notices of the Royal Astronomical Society*, 502 :1279, 2021.
- Ohashi, Satoshi; Kobayashi, Hiroshi; Nakatani, Riouhei; Okuzumi, Satoshi; Tanaka, Hidekazu; Murakawa, Koji; Zhang, Yichen; Liu, Haoyu Baobab; Sakai, Nami "Ring Formation by Coagulation of Dust Aggregates in the Early Phase of Disk Evolution around a Protostar" *The Astrophysical Journal*, 907 :80, 2021.
- Okabe, Nobuhiro; Dicker, Simon; Eckert, Dominique; Mroczkowski, Tony; Gastaldello, Fabio; Lin, Yen-Ting; Devlin, Mark; Romero, Charles E.; Birkinshaw, Mark; Sarazin, Craig; Horellou, Cathy; Kitayama, Tetsu; Umetsu, Keiichi; Sereno, Mauro; Mason, Brian S.; Zuhone, John A.; Honda, Ayaka; Akamatsu, Hiroki; Chiu, I. -Non; Kohno, Kotaro; Lin, Kai-Yang; Medezinski, Elinor; Miyazaki, Satoshi; Mitsuishi, Ikuyuki; Nishizawa, Atsushi J.; Oguri, Masamune; Ota, Naomi; Pacaud, Florian; Pierre, Marguerite; Sievers, Jonathan; Smolčić, Vernesa; Stanchfield, Sara; Tanaka, Keigo; Yamamoto, Ryoichi; Yang, Chong; Yoshida, Atsushi "Active gas features in three HSC-SSP CAMIRA clusters revealed by high angular resolution analysis of MUSTANG-2 SZE and XXL X-ray observations" *Monthly Notices of the Royal Astronomical Society*, 501



- :1701, 2021.
- Okoda, Yuki; Oya, Yoko; Abe, Shotaro; Komaki, Ayano; Watanabe, Yoshimasa; Yamamoto, Satoshi "Molecular Distributions of the Disk/Envelope System of L483: Principal Component Analysis for the Image Cube Data" *The Astrophysical Journal*, 923 :168, 2021.
- Okoda, Yuki; Oya, Yoko; Francis, Logan; Johnstone, Doug; Inutsuka, Shu-Ichiro; Ceccarelli, Cecilia; Codella, Claudio; Chandler, Claire; Sakai, Nami; Aikawa, Yuri; Alves, Felipe O.; Balucani, Nadia; Bianchi, Eleonora; Bouvier, Mathilde; Caselli, Paola; Caux, Emmanuel; Charnley, Steven; Choudhury, Spandan; De Simone, Marta; Dulieu, Francois; Durán, Aurora; Evans, Lucy; Favre, Cécile; Fedele, Davide; Feng, Siyi; Fontani, Francesco; Hama, Tetsuya; Hanawa, Tomoyuki; Herbst, Eric; Hirota, Tomoya; Imai, Muneaki; Isella, Andrea; Jiménez-Serra, Izaskun; Kahane, Claudine; Lefloch, Bertrand; Loinard, Laurent; López-Sepulcre, Ana; Maud, Luke T.; Maureira, María José; Menard, Francois; Mercimek, Seyma; Miotello, Anna; Moellenbrock, George; Mori, Shoji; Murillo, Nadia M.; Nakatani, Riouhei; Nomura, Hideko; Oba, Yasuhiro; O'Donoghue, Ross; Ohashi, Satoshi; Ospina-Zamudio, Juan; Pineda, Jaime E.; Podio, Linda; Rimola, Albert; Sakai, Takeshi; Segura-Cox, Dominique; Shirley, Yancy; Svoboda, Brian; Taquet, Vianney; Testi, Leonardo; Vastel, Charlotte; Viti, Serena; Watanabe, Naoki; Watanabe, Yoshimasa; Witzel, Arezu; Xue, Ci; Zhang, Yichen; Zhao, Bo; Yamamoto, Satoshi "FAUST. II. Discovery of a Secondary Outflow in IRAS 15398-3359: Variability in Outflow Direction during the Earliest Stage of Star Formation?" *The Astrophysical Journal*, 910 :11, 2021.
- Okon, Hiromichi; Tanaka, Takaaki; Uchida, Hiroyuki; Tsuru, Takeshi Go; Seta, Masumichi; Kokusho, Takuma; Smith, Randall K. "Investigation of the Physical Origin of Overionized Recombining Plasma in the Supernova Remnant IC 443 with XMM-Newton" *The Astrophysical Journal*, 921 :99, 2021.
- Oguin, Fernando A.; Sanhueza, Patricio; Guzmán, Andrés E.; Lu, Xing; Saigo, Kazuya; Zhang, Qizhou; Silva, Andrea; Chen, Huei-Ru Vivien; Li, Shanghuo; Ohashi, Satoshi; Nakamura, Fumitaka; Sakai, Takeshi; Wu, Benjamin "Digging into the Interior of Hot Cores with ALMA (DIHCA). I. Dissecting the High-mass Star-forming Core G335.579-0.292 MM" *The Astrophysical Journal*, 909 :199, 2021.
- Olofsson, H.; Black, J. H.; Khouri, T.; Vlemmings, W. H. T.; Humphreys, E. M. L.; Lindqvist, M.; Maercker, M.; Nyman, L.; Ramstedt, S.; Tafaya, D. "Heavy-element Rydberg transition line emission from the post-giant-evolution star HD 101584" *Astronomy and Astrophysics*, 651 :A35, 2021.
- O'Neill, Theo J.; Cosentino, Giuliana; Tan, Jonathan C.; Cheng, Yu; Liu, Mengyao "The Core Mass Function across Galactic Environments. III. Massive Protoclusters" *The Astrophysical Journal*, 916 :45, 2021.
- Orłowski-Scherer, John; Di Mascolo, Luca; Bhandarkar, Tanay; Manduca, Alex; Mroczkowski, Tony; Amodeo, Stefania; Battaglia, Nick; Brodwin, Mark; Choi, Steve K.; Devlin, Mark; Dicker, Simon; Dunkley, Jo; Gonzalez, Anthony H.; Han, Dongwon; Hilton, Matt; Huppenberger, Kevin; Hughes, John P.; Macinnis, Amanda; Knowles, Kenda; Koopman, Brian J.; Lowe, Ian; Moodley, Kavilan; Nati, Federico; Niemack, Michael D.; Page, Lyman A.; Partridge, Bruce; Romero, Charles; Salatino, Maria; Schillaci, Alessandro; Sehgal, Neelima; Sifón, Cristóbal; Staggs, Suzanne; Stanford, Spencer A.; Thornton, Robert; Vavagiakis, Eve M.; Wollack, Edward J.; Xu, Zhilei; Zhu, Ningfeng "Atacama Cosmology Telescope measurements of a large sample of candidates from the Massive and Distant Clusters of WISE Survey. Sunyaev-Zeldovich effect confirmation of MaDCoWS candidates using ACT" *Astronomy and Astrophysics*, 653 :A135, 2021.
- Ortiz-León, Gisela N.; Menten, Karl M.; Brunthaler, Andreas; Csengeri, Timea; Urquhart, James S.; Wyrowski, Friedrich; Gong, Yan; Rugel, Michael R.; Dzib, Sergio A.; Yang, Aiyuan; Nguyen, Hans; Cotton, William D.; Medina, Sac Nicté X.; Dokara, Rohit; König, Carsten; Beuther, Henrik; Pandian, Jagadheep D.; Reich, Wolfgang; Roy, Nirupam "A global view on star formation: the GLOSTAR Galactic plane survey. III. 6.7 GHz methanol maser survey in Cygnus X" *Astronomy and Astrophysics*, 651 :A87, 2021.
- Ortiz-León, Gisela N.; Plunkett, Adele L.; Loinard, Laurent; Dzib, Sergio A.; Rodríguez-Garza, Carolina B.; Pillai, Thushara; Gong, Yan; Brunthaler, Andreas "Discovery of 22 GHz Water Masers in the Serpens South Region" *The Astronomical Journal*, 162 :68, 2021.
- O'Sullivan, Ewan; Kunert-Bajraszewska, Magdalena; Siemiginowska, Aneta; Burke, D. J.; Combes, Françoise; Salomé, Philippe; Giacintucci, Simona "The Cluster-central Compact Steep-spectrum Radio Galaxy 1321+045" *The Astrophysical Journal*, 913 :105, 2021.
- Otter, Justin; Ginsburg, Adam; Ballering, Nicholas P.; Bally, John; Eisner, J. A.; Goddi, Ciriaco; Plambeck, Richard; Wright, Melvyn "Small Protoplanetary Disks in the Orion Nebula Cluster and OMC1 with ALMA" *The Astrophysical Journal*, 923 :221, 2021.
- Oya, Yoko; Watanabe, Yoshimasa; López-Sepulcre, Ana; Ceccarelli, Cecilia; Lefloch, Bertrand; Favre, Cécile; Yamamoto, Satoshi "Rotating Motion of the Outflow of IRAS 16293-2422 A1 at Its Origin Point Near the Protostar" *The Astrophysical Journal*, 921 :12, 2021.
- Pace, Zachary J.; Tremonti, Christy; Schaefer, Adam L.; Stark, David V.; Witherspoon, Catherine A.; Masters, Karen L.; Drory, Nir; Zhang, Kai "SDSS-IV/MaNGA: Can Impulsive Gaseous Inflows Explain Steep Oxygen Abundance Profiles and Anomalously Low-Metallicity Regions?" *The Astrophysical Journal*, 908 :165, 2021.
- Padave, Mansi; Borthakur, Sanchayeeta; Gim, Hansung B.; Jansen, Rolf A.; Thilker, David; Heckman, Timothy; Kennicutt, Robert C.; Momjian, Emmanuel; Fox, Andrew J. "DIISC-II: Unveiling the Connections between Star Formation and Interstellar Medium in the Extended Ultraviolet Disk of NGC 3344" *The Astrophysical Journal*, 923 :199, 2021.
- Paduano, Alessandro; Bahramian, Arash; Miller-Jones, James C. A.; Kawka, Adela; Strader, Jay; Chomiuk, Laura; Heinke, Craig O.; Maccarone, Thomas J.; Britt, Christopher T.; Plotkin, Richard M.; Shaw, Arran W.; Shishkovsky, Laura; Tremou, Evangelia; Tudor, Vlad; Sivakoff, Gregory R. "The MAVERIC Survey: Simultaneous Chandra and VLA observations of the transitional millisecond pulsar candidate NGC 6652B" *Monthly Notices of the Royal Astronomical Society*, 506 :4107, 2021.
- Palliyaguru, N. T.; Corsi, A.; Pérez-Torres, M.; Varenius, E.; Van Eerten, H. "VLBI Observations of Supernova PTF11qj: Direct Constraints on the Size of the Radio Ejecta" *The Astrophysical Journal*, 910 :16, 2021.
- Palliyaguru, Nipuni T.; Agarwal, Devansh; Golpayegani, Golnoosh; Lynch, Ryan; Lorimer, Duncan R.; Nguyen, Benjamin; Corsi, Alessandra; Burke-Spolaor, Sarah "A targeted search for repeating fast radio bursts associated with gamma-ray bursts" *Monthly Notices of the Royal Astronomical Society*, 501 :541, 2021.
- Pan, Tong; Yu, Heng; Van Weeren, Reinout J.; Jia, Shumei; Li, Chengkui; Lyu, Yipeng "Catalog of One-side Head-Tail Galaxies in the FIRST Survey" *The Astrophysical Journal Supplement Series*, 254 :30, 2021.
- Pan, Zhichen; Ma, Xiao-Yun; Qian, Lei; Wang, Lin; Yan, Zhen; Luo, Jin-Tao; Ransom, Scott M.; Lorimer, Duncan R.; Jiang, Peng "Three pulsars discovered by FAST in the globular cluster NGC 6517 with a pulsar candidate sifting code based on dispersion measure to signal-to-noise ratio plots" *Research in Astronomy and Astrophysics*, 21 :143, 2021.
- Pan, Zhichen; Qian, Lei; Ma, Xiaoyun; Liu, Kuo; Wang, Lin; Luo, Jintao; Yan, Zhen; Ransom, Scott; Lorimer, Duncan; Li, Di; Jiang, Peng "FAST Globular Cluster Pulsar Survey: Twenty-four Pulsars Discovered in 15 Globular Clusters" *The Astrophysical Journal*, 915 :L28, 2021.
- Pandey, Arun Kumar "Gravitational waves in neutrino plasma and NANOGrav signal" *European Physical Journal C*, 81 :399, 2021.
- Paneque-Carreño, T.; Pérez, L. M.; Benisty, M.; Hall, C.; Veronesi, B.; Lodato, G.; Sierra, A.; Carpenter, J. M.; Andrews, S. M.; Bae, Jaehan; Henning, Th.; Kwon, W.; Linz, H.; Loinard, L.; Pinte, C.; Ricci, L.; Tazzari, M.; Testi, L.; Wilner, D. "Spiral Arms and a Massive Dust Disk with Non-Keplerian Kinematics: Possible Evidence for Gravitational Instability in the Disk of Elias 227" *The Astrophysical Journal*, 914 :88, 2021.
- Panić, O.; Haworth, T. J.; Petr-Gotzens, M. G.; Miley, J.; Van Den Ancker,

## APPENDIX A: PUBLICATIONS

- M.; Vioque, M.; Siess, L.; Parker, R.; Clarke, C. J.; Kamp, I.; Kennedy, G.; Oudmijer, R. D.; Pascucci, I.; Richards, A. M. S.; Ratzka, T.; Qi, C. "Planet formation in intermediate-separation binary systems" *Monthly Notices of the Royal Astronomical Society*, 501:4317, 2021.
- Pantoni, L.; Lapi, A.; Massardi, M.; Donevski, D.; Bressan, A.; Silva, L.; Pozzi, F.; Vignali, C.; Talia, M.; Cimatti, A.; Ronconi, T.; Danese, L. "Unveiling the nature of 11 dusty star-forming galaxies at the peak of cosmic star formation history" *Monthly Notices of the Royal Astronomical Society*, 504:928, 2021.
- Pantoni, L.; Massardi, M.; Lapi, A.; Donevski, D.; D'Amato, Q.; Giulietti, M.; Pozzi, F.; Talia, M.; Vignali, C.; Cimatti, A.; Silva, L.; Bressan, A.; Ronconi, T. "An ALMA view of 11 dusty star-forming galaxies at the peak of cosmic star formation history" *Monthly Notices of the Royal Astronomical Society*, 507:3998, 2021.
- Panurach, Teresa; Strader, Jay; Bahramian, Arash; Chomiuk, Laura; Miller-Jones, James C. A.; Heinke, Craig O.; Maccarone, Thomas J.; Shishkovsky, Laura; Sivakoff, Gregory R.; Tremou, Evangelia; Tudor, Vlad; Urquhart, Ryan "The MAVERIC Survey: Variable Jet-accretion Coupling in Luminous Accreting Neutron Stars in Galactic Globular Clusters" *The Astrophysical Journal*, 923:88, 2021.
- Paraschos, G. F.; Kim, J.-Y.; Krichbaum, T. P.; Zensus, J. A. "Pinpointing the jet apex of 3C 84" *Astronomy and Astrophysics*, 650:L18, 2021.
- Park, Jongho; Asada, Keiichi; Nakamura, Masanori; Kino, Motoki; Pu, Hung-Yi; Hada, Kazuhiro; Kravchenko, Evgeniya V.; Giroletti, Marcello "A Revised View of the Linear Polarization in the Subparsec Core of M87 at 7 mm" *The Astrophysical Journal*, 922:180, 2021.
- Park, Jongho; Hada, Kazuhiro; Nakamura, Masanori; Asada, Keiichi; Zhao, Guangyao; Kino, Motoki "Jet Collimation and Acceleration in the Giant Radio Galaxy NGC 315" *The Astrophysical Journal*, 909:76, 2021.
- Parks, Maxwell C.; Nixon, Conor A.; Villanueva, Geronimo L.; Smith, Michael D.; Khayat, Alain S. J.; Thelen, Alexander E.; Villard, Eric; Charnley, Steven B.; Irwin, Patrick G. J. "Observations of Mars with ALMA: potential for future constraints of global circulation models" *Journal of Astronomical Telescopes, Instruments, and Systems*, 7:25001, 2021.
- Paron, S.; Ortega, M. E.; Marinelli, A.; Areal, M. B.; Martinez, N. C. "Cyano radical emission at small spatial scales towards massive protostars" *Astronomy and Astrophysics*, 653:A77, 2021.
- Parthasarathy, A.; Bailes, M.; Shannon, R. M.; Van Straten, W.; Ostrowski, S.; Johnston, S.; Spiewak, R.; Reardon, D. J.; Kramer, M.; Krishnan, V. Venkatraman; Pennucci, T. T.; Abbate, F.; Buchner, S.; Camilo, F.; Champion, D. J.; Geyer, M.; Hugo, B.; Karastergiou, A. Jameson A.; Keith, M. J.; Serylak, M. "Measurements of pulse jitter and single-pulse variability in millisecond pulsars using MeerKAT" *Monthly Notices of the Royal Astronomical Society*, 502:407, 2021.
- Pasetto, Alice; Carrasco-González, Carlos; Gómez, José L.; Martí, José-Maria; Perucho, Manel; O'Sullivan, Shane P.; Anderson, Craig; Díaz-González, Daniel Jacobo; Fuentes, Antonio; Wardle, John "Reading M87's DNA: A Double Helix Revealing a Large-scale Helical Magnetic Field" *The Astrophysical Journal*, 923:L5, 2021.
- Pasini, T.; Gitti, M.; Brighenti, F.; O'Sullivan, E.; Gastaldello, F.; Temi, P.; Hamer, S. L. "A First Chandra View of the Cool Core Cluster A1668: Offset Cooling and AGN Feedback Cycle" *The Astrophysical Journal*, 911:66, 2021.
- Pattle, Kate; Lai, Shih-Ping; Wright, Melvyn; Coudé, Simon; Plambeck, Richard; Hoang, Thiem; Tang, Ya-Wen; Bastien, Pierre; Eswaraiiah, Chakali; Furuya, Ray S.; Hwang, Jihye; Inutsuka, Shu-Ichiro; Kim, Kee-Tae; Kirchschrager, Florian; Kwon, Woojin; Lee, Chang Won; Liu, Sheng-Yuan; Lyo, Aran; Ohashi, Nagayoshi; Rawlings, Mark G.; Tahani, Mehrnoosh; Tamura, Motohide; Soam, Archana; Wang, Jia-Wei; Ward-Thompson, Derek "OMC-1 dust polarization in ALMA Band 7: diagnosing grain alignment mechanisms in the vicinity of Orion Source I" *Monthly Notices of the Royal Astronomical Society*, 503:3414, 2021.
- Pawellek, Nicole; Wyatt, Mark; Matrà, Luca; Kennedy, Grant; Yelverton, Ben "A 75 per cent occurrence rate of debris discs around F stars in the  $\beta$  Pic moving group" *Monthly Notices of the Royal Astronomical Society*, 502:5390, 2021.
- Pegues, Jamila; Czekala, Ian; Andrews, Sean M.; Öberg, Karin I.; Herczeg, Gregory J.; Bergner, Jennifer B.; Ilseidore Cleeves, L.; Guzmán, Viviana V.; Huang, Jane; Long, Feng; Teague, Richard; Wilner, David J. "Dynamical Masses and Stellar Evolutionary Model Predictions of M Stars" *The Astrophysical Journal*, 908:42, 2021.
- Pegues, Jamila; Öberg, Karin I.; Bergner, Jennifer B.; Huang, Jane; Pascucci, Ilaria; Teague, Richard; Andrews, Sean M.; Bergin, Edwin A.; Cleeves, L. Ilseidore; Guzmán, Viviana V.; Long, Feng; Qi, Chunhua; Wilner, David J. "An Atacama Large Millimeter/submillimeter Array Survey of Chemistry in Disks around M4-M5 Stars" *The Astrophysical Journal*, 911:150, 2021.
- Pennock, Clara M.; Van Loon, Jacco Th; Filipović, Miroslav D.; Andernach, Heinz; Haberl, Frank; Kothes, Roland; Lenc, Emil; Rudnick, Lawrence; White, Sarah V.; Agliozzo, Claudia; Antón, Sonia; Bojčić, Ivan; Bomans, Dominik J.; Collier, Jordan D.; Crawford, Evan J.; Hopkins, Andrew M.; Jeganathan, Kanapathippillai; Kavanagh, Patrick J.; Koribalski, Bärbel S.; Leahy, Denis; Maggi, Pierre; Maitra, Chandreyee; Marvil, Josh; Michałowski, Michał J.; Norris, Ray P.; Oliveira, Joana M.; Payne, Jeffrey L.; Sano, Hidetoshi; Sasaki, Manami; Staveley-Smith, Lister; Vardoulakis, Eleni "The ASKAP-EMU Early Science Project: 888 MHz radio continuum survey of the Large Magellanic Cloud" *Monthly Notices of the Royal Astronomical Society*, 506:3540, 2021.
- Pensabene, A.; Decarli, R.; Bañados, E.; Venemans, B.; Walter, F.; Bertoldi, F.; Fan, X.; Farina, E. P.; Li, J.; Mazzucchelli, C.; Novak, M.; Riechers, D.; Rix, H.-W.; Strauss, M. A.; Wang, R.; Weiß, A.; Yang, J.; Yang, Y. "ALMA multiline survey of the ISM in two quasar host-companion galaxy pairs at  $z > 6$ " *Astronomy and Astrophysics*, 652:A66, 2021.
- Pereira-Santaella, M.; Colina, L.; García-Burillo, S.; Lamperti, I.; González-Alfonso, E.; Perna, M.; Arribas, S.; Alonso-Herrero, A.; Aalto, S.; Combes, F.; Labiano, A.; Piqueras-López, J.; Rigopoulou, D.; Van Der Werf, P. "Physics of ULIRGs with MUSE and ALMA: The PUMA project. II. Are local ULIRGs powered by AGN? The subkiloparsec view of the 220 GHz continuum" *Astronomy and Astrophysics*, 651:A42, 2021.
- Perger, Krisztina; Frey, Sándor; Schwartz, Daniel A.; Gabányi, Krisztina É.; Gurvits, Leonid I.; Paragi, Zolt "Multi-scale Radio and X-Ray Structure of the High-redshift Quasar PMN J0909+0354" *The Astrophysical Journal*, 915:98, 2021.
- Perrott, Yvette C.; López-Cañiego, Marcos; Génova-Santos, Ricardo T.; Rubiño-Martín, Jose Alberto; Ashdown, Mark; Herranz, Diego; Lähteenmäki, Anne; Lasenby, Anthony N.; López-Caraballo, Carlos H.; Poidevin, Frédéric; Tornikoski, Merja "28-40 GHz variability and polarimetry of bright compact sources in the QUIJOTE cosmological fields" *Monthly Notices of the Royal Astronomical Society*, 502:4779, 2021.
- Pesce, Dominic W. "A D-term Modeling Code (DMC) for Simultaneous Calibration and Full-Stokes Imaging of Very Long Baseline Interferometric Data" *The Astronomical Journal*, 161:178, 2021.
- Pesce, Dominic W.; Seth, Anil C.; Greene, Jenny E.; Braatz, James A.; Condon, James J.; Kent, Brian R.; Krajnović, Davor "A Restless Supermassive Black Hole in the Galaxy J0437+2456" *The Astrophysical Journal*, 909:141, 2021.
- Pessa, I.; Schinnerer, E.; Belfiore, F.; Emsellem, E.; Leroy, A. K.; Schrubba, A.; Kruijssen, J. M. D.; Pan, H.-A.; Blanc, G. A.; Sanchez-Blazquez, P.; Bigiel, F.; Chevance, M.; Congiu, E.; Dale, D.; Faesi, C. M.; Glover, S. C. O.; Grasha, K.; Groves, B.; Ho, I.; Jiménez-Donaire, M.; Klessen, R.; Kreckel, K.; Koch, E. W.; Liu, D.; Meidt, S.; Pety, J.; Querejeta, M.; Rosolowsky, E.; Saito, T.; Santoro, F.; Sun, J.; Usero, A.; Watkins, E. J.; Williams, T. G. "Star formation scaling relations at 100 pc from PHANGS: Impact of completeness and spatial scale" *Astronomy and Astrophysics*, 650:A134, 2021.
- Petriella, A.; Duvidovich, L.; Giacani, E. "Radio study of HESS J1857+026: Gamma-rays from a superbubble?" *Astronomy and Astrophysics*, 652:A142, 2021.

- Petriella, A.; Duvidovich, L.; Giacani, E. "Estudio en radio de dos fuentes de muy alta energía" *Boletín de la Asociación Argentina de Astronomía La Plata Argentina*, 62 :134, 2021.
- Petrov, Leonid "The Wide-field VLBA Calibrator Survey: WFC3" *The Astronomical Journal*, 161 :14, 2021.
- Phiri, S. P.; Kirk, J. M.; Ward-Thompson, D.; Sansom, A. E.; Bendo, G. J. "ALMA 13CO(J = 1-0) observations of NGC 604 in M33: physical properties of molecular clouds" *Monthly Notices of the Royal Astronomical Society*, 504 :4511, 2021.
- Pineda, Jaime E.; Schmiedeke, Anika; Caselli, Paola; Stahler, Steven W.; Frayer, David T.; Church, Sarah E.; Harris, Andrew I. "Neutral versus Ion Line Widths in Barnard 5: Evidence for Penetration by Magnetohydrodynamic Waves" *The Astrophysical Journal*, 912 :7, 2021.
- Pingel, N. M.; Pisano, D. J.; Ruzidana, M.; Burnett, M.; Rajwade, K. M.; Black, R.; Jeffs, B.; Warnick, K. F.; Lorimer, D. R.; Roshi, D. Anish; Prestage, R.; Mclaughlin, M. A.; Agarwal, D.; Chamberlin, T.; Hawkins, L.; Jensen, L.; Marganian, P.; Nelson, J. D.; Shillue, W.; Smith, E.; Simon, B.; Van Tonder, V.; White, S. "Commissioning the H I Observing Mode of the Beam Former for the Cryogenically Cooled Focal L-band Array for the GBT (FLAG)" *The Astronomical Journal*, 161 :163, 2021.
- Pinilla, P.; Kurtovic, N. T.; Benisty, M.; Manara, C. F.; Natta, A.; Sanchis, E.; Tazzari, M.; Stammer, S. M.; Ricci, L.; Testi, L. "A bright inner disk and structures in the transition disk around the very low-mass star CIDA 1" *Astronomy and Astrophysics*, 649 :A122, 2021.
- Piro, L.; Bruni, G.; Troja, E.; O'Connor, B.; Panessa, F.; Ricci, R.; Zhang, B.; Burgay, M.; Dichiaro, S.; Lee, K. J.; Lotti, S.; Niu, J. R.; Pilia, M.; Possenti, A.; Trudu, M.; Xu, H.; Zhu, W. W.; Kutyrev, A. S.; Veilleux, S. "The fast radio burst FRB 20201124A in a star-forming region: Constraints to the progenitor and multiwavelength counterparts" *Astronomy and Astrophysics*, 656 :L15, 2021.
- Plavin, A. V.; Kovalev, Y. Y.; Kovalev, Yu. A.; Troitsky, S. V. "Directional Association of TeV to PeV Astrophysical Neutrinos with Radio Blazars" *The Astrophysical Journal*, 908 :157, 2021.
- Pleunis, Ziggy; Good, Deborah C.; Kaspi, Victoria M.; Mckinven, Ryan; Ransom, Scott M.; Scholz, Paul; Bandura, Kevin; Bhardwaj, Mohit; Boyle, P. J.; Brar, Charanjot; Cassanelli, Tomas; Chawla, Pragma; (Adam) Dong, Fengqiu; Fonseca, Emmanuel; Gaensler, B. M.; Josephy, Alexander; Kaczmarek, Jane F.; Leung, Calvin; Lin, Hsiu-Hsien; Masui, Kiyoshi W.; Mena-Parra, Juan; Michilli, Daniele; Ng, Cherry; Patel, Chitrag; Rafiei-Ravandi, Masoud; Rahman, Mubdi; Sanghavi, Pranav; Shin, Kaitlyn; Smith, Kendrick M.; Stairs, Ingrid H.; Tendulkar, Shriharsh P. "Fast Radio Burst Morphology in the First CHIME/FRB Catalog" *The Astrophysical Journal*, 923 :1, 2021.
- Pol, Nihan S.; Taylor, Stephen R.; Kelley, Luke Zoltan; Vigeland, Sarah J.; Simon, Joseph; Chen, Siyuan; Arzoumanian, Zaven; Baker, Paul T.; Bécsy, Bence; Brazier, Adam; Brook, Paul R.; Burke-Spolaor, Sarah; Chatterjee, Shami; Cordes, James M.; Cornish, Neil J.; Crawford, Fronefield; Thankful Cromartie, H.; Decesar, Megan E.; Demorest, Paul B.; Dolch, Timothy; Ferrara, Elizabeth C.; Fiore, William; Fonseca, Emmanuel; Garver-Daniels, Nathan; Good, Deborah C.; Hazboun, Jeffrey S.; Jennings, Ross J.; Jones, Megan L.; Kaiser, Andrew R.; Kaplan, David L.; Shapiro Key, Joey; Lam, Michael T.; Lazio, T. Joseph W.; Luo, Jing; Lynch, Ryan S.; Madison, Dustin R.; McEwen, Alexander; Mclaughlin, Maura A.; Mingarelli, Chiara M. F.; Ng, Cherry; Nice, David J.; Pennucci, Timothy T.; Ransom, Scott M.; Ray, Paul S.; Shapiro-Albert, Brent J.; Siemens, Xavier; Stairs, Ingrid H.; Stinebring, Daniel R.; Swiggum, Joseph K.; Vallisneri, Michele; Wahl, Haley; Witt, Caitlin A.; Nanograv Collaboration "Astrophysics Milestones for Pulsar Timing Array Gravitational-wave Detection" *The Astrophysical Journal*, 911 :L34, 2021.
- Ponomareva, Anastasia A.; Mulaudzi, Wanga; Maddox, Natasha; Frank, Bradley S.; Jarvis, Matt J.; Di Teodoro, Enrico M.; Glowacki, Marcin; Kraan-Korteweg, Renée C.; Oosterloo, Tom A.; Adams, Elizabeth A. K.; Pan, Hengxing; Prandoni, Isabella; Rajhanson, Sambatriniaina H. A.; Sinigaglia, Francesco; Adams, Nathan J.; Heywood, Ian; Bowler, Rebecca A. A.; Hatfield, Peter W.; Collier, Jordan D.; Sekhar, Srikrishna "MIGHTEE-HI: The baryonic Tully-Fisher relation over the last billion years" *Monthly Notices of the Royal Astronomical Society*, 508 :pp.1195-1205, 2021.
- Popkov, A. V.; Kovalev, Y. Y.; Petrov, L. Y.; Kovalev, Yu. A. "Parsec-scale Properties of Steep- and Flat-spectrum Extragalactic Radio Sources from a VLBA Survey of a Complete North Polar Cap Sample" *The Astronomical Journal*, 161 :88, 2021.
- Popov, M. V.; Bartel, N.; Burgin, M. S.; Smirnova, T. V.; Soglasnov, V. A. "Ionospheric effects in VLBI measured with space-ground interferometer RadioAstron" *Monthly Notices of the Royal Astronomical Society*, 506 :4101, 2021.
- Popov, M. V.; Smirnova, T. V. "The Spectrum Power of Interstellar Plasma Inhomogeneities in the Direction of Eleven Radio Pulsars" *Astronomy Reports*, 65 :1129, 2021.
- Pötzi, F. M.; Lobanov, A. P.; Ros, E.; Gómez, J. L.; Bruni, G.; Bach, U.; Fuentes, A.; Gurvits, L. I.; Jauncey, D. L.; Kovalev, Y. Y.; Kravchenko, E. V.; Lisakov, M. M.; Savolainen, T.; Sokolovsky, K. V.; Zensus, J. A. "Probing the innermost regions of AGN jets and their magnetic fields with RadioAstron. IV. The quasar 3C 345 at 18 cm: Magnetic field structure and brightness temperature" *Astronomy and Astrophysics*, 648 :A82, 2021.
- Powell, Devon; Vegetti, Simona; Mckean, John P.; Spingola, Cristiana; Rizzo, Francesca; Stacey, Hannah R. "A novel approach to visibility-space modelling of interferometric gravitational lens observations at high angular resolution" *Monthly Notices of the Royal Astronomical Society*, 501 :515, 2021.
- Pozzi, F.; Calura, F.; Fudamoto, Y.; Dessauges-Zavadsky, M.; Gruppioni, C.; Talia, M.; Zamorani, G.; Bethermin, M.; Cimatti, A.; Enia, A.; Khusanova, Y.; Decarli, R.; Le Fèvre, O.; Capak, P.; Cassata, P.; Faisst, A. L.; Yan, L.; Schaerer, D.; Silverman, J.; Bardelli, S.; Boquien, M.; Enia, A.; Narayanan, D.; Ginolfi, M.; Hathi, N. P.; Jones, G. C.; Koekemoer, A. M.; Lemaux, B. C.; Loiacono, F.; Maiolino, R.; Riechers, D. A.; Rodighiero, G.; Romano, M.; Vallini, L.; Vergani, D.; Zucca, E. "The ALPINE-ALMA [CII] survey. Dust mass budget in the early Universe" *Astronomy and Astrophysics*, 653 :A84, 2021.
- Prieto, Joaquin; Escala, Andrés; Privon, George C.; D'Etigny, Juan "Black hole fuelling in galaxy mergers: a high-resolution analysis" *Monthly Notices of the Royal Astronomical Society*, 508 :3672, 2021.
- Pritchard, Joshua; Murphy, Tara; Zic, Andrew; Lynch, Christine; Heald, George; Kaplan, David L.; Anderson, Craig; Banfield, Julie; Hale, Catherine; Hotan, Aidan; Lenc, Emil; Leung, James K.; McConnell, David; Moss, Vanessa A.; Raja, Wasim; Stewart, Adam J.; Whiting, Matthew "A circular polarisation survey for radio stars with the Australian SKA Pathfinder" *Monthly Notices of the Royal Astronomical Society*, 502 :5438, 2021.
- Puente, Víctor "A priori zenith wet delays in the analysis of VLBI CONT sessions" *Advances in Space Research*, 67 :2359, 2021.
- Puente, Víctor; Azcue, Esther; Gomez-Espada, Yaiza; Garcia-Espada, Susana "Comparison of common VLBI and GNSS estimates in CONT17 campaign" *Journal of Geodesy*, 95 :120, 2021.
- Puglisi, Annagrazia; Daddi, Emanuele; Brusa, Marcella; Bournaud, Frederic; Fensch, Jeremy; Liu, Daizhong; Delvecchio, Ivan; Calabrò, Antonello; Circosta, Chiara; Valentino, Francesco; Perna, Michele; Jin, Shuowen; Enia, Andrea; Mancini, Chiara; Rodighiero, Giulia "A titanic interstellar medium ejection from a massive starburst galaxy at redshift 1.4" *Nature Astronomy*, 2101 :, 2021.
- Puglisi, Annagrazia; Daddi, Emanuele; Valentino, Francesco; Magdis, Georgios; Liu, Daizhong; Kokorev, Vasily; Circosta, Chiara; Elbaz, David; Bournaud, Frederic; Gomez-Guijarro, Carlos; Jin, Shuowen; Madden, Suzanne; Sargent, Mark T.; Swinbank, Mark "Submillimetre compactness as a critical dimension to understand the main sequence of star-forming galaxies" *Monthly Notices of the Royal Astronomical*

## APPENDIX A: PUBLICATIONS

- Society, 508 :5217, 2021.
- Punsly, Brian "The Bulk Flow Velocity and Acceleration of the Inner Jet in M87" *The Astrophysical Journal*, 918 :4, 2021.
- Punsly, Brian; Chen, Sina "Did the Event Horizon Telescope Detect the Base of the Submilliarcsecond Tubular Jet in M87?" *The Astrophysical Journal*, 921 :L38, 2021.
- Punsly, Brian; Frey, Sándor; Reynolds, Cormac; Marziani, Paola; Pushkarev, Alexander; Chen, Sina; Li, Shang; Kharb, Preeti "The Highly Self-absorbed Blazar PKS 1351-018" *The Astrophysical Journal*, 919 :40, 2021.
- Punsly, Brian; Nagai, Hiroshi; Savolainen, Tuomas; Orienti, Monica "Observing the Time Evolution of the Multicomponent Nucleus of 3C 84" *The Astrophysical Journal*, 911 :19, 2021.
- Purser, S. J. D.; Lumsden, S. L.; Hoare, M. G.; Kurtz, S. "A Galactic survey of radio jets from massive protostars" *Monthly Notices of the Royal Astronomical Society*, 504 :338, 2021.
- Pyerin, Max Ackermann; Delage, Timmy N.; Kurtovic, Nicolás T.; Gárate, Matías; Henning, Thomas; Pinilla, Paola "Constraining the properties of the potential embedded planets in the disk around HD 100546" *Astronomy and Astrophysics*, 656 :A150, 2021.
- Quarles, Billy; Eggl, Siegfried; Rosario-Franco, Marialis; Li, Gongjie "Exomoons in Systems with a Strong Perturber: Applications to a Cen AB" *The Astronomical Journal*, 162 :58, 2021.
- Querejeta, M.; Lelli, F.; Schinnerer, E.; Colombo, D.; Lisenfeld, U.; Mundell, C. G.; Bigiel, F.; García-Burillo, S.; Herrera, C. N.; Hughes, A.; Kruijssen, J. M. D.; Meidt, S. E.; Moore, T. J. T.; Pety, J.; Rigby, A. J. "ALMA resolves giant molecular clouds in a tidal dwarf galaxy" *Astronomy and Astrophysics*, 645 :A97, 2021.
- Querejeta, M.; Schinnerer, E.; Meidt, S.; Sun, J.; Leroy, A. K.; Emsellem, E.; Klessen, R. S.; Muñoz-Mateos, J. C.; Salo, H.; Laurikainen, E.; Bešlić, I.; Blanc, G. A.; Chevance, M.; Dale, D. A.; Eibensteiner, C.; Faesi, C.; García-Rodríguez, A.; Glover, S. C. O.; Grasha, K.; Henshaw, J.; Herrera, C.; Hughes, A.; Kreckel, K.; Kruijssen, J. M. D.; Liu, D.; Murphy, E. J.; Pan, H.-A.; Pety, J.; Razza, A.; Rosolowsky, E.; Saito, T.; Schruha, A.; Usero, A.; Watkins, E. J.; Williams, T. G. "Stellar structures, molecular gas, and star formation across the PHANGS sample of nearby galaxies" *Astronomy and Astrophysics*, 656 :A133, 2021.
- Quici, Benjamin; Hurley-Walker, Natasha; Seymour, Nicholas; Turner, Ross J.; Shabala, Stanislav S.; Huynh, Minh; Andernach, H.; Kapińska, Anna D.; Collier, Jordan D.; Johnston-Hollitt, Melanie; White, Sarah V.; Prandoni, Isabella; Galvin, Timothy J.; Franzen, Thomas; Ishwara-Chandra, C. H.; Bellstedt, Sabine; Tingay, Steven J.; Gaensler, Bryan M.; O'Brien, Andrew; Rogers, Johnathan; Chow, Kate; Driver, Simon; Robotham, Aaron "Remnant radio galaxies discovered in a multi-frequency survey" *Publications of the Astronomical Society of Australia*, 38 :e008, 2021.
- Radcliffe, J. F.; Barthel, P. D.; Garrett, M. A.; Beswick, R. J.; Thomson, A. P.; Muxlow, T. W. B. "The radio emission from active galactic nuclei" *Astronomy and Astrophysics*, 649 :L9, 2021.
- Radcliffe, J. F.; Barthel, P. D.; Thomson, A. P.; Garrett, M. A.; Beswick, R. J.; Muxlow, T. W. B. "Nowhere to hide: Radio-faint AGN in the GOODS-N field. II. Multi-wavelength AGN selection techniques and host galaxy properties" *Astronomy and Astrophysics*, 649 :A27, 2021.
- Rajpurohit, K.; Brunetti, G.; Bonafede, A.; Van Weeren, R. J.; Botteon, A.; Vazza, F.; Hoeft, M.; Riseley, C. J.; Bonnassieux, E.; Brienza, M.; Forman, W. R.; Röttgering, H. J. A.; Rajpurohit, A. S.; Locatelli, N.; Shimwell, T. W.; Cassano, R.; Di Gennaro, G.; Brügger, M.; Wittor, D.; Drabant, A.; Ignesti, A. "Physical insights from the spectrum of the radio halo in MACS J0717.5+3745" *Astronomy and Astrophysics*, 646 :A135, 2021.
- Rajpurohit, K.; Vazza, F.; Van Weeren, R. J.; Hoeft, M.; Brienza, M.; Bonnassieux, E.; Riseley, C. J.; Brunetti, G.; Bonafede, A.; Brügger, M.; Forman, W. R.; Rajpurohit, A. S.; Röttgering, H. J. A.; Drabant, A.; Domínguez-Fernández, P.; Wittor, D.; Andrade-Santos, F. "Dissecting nonthermal emission in the complex multiple-merger galaxy cluster Abell 2744: Radio and X-ray analysis" *Astronomy and Astrophysics*, 654 :A41, 2021.
- Rajpurohit, K.; Wittor, D.; Van Weeren, R. J.; Vazza, F.; Hoeft, M.; Rudnick, L.; Locatelli, N.; Eilek, J.; Forman, W. R.; Bonafede, A.; Bonnassieux, E.; Riseley, C. J.; Brienza, M.; Brunetti, G.; Brügger, M.; Loi, F.; Rajpurohit, A. S.; Röttgering, H. J. A.; Botteon, A.; Clarke, T. E.; Drabant, A.; Domínguez-Fernández, P.; Di Gennaro, G.; Gastaldello, F. "Understanding the radio relic emission in the galaxy cluster MACS J0717.5+3745: Spectral analysis" *Astronomy and Astrophysics*, 646 :A56, 2021.
- Ramasawmy, J.; Geach, J. E.; Hardcastle, M. J.; Best, P. N.; Bonato, M.; Bondi, M.; Calistro Rivera, G.; Cochrane, R. K.; Conway, J. E.; Coppin, K.; Duncan, K. J.; Dunlop, J. S.; Franco, M.; García-Vergara, C.; Jarvis, M. J.; Kondapally, R.; Mccheyne, I.; Prandoni, I.; Röttgering, H. J. A.; Smith, D. J. B.; Tasse, C.; Wang, L. "Low-frequency radio spectra of submillimetre galaxies in the Lockman Hole" *Astronomy and Astrophysics*, 648 :A14, 2021.
- Ranasinghe, Sujith; Leahy, Denis; Stil, Jeroen "Search for and Identification of Young Compact Galactic Supernova Remnants Using THOR" *Universe*, 7 :338, 2021.
- Reardon, D. J.; Shannon, R. M.; Cameron, A. D.; Goncharov, B.; Hobbs, G. B.; Middleton, H.; Shamohammadi, M.; Thyagarajan, N.; Bailes, M.; Bhat, N. D. R.; Dai, S.; Kerr, M.; Manchester, R. N.; Russell, C. J.; Spiewak, R.; Wang, J. B.; Zhu, X. J. "The Parkes pulsar timing array second data release: timing analysis" *Monthly Notices of the Royal Astronomical Society*, 507 :2137, 2021.
- Rebolledo, David; Green, Anne J.; Burton, Michael G.; Breen, Shari L.; Garay, Guido "The Carina Nebula and Gum 31 Molecular Complex. III. The Distribution of the 1-3 GHz Radio Continuum across the Whole Nebula" *The Astrophysical Journal*, 909 :93, 2021.
- Redaelli, E.; Bovino, S.; Giannetti, A.; Sabatini, G.; Caselli, P.; Wyrowski, F.; Schleicher, D. R. G.; Colombo, D. "Identification of pre-stellar cores in high-mass star forming clumps via H2D+ observations with ALMA" *Astronomy and Astrophysics*, 650 :A202, 2021.
- Reddy, Karthik; Georganopoulos, Markos; Meyer, Eileen T. "X-Ray-to-radio Offset Inference from Low-count X-Ray Jets" *The Astrophysical Journal Supplement Series*, 253 :37, 2021.
- Regis, Marco; Reynoso-Cordova, Javier; Filipović, Miroslav D.; Brügger, Marcus; Carretti, Ettore; Collier, Jordan; Hopkins, Andrew M.; Lenc, Emil; Maio, Umberto; Marvil, Joshua R.; Norris, Ray P.; Vernstrom, Tessa "The EMU view of the Large Magellanic Cloud: troubles for sub-TeV WIMPs" *Journal of Cosmology and Astro-Particle Physics*, 2021 :46, 2021.
- Reiprich, T. H.; Veronica, A.; Pacaud, F.; Ramos-Ceja, M. E.; Ota, N.; Sanders, J.; Kara, M.; Erben, T.; Klein, M.; Erler, J.; Kerp, J.; Hoang, D. N.; Brügger, M.; Marvil, J.; Rudnick, L.; Biffi, V.; Dolag, K.; Aschersleben, J.; Basu, K.; Brunner, H.; Bulbul, E.; Dennerl, K.; Eckert, D.; Freyberg, M.; Gatuzz, E.; Ghirardini, V.; Käfer, F.; Merloni, A.; Migkas, K.; Nandra, K.; Predehl, P.; Robrade, J.; Salvato, M.; Whelan, B.; Diaz-Ocampo, A.; Hernandez-Lang, D.; Zenteno, A.; Brown, M. J. I.; Collier, J. D.; Diego, J. M.; Hopkins, A. M.; Kapinska, A.; Koribalski, B.; Mroczkowski, T.; Norris, R. P.; O'Brien, A.; Vardoulaki, E. "The Abell 3391/95 galaxy cluster system. A 15 Mpc intergalactic medium emission filament, a warm gas bridge, infalling matter clumps, and (re-) accelerated plasma discovered by combining SRG/eROSITA data with ASKAP/EMU and DECAM data" *Astronomy and Astrophysics*, 647 :A2, 2021.
- Ren, Zhiyuan; Zhu, Lei; Shi, Hui; Yue, Nannan; Li, Di; Zhang, Qizhou; Mardones, Diego; Wu, Jingwen; Jiao, Sihang; Liu, Shu; Luo, Gan; Xie, Jinjin; Zhang, Chao; Xu, Xuefang "Convergent filaments contracting towards an intermediate-mass pre-stellar core" *Monthly Notices of the Royal Astronomical Society*, 505 :5183, 2021.
- Reynolds, Nickolas K.; Tobin, John J.; Sheehan, Patrick; Sadavoy, Sarah I.; Kratter, Kaitlin M.; Li, Zhi-Yun; Chandler, Claire J.; Segura-Cox, Dominique; Looney, Leslie W.; Dunham, Michael M. "Kinematic Analysis of a Protostellar Multiple System: Measuring the Protostar Masses and

- Assessing Gravitational Instability in the Disks of L1448 IRS3B and L1448 IRS3A" *The Astrophysical Journal*, 907 :L10, 2021.
- Rho, J.; Jarrett, T. H.; Tram, L. N.; Lim, W.; Reach, W. T.; Bieging, J.; Lee, H.-G.; Koo, B.-C.; Whitney, B. "Shocked Molecular Hydrogen and Broad CO Lines from the Interacting Supernova Remnant HB 3" *The Astrophysical Journal*, 917 :47, 2021.
- Rhodes, Lauren; Fender, Rob; Williams, David R. A.; Mooley, Kunal "An early peak in the radio light curve of short-duration Gamma-Ray Burst 200826A" *Monthly Notices of the Royal Astronomical Society*, 503 :2966, 2021.
- Riaz, B.; Machida, M. N. "Complex structure of a proto-brown dwarf" *Monthly Notices of the Royal Astronomical Society*, 504 :6049, 2021.
- Ricci, C.; Privon, G. C.; Pfeifle, R. W.; Armus, L.; Iwasawa, K.; Torres-Albà, N.; Satyapal, S.; Bauer, F. E.; Treister, E.; Ho, L. C.; Aalto, S.; Arévalo, P.; Barcos-Muñoz, L.; Charmandaris, V.; Diaz-Santos, T.; Evans, A. S.; Gao, T.; Inami, H.; Koss, M. J.; Lansbury, G.; Linden, S. T.; Medling, A.; Sanders, D. B.; Song, Y.; Stern, D.; U, V.; Ueda, Y.; Yamada, S. "A hard X-ray view of luminous and ultra-luminous infrared galaxies in GOALS - I. AGN obscuration along the merger sequence" *Monthly Notices of the Royal Astronomical Society*, 506 :5935, 2021.
- Ricci, R.; Troja, E.; Bruni, G.; Matsumoto, T.; Piro, L.; O'Connor, B.; Piran, T.; Navaieelavasani, N.; Corsi, A.; Giacomazzo, B.; Wieringa, M. H. "Searching for the radio remnants of short-duration gamma-ray bursts" *Monthly Notices of the Royal Astronomical Society*, 500 :1708, 2021.
- Rich, Evan A.; Teague, Richard; Monnier, John D.; Davies, Claire L.; Bosman, Arthur; Harries, Tim J.; Calvet, Nuria; Adams, Fred C.; Wilner, David; Zhu, Zhaohuan "Investigating the Relative Gas and Small Dust Grain Surface Heights in Protoplanetary Disks" *The Astrophysical Journal*, 913 :138, 2021.
- Richard, C.; Jørgensen, J. K.; Margulès, L.; Motiyenko, R. A.; Guillemin, J.-C.; Groner, P. "Torsional-rotational spectrum of doubly deuterated dimethyl ether (CH<sub>3</sub>OCH<sub>2</sub>D). First ALMA detection in the interstellar medium" *Astronomy and Astrophysics*, 651 :A120, 2021.
- Richards, Gordon T.; McCaffrey, Trevor V.; Kimball, Amy; Rankine, Amy L.; Matthews, James H.; Hewett, Paul C.; Rivera, Angelica B. "Probing the Wind Component of Radio Emission in Luminous High-redshift Quasars" *The Astronomical Journal*, 162 :270, 2021.
- Rickett, Barney J.; Stinebring, Dan R.; Zhu, Hengrui; Minter, Anthony H. "Scintillation Arcs in Pulsar B0450-18" *The Astrophysical Journal*, 907 :49, 2021.
- Rico-Villas, F.; Martín-Pintado, J.; González-Alfonso, E.; Rivilla, V. M.; Martín, S.; García-Burillo, S.; Jiménez-Serra, I.; Sánchez-García, M. "Vibrationally excited HC<sub>3</sub>N emission in NGC 1068: tracing the recent star formation in the starburst ring" *Monthly Notices of the Royal Astronomical Society*, 502 :3021, 2021.
- Ridolfi, A.; Gautam, T.; Freire, P. C. C.; Ransom, S. M.; Buchner, S. J.; Possenti, A.; Krishnan, V. Venkatraman; Bailes, M.; Kramer, M.; Stappers, B. W.; Abbate, F.; Barr, E. D.; Burgay, M.; Camilo, F.; Corongiu, A.; Jameson, A.; Padmanabh, P. V.; Vleschow, L.; Champion, D. J.; Chen, W.; Geyer, M.; Karastergiou, A.; Karuppusamy, R.; Parthasarathy, A.; Reardon, D. J.; Serylak, M.; Shannon, R. M.; Spiewak, R. "Eight new millisecond pulsars from the first MeerKAT globular cluster census" *Monthly Notices of the Royal Astronomical Society*, 504 :1407, 2021.
- Riechers, Dominik A.; Cooray, Asantha; Pérez-Fournon, Ismael; Neri, Roberto "The GADOT Galaxy Survey: Dense Gas and Feedback in Herschel-selected Starburst Galaxies at Redshifts 2 to 6" *The Astrophysical Journal*, 913 :141, 2021.
- Riechers, Dominik A.; Nayyeri, Hooshang; Burgarella, Denis; Emonts, Bjorn H. C.; Clements, David L.; Cooray, Asantha; Ivison, Rob J.; Oliver, Seb; Pérez-Fournon, Ismael; Rigopoulou, Dimitra; Scott, Douglas "Rise of the Titans: Gas Excitation and Feedback in a Binary Hyperluminous Dusty Starburst Galaxy at z ~ 6" *The Astrophysical Journal*, 907 :62, 2021.
- Riggi, S.; Umana, G.; Triglilio, C.; Cavallaro, F.; Ingallinera, A.; Leto, P.; Bufano, F.; Norris, R. P.; Hopkins, A. M.; Filipović, M. D.; Andernach, H.; Van Loon, J. Th; Michałowski, M. J.; Bordiu, C.; An, T.; Buemi, C.; Carretti, E.; Collier, J. D.; Joseph, T.; Koribalski, B. S.; Kothes, R.; Loru, S.; McConnell, D.; Pommier, M.; Sciacca, E.; Schillirò, F.; Vitello, F.; Warhurst, K.; Whiting, M. "Evolutionary map of the Universe (EMU): Compact radio sources in the SCORPIO field towards the galactic plane" *Monthly Notices of the Royal Astronomical Society*, 502 :60, 2021.
- Riley, Thomas E.; Watts, Anna L.; Ray, Paul S.; Bogdanov, Slavko; Guillot, Sebastien; Morsink, Sharon M.; Bilous, Anna V.; Arzoumanian, Zaven; Choudhury, Devarshi; Deneva, Julia S.; Gendreau, Keith C.; Harding, Alice K.; Ho, Wynn C. G.; Lattimer, James M.; Loewenstein, Michael; Ludlam, Renee M.; Markwardt, Craig B.; Okajima, Takashi; Prescod-Weinstein, Chanda; Remillard, Ronald A.; Wolff, Michael T.; Fonseca, Emmanuel; Cromartie, H. Thankful; Kerr, Matthew; Pennucci, Timothy T.; Parthasarathy, Aditya; Ransom, Scott; Stairs, Ingrid; Guillemot, Lucas; Cognard, Ismael "A NICER View of the Massive Pulsar PSR J0740+6620 Informed by Radio Timing and XMM-Newton Spectroscopy" *The Astrophysical Journal*, 918 :L27, 2021.
- Roberts, O. J.; Veres, P.; Baring, M. G.; Briggs, M. S.; Kouveliotou, C.; Bissaldi, E.; Younes, G.; Chastain, S. I.; Delaunay, J. J.; Huppenkothen, D.; Tohuvavohu, A.; Bhat, P. N.; Göğüş, E.; Van Der Horst, A. J.; Kennea, J. A.; Kocevski, D.; Linford, J. D.; Guiric, S.; Hamburg, R.; Wilson-Hodge, C. A.; Burns, E. "Rapid spectral variability of a giant flare from a magnetar in NGC 253" *Nature*, 589 :207, 2021.
- Robinson, Justin H.; Bentz, Misty C.; Courtois, Hélène M.; Johnson, Megan C.; Crenshaw, D. M.; Meena, Beena; Polack, Garrett E.; Silverstein, Michele L.; Chen, Dading "Tully-Fisher Distances and Dynamical Mass Constraints for 24 Host Galaxies of Reverberation-mapped AGNs" *The Astrophysical Journal*, 912 :160, 2021.
- Rodi, J.; Tramacere, A.; Onori, F.; Bruni, G.; Sánchez-Fernández, C.; Focchi, M.; Natalucci, L.; Ubertini, P. "A Broadband View on Microquasar MAXI J1820+070 during the 2018 Outburst" *The Astrophysical Journal*, 910 :21, 2021.
- Rodríguez, Tatiana M.; Hofner, Peter; Araya, Esteban D.; Zhang, Qizhou; Linz, Hendrik; Kurtz, Stanley; Gomez, Laura; Carrasco-González, Carlos; Rosero, Viviana "Discovery of a Highly Collimated Flow from the High-mass Protostar ISOSS J23053+5953 SMM2" *The Astrophysical Journal*, 922 :66, 2021.
- Rodríguez-Baras, M.; Fuente, A.; Rivière-Marichalar, P.; Navarro-Almolda, D.; Caselli, P.; Gerin, M.; Kramer, C.; Roueff, E.; Wakelam, V.; Esplugues, G.; García-Burillo, S.; Le Gal, R.; Spezzano, S.; Alonso-Albi, T.; Bachiller, R.; Cazaux, S.; Commerçon, B.; Goicoechea, J. R.; Loison, J. C.; Treviño-Morales, S. P.; Roncero, O.; Jiménez-Serra, I.; Laas, J.; Hacar, A.; Kirk, J.; Lattanzi, V.; Martín-Doménech, R.; Muñoz-Caro, G.; Pineda, J. E.; Tercero, B.; Ward-Thompson, D.; Tafalla, M.; Marcelino, N.; Malinen, J.; Friesen, R.; Giuliano, B. M. "Gas phase Elemental abundances in Molecular cloudS (GEMS). IV. Observational results and statistical trends" *Astronomy and Astrophysics*, 648 :A120, 2021.
- Rojas-Ruiz, Sofía; Bañados, Eduardo; Neeleman, Marcel; Connor, Thomas; Eilers, Anna-Christina; Venemans, Bram P.; Khusanova, Yana; Carilli, Chris; Mazzucchelli, Chiara; Decarli, Roberto; Momjian, Emmanuel; Novak, Mladen "The Impact of Powerful Jets on the Far-infrared Emission of an Extreme Radio Quasar at z 6" *The Astrophysical Journal*, 920 :150, 2021.
- Romano, M.; Cassata, P.; Morselli, L.; Jones, G. C.; Ginolfi, M.; Zanella, A.; Béthermin, M.; Capak, P.; Faisst, A.; Le Fèvre, O.; Schaerer, D.; Silverman, J. D.; Yan, L.; Bardelli, S.; Boquien, M.; Cimatti, A.; Dessauges-Zavadsky, M.; Enia, A.; Fujimoto, S.; Gruppioni, C.; Hathi, N. P.; Ibar, E.; Koekemoer, A. M.; Lemaux, B. C.; Rodighiero, G.; Vergani, D.; Zamorani, G.; Zucca, E. "The ALPINE-ALMA [CII] survey. The contribution of major mergers to the galaxy mass assembly at z ~ 5" *Astronomy and Astrophysics*, 653 :A111, 2021.
- Rosario, D. J.; Alexander, D. M.; Moldon, J.; Klindt, L.; Thomson, A. P.; Morabito, L.; Fawcett, V. A.; Harrison, C. M. "Fundamental differences

## APPENDIX A: PUBLICATIONS

- in the radio properties of red and blue quasars: kiloparsec-scale structures revealed by e-MERLIN" *Monthly Notices of the Royal Astronomical Society*, 505 :5283, 2021.
- Rosotti, Giovanni P.; Ilee, John D.; Facchini, Stefano; Tazzari, Marco; Booth, Richard A.; Clarke, Cathie; Kama, Mihkel "High-resolution observations of molecular emission lines toward the CI Tau proto-planetary disc: planet-carved gaps or shadowing?" *Monthly Notices of the Royal Astronomical Society*, 501 :3427, 2021.
- Ross, K.; Callingham, J. R.; Hurlley-Walker, N.; Seymour, N.; Hancock, P.; Franzen, T. M. O.; Morgan, J.; White, S. V.; Bell, M. E.; Patil, P. "Spectral variability of radio sources at low frequencies" *Monthly Notices of the Royal Astronomical Society*, 501 :6139, 2021.
- Roth, Nathan X.; Milam, Stefanie N.; Cordiner, Martin A.; Bockelée-Morvan, Dominique; Biver, Nicolas; Boissier, Jérémie; Lis, Dariusz C.; Remijan, Anthony J.; Charnley, Steven B. "Leveraging the ALMA Atacama Compact Array for Cometary Science: An Interferometric Survey of Comet C/2015 ER61 (PanSTARRS) and Evidence for a Distributed Source of Carbon Monosulfide" *The Astrophysical Journal*, 921 :14, 2021.
- Roth, Nathan X.; Milam, Stefanie N.; Cordiner, Martin A.; Bockelée-Morvan, Dominique; Disanti, Michael A.; Boissier, Jérémie; Biver, Nicolas; Crovisier, Jacques; Russo, Neil Dello; Bonev, Boncho P.; Qi, Chunhua; Remijan, Anthony J.; Charnley, Steven B.; Gibb, Erika L.; Val-Borro, Miguel De; Jehin, Emmanuel "Rapidly Varying Anisotropic Methanol (CH<sub>3</sub>OH) Production in the Inner Coma of Comet 46P/Wirtanen as Revealed by the ALMA Atacama Compact Array" *The Planetary Science Journal*, 2 :55, 2021.
- Roueff, Antoine; Gerin, Maryvonne; Gratier, Pierre; Levrier, François; Pety, Jérôme; Gaudel, Mathilde; Goicoechea, Javier R.; Orkisz, Jan H.; De Souza Magalhaes, Victor; Vono, Maxime; Bardeau, Sébastien; Bron, Emeric; Chanutot, Jocelyn; Chainais, Pierre; Guzman, Viviana V.; Hughes, Annie; Kainulainen, Jouni; Languignon, David; Le Bourlot, Jacques; Le Petit, Franck; Liszt, Harvey S.; Marchal, Antoine; Miville-Deschênes, Marc-Antoine; Peretto, Nicolas; Roueff, Evelyne; Sievers, Albrecht "C<sub>18</sub>O, <sup>13</sup>CO, and <sup>12</sup>CO abundances and excitation temperatures in the Orion B molecular cloud. Analysis of the achievable precision in modeling spectral lines within the approximation of the local thermodynamic equilibrium" *Astronomy and Astrophysics*, 645 :A26, 2021.
- Roy, Namrata; Moravec, Emily; Bundy, Kevin; Hardcastle, Martin J.; Gürkan, Gülay; Diego Baldi, Ranieri; Leslie, Sarah K.; Masters, Karen; Gelfand, Joseph; Riffel, Rogerio; Riffel, Rogemar A.; Mingo Fernandez, Beatriz; Drabent, Alexander "Radio Morphology of Red Geysers" *The Astrophysical Journal*, 922 :230, 2021.
- Rubinur, K.; Kharb, P.; Das, M.; Rahna, P. T.; Honey, M.; Paswan, A.; Vaddi, S.; Murthy, J. "A multiwavelength study of the dual nuclei in Mrk 212" *Monthly Notices of the Royal Astronomical Society*, 500 :3908, 2021.
- Rudnick, Lawrence; Cotton, William; Knowles, Kenda; Kolokythas, Konstantinos "One Source, Two Source(s): Ribs and Tethers" *Galaxies*, 9 :81, 2021.
- Ruiz-Rodríguez, D.; Kastner, J.; Hily-Blant, P.; Forveille, T. "Tracing molecular stratification within an edge-on protoplanetary disk" *Astronomy and Astrophysics*, 646 :A59, 2021.
- Runnoe, Jessie C.; Boroson, Todd "Orientation and Accretion in a Representative Sample of Active Galactic Nuclei" *The Astrophysical Journal*, 919 :62, 2021.
- Russell, T. D.; Degenaar, N.; Den Eijnden, J. Van; Del Santo, M.; Segreto, A.; Altamirano, D.; Beri, A.; Díaz Trigo, M.; Miller-Jones, J. C. A. "The evolving radio jet from the neutron star X-ray binary 4U 1820-30" *Monthly Notices of the Royal Astronomical Society*, 508 :L6, 2021.
- Rybak, Matus; Da Cunha, E.; Groves, B.; Hodge, J. A.; Aravena, M.; Maseda, M.; Boogaard, L.; Berg, D.; Charlot, S.; Decarli, R.; Erb, D. K.; Nelson, E.; Pacifici, C.; Schmidt, K. B.; Walter, F.; Van Der Wel, A. "Ultrafaint [C II] Emission in a Redshift = 2 Gravitationally Lensed Metal-poor Dwarf Galaxy" *The Astrophysical Journal*, 909 :130, 2021.
- Sahu, Dipen; Liu, Sheng-Yuan; Liu, Tie; Evans, Neal J.; Ii, Hirano, Naomi; Tatematsu, Ken'ichi; Lee, Chin-Fei; Kim, Kee-Tae; Dutta, Somnath; Alina, Dana; Bronfman, Leonardo; Cunningham, Maria; Eden, David J.; Garay, Guido; Goldsmith, Paul F.; He, Jinhua; Hsu, Shih-Ying; Jhan, Kai-Syun; Johnstone, Doug; Juvela, Mika; Kim, Gwanjeong; Kuan, Yi-Jehng; Kwon, Woojin; Lee, Chang Won; Lee, Jeong-Eun; Li, Di; Li, Pak Shing; Li, Shanghuo; Luo, Qiu-Yi; Montillaud, Julien; Moraghan, Anthony; Pelkonen, Veli-Matti; Qin, Sheng-Li; Ristorcelli, Isabelle; Sanhueza, Patricio; Shang, Hsien; Shen, Zhi-Qiang; Soam, Archana; Wu, Yuefang; Zhang, Qizhou; Zhou, Jianjun "ALMA Survey of Orion Planck Galactic Cold Clumps (ALMASOP): Detection of Extremely High-density Compact Structure of Prestellar Cores and Multiple Substructures Within" *The Astrophysical Journal*, 907 :L15, 2021.
- Sakamoto, Kazushi; González-Alfonso, Eduardo; Martín, Sergio; Wilner, David J.; Aalto, Susanne; Evans, Aaron S.; Harada, Nanase "Deeply Buried Nuclei in the Infrared-luminous Galaxies NGC 4418 and Arp 220. I. ALMA Observations at  $\lambda = 1.4$ -0.4 mm and Continuum Analysis" *The Astrophysical Journal*, 923 :206, 2021.
- Sakamoto, Kazushi; Martín, Sergio; Wilner, David J.; Aalto, Susanne; Evans, Aaron S.; Harada, Nanase "Deeply Buried Nuclei in the Infrared-luminous Galaxies NGC 4418 and Arp 220. II. Line Forests at  $\lambda = 1.4$ -0.4 mm and Circumnuclear Gas Observed with ALMA" *The Astrophysical Journal*, 923 :240, 2021.
- Sakemi, Haruka; Omae, Rikuto; Ohmura, Takumi; Machida, Mami "Energy estimation of high-energy particles associated with the SS 433/W 50 system through radio observation at 1.4 GHz" *Publications of the Astronomical Society of Japan*, 73 :530, 2021.
- Salas, P.; Rugel, M. R.; Emig, K. L.; Kauffmann, J.; Menten, K. M.; Wyrowski, F.; Tielens, A. G. G. M. "The ionization fraction in OMC-2 and OMC-3" *Astronomy and Astrophysics*, 653 :A102, 2021.
- Sanchis, E.; Testi, L.; Natta, A.; Facchini, S.; Manara, C. F.; Miotello, A.; Ercolano, B.; Henning, Th.; Preibisch, T.; Carpenter, J. M.; De Gregorio-Monsalvo, I.; Jayawardhana, R.; Lopez, C.; Mužić, K.; Pascucci, I.; Santamaría-Miranda, A.; Van Terwisga, S.; Williams, J. P. "Measuring the ratio of the gas and dust emission radii of protoplanetary disks in the Lupus star-forming region" *Astronomy and Astrophysics*, 649 :A19, 2021.
- Sand, D. J.; Sarbadhicary, S. K.; Pellegrino, C.; Misra, K.; Dastidar, R.; Brown, P. J.; Itagaki, K.; Valenti, S.; Swift, Jonathan J.; Andrews, J. E.; Bostroem, K. A.; Burke, J.; Chomiuk, L.; Dong, Y.; Galbany, L.; Graham, M. L.; Hiramatsu, D.; Howell, D. A.; Hsiao, E. Y.; Janzen, D.; Jencson, J. E.; Lundquist, M. J.; McCully, C.; Reichart, D.; Smith, Nathan; Wang, Lingzhi; Wyatt, S. "Circumstellar Medium Constraints on the Environment of Two Nearby Type Ia Supernovae: SN 2017cbv and SN 2020nlb" *The Astrophysical Journal*, 922 :21, 2021.
- Sanhueza, Patricio; Girart, Josep Miquel; Padovani, Marco; Galli, Daniele; Hull, Charles L. H.; Zhang, Qizhou; Cortes, Paulo; Stephens, Ian W.; Fernández-López, Manuel; Jackson, James M.; Frau, Pau; Kock, Patrick M.; Wu, Benjamin; Zapata, Luis A.; Olguin, Fernando; Lu, Xing; Silva, Andrea; Tang, Ya-Wen; Sakai, Takeshi; Guzmán, Andrés E.; Tatematsu, Ken'ichi; Nakamura, Fumitaka; Chen, Huei-Ru Vivien "Gravity-driven Magnetic Field at 1000 au Scales in High-mass Star Formation" *The Astrophysical Journal*, 915 :L10, 2021.
- Sanna, A.; Giannetti, A.; Bonfand, M.; Moscadelli, L.; Kuiper, R.; Brand, J.; Cesaroni, R.; Caratti O Garatti, A.; Pillai, T.; Menten, K. M. "Physical conditions in the warped accretion disk of a massive star. 349 GHz ALMA observations of G023.01-00.41" *Astronomy and Astrophysics*, 655 :A72, 2021.
- Sano, H.; Yoshiike, S.; Yamane, Y.; Hayashi, K.; Enokiya, R.; Tokuda, K.; Tachihara, K.; Rowell, G.; Filipović, M. D.; Fukui, Y. "ALMA CO Observations of the Mixed-morphology Supernova Remnant W49B: Efficient Production of Recombining Plasma and Hadronic Gamma

- Rays via Shock-Cloud Interactions" *The Astrophysical Journal*, 919 :123, 2021.
- Sano, Hidetoshi; Tsuge, Kiyoharu; Tokuda, Kazuki; Muraoka, Kazuyuki; Tachihara, Kengo; Yamane, Yumiko; Kohno, Mikito; Fujita, Shinji; Enokiya, Rei; Rowell, Gavin; Maxted, Nigel; Filipović, Miroslav D.; Knies, Jonathan; Sasaki, Manami; Onishi, Toshikazu; Plucinsky, Paul P.; Fukui, Yasuo "ALMA CO observations of a giant molecular cloud in M 33: Evidence for high-mass star formation triggered by cloud-cloud collisions" *Publications of the Astronomical Society of Japan*, 73 :S62, 2021.
- Santamaría-Miranda, A.; De Gregorio-Monsalvo, I.; Plunkett, A. L.; Huélamo, N.; López, C.; Ribas, Á.; Schreiber, M. R.; Mužić, K.; Palau, A.; Knee, L. B. G.; Bayo, A.; Comerón, F.; Hales, A. "ALMA observations of the early stages of substellar formation in the Lupus 1 and 3 molecular clouds" *Astronomy and Astrophysics*, 646 :A10, 2021.
- Sarbadhicary, Sumit K.; Tremou, Evangelia; Stewart, Adam J.; Chomiuk, Laura; Peters, Charee; Hales, Chris; Strader, Jay; Momjian, Emmanuel; Fender, Rob; Wilcots, Eric M. "CHILES VERDES: Radio Variability at an Unprecedented Depth and Cadence in the COSMOS Field" *The Astrophysical Journal*, 923 :31, 2021.
- Sardone, Amy; Pisano, D. J.; Pingel, N. M.; Sorgho, A.; Carignan, Claude; De Blok, W. J. G. "A Census of the Extended Neutral Hydrogen around 18 MONGOOSE Galaxies" *The Astrophysical Journal*, 910 :69, 2021.
- Sato, Keisuke; Miyamoto, Yusuke; Kuno, Nario; Salak, Dragan; Wagner, Alexander Y.; Seta, Masumichi; Nakai, Naomasa "Relating gas dynamics to star formation in the central region of the barred spiral galaxy NGC 613" *Publications of the Astronomical Society of Japan*, 73 :1019, 2021.
- Sawada, Tsuyoshi; Chang, Chin-Shin; Francke, Harold; Gomez, Laura; Mangum, Jeffrey G.; Miyamoto, Yusuke; Nakazato, Takeshi; Nishie, Suminori; Phillips, Neil M.; Shimajiri, Yoshito; Sugimoto, Kanako "Offline Correction of Atmospheric Effects on Single-dish Radio Spectroscopy" *Publications of the Astronomical Society of the Pacific*, 133 :34504, 2021.
- Sbarrato, T.; Ghisellini, G.; Giovannini, G.; Giroletti, M. "Jetted radio-quiet quasars at  $z > 5$ " *Astronomy and Astrophysics*, 655 :A95, 2021.
- Scaife, Anna M. M.; Porter, Fiona "Fanaroff-Riley classification of radio galaxies using group-equivariant convolutional neural networks" *Monthly Notices of the Royal Astronomical Society*, 503 :2369, 2021.
- Schellenberger, Gerrit; David, Laurence P.; Vrtilik, Jan; O'Sullivan, Ewan; Giacintucci, Simona; Forman, William; Jones, Christine; Venturi, Tiziana "A New Feedback Cycle in the Archetypal Cooling Flow Group NGC 5044" *The Astrophysical Journal*, 906 :16, 2021.
- Schmiedeke, Anika; Pineda, Jaime E.; Caselli, Paola; Arce, Héctor G.; Fuller, Gary A.; Goodman, Alyssa A.; Maureira, María José; Offner, Stella S. R.; Segura-Cox, Dominique; Seifried, Daniel "Dissecting the Supercritical Filaments Embedded in the 0.5 pc Subsonic Region of Barnard 5" *The Astrophysical Journal*, 909 :60, 2021.
- Schneiderman, Tajana; Matrà, Luca; Jackson, Alan P.; Kennedy, Grant M.; Kral, Quentin; Marino, Sebastián; Öberg, Karin I.; Su, Kate Y. L.; Wilner, David J.; Wyatt, Mark C. "Carbon monoxide gas produced by a giant impact in the inner region of a young system" *Nature*, 598 :425, 2021.
- Scholtz, J.; Harrison, C. M.; Rosario, D. J.; Alexander, D. M.; Knudsen, K. K.; Stanley, F.; Chen, Chian-Chou; Kakkad, D.; Mainieri, V.; Mullaney, J. "The impact of ionized outflows from  $z = 2.5$  quasars is not through instantaneous in situ quenching: the evidence from ALMA and VLT/SINFONI" *Monthly Notices of the Royal Astronomical Society*, 505 :5469, 2021.
- Schreiber, C.; Glazebrook, K.; Papovich, C.; Díaz-Santos, T.; Verma, A.; Elbaz, D.; Kacprzak, G. G.; Nanayakkara, T.; Oesch, P.; Pannella, M.; Spitler, L.; Straatman, C.; Tran, K.-V.; Wang, T. "A low [CII]/[NII] ratio in the center of a massive galaxy at  $z = 3.7$ : Evidence for a transition to quiescence at high redshift?" *Astronomy and Astrophysics*, 646 :A68, 2021.
- Schulz, R.; Morganti, R.; Nyland, K.; Paragi, Z.; Mahony, E. K.; Oosterloo, T. "Parsec-scale HI outflows in powerful radio galaxies" *Astronomy and Astrophysics*, 647 :A63, 2021.
- Schwarz, Kamber R.; Calahan, Jenny K.; Zhang, Ke; Alarcón, Felipe; Aikawa, Yuri; Andrews, Sean M.; Bae, Jaehan; Bergin, Edwin A.; Booth, Alice S.; Bosman, Arthur D.; Cataldi, Gianni; Cleeves, L. Ilse; Czekala, Ian; Huang, Jane; Ilee, John D.; Law, Charles J.; Le Gal, Romane; Liu, Yao; Long, Feng; Loomis, Ryan A.; Macías, Enrique; McClure, Melissa; Ménard, François; Öberg, Karin I.; Teague, Richard; Van Dishoeck, Ewine; Walsh, Catherine; Wilner, David J. "Molecules with ALMA at Planet-forming Scales. XX. The Massive Disk around GM Aurigae" *The Astrophysical Journal Supplement Series*, 257 :20, 2021.
- Schwartz, Andria C.; Burrows, Andrea C. "Authentic science experiences with STEM datasets: post-secondary results and potential gender influences" *Research in Science and Technological Education*, 39 :347, 2021.
- Seifert, Richard A.; Cleeves, L. Ilse; Adams, Fred C.; Li, Zhi-Yun "Evidence for a Cosmic-Ray Gradient in the IM Lup Protoplanetary Disk" *The Astrophysical Journal*, 912 :136, 2021.
- Seta, Amit; Rodrigues, Luiz Felipe S.; Federrath, Christoph; Hales, Christopher A. "Magnetic Fields in Elliptical Galaxies: An Observational Probe of the Fluctuation Dynamo Action" *The Astrophysical Journal*, 907 :2, 2021.
- Sett, S.; Breton, R. P.; Clark, C. J.; Kerkwijk, M. H.; Kaplan, D. L. "A search for radio pulsars in five nearby supernova remnants" *Astronomy and Astrophysics*, 647 :A183, 2021.
- Shah, Hilay; Seta, Amit "Magnetic fields in elliptical galaxies: using the Laing-Garrington effect in radio galaxies and polarized emission from background radio sources" *Monthly Notices of the Royal Astronomical Society*, 508 :1371, 2021.
- Shanks, T.; Ansarnejad, B.; Bielby, R. M.; Heywood, I.; Metcalfe, N.; Wang, L. "The nature of sub-millimetre galaxies I: a comparison of AGN and star-forming galaxy SED fits" *Monthly Notices of the Royal Astronomical Society*, 505 :1509, 2021.
- Shaw, A. W.; Plotkin, R. M.; Miller-Jones, J. C. A.; Homan, J.; Gallo, E.; Russell, D. M.; Tomsick, J. A.; Kaaret, P.; Corbel, S.; Espinasse, M.; Bright, J. "Observations of the Disk/Jet Coupling of MAXI J1820+070 During its Descent to Quiescence" *The Astrophysical Journal*, 907 :12 pp, 2021.
- Shen, Jeff; Man, Allison W. S.; Zabl, Johannes; Zhang, Zhi-Yu; Stockmann, Mikkel; Brammer, Gabriel; Whitaker, Katherine E.; Richard, Johan "Molecular Gas in a Gravitationally Lensed Galaxy Group at  $z = 2.9$ " *The Astrophysical Journal*, 917 :79, 2021.
- Shen, Lu; Lemaux, Brian C.; Lubin, Lori M.; Cucciati, Olga; Le Fèvre, Olivier; Liu, Guilin; Fang, Wenjuan; Pelliccia, Debora; Tomczak, Adam; Mckean, John; Miller, Neal A.; Fassnacht, Christopher D.; Gal, Roy; Hung, Denise; Hathi, Nimish; Bardelli, Sandro; Vergani, Daniela; Zucca, Elena "Implications of the Environments of Radio-detected Active Galactic Nuclei in a Complex Protostructure at  $z \sim 3.3$ " *The Astrophysical Journal*, 912 :60, 2021.
- Shen, Yue; Chen, Yu-Ching; Hwang, Hsiang-Chih; Liu, Xin; Zakamska, Nadia; Oguri, Masamune; Li, Jennifer I. -Hsiu; Lazio, Joseph; Breiding, Peter "A hidden population of high-redshift double quasars unveiled by astrometry" *Nature Astronomy*, 5 :569, 2021.
- Shepard, Michael K.; De Kleer, Katherine; Cambioni, Saverio; Taylor, Patrick A.; Virkki, Anne K.; Rivera-Valentin, Edgard G.; Rodriguez Sanchez-Vahamonde, Carolina; Fernanda Zambrano-Marin, Luisa; Magri, Christopher; Dunham, David; Moore, John; Camarca, Maria "Asteroid 16 Psyche: Shape, Features, and Global Map" *The Planetary Science Journal*, 2 :125, 2021.
- Shi, Yong; Zhang, Zhi-Yu; Wang, Junzhi; Chen, Jianhang; Gu, Qiusheng; Yu, Xiaoling; Li, Songlin "A Cuspy Dark Matter Halo" *The Astrophysical Journal*, 909 :20, 2021.
- Shibayama, Yoshiki; Watanabe, Yoshimasa; Oya, Yoko; Sakai, Nami; López-Sepulcre, Ana; Liu, Sheng-Yuan; Su, Yu-Nung; Zhang, Yichen; Sakai, Takeshi; Hirota, Tomoya; Yamamoto, Satoshi "Exploring the 100 au Scale Structure of the Protobinary System NGC 2264 CMM3 with

## APPENDIX A: PUBLICATIONS

- ALMA" The Astrophysical Journal, 918 :32, 2021.
- Shimizu, Toshifumi; Shimojo, Masumi; Abe, Masashi "Simultaneous ALMA-Hinode-IRIS Observations on Footpoint Signatures of a Soft X-Ray Loop-like Microflare" The Astrophysical Journal, 922 :113, 2021.
- Shimonishi, Takashi; Izumi, Natsuko; Furuya, Kenji; Yasui, Chikako "The Detection of a Hot Molecular Core in the Extreme Outer Galaxy" The Astrophysical Journal, 922 :206, 2021.
- Shingledecker, C. N.; Lee, K. L. K.; Wandishin, J. T.; Balucani, N.; Burkhardt, A. M.; Charnley, S. B.; Loomis, R.; Schreffler, M.; Siebert, M.; McCarthy, M. C.; Mcguire, B. A. "Detection of interstellar H<sub>2</sub>CCCH<sub>3</sub>N. A possible link between chains and rings in cold cores" Astronomy and Astrophysics, 652 :L12, 2021.
- Shukla, Gitika; Srikanand, Raghunathan; Gupta, Neeraj; Petitjean, Patrick; Baker, Andrew J.; Krogager, Jens-Kristian; Noterdaeme, Pasquier "Lyman- $\alpha$  emission from a WISE-selected optically faint powerful radio galaxy M151304.72-252439.7 at  $z = 3.132$ " Monthly Notices of the Royal Astronomical Society, 501 :5362, 2021.
- Shuvo, Onic I.; Araya, E. D.; Tan, W. S.; Hofner, P.; Kurtz, S.; Pihlström, Y. M.; Hoffman, I. M. "Thermal formaldehyde emission in NGC 7538 IRS 1" Monthly Notices of the Royal Astronomical Society, 504 :1733, 2021.
- Sierra, Anibal; Pérez, Laura M.; Zhang, Ke; Law, Charles J.; Guzmán, Viviana V.; Qi, Chunhua; Bosman, Arthur D.; Öberg, Karin I.; Andrews, Sean M.; Long, Feng; Teague, Richard; Booth, Alice S.; Walsh, Catherine; Wilner, David J.; Ménard, François; Cataldi, Gianni; Czekala, Ian; Bae, Jaehan; Huang, Jane; Bergner, Jennifer B.; Ilee, John D.; Benisty, Myriam; Le Gal, Romane; Loomis, Ryan A.; Tsukagoshi, Takashi; Liu, Yao; Yamato, Yoshihide; Aikawa, Yuri "Molecules with ALMA at Planet-forming Scales (MAPS). XIV. Revealing Disk Substructures in Multiwavelength Continuum Emission" The Astrophysical Journal Supplement Series, 257 :14, 2021.
- Silpa, S.; Kharb, P.; Harrison, C. M.; Ho, L. C.; Jarvis, M. E.; Ishwara-Chandra, C. H.; Sebastian, B. "Outflows in the radio-intermediate quasar III Zw 2: a polarization study with the EVLA and uGMRT" Monthly Notices of the Royal Astronomical Society, 507 :991, 2021.
- Silpa, S.; Kharb, P.; O'Dea, C. P.; Baum, S. A.; Sebastian, B.; Mukherjee, D.; Harrison, C. M. "AGN jets and winds in polarized light: the case of Mrk 231" Monthly Notices of the Royal Astronomical Society, 507 :2550, 2021.
- Silva, Andrea; Marchesini, Danilo; Silverman, John D.; Martis, Nicholas; Iono, Daisuke; Espada, Daniel; Skelton, Rosalind "Galaxy Mergers up to  $z < 2.5$ . II. AGN Incidence in Merging Galaxies at Separations of 3-15 kpc" The Astrophysical Journal, 909 :124, 2021.
- Singh, Ayushi; Matzner, Christopher D.; Friesen, Rachel K.; Martin, Peter G.; Pineda, Jaime E.; Rosolowsky, Erik; Alves, Felipe; Chacón-Tanarro, Ana; Chen, Hope How-Huan; Chen, Michael Chun-Yuan; Choudhury, Spandan; Di Francesco, James; Keown, Jared; Kirk, Helen; Punanova, Anna; Seo, Youngmin; Shirley, Yancy; Ginsburg, Adam; Offner, Stella S. R.; Arce, Héctor G.; Caselli, Paola; Goodman, Alyssa A.; Myers, Philip C.; Redaelli, Elena; Redaelli, Elena; Gas Collaboration "Are Massive Dense Clumps Truly Subvirial? A New Analysis Using Gould Belt Ammonia Data" The Astrophysical Journal, 922 :87, 2021.
- Singh, Veeresh; Dutta, Sushant; Wadadekar, Yogesh; Ishwara-Chandra, C. H. "Remnant Radio Galaxy Candidates of Small Angular Sizes" Galaxies, 9 :121, 2021.
- Singha, M.; O'Dea, C. P.; Gordon, Y. A.; Lawlor-Forsyth, C.; Baum, S. A. "Ionized Gas Outflows in Low-excitation Radio Galaxies Are Radiation Driven" The Astrophysical Journal, 918 :65, 2021.
- Smail, Ian; Dudzevičiūtė, U.; Stach, S. M.; Almaini, O.; Birkin, J. E.; Chapman, S. C.; Chen, Chian-Chou; Geach, J. E.; Gullberg, B.; Hodge, J. A.; Ikarashi, S.; Ivison, R. J.; Scott, D.; Simpson, Chris; Swinbank, A. M.; Thomson, A. P.; Walter, F.; Wardlow, J. L.; Van Der Werf, P. "An ALMA survey of the S2CLS UDS field: optically invisible submillimetre galaxies" Monthly Notices of the Royal Astronomical Society, 502 :3426, 2021.
- Smith, Mark D.; Bureau, Martin; Davis, Timothy A.; Cappellari, Michele; Liu, Lijie; Onishi, Kyoko; Iguchi, Satoru; North, Eve V.; Sarzi, Marc "WISDOM project - VI. Exploring the relation between supermassive black hole mass and galaxy rotation with molecular gas" Monthly Notices of the Royal Astronomical Society, 500 :1933, 2021.
- Smith, Mark D.; Bureau, Martin; Davis, Timothy A.; Cappellari, Michele; Liu, Lijie; Onishi, Kyoko; Iguchi, Satoru; North, Eve V.; Sarzi, Marc; Williams, Thomas G. "WISDOM project - VII. Molecular gas measurement of the supermassive black hole mass in the elliptical galaxy NGC 7052" Monthly Notices of the Royal Astronomical Society, 503 :5984, 2021.
- Snios, Bradford; Schwartz, Daniel A.; Siemiginowska, Aneta; Sobolewska, Małgosia; Birkinshaw, Mark; Cheung, C. C.; Gobeille, Doug B.; Marshall, Herman L.; Migliori, Giulia; Wardle, John F. C.; Worrall, Diana M. "Discovery of Candidate X-Ray Jets in High-redshift Quasars" The Astrophysical Journal, 914 :130, 2021.
- Soam, Archana "On the photoevaporation, dust polarization and kinematics of two nebulae in Sh2-236" Research in Astronomy and Astrophysics, 21 :87, 2021.
- Sofue, Yoshiaki; Kohno, Mikito; Umamoto, Tomofumi "Atlas of CO-line Shells and Cavities around Galactic Supernova Remnants with FUGIN" The Astrophysical Journal Supplement Series, 253 :17, 2021.
- Solimano, M.; González-López, J.; Barrientos, L. F.; Aravena, M.; López, S.; Tejos, N.; Sharon, K.; Dahle, H.; Bayliss, M.; Ledoux, C.; Rigby, J. R.; Gladders, M. "Molecular gas budget and characterization of intermediate-mass star-forming galaxies at  $z \approx 2-3$ " Astronomy and Astrophysics, 655 :A42, 2021.
- Song, Y.; Linden, S. T.; Evans, A. S.; Barcos-Muñoz, L.; Privon, G. C.; Yoon, I.; Murphy, E. J.; Larson, K. L.; Díaz-Santos, T.; Armus, L.; Mazzarella, Joseph M.; Howell, J.; Inami, H.; Torres-Albà, N.; U, V.; Charmandaris, V.; Mckinney, J.; Kunneriath, D.; Momjian, E. "A Comparison between Nuclear Ring Star Formation in LIRGs and in Normal Galaxies with the Very Large Array" The Astrophysical Journal, 916 :73, 2021.
- Soria, R.; Pakull, M. W.; Motch, C.; Miller-Jones, J. C. A.; Schwope, A. D.; Urquhart, R. T.; Ryan, M. S. "The ultraluminous X-ray source bubble in NGC 5585" Monthly Notices of the Royal Astronomical Society, 501 :1644, 2021.
- Sotnikova, Yu; Mikhailov, A.; Mufakharov, T.; Mingaliev, M.; Bursov, N.; Semenova, T.; Stolyarov, V.; Udovitskiy, R.; Kudryashova, A.; Erkenov, A. "High-redshift quasars at  $z \geq 3$  - I. Radio spectra" Monthly Notices of the Royal Astronomical Society, 508 :2798, 2021.
- Spear, Stephanie; José Maureira, María; Arce, Héctor G.; Pineda, Jaime E.; Dunham, Michael; Caselli, Paola; Segura-Cox, Dominique "VLA and NOEMA Views of Bok Globule CB 17: The Starless Nature of a Proposed First Hydrostatic Core Candidate" The Astrophysical Journal, 923 :231, 2021.
- Spérone-Longin, D.; Jablonka, P.; Combes, F.; Castignani, G.; Krips, M.; Rudnick, G.; Desjardins, T.; Zaritsky, D.; Finn, R. A.; De Lucia, G.; Desai, V. "SEEDisCS. II. Molecular gas in galaxy clusters and their large-scale structure: low gas fraction galaxies, the case of CL1301.7-1139" Astronomy and Astrophysics, 654 :A69, 2021.
- Spérone-Longin, D.; Jablonka, P.; Combes, F.; Castignani, G.; Krips, M.; Rudnick, G.; Zaritsky, D.; Finn, R. A.; De Lucia, G.; Desai, V. "SEEDisCS. I. Molecular gas in galaxy clusters and their large-scale structure: The case of CL1411.1-1148 at  $z \approx 0.5$ " Astronomy and Astrophysics, 647 :A156, 2021.
- Spinoglio, Luigi; Mordini, Sabrina; Fernández-Ontiveros, Juan Antonio; Alonso-Herrero, Almudena; Armus, Lee; Bisigello, Laura; Calura, Francesco; Carrera, Francisco J.; Cooray, Asantha; Dannerbauer, Helmut; Decarli, Roberto; Egami, Eiichi; Elbaz, David; Franceschini, Alberto; González Alfonso, Eduardo; Graziani, Luca; Gruppioni, Carlotta; Hatziminaoglou, Evanthia; Kaneda, Hidehiro; Kohno, Kotaro; Labiano, Álvaro; Magdis, Georgios; Malkan, Matthew A.; Matsuhara, Hideo; Nagao, Tohru; Naylor, David; Pereira-Santaella, Miguel; Pozzi, Francesca; Rodighiero, Giulia; Roelfsema, Peter; Serjeant, Stephen; Vignali, Cristian; Wang, Lingyu; Yamada, Toru "Mid-IR cosmological



- spectrophotometric surveys from space: Measuring AGN and star formation at the cosmic noon with a SPICA-like mission" *Publications of the Astronomical Society of Australia*, 38 :e021, 2021.
- Sprenger, Tim; Wucknitz, Olaf; Main, Robert; Baker, Daniel; Briske, Walter "The  $\theta$ - $\theta$  Diagram: Transforming pulsar scintillation spectra to coordinates on highly anisotropic interstellar scattering screens" *Monthly Notices of the Royal Astronomical Society*, 500 :1114-1124, 2021.
- Stacey, H. R.; Mckean, J. P.; Powell, D. M.; Vegetti, S.; Rizzo, F.; Spingola, C.; Auger, M. W.; Ivison, R. J.; Van Der Werf, P. P. "The rocky road to quiescence: compaction and quenching of quasar host galaxies at  $z \sim 2$ " *Monthly Notices of the Royal Astronomical Society*, 500 :3667, 2021.
- Stanley, F.; Knudsen, K. K.; Aalto, S.; Fan, L.; Falstad, N.; Humphreys, E. "Detection of H<sub>2</sub>O and OH+ in  $z > 3$  hot dust-obscured galaxies" *Astronomy and Astrophysics*, 646 :A178, 2021.
- Stark, David V.; Masters, Karen L.; Avila-Reese, Vladimir; Riffel, Rogemar; Riffel, Rogerio; Boardman, Nicholas Fraser; Zheng, Zheng; Weijmans, Anne-Marie; Dillon, Sean; Fielder, Catherine; Finnegan, Daniel; Fofie, Patricia; Goddy, Julian; Harrington, Emily; Pace, Zachary; Rujopakarn, Wiphu; Samson, Nattida; Shamsi, Shoaib; Sharma, Anubhav; Warrick, Elizabeth; Witherspoon, Catherine; Wolthuis, Nathan "H I-MaNGA: tracing the physics of the neutral and ionized ISM with the second data release" *Monthly Notices of the Royal Astronomical Society*, 503 :1345, 2021.
- Stauffer, C. M.; Margutti, R.; Linford, J. D.; Chomiuk, L.; Coppejans, D. L.; Demarchi, L.; Jacobson-Galán, W.; Bright, J.; Foley, R. J.; Horesh, A.; Baldeschi, A. "Constraints on the sub-pc environment of the nearby type Ia SN 2014dt from deep X-ray and radio observations" *Monthly Notices of the Royal Astronomical Society*, 505 :1153, 2021.
- Stecklum, B.; Wolf, V.; Linz, H.; Caratti O Garatti, A.; Schmid, S.; Klose, S.; Eislöffel, J.; Fischer, Ch.; Brogan, C.; Burns, R. A.; Bayandina, O.; Cyganowski, C.; Gurwell, M.; Hunter, T.; Hirano, N.; Kim, K.-T.; Macleod, G.; Menten, K. M.; Olech, M.; Orosz, G.; Sobolev, A.; Sridharan, T. K.; Surcis, G.; Sugiyama, K.; Van Der Walt, J.; Volvach, A.; Yonekura, Y. "Infrared observations of the flaring maser source G358.93-0.03. SOFIA confirms an accretion burst from a massive young stellar object" *Astronomy and Astrophysics*, 646 :A161, 2021.
- Stein, Robert; Velzen, Sjoert Van; Kowalski, Marek; Franckowiak, Anna; Gezari, Suvii; Miller-Jones, James C. A.; Frederick, Sara; Sfaradi, Itai; Bietenholz, Michael F.; Horesh, Assaf; Fender, Rob; Garrappa, Simone; Ahumada, Tomás; Andreoni, Igor; Belicki, Justin; Bellm, Eric C.; Böttcher, Markus; Brinnet, Valery; Burruss, Rick; Cenko, S. Bradley; Coughlin, Michael W.; Cunningham, Virginia; Drake, Andrew; Farrar, Glennys R.; Feeney, Michael; Foley, Ryan J.; Gal-Yam, Avishay; Golkhou, V. Zach; Goobar, Ariel; Graham, Matthew J.; Hammerstein, Erica; Helou, George; Hung, Tiara; Kasliwal, Mansi M.; Kilpatrick, Charles D.; Kong, Albert K. H.; Kupfer, Thomas; Laher, Russ R.; Mahabal, Ashish A.; Masci, Frank J.; Necker, Jannis; Nordin, Jakob; Perley, Daniel A.; Rigault, Mickael; Reusch, Simeon; Rodríguez, Hector; Rojas-Bravo, César; Rusholme, Ben; Shupe, David L.; Singer, Leo P.; Sollerman, Jesper; Soumagnac, Maayane T.; Stern, Daniel; Taggart, Kirsty; Van Santen, Jakob; Ward, Charlotte; Woudt, Patrick; Yao, Yuhan "A tidal disruption event coincident with a high-energy neutrino" *Nature Astronomy*, 5 :p. 510-518, 2021.
- Stroe, Andra; Sobral, David "ENISALA. II. Distinct Star Formation and Active Galactic Nucleus Activity in Merging and Relaxed Galaxy Clusters" *The Astrophysical Journal*, 912 :55, 2021.
- Stroh, Michael C.; Terreran, Giacomo; Coppejans, Deanne L.; Bright, Joe S.; Margutti, Raffaella; Bietenholz, Michael F.; De Colle, Fabio; Demarchi, Lindsay; Duran, Rodolfo Barniol; Millisavljevic, Danny; Murase, Kohta; Paterson, Kerry; Williams, Wendy L. "Luminous Late-time Radio Emission from Supernovae Detected by the Karl G. Jansky Very Large Array Sky Survey (VLASS)" *The Astrophysical Journal*, 923 :L24, 2021.
- Stuardi, C.; Bonafede, A.; Lovisari, L.; Domínguez-Fernández, P.; Vazza, F.; Brügggen, M.; Van Weeren, R. J.; De Gasperin, F. "The intracluster magnetic field in the double relic galaxy cluster Abell 2345" *Monthly Notices of the Royal Astronomical Society*, 502 :2518, 2021.
- Stuber, Sophia K.; Saito, Toshiki; Schinnerer, Eva; Emsellem, Eric; Querejeta, Miguel; Williams, Thomas G.; Barnes, Ashley T.; Bigiel, Frank; Blanc, Guillermo; Dale, Daniel A.; Grasha, Kathryn; Klessen, Ralf; Kruijssen, J. M. Diederik; Leroy, Adam K.; Meidt, Sharon; Pan, Hsi-An; Rosolowsky, Erik; Schrubba, Andreas; Sun, Jiayi; Usero, Antonio "Frequency and nature of central molecular outflows in nearby star-forming disk galaxies" *Astronomy and Astrophysics*, 653 :A172, 2021.
- Suárez, Genaro; Galván-Madrid, Roberto; Aguilar, Luis; Ginsburg, Adam; Srinivasan, Sundar; Liu, Hanyu Baobab; Román-Zúñiga, Carlos G. "A Core Mass Function Indistinguishable from the Salpeter Stellar Initial Mass Function Using 1000 au Resolution ALMA Observations" *The Astrophysical Journal*, 921 :48, 2021.
- Sugahara, Yuma; Inoue, Akio K.; Hashimoto, Takuya; Yamanaka, Satoshi; Fujimoto, Seiji; Tamura, Yoichi; Matsuo, Hiroshi; Binggeli, Christian; Zackrisson, Erik "Big Three Dragons: A [N II] 122  $\mu$ m Constraint and New Dust-continuum Detection of a  $z = 7.15$  Bright Lyman-break Galaxy with ALMA" *The Astrophysical Journal*, 923 :5, 2021.
- Sullivan, Colin H.; Fissel, L. M.; King, P. K.; Chen, C.-Y.; Li, Z.-Y.; Soler, J. D. "Characterising the magnetic fields of nearby molecular clouds using submillimeter polarization observations" *Monthly Notices of the Royal Astronomical Society*, 503 :pp.5006-5024, 2021.
- Sun, Fengwu; Egami, Eiichi; Rawle, Timothy D.; Walth, Gregory L.; Smail, Ian; Dessauges-Zavadsky, Miroslava; Pérez-González, Pablo G.; Richard, Johan; Combes, Françoise; Ebeling, Harald; Pelló, Roser; Van Der Werf, Paul; Altieri, Bruno; Boone, Frédéric; Cava, Antonio; Chapman, Scott C.; Clément, Benjamin; Finoguenov, Alexis; Nakajima, Kimihiko; Rujopakarn, Wiphu; Schaerer, Daniel; Valtchanov, Ivan "ALMA 1.3 mm Survey of Lensed Submillimeter Galaxies Selected by Herschel: Discovery of Spatially Extended SMGs and Implications" *The Astrophysical Journal*, 908 :192, 2021.
- Suresh, Akshay; Cordes, James M.; Chatterjee, Shami; Gajjar, Vishal; Perez, Karen I.; Siemion, Andrew P. V.; Price, Danny C. "4-8 GHz Spectrotemporal Emission from the Galactic Center Magnetar PSR J1745-2900" *The Astrophysical Journal*, 921 :101, 2021.
- Suzuki, Tomoko L.; Onodera, Masato; Kodama, Tadayuki; Daddi, Emanuele; Hayashi, Masao; Koyama, Yusei; Shimakawa, Rhythm; Smail, Ian; Sobral, David; Tacchella, Sandro; Tanaka, Ichi "Dust, Gas, and Metal Content in Star-forming Galaxies at  $z \sim 3.3$  Revealed with ALMA and Near-IR Spectroscopy" *The Astrophysical Journal*, 908 :15, 2021.
- Szakacs, Roland; Péroux, Céline; Zwaan, Martin; Hamañowicz, Aleksandra; Klitsch, Anne; Fresco, Alejandra Y.; Augustin, Ramona; Biggs, Andrew; Kulkarni, Varsha; Rahmani, Hadi "MUSE-ALMA haloes VI: coupling atomic, ionized, and molecular gas kinematics of galaxies" *Monthly Notices of the Royal Astronomical Society*, 505 :4746, 2021.
- Tafuya, Daniel; Sanhueza, Patricio; Zhang, Qizhou; Li, Shanghuo; Guzmán, Andrés E.; Silva, Andrea; De La Fuente, Eduardo; Lu, Xing; Morii, Kaho; Tatematsu, Ken'ichi; Contreras, Yanett; Izumi, Natsuko; Jackson, James M.; Nakamura, Fumitaka; Sakai, Takeshi "The ALMA Survey of 70  $\mu$ m Dark High-mass Clumps in Early Stages (ASHES). III. A Young Molecular Outflow Driven by a Decelerating Jet" *The Astrophysical Journal*, 913 :131, 2021.
- Takemura, Hideaki; Nakamura, Fumitaka; Kong, Shuo; Arce, Héctor G.; Carpenter, John M.; Ossenkopf-Okada, Volker; Klessen, Ralf; Sanhueza, Patricio; Shimajiri, Yoshito; Tsukagoshi, Takashi; Kawabe, Ryohei; Ishii, Shun; Dobashi, Kazuhito; Shimoikura, Tomomi; Goldsmith, Paul F.; Sánchez-Monge, Álvaro; Kauffmann, Jens; Pillai, Thushara G. S.; Padoan, Paolo; Ginsberg, Adam; Smith, Rowan J.; Bally, John; Mairs, Steve; Pineda, Jaime E.; Lis, Dariusz C.; Burkhart, Blakesley; Schilke, Peter; Chen, Hope How-Huan; Isella, Andrea; Friesen, Rachel K.; Goodman, Alyssa A.; Harper, Doyal A. "The Core Mass Function in the Orion Nebula Cluster Region: What Determines the Final Stellar

## APPENDIX A: PUBLICATIONS

- Masses?" *The Astrophysical Journal*, 910 :L6, 2021.
- Talia, Margherita; Cimatti, Andrea; Giuliotti, Marika; Zamorani, Gianni; Bethermin, Matthieu; Faisst, Andreas; Le Fèvre, Olivier; Smolčić, Vernesa "Illuminating the Dark Side of Cosmic Star Formation Two Billion Years after the Big Bang" *The Astrophysical Journal*, 909 :23, 2021.
- Tan, Jianrong; Liu, Adrian; Kern, Nicholas S.; Abdurashidova, Zara; Aguirre, James E.; Alexander, Paul; Ali, Zaki S.; Balfour, Yanga; Beardsley, Adam P.; Bernardi, Gianni; Billings, Tashalee S.; Bowman, Judd D.; Bradley, Richard F.; Bull, Philip; Burba, Jacob; Carey, Steven; Carilli, Christopher L.; Cheng, Carina; Deboer, David R.; Dexter, Matt; De Lera Acedo, Eloy; Dillon, Joshua S.; Ely, John; Ewall-Wice, Aaron; Fagnoni, Nicolas; Fritz, Randall; Furlanetto, Steve R.; Gale-Sides, Kingsley; Glendenning, Brian; Gorthi, Deepthi; Greig, Bradley; Grobbelaar, Jasper; Halday, Ziyaad; Hazelton, Bryna J.; Hewitt, Jacqueline N.; Hickish, Jack; Jacobs, Daniel C.; Julius, Austin; Kerrigan, Joshua; Kittiwisit, Piyanat; Kohn, Saul A.; Kolopanis, Matthew; Lanman, Adam; La Plante, Paul; Lekalake, Telalo; Macmahon, David; Malan, Lourence; Malgas, Cresshim; Maree, Matthys; Martinot, Zachary E.; Matsetela, Eunice; Mesinger, Andrei; Molewa, Mathakane; Morales, Miguel F.; Mosiane, Tshegofalang; Murray, Steven G.; Neben, Abraham R.; Nikolic, Bojan; Nunhokee, Chuneeta D.; Parsons, Aaron R.; Patra, Nipanjana; Pieterse, Samantha; Pober, Jonathan C.; Razavi-Ghods, Nima; Ringuette, Jon; Robnett, James; Rosie, Kathryn; Sims, Peter; Singh, Saurabh; Smith, Craig; Syce, Angelo; Thyagarajan, Nithyanandan; Williams, Peter K. G.; Zheng, Haoxuan "Methods of Error Estimation for Delay Power Spectra in 21 cm Cosmology" *The Astrophysical Journal Supplement Series*, 255 :26, 2021.
- Tan, Qing-Hua; Gao, Yu; Daddi, Emanuele; Xia, Xiao-Yang; Hao, Cai-Na; Omont, Alain; Kohno, Kotaro "Deep Observations of CO and Free-Free Emission in Ultraluminous Infrared QSO IRAS F07599+6508" *The Astrophysical Journal*, 913 :82, 2021.
- Tang, X. D.; Henkel, C.; Menten, K. M.; Gong, Y.; Chen, C.-H. R.; Li, D. L.; Lee, M.-Y.; Mangum, J. G.; Ao, Y. P.; Mühle, S.; Aalto, S.; García-Burillo, S.; Martín, S.; Viti, S.; Müller, S.; Costagliola, F.; Asiri, H.; Levshakov, S. A.; Spaans, M.; Ott, J.; Impellizzeri, C. M. V.; Fukui, Y.; He, Y. X.; Esimbek, J.; Zhou, J. J.; Zheng, X. W.; Zhao, X.; Li, J. S. "Kinetic temperature of massive star-forming molecular clumps measured with formaldehyde. IV. The ALMA view of N113 and N159W in the LMC" *Astronomy and Astrophysics*, 655 :A12, 2021.
- Taniguchi, Kotomi; Majumdar, Liton; Plunkett, Adele; Takakuwa, Shigehisa; Lis, Dariusz C.; Goldsmith, Paul F.; Nakamura, Fumitaka; Saito, Masao; Herbst, Eric "Chemical Compositions in the Vicinity of Protostars in Ophiuchus" *The Astrophysical Journal*, 922 :152, 2021.
- Taniguchi, Kotomi; Majumdar, Liton; Takakuwa, Shigehisa; Saito, Masao; Lis, Dariusz C.; Goldsmith, Paul F.; Herbst, Eric "Carbon-chain Chemistry versus Complex-organic-molecule Chemistry in Envelopes around Three Low-mass Young Stellar Objects in the Perseus Region" *The Astrophysical Journal*, 910 :141, 2021.
- Taniguchi, Kotomi; Plunkett, Adele; Shimoikura, Tomomi; Dobashi, Kazuhito; Saito, Masao; Nakamura, Fumitaka; Herbst, Eric "Clump-scale chemistry in the NGC 2264-D cluster-forming region" *Publications of the Astronomical Society of Japan*, 73 :1540, 2021.
- Tarantino, Elizabeth; Bolatto, Alberto D.; Herrera-Camus, Rodrigo; Harris, Andrew I.; Wolfire, Mark; Buchbender, Christof; Croxall, Kevin V.; Dale, Daniel A.; Groves, Brent; Levy, Rebecca C.; Riquelme, Denise; Smith, J. -D. T.; Stutzki, Jürgen "Characterizing the Multiphase Origin of [C II] Emission in M101 and NGC 6946 with Velocity-resolved Spectroscopy" *The Astrophysical Journal*, 915 :92, 2021.
- Tauscher, Keith; Rapetti, David; Nhan, Bang D.; Handy, Alec; Bassett, Neil; Hibbard, Joshua; Bordenave, David; Bradley, Richard F.; Burns, Jack O. "Global 21 cm Signal Extraction from Foreground and Instrumental Effects. IV. Accounting for Realistic Instrument Uncertainties and Their Overlap with Foreground and Signal Models" *The Astrophysical Journal*, 915 :66, 2021.
- Tazzari, M.; Clarke, C. J.; Testi, L.; Williams, J. P.; Facchini, S.; Manara, C. F.; Natta, A.; Rosotti, G. "Multiwavelength continuum sizes of protoplanetary discs: scaling relations and implications for grain growth and radial drift" *Monthly Notices of the Royal Astronomical Society*, 506 :2804, 2021.
- Tazzari, M.; Testi, L.; Natta, A.; Williams, J. P.; Ansdell, M.; Carpenter, J. M.; Facchini, S.; Guidi, G.; Hogherheijde, M.; Manara, C. F.; Miotello, A.; Van Der Marel, N. "The first ALMA survey of protoplanetary discs at 3 mm: demographics of grain growth in the Lupus region" *Monthly Notices of the Royal Astronomical Society*, 506 :5117, 2021.
- Teague, Richard; Bae, Jaehan; Aikawa, Yuri; Andrews, Sean M.; Bergin, Edwin A.; Bergner, Jennifer B.; Boehler, Yann; Booth, Alice S.; Bosman, Arthur D.; Cataldi, Gianni; Czekala, Ian; Guzmán, Viviana V.; Huang, Jane; Ilee, John D.; Law, Charles J.; Le Gal, Romane; Long, Feng; Loomis, Ryan A.; Ménard, François; Öberg, Karin I.; Pérez, Laura M.; Schwarz, Kamber R.; Sierra, Anibal; Walsh, Catherine; Wilner, David J.; Yamato, Yoshihide; Zhang, Ke "Molecules with ALMA at Planet-forming Scales (MAPS). XVIII. Kinematic Substructures in the Disks of HD 163296 and MWC 480" *The Astrophysical Journal Supplement Series*, 257 :18, 2021.
- Teague, Richard; Hull, Charles L. H.; Guilloteau, Stéphane; Bergin, Edwin A.; Dutrey, Anne; Henning, Thomas; Kuiper, Rolf; Semenov, Dmitry; Stephens, Ian W.; Vlemmings, Wouter H. T. "Discovery of Molecular-line Polarization in the Disk of TW Hya" *The Astrophysical Journal*, 922 :139, 2021.
- Terwisscha Van Scheltinga, Jeroen; Hogerheijde, Michiel R.; Cleeves, L. Ilse; Loomis, Ryan A.; Walsh, Catherine; Öberg, Karin I.; Bergin, Edwin A.; Bergner, Jennifer B.; Blake, Geoffrey A.; Calahan, Jenny K.; Cazzoletti, Paolo; Van Dishoeck, Ewine F.; Guzmán, Viviana V.; Huang, Jane; Kama, Mihkel; Qi, Chunhua; Teague, Richard; Wilner, David J. "The TW Hya Rosetta Stone Project. II. Spatially Resolved Emission of Formaldehyde Hints at Low-temperature Gas-phase Formation" *The Astrophysical Journal*, 906 :111, 2021.
- Tetarenko, A. J.; Casella, P.; Miller-Jones, J. C. A.; Sivakoff, G. R.; Paice, J. A.; Vincentelli, F. M.; Maccarone, T. J.; Gandhi, P.; Dhillon, V. S.; Marsh, T. R. "Measuring fundamental jet properties with multi-wavelength fast timing of the black hole X-ray binary MAXI J1820+070" *Monthly Notices of the Royal Astronomical Society*, 504 :3862, 2021.
- Thimmappa, R.; Stawarz, Ł.; Pajdosz-Śmierciak, U.; Balasubramaniam, K.; Marchenko, V. "Complex Structure of the Eastern Lobe of the Pictor A Radio Galaxy: Spectral Analysis and X-Ray/Radio Correlations" *The Astrophysical Journal*, 921 :44, 2021.
- Thomson, Alec J. M.; Landecker, T. L.; McClure-Griffiths, N. M.; Dickey, John M.; Campbell, J. L.; Carretti, Ettore; Clark, S. E.; Federrath, Christoph; Gaensler, B. M.; Han, J. L.; Haverkorn, Marijke; Hill, Alex S.; Mao, S. A.; Ordog, Anna; Pratley, Luke; Reich, Wolfgang; Van Eck, Cameron L.; West, J. L.; Wolleben, M. "The Global Magneto-Ionic Medium Survey (GMIMS): the brightest polarized region in the southern sky at 75 cm and its implications for Radio Loop II" *Monthly Notices of the Royal Astronomical Society*, 507 :3495, 2021.
- Timmerman, R.; Van Weeren, R. J.; McDonald, M.; Ignesti, A.; McNamara, B. R.; Hlavacek-Larrondo, J.; Röttgering, H. J. A. "Very Large Array observations of the mini-halo and AGN feedback in the Phoenix cluster" *Astronomy and Astrophysics*, 646 :A38, 2021.
- Tokuda, Kazuki; Kondo, Hiroshi; Ohno, Takahiro; Konishi, Ayu; Sano, Hidetoshi; Tsuge, Kiyosumi; Zahorec, Sarolta; Goto, Nao; Neelamkodan, Naslim; Wong, Tony; Sewito, Marta; Fukushima, Hajime; Takekoshi, Tatsuya; Muraoka, Kazuyuki; Kawamura, Akiko; Tachihara, Kengo; Fukui, Yasuo; Onishi, Toshikazu "An Unbiased CO Survey toward the Northern Region of the Small Magellanic Cloud with the Atacama Compact Array. I. Overview: CO Cloud Distributions" *The Astrophysical Journal*, 922 :171, 2021.
- Tollefson, Joshua; De Pater, Imke; Molter, Edward M.; Sault, Robert J.; Butler, Bryan J.; Luszcz-Cook, Stacia; Deboer, David "Neptune's Spatial Brightness Temperature Variations from the VLA and ALMA" *The*

- Planetary Science Journal, 2 :105, 2021.
- Tomar, Gunjan; Gupta, Nayantara; Prince, Raj "Broadband Modeling of Low-luminosity Active Galactic Nuclei Detected in Gamma Rays" The Astrophysical Journal, 919 :137, 2021.
- Torii, Kazufumi; Hattori, Yusuke; Matsuo, Mitsuhiro; Fujita, Shinji; Nishimura, Atsushi; Kohno, Mikito; Kuriki, Mika; Tsuda, Yuya; Minamidani, Tetsuhiro; Umemoto, Tomofumi; Kuno, Nario; Yoshiike, Satoshi; Ohama, Akio; Tachihara, Kengo; Fukui, Yasuo; Shima, Kazuhiro; Habe, Asao; Haworth, Thomas J. "CO observations of the molecular gas in the Galactic H II region Sh2-48: Evidence for cloud-cloud collision as a trigger of high-mass star formation" Publications of the Astronomical Society of Japan, 73 :S368, 2021.
- Torii, Kazufumi; Tokuda, Kazuki; Tachihara, Kengo; Onishi, Toshikazu; Fukui, Yasuo "ALMA view of the Galactic super star cluster RCW 38 at 270 au resolution" Publications of the Astronomical Society of Japan, 73 :205, 2021.
- Towner, A. P. M.; Brogan, C. L.; Hunter, T. R.; Cyganowski, C. J. "VLA Observations of Nine Extended Green Objects in the Milky Way: Ubiquitous Weak, Compact Continuum Emission, and Multi-epoch Emission from Methanol, Water, and Ammonia Masers" The Astrophysical Journal, 923 :263, 2021.
- Traas, Raffy; Croft, Steve; Gajjar, Vishal; Isaacson, Howard; Lebofsky, Matt; Macmahon, David H. E.; Perez, Karen; Price, Danny C.; Sheikh, Sofia; Siemion, Andrew P. V.; Smith, Shane; Drew, Jamie; Worden, S. Pete "The Breakthrough Listen Search for Intelligent Life: Searching for Technosignatures in Observations of TESS Targets of Interest" The Astronomical Journal, 161 :286, 2021.
- Tsuboi, Masato; Kitamura, Yoshimi; Uehara, Kenta; Miyawaki, Ryosuke; Tsutsumi, Takahiro; Miyazaki, Atsushi; Miyoshi, Makoto "Cloud-cloud collision in the Galactic Center Arc" Publications of the Astronomical Society of Japan, 73 :S91, 2021.
- Tsuge, Kiseitsu; Fukui, Yasuo; Tachihara, Kengo; Sano, Hidetoshi; Tokuda, Kazuki; Ueda, Junko; Iono, Daisuke; Finn, Molly K. "The formation of young massive clusters triggered by cloud-cloud collisions in the Antennae galaxies NGC 4038/NGC 4039" Publications of the Astronomical Society of Japan, 73 :S35, 2021.
- Tsuge, Kiseitsu; Tachihara, Kengo; Fukui, Yasuo; Sano, Hidetoshi; Tokuda, Kazuki; Ueda, Junko; Iono, Daisuke "The formation of the young massive cluster B1 in the Antennae Galaxies (NGC 4038/NGC 4039) triggered by cloud-cloud collision" Publications of the Astronomical Society of Japan, 73 :417, 2021.
- Tsukui, Takafumi; Iguchi, Satoru "Spiral morphology in an intensely star-forming disk galaxy more than 12 billion years ago" Science, 372 :1201, 2021.
- Tubín, Dusán; Treister, Ezequiel; D'Ago, Giuseppe; Venturi, Giacomo; Bauer, Franz E.; Privon, George C.; Koss, Michael J.; Ricci, Federica; Comerford, Julia M.; Müller-Sánchez, Francisco "The Complex Gaseous and Stellar Environments of the Nearby Dual Active Galactic Nucleus Mrk 739" The Astrophysical Journal, 911 :100, 2021.
- Turner, Jacob E.; Mclaughlin, Maura A.; Cordes, James M.; Lam, Michael T.; Shapiro-Albert, Brent J.; Stinebring, Daniel R.; Arzoumanian, Zaven; Blumer, Harsha; Brook, Paul R.; Chatterjee, Shami; Cromartie, H. Thankful; Decesar, Megan E.; Demorest, Paul B.; Dolch, Timothy; Ellis, Justin A.; Ferdman, Robert D.; Ferrara, Elizabeth C.; Fonseca, Emmanuel; Garver-Daniels, Nathan; Gentile, Peter A.; Good, Deborah C.; Jones, Megan L.; Lazio, T. Joseph W.; Lorimer, Duncan R.; Luo, Jing; Lynch, Ryan S.; Ng, Cherry; Nice, David J.; Pennucci, Timothy T.; Pol, Nihan S.; Ransom, Scott M.; Spiewak, Renée; Stairs, Ingrid H.; Stovall, Kevin; Swiggum, Joseph K.; Vigeland, Sarah J. "The NANOGrav 12.5 Year Data Set: Monitoring Interstellar Scattering Delays" The Astrophysical Journal, 917 :10, 2021.
- Tychoniec, Łukasz; Van Dishoeck, Ewine F.; Van'T Hoff, Merel L. R.; Van Gelder, Martijn L.; Tabone, Benoît; Chen, Yuan; Harsono, Daniel; Hull, Charles L. H.; Hogerheijde, Michiel R.; Murillo, Nadia M.; Tobin, John J. "Which molecule traces what: Chemical diagnostics of protostellar sources" Astronomy and Astrophysics, 655 :A65, 2021.
- Ubertosi, F.; Gitti, M.; Brighenti, F.; Brunetti, G.; McDonald, M.; Nulsen, P.; Mcnamara, B.; Randall, S.; Forman, W.; Donahue, M.; Ignesti, A.; Gaspari, M.; Ettori, S.; Feretti, L.; Blanton, E. L.; Jones, C.; Calzadilla, M. "The Deepest Chandra View of RBS 797: Evidence for Two Pairs of Equidistant X-ray Cavities" The Astrophysical Journal, 923 :L25, 2021.
- Ueda, Junko; Iono, Daisuke; Yun, Min S.; Michiyama, Tomonari; Watanabe, Yoshimasa; Snell, Ronald L.; Rosa-González, Daniel; Saito, Toshiki; Vega, Olga; Yamashita, Takuji "Cold Molecular Gas in Merger Remnants. II. The Properties of Dense Molecular Gas" The Astrophysical Journal Supplement Series, 257 :57, 2021.
- Ueda, Takahiro; Kataoka, Akimasa; Zhang, Shangjia; Zhu, Zhaohuan; Carrasco-González, Carlos; Sierra, Anibal "Impact of Differential Dust Settling on the SED and Polarization: Application to the Inner Region of the HL Tau Disk" The Astrophysical Journal, 913 :117, 2021.
- Umana, G.; Triggilio, C.; Ingallinera, A.; Riggi, S.; Cavallaro, F.; Marvil, J.; Norris, R. P.; Hopkins, A. M.; Buemi, C. S.; Bufano, F.; Leto, P.; Loru, S.; Bordiu, C.; Bunton, J. D.; Collier, J. D.; Filipovic, M.; Franzen, T. M. O.; Thompson, M. A.; Andernach, H.; Carretti, E.; Dai, S.; Kapińska, A.; Koribalski, B. S.; Kothes, R.; Leahy, D.; Mcconnell, D.; Tohill, N.; Michałowski, M. J. "A first glimpse at the Galactic Plane with the ASKAP: the SCORPIO field" Monthly Notices of the Royal Astronomical Society, 506 :2232, 2021.
- Umehata, Hideki; Smail, Ian; Steidel, Charles C.; Hayes, Matthew; Scott, Douglas; Swinbank, A. M.; Ivison, R. J.; Nagao, Toru; Kubo, Mariko; Nakanishi, Kouichiro; Matsuda, Yuichi; Ikarashi, Soh; Tamura, Yoichi; Geach, J. E. "ALMA Observations of Lya Blob 1: Multiple Major Mergers and Widely Distributed Interstellar Media" The Astrophysical Journal, 918 :69, 2021.
- Uno, Y.; Imai, H.; Shinano, K.; Qiao, H.-H.; Dawson, J. R.; Breen, S. L.; Gómez, J. F. "Modelled 3D distribution of OH/IR stars in the Galactic disc" Monthly Notices of the Royal Astronomical Society, 502 :3012, 2021.
- Ushio, Kaito; Ohta, Kouji; Maeda, Fumiya; Hatsukade, Bunyo; Yabe, Kiyoto "Internal Structure of Molecular Gas in a Main-sequence Galaxy With a UV Clump at  $z = 1.45$ " The Astrophysical Journal, 909 :84, 2021.
- Uzgil, Bade D.; Oesch, Pascal A.; Walter, Fabian; Aravena, Manuel; Boogaard, Leindert; Carilli, Chris; Decarli, Roberto; Díaz-Santos, Tanio; Fudamoto, Yoshi; Inami, Hanae; Bouwens, Rychard; Cortes, Paulo C.; Cox, Pierre; Daddi, Emmanuele; González-López, Jorge; Labbe, Ivo; Popping, Gergö; Riechers, Dominik; Stefanon, Mauro; Van Der Werf, Paul; Weiss, Axel "The ALMA Spectroscopic Survey in the HUDF: A Search for [C II] Emitters at  $6 \leq z \leq 8$ " The Astrophysical Journal, 912 :67, 2021.
- Valentino, F.; Daddi, E.; Puglisi, A.; Magdis, G. E.; Kokorev, I.; Liu, D.; Madden, S. C.; Gómez-Guijarro, C.; Lee, M.-Y.; Cortzen, I.; Circosta, C.; Delvecchio, I.; Mullaney, J. R.; Gao, Y.; Gobat, R.; Aravena, M.; Jin, S.; Fujimoto, S.; Silverman, J. D.; Dannerbauer, H. "The effect of active galactic nuclei on the cold interstellar medium in distant star-forming galaxies" Astronomy and Astrophysics, 654 :A165, 2021.
- Valle Silva, J. F.; Giménez De Castro, C. G.; Selhorst, C. L.; Raulin, J. P.; Valio, A. "Spectral Signature of Solar Active Region in Millimeter and Submillimeter Wavelengths" Monthly Notices of the Royal Astronomical Society, 500 :1964, 2021.
- Van Den Eijnden, J.; Degenaar, N.; Russell, T. D.; Wijnands, R.; Bahramian, A.; Miller-Jones, J. C. A.; Hernández Santisteban, J. V.; Gallo, E.; Atri, P.; Plotkin, R. M.; Maccarone, T. J.; Sivakoff, G.; Miller, J. M.; Reynolds, M.; Russell, D. M.; Maitra, D.; Heinke, C. O.; Armas Padilla, M.; Shaw, A. W. "A new radio census of neutron star X-ray binaries" Monthly Notices of the Royal Astronomical Society, 507 :3899, 2021.
- Van Der Marel, Nienke; Birnstiel, Til; Garufi, Antonio; Ragusa, Enrico; Christiaens, Valentin; Price, Daniel J.; Sallum, Steph; Muley, Dhruv; Francis, Logan; Dong, Ruobing "On the Diversity of Asymmetries in Gapped Protoplanetary Disks" The Astronomical Journal, 161 :33, 2021.
- Van Der Marel, Nienke; Booth, Alice S.; Leemker, Margot; Van Dishoeck, Ewine F.; Ohashi, Satoshi "A major asymmetric ice trap in a planet-forming disk. I. Formaldehyde and methanol" Astronomy and

## APPENDIX A: PUBLICATIONS

- Astrophysics, 651 :L5, 2021.
- Van Der Marel, Nienke; Bosman, Arthur D.; Krijt, Sebastiaan; Mulders, Gijs D.; Bergner, Jennifer B. "If you like C/O variations, you should have put a ring on it" *Astronomy and Astrophysics*, 653 :L9, 2021.
- Van Der Marel, Nienke; Mulders, Gijs D. "A Stellar Mass Dependence of Structured Disks: A Possible Link with Exoplanet Demographics" *The Astronomical Journal*, 162 :28, 2021.
- Van Der Vlugt, D.; Algera, H. S. B.; Hodge, J. A.; Novak, M.; Radcliffe, J. F.; Riechers, D. A.; Röttgering, H.; Smolčić, V.; Walter, F. "An Ultradeep Multiband VLA Survey of the Faint Radio Sky (COSMOS-XS): Source Catalog and Number Counts" *The Astrophysical Journal*, 907 :5, 2021.
- Vantygghem, A. N.; Mcnamara, B. R.; O'Dea, C. P.; Baum, S. A.; Combes, F.; Edge, A. C.; Fabian, A. C.; McDonald, M.; Nulsen, P. E. J.; Russell, H. R.; Salomé, P. "A Massive, Clumpy Molecular Gas Distribution and Displaced AGN in Zw 3146" *The Astrophysical Journal*, 910 :53, 2021.
- Vardoulaki, E.; Jiménez Andrade, E. F.; Delvecchio, I.; Smolčić, V.; Schinnerer, E.; Sargent, M. T.; Gozaliasl, G.; Finoguenov, A.; Bondi, M.; Zamorani, G.; Badescu, T.; Leslie, S. K.; Ceraj, L.; Tisanić, K.; Karim, A.; Magnelli, B.; Bertoldi, F.; Romano-Díaz, E.; Harrington, K. "FR-type radio sources at 3 GHz VLA-COSMOS: Relation to physical properties and large-scale environment" *Astronomy and Astrophysics*, 648 :A102, 2021.
- Vardoulaki, Eleni; Vazza, Franco; Jiménez-Andrade, Eric F.; Gozaliasl, Ghassem; Finoguenov, Alexis; Wittor, Denis "Bent Like FRs: Extended Radio AGN in the COSMOS Field and Their Large-Scale Environment" *Galaxies*, 9 :93, 2021.
- Vargas-González, J.; Forbrich, J.; Dzib, S. A.; Bally, J. "From downtown to the outskirts: a radio survey of the Orion Nebula Cluster" *Monthly Notices of the Royal Astronomical Society*, 506 :3169, 2021.
- Vaskonen, Ville; Veermäe, Hardi "Did NANOGrav See a Signal from Primordial Black Hole Formation?" *Physical Review Letters*, 126 :51303, 2021.
- Vayner, Andrey; Zakamska, Nadia; Wright, Shelley A.; Armus, Lee; Murray, Norman; Walth, Gregory "Multiphase Outflows in High-redshift Quasar Host Galaxies" *The Astrophysical Journal*, 923 :59, 2021.
- Vazzano, M. M.; Fernández-López, M.; Plunkett, A.; De Gregorio-Monsalvo, I.; Santamaría-Miranda, A.; Takahashi, S.; Lopez, C. "Outflows, envelopes, and disks as evolutionary indicators in Lupus young stellar objects" *Astronomy and Astrophysics*, 648 :A41, 2021.
- Veronesi, Benedetta; Paneque-Carreño, Teresa; Lodato, Giuseppe; Testi, Leonardo; Pérez, Laura M.; Bertin, Giuseppe; Hall, Cassandra "A Dynamical Measurement of the Disk Mass in Elias 227" *The Astrophysical Journal*, 914 :L27, 2021.
- Vidal-García, A.; Falgarone, E.; Arrigoni Battaia, F.; Godard, B.; Ivison, R. J.; Zwaan, M. A.; Herrera, C.; Frayer, D.; Andreani, P.; Li, Q.; Gavazzi, R. "Where infall meets outflows: turbulent dissipation probed by CH<sup>+</sup> and Ly $\alpha$  in the starburst/AGN galaxy group SMM J02399-0136 at z 2.8" *Monthly Notices of the Royal Astronomical Society*, 506 :2551, 2021.
- Villanueva, G. L.; Cordiner, M.; Irwin, P. G. J.; De Pater, I.; Butler, B.; Gurwell, M.; Milam, S. N.; Nixon, C. A.; Luszczyk-Cook, S. H.; Wilson, C. F.; Kofman, V.; Liuzzi, G.; Faggi, S.; Faucher, T. J.; Lippi, M.; Cosentino, R.; Thelen, A. E.; Moullet, A.; Hartogh, P.; Molter, E. M.; Charnley, S.; Arney, G. N.; Mandell, A. M.; Biver, N.; Vandaele, A. C.; De Kleer, K. R.; Koppappu, R. "No evidence of phosphine in the atmosphere of Venus from independent analyses" *Nature Astronomy*, 5 :631, 2021.
- Villar Martín, M.; Emons, B. H. C.; Cabrera Lavers, A.; Bellocchi, E.; Alonso Herrero, A.; Humphrey, A.; Dall'Agnol De Oliveira, B.; Storchi-Bergmann, T. "Interactions between large-scale radio structures and gas in a sample of optically selected type 2 quasars" *Astronomy and Astrophysics*, 650 :A84, 2021.
- Villeneuve, M.; Ménard, F.; Dent, W. R. F.; Benisty, M.; Van Der Plas, G.; Williams, J. P.; Ansdell, M.; Ribas, Á.; Cáceres, C.; Canovas, H.; Cieza, L.; Hales, A.; Kamp, I.; Pinte, C.; Principe, D. A.; Schreiber, M. R. "Probing protoplanetary disk evolution in the Chamaeleon II region" *Astronomy and Astrophysics*, 653 :A46, 2021.
- Vlemmings, W. H. T.; Khouri, T.; Tafaya, D. "Maser emission from the CO envelope of the asymptotic giant branch star W Hydrae" *Astronomy and Astrophysics*, 654 :A18, 2021.
- Vrublevskis, A.; Ryabov, B. I.; White, S. M. "Reduced Microwave Brightness Temperature in a Sunspot Atmosphere Due to Open Magnetic Fields" *Solar Physics*, 296 :144, 2021.
- Walker, Daniel L.; Longmore, Steven N.; Bally, John; Ginsburg, Adam; Kruijssen, J. M. Diederik; Zhang, Qizhou; Henshaw, Jonathan D.; Lu, Xing; Alves, João; Barnes, Ashley T.; Battersby, Cara; Beuther, Henrik; Contreras, Yanett A.; Gómez, Laura; Ho, Luis C.; Jackson, James M.; Kauffmann, Jens; Mills, Elisabeth A. C.; Pillai, Thushara "Star formation in 'the Brick': ALMA reveals an active protocluster in the Galactic centre cloud G0.253+0.016" *Monthly Notices of the Royal Astronomical Society*, 503 :77, 2021.
- Wallace, John; Pe'er, Asaf "An Observational Signature of Sub-equipartition Magnetic Fields in the Spectra of Black Hole Binaries" *The Astrophysical Journal*, 916 :63, 2021.
- Wang, Ailing; An, Tao; Jaiswal, Sumit; Mohan, Prashanth; Wang, Yuchan; Baan, Willem A.; Zhang, Yingkang; Yang, Xiaolong "The obstructed jet in Mrk 231" *Monthly Notices of the Royal Astronomical Society*, 504 :3823, 2021.
- Wang, F. Y.; Zhang, G. Q.; Dai, Z. G. "Galactic and cosmological fast radio bursts as scaled-up solar radio bursts" *Monthly Notices of the Royal Astronomical Society*, 501 :3155, 2021.
- Wang, Feige; Fan, Xiaohui; Yang, Jinyi; Mazzucchelli, Chiara; Wu, Xue-Bing; Li, Jiang-Tao; Bañados, Eduardo; Farina, Emanuele Paolo; Nanni, Riccardo; Ai, Yanli; Bian, Fuyan; Davies, Frederick B.; Decarli, Roberto; Hennawi, Joseph F.; Schindler, Jan-Torge; Venemans, Bram; Walter, Fabian "Revealing the Accretion Physics of Supermassive Black Holes at Redshift z  $\sim$  7 with Chandra and Infrared Observations" *The Astrophysical Journal*, 908 :53, 2021.
- Wang, Feige; Yang, Jinyi; Fan, Xiaohui; Hennawi, Joseph F.; Barth, Aaron J.; Banados, Eduardo; Bian, Fuyan; Boutsia, Konstantina; Connor, Thomas; Davies, Frederick B.; Decarli, Roberto; Eilers, Anna-Christina; Farina, Emanuele Paolo; Green, Richard; Jiang, Linhua; Li, Jiang-Tao; Mazzucchelli, Chiara; Nanni, Riccardo; Schindler, Jan-Torge; Venemans, Bram; Walter, Fabian; Wu, Xue-Bing; Yue, Minghao "A Luminous Quasar at Redshift 7.642" *The Astrophysical Journal*, 907 :L1, 2021.
- Wang, J. Z.; Liu, S.; Zhang, Z.-Y.; Shi, Y. "HCN (1-0) opacity of outflowing gas in Arp 220W" *Astronomy and Astrophysics*, 649 :A125, 2021.
- Wang, Yuanming; Tuntsov, Artem; Murphy, Tara; Lenc, Emil; Walker, Mark; Bannister, Keith; Kaplan, David L.; Mahony, Elizabeth K. "ASKAP observations of multiple rapid scintillators reveal a degrees-long plasma filament" *Monthly Notices of the Royal Astronomical Society*, 502 :3294, 2021.
- Ward-Duong, K.; Patience, J.; Follette, K.; De Rosa, R. J.; Rameau, J.; Marley, M.; Saumon, D.; Nielsen, E. L.; Rajan, A.; Greenbaum, A. Z.; Lee, J.; Wang, J. J.; Czekala, I.; Duchêne, G.; Macintosh, B.; Ammons, S. Mark; Bailey, V. P.; Barman, T.; Bulger, J.; Chen, C.; Chilcote, J.; Cotten, T.; Doyon, R.; Esposito, T. M.; Fitzgerald, M. P.; Gerard, B. L.; Goodsell, S. J.; Graham, J. R.; Hiben, P.; Hom, J.; Hung, L.-W.; Ingraham, P.; Kalas, P.; Konopacky, Q.; Larkin, J. E.; Maire, J.; Marchis, F.; Marois, C.; Metchev, S.; Millar-Blanchaer, M. A.; Oppenheimer, R.; Palmer, D.; Perrin, M.; Poyneer, L.; Pueyo, L.; Rantakyro, F. T.; Ren, B.; Ruffio, J.-B.; Savransky, D.; Schneider, A. C.; Sivaramakrishnan, A.; Song, I.; Soummer, R.; Tallis, M.; Thomas, S.; Wallace, J. Kent; Wiktorowicz, S.; Wolff, S. "Gemini Planet Imager Spectroscopy of the Dusty Substellar Companion HD 206893 B" *The Astronomical Journal*, 161 :5, 2021.
- Webster, B.; Croston, J. H.; Harwood, J. J.; Baldi, R. D.; Hardcastle, M. J.; Mingo, B.; Röttgering, H. J. A. "Investigating the spectra and physical nature of galaxy scale jets" *Monthly Notices of the Royal Astronomical Society*, 508 :5972, 2021.
- Webster, B.; Croston, J. H.; Mingo, B.; Baldi, R. D.; Barkus, B.; Gürkan, G.; Hardcastle, M. J.; Morganti, R.; Röttgering, H. J. A.; Sabater, J.; Shimwell, T. W.; Tasse, C.; White, G. J. "A population of galaxy-scale jets discovered using LOFAR" *Monthly Notices of the Royal Astronomical*

- Society, 500 :4921, 2021.
- Wenger, Trey V.; Dawson, J. R.; Dickey, John M.; Jordan, C. H.; McClure-Griffiths, N. M.; Anderson, L. D.; Armentrout, W. P.; Balsler, Dana S.; Bania, T. M. "The Southern H II Region Discovery Survey. II. The Full Catalog" *The Astrophysical Journal Supplement Series*, 254 :36, 2021.
- Whitaker, Katherine E.; Narayanan, Desika; Williams, Christina C.; Li, Qi; Spilker, Justin S.; Davé, Romeel; Akhshik, Mohammad; Akins, Hollis B.; Bezanson, Rachel; Katz, Neal; Leja, Joel; Magdis, Georgios E.; Mowla, Lamiya; Nelson, Erica J.; Pope, Alexandra; Privon, George C.; Toft, Sune; Valentino, Francesco "High Molecular-gas to Dust Mass Ratios Predicted in Most Quiescent Galaxies" *The Astrophysical Journal*, 922 :L30, 2021.
- Whitaker, Katherine E.; Williams, Christina C.; Mowla, Lamiya; Spilker, Justin S.; Toft, Sune; Narayanan, Desika; Pope, Alexandra; Magdis, Georgios E.; Van Dokkum, Pieter G.; Akhshik, Mohammad; Bezanson, Rachel; Brammer, Gabriel B.; Leja, Joel; Man, Allison; Nelson, Erica J.; Richard, Johan; Pacifici, Camilla; Sharon, Keren; Valentino, Francesco "Quenching of star formation from a lack of inflowing gas to galaxies" *Nature*, 597 :485, 2021.
- White, Jacob Aaron; Tapia-Vázquez, F.; Hughes, A. G.; Moór, A.; Matthews, B.; Wilner, D.; Aufdenberg, J.; Fehér, O.; Hughes, A. M.; De La Luz, V.; Mcnaughton, A.; Zapata, L. A. "The First Radio Spectrum of a Rapidly Rotating A-type Star" *The Astrophysical Journal*, 912 :L5, 2021.
- Williams, Christina C.; Spilker, Justin S.; Whitaker, Katherine E.; Davé, Romeel; Woodrum, Charity; Brammer, Gabriel; Bezanson, Rachel; Narayanan, Desika; Weiner, Benjamin "ALMA Measures Rapidly Depleted Molecular Gas Reservoirs in Massive Quiescent Galaxies at  $z \sim 1.5$ " *The Astrophysical Journal*, 908 :54, 2021.
- Williams, Thomas G.; Schinnerer, Eva; Emsellem, Eric; Meidt, Sharon; Querejeta, Miguel; Belfiore, Francesco; Bešlić, Ivana; Bigiel, Frank; Chevance, Mélanie; Dale, Daniel A.; Glover, Simon C. O.; Grasha, Kathryn; Klessen, Ralf S.; Kruijssen, J. M. Diederik; Leroy, Adam K.; Pan, Hsi-An; Pety, Jérôme; Pessa, Ismael; Rosolowsky, Erik; Saito, Toshiki; Santoro, Francesco; Schrubba, Andreas; Sormani, Mattia C.; Sun, Jiayi; Watkins, Elizabeth J. "Applying the Tremaine-Weinberg Method to Nearby Galaxies: Stellar-mass-based Pattern Speeds and Comparisons with ISM Kinematics" *The Astronomical Journal*, 161 :185, 2021.
- Witzel, G.; Martinez, G.; Willner, S. P.; Becklin, E. E.; Boyce, H.; Do, T.; Eckart, A.; Fazio, G. G.; Ghez, A.; Gurwell, M. A.; Haggard, D.; Herrero-Illana, R.; Hora, J. L.; Li, Z.; Liu, J.; Marchili, N.; Morris, Mark R.; Smith, Howard A.; Subroweit, M.; Zensus, J. A. "Rapid Variability of Sgr A\* across the Electromagnetic Spectrum" *The Astrophysical Journal*, 917 :73, 2021.
- Wolff, Michael T.; Guillot, Sebastien; Bogdanov, Slavko; Ray, Paul S.; Kerr, Matthew; Arzoumanian, Zaven; Gendreau, Keith C.; Miller, M. Coleman; Dittmann, Alexander J.; Ho, Wynn C. G.; Guillemot, Lucas; Cognard, Ismael; Theureau, Gilles; Wood, Kent S. "NICER Detection of Thermal X-Ray Pulsations from the Massive Millisecond Pulsars PSR J0740+6620 and PSR J1614-2230" *The Astrophysical Journal*, 918 :L26, 2021.
- Wolff, Schuyler G.; Duchêne, Gaspard; Stapelfeldt, Karl R.; Ménard, Francois; Flores, Christian; Padgett, Deborah; Pinte, Christophe; Villenave, Marion; Van Der Plas, Gerrit; Perrin, Marshall D. "The Anatomy of an Unusual Edge-on Protoplanetary Disk. I. Dust Settling in a Cold Disk" *The Astronomical Journal*, 161 :238, 2021.
- Wołowska, Aleksandra; Kunert-Bajraszewska, Magdalena; Mooley, Kunal P.; Siemiginowska, Aneta; Kharb, Preeti; Ishwara-Chandra, C. H.; Hallinan, Gregg; Gromadzki, Mariusz; Koziel-Wierzbowska, Dorota "Caltech-NRAO Stripe 82 Survey (CNSS). V. AGNs That Transitioned to Radio-loud State" *The Astrophysical Journal*, 914 :22, 2021.
- Wood, C. M.; Miller-Jones, J. C. A.; Homan, J.; Bright, J. S.; Motta, S. E.; Fender, R. P.; Markoff, S.; Belloni, T. M.; Körding, E. G.; Maitra, D.; Migliari, S.; Russell, D. M.; Russell, T. D.; Sarazin, C. L.; Soria, R.; Tetarenko, A. J.; Tudose, V. "The varying kinematics of multiple ejecta from the black hole X-ray binary MAXI J1820 + 070" *Monthly Notices of the Royal Astronomical Society*, 505 :3393, 2021.
- Wrobel, J. M.; Maccarone, T. J.; Miller-Jones, J. C. A.; Nyland, K. E. "Accessing Intermediate-mass Black Holes in 728 Globular Star Clusters in NGC 4472" *The Astrophysical Journal*, 918 :18, 2021.
- Wu, Yunjing; Cai, Zheng; Neeleman, Marcel; Finlator, Kristian; Zhang, Shiwu; Prochaska, J. Xavier; Wang, Ran; Emonts, Bjorn H. C.; Fan, Xiaohui; Keating, Laura C.; Wang, Feige; Yang, Jinyi; Hennawi, Joseph F.; Wang, Junxian "A [C II] 158  $\mu\text{m}$  emitter associated with an O I absorber at the end of the reionization epoch" *Nature Astronomy*, 5 :1110-1117, 2021.
- Wu, Yu-Ting; Trejo, Alfonso; Espada, Daniel; Miyamoto, Yusuke "Morphological and kinematical analysis of the double-barred galaxy NGC 3504 using ALMA CO (2-1) data" *Monthly Notices of the Royal Astronomical Society*, 504 :3111, 2021.
- Xiang, Katherine M.; Nataf, David M.; Athanassoula, E.; Zakamska, Nadia L.; Rowlands, Kate; Masters, Karen; Fraser-McKelvie, Amelia; Drory, Niv; Kraljic, Katarina "Buckling Bars in Nearly Face-on Galaxies Observed with MaNGA" *The Astrophysical Journal*, 909 :125, 2021.
- Xu, Qian; Gong, Bi-Ping; Liu, Meng-Xu; Lu, Ru-Sen; Yan, Xi; Dong, Shi-Yin "Understanding the Puzzling Acceleration of Jets of Active Galactic Nuclei" *The Astrophysical Journal Supplement Series*, 252 :25, 2021.
- Xu, Y.; Bian, S. B.; Reid, M. J.; Li, J. J.; Menten, K. M.; Dame, T. M.; Zhang, B.; Brunthaler, A.; Wu, Y. W.; Moscadelli, L.; Wu, G.; Zheng, X. W. "Trigonometric Parallaxes of Four Star-forming Regions in the Distant Inner Galaxy" *The Astrophysical Journal Supplement Series*, 253 :1, 2021.
- Yadlapalli, Nitika; Ravi, Vikram; Yao, Yuhang; Kulkarni, S. R.; Brisken, Walter "VLBA Discovery of a Resolved Source in the Candidate Black Hole X-Ray Binary AT2019wey" *The Astrophysical Journal*, 909 :L27, 2021.
- Yamada, Satoshi; Ueda, Yoshihiro; Tanimoto, Atsushi; Imanishi, Masatoshi; Toba, Yoshiki; Ricci, Claudio; Privon, George C. "Comprehensive Broadband X-Ray and Multiwavelength Study of Active Galactic Nuclei in 57 Local Luminous and Ultraluminous Infrared Galaxies Observed with NuSTAR and/or Swift/BAT" *The Astrophysical Journal Supplement Series*, 257 :61, 2021.
- Yamagishi, Mitsuyoshi; Shimajiri, Yoshito; Tokuda, Kazuki; Kawabe, Ryohei; Nakamura, Fumitaka; Kamazaki, Takeshi; Nomura, Hideko; Takekoshi, Tatsuya "ALMA View of the  $\rho$  Ophiuchi A PDR with a 360 au Beam: The [C I] Emission Originates from the Plane-parallel PDR and Extended Gas" *The Astrophysical Journal*, 914 :L9, 2021.
- Yamaguchi, Masayuki; Tsukagoshi, Takashi; Muto, Takayuki; Nomura, Hideko; Nakazato, Takeshi; Ikeda, Shiro; Tamura, Motohide; Kawabe, Ryohei "ALMA Super-resolution Imaging of T Tau:  $r = 12$  au Gap in the Compact Dust Disk around T Tau N" *The Astrophysical Journal*, 923 :121, 2021.
- Yamane, Y.; Sano, H.; Filipović, M. D.; Tokuda, K.; Fujii, K.; Babazaki, Y.; Mitsuishi, I.; Inoue, T.; Aharonian, F.; Inaba, T.; Inutsuka, S.; Maxted, N.; Mizuno, N.; Onishi, T.; Rowell, G.; Tsuge, K.; Voisin, F.; Yoshiike, S.; Fukuda, T.; Kawamura, A.; Bamba, A.; Tachihara, K.; Fukui, Y. "Associated Molecular and Atomic Clouds with X-Ray Shell of Superbubble 30 Doradus C in the LMC" *The Astrophysical Journal*, 918 :36, 2021.
- Yan, Zhen; Pan, Zhi-Chen; Ransom, Scott M.; Lorimer, Duncan R.; Qian, Lei; Wang, Pei; Shen, Zhi-Qiang; Li, Di; Jiang, Peng; Luo, Jin-Tao; Liu, Jie; Huang, Zhi-Peng "An Eclipsing Black Widow Pulsar in NGC 6712" *The Astrophysical Journal*, 921 :120, 2021.
- Yang, A. Y.; Urquhart, J. S.; Thompson, M. A.; Menten, K. M.; Wyrowski, F.; Brunthaler, A.; Tian, W. W.; Rugel, M.; Yang, X. L.; Yao, S.; Mutale, M. "A population of hypercompact H II regions identified from young H II regions" *Astronomy and Astrophysics*, 645 :A110, 2021.
- Yang, Bin; Li, Aigen; Cordiner, Martin A.; Chang, Chin-Shin; Hainaut, Olivier R.; Williams, Jonathan P.; Meech, Karen J.; Keane, Jacqueline V.; Villard, Eric "Compact pebbles and the evolution of volatiles in the interstellar comet 2I/Borisov" *Nature Astronomy*, 5 :586, 2021.
- Yang, Jun; Paragi, Zsolt; Beswick, Robert J.; Chen, Wen; Van Bemmell, Ilse M.; Wu, Qingwen; An, Tao; Wu, Xiaocong; Fan, Lulu; Oonk, J. B. R.; Liu, Xiang; Wang, Weihua "A compact core-jet structure in the changing-

## APPENDIX A: PUBLICATIONS

- look Seyfert NGC 2617" *Monthly Notices of the Royal Astronomical Society*, 503 :3886, 2021.
- Yang, Yao-Lun; Sakai, Nami; Zhang, Yichen; Murillo, Nadia M.; Zhang, Ziwei E.; Higuchi, Aya E.; Zeng, Shaoshan; López-Sepulcre, Ana; Yamamoto, Satoshi; Lefloch, Bertrand; Bouvier, Mathilde; Ceccarelli, Cecilia; Hirota, Tomoya; Imai, Muneaki; Oya, Yoko; Sakai, Takeshi; Watanabe, Yoshimasa "The Perseus ALMA Chemistry Survey (PEACHES). I. The Complex Organic Molecules in Perseus Embedded Protostars" *The Astrophysical Journal*, 910 :20, 2021.
- Yao, Su; Komossa, S. "Spectroscopic classification, variability, and SED of the Fermi-detected CSS 3C 286: the radio-loudest NLS1 galaxy?" *Monthly Notices of the Royal Astronomical Society*, 501 :1384, 2021.
- Yao, Su; Yang, Xiaolong; Gu, Minfeng; An, Tao; Yang, Jun; Ho, Luis C.; Liu, Xiang; Wang, Ran; Wu, Xue-Bing; Yuan, Weimin "Detection of a parsec-scale jet in a radio-quiet narrow-line Seyfert 1 galaxy with highly accreting supermassive black hole" *Monthly Notices of the Royal Astronomical Society*, 508 :1305, 2021.
- Yao, Yuhang; Kulkarni, S. R.; Burdge, Kevin B.; Caiazzo, Ilaria; De, Kishalay; Dong, Dillon; Fremling, C.; Kasliwal, Mansi M.; Kupfer, Thomas; Van Roestel, Jan; Sollerman, Jesper; Bagdasaryan, Ashot; Bellm, Eric C.; Cenko, S. Bradley; Drake, Andrew J.; Duev, Dmitry A.; Graham, Matthew J.; Kaye, Stephen; Masci, Frank J.; Miranda, Nicolas; Prince, Thomas A.; Riddle, Reed; Rusholme, Ben; Soumagnac, Maayane T. "Multi-wavelength Observations of AT2019wey: a New Candidate Black Hole Low-mass X-ray Binary" *The Astrophysical Journal*, 920 :120, 2021.
- Yen, Hsi-Wei; Zhao, Bo; Koch, Patrick M.; Gupta, Aashish "No Impact of Core-scale Magnetic Field, Turbulence, or Velocity Gradient on Sizes of Protostellar Disks in Orion A" *The Astrophysical Journal*, 916 :97, 2021.
- Yonemaru, N.; Kuroyanagi, S.; Hobbs, G.; Takahashi, K.; Zhu, X.-J.; Coles, W. A.; Dai, S.; Howard, E.; Manchester, R.; Reardon, D.; Russell, C.; Shannon, R.; Thyagarajan, N.; Spiewak, R.; Wang, J.-B. "Searching for gravitational wave bursts from cosmic string cusps with the Parkes Pulsar Timing Array" *Monthly Notices of the Royal Astronomical Society*, 501 :701, 2021.
- Young, Lisa M.; Meier, David S.; Bureau, Martin; Crocker, Alison; Davis, Timothy A.; Topal, Selçuk "The Evolution of NGC 7465 as Revealed by Its Molecular Gas Properties" *The Astrophysical Journal*, 909 :98, 2021.
- Youngblood, Allison; Roberge, Aki; Macgregor, Meredith A.; Brandeker, Alexis; Weinberger, Alycia J.; Pérez, Sebastián; Grady, Carol; Welsh, Barry "A Radiatively Driven Wind from the  $\eta$  Tel Debris Disk" *The Astronomical Journal*, 162 :235, 2021.
- Yu, Haochuan; Teague, Richard; Bae, Jaehan; Öberg, Karin "Mapping the 3D Kinematical Structure of the Gas Disk of HD 169142" *The Astrophysical Journal*, 920 :L33, 2021.
- Yue, Minghao; Yang, Jinyi; Fan, Xiaohui; Wang, Feige; Spilker, Justin; Georgiev, Iskren Y.; Keeton, Charles R.; Litke, Katrina C.; Marrone, Daniel P.; Walter, Fabian; Wang, Ran; Wu, Xue-Bing; Venemans, Bram P.; Zabludoff, Ann "ALMA Observations of the Sub-kpc Structure of the Host Galaxy of a  $z = 6.5$  Lensed Quasar: A Rotationally Supported Hyper-Starburst System at the Epoch of Reionization" *The Astrophysical Journal*, 917 :99, 2021.
- Yue, Nan-Nan; Li, Di; Zhang, Qi-Zhou; Zhu, Lei; Henshaw, Jonathan; Mardones, Diego; Ren, Zhi-Yuan "Resolution-dependent subsonic non-thermal line dispersion revealed by ALMA" *Research in Astronomy and Astrophysics*, 21 :24, 2021.
- Yusef-Zadeh, F.; Wardle, M.; Heinke, C.; Heywood, I.; Arendt, R.; Royster, M.; Cotton, W.; Camilo, F.; Michail, J. "G0.173-0.42: an X-ray and radio magnetized filament near the galactic center" *Monthly Notices of the Royal Astronomical Society*, 500 :3142, 2021.
- Zabel, Nikki; Davis, Timothy A.; Smith, Matthew W. L.; Sarzi, Marc; Loni, Alessandro; Serra, Paolo; Lara-López, Maritza A.; Cigan, Phil; Baes, Maarten; Bendo, George J.; De Looze, Ilse; Iodice, Enrichetta; Kleiner, Dane; Koribalski, Bärbel S.; Peletier, Reynier; Pinna, Francesca; De Zeeuw, P. Tim "AlFoCS + F3D - II. Unexpectedly low gas-to-dust ratios in the Fornax galaxy cluster" *Monthly Notices of the Royal Astronomical Society*, 502 :4723, 2021.
- Zahorec, S.; Jimenez-Serra, I.; Testi, L.; Immer, K.; Fontani, F.; Caselli, P.; Wang, K.; Onishi, T. "Singly and doubly deuterated formaldehyde in massive star-forming regions" *Astronomy and Astrophysics*, 653 :A45, 2021.
- Zamponi, Joaquin; Maureira, María José; Zhao, Bo; Liu, Hanyu Baobab; Ilee, John D.; Forgan, Duncan; Caselli, Paola "The young protostellar disc in IRAS 16293-2422 B is hot and shows signatures of gravitational instability" *Monthly Notices of the Royal Astronomical Society*, 508 :2583, 2021.
- Zanchettin, M. V.; Feruglio, C.; Bischetti, M.; Malizia, A.; Molina, M.; Bongiorno, A.; Dadina, M.; Gruppioni, C.; Piconcelli, E.; Tombesi, F.; Travascio, A.; Fiore, F. "The IBISCO survey. I. Multiphase discs and winds in the Seyfert galaxy Markarian 509" *Astronomy and Astrophysics*, 655 :A25, 2021.
- Zavala, J. A.; Casey, C. M.; Manning, S. M.; Aravena, M.; Bethermin, M.; Caputi, K. I.; Clements, D. L.; Cunha, E. Da; Drew, P.; Finkelstein, S. L.; Fujimoto, S.; Hayward, C.; Hodge, J.; Kartaltepe, J. S.; Knudsen, K.; Koekemoer, A. M.; Long, A. S.; Magdis, G. E.; Man, A. W. S.; Popping, G.; Sanders, D.; Scoville, N.; Sheth, K.; Staguhn, J.; Toft, S.; Treister, E.; Vieira, J. D.; Yun, M. S. "The Evolution of the IR Luminosity Function and Dust-obscured Star Formation over the Past 13 Billion Years" *The Astrophysical Journal*, 909 :165, 2021.
- Zhang, Chuan-Peng; Launhardt, Ralf; Liu, Yao; Tobin, John J.; Henning, Thomas "Pebbles in an embedded protostellar disk: the case of CB 26" *Astronomy and Astrophysics*, 646 :A18, 2021.
- Zhang, K.; Zhang, Z. B.; Huang, Y. F.; Song, L. M.; Zheng, S. J.; Li, X. J.; Li, D.; Su, F. F. "How are gamma-ray burst radio afterglows populated?" *Monthly Notices of the Royal Astronomical Society*, 503 :3262, 2021.
- Zhang, Ke; Booth, Alice S.; Law, Charles J.; Bosman, Arthur D.; Schwarz, Kamber R.; Bergin, Edwin A.; Öberg, Karin I.; Andrews, Sean M.; Guzmán, Viviana V.; Walsh, Catherine; Qi, Chunhua; Van'T Hoff, Merel L. R.; Long, Feng; Wilner, David J.; Huang, Jane; Czekala, Ian; Ilee, John D.; Cataldi, Gianni; Bergner, Jennifer B.; Aikawa, Yuri; Teague, Richard; Bae, Jaehan; Loomis, Ryan A.; Calahan, Jenny K.; Alarcón, Felipe; Ménard, François; Le Gal, Romane; Sierra, Anibal; Yamato, Yoshihide; Nomura, Hideko; Tsukagoshi, Takashi; Pérez, Laura M.; Trapman, Leon; Liu, Yao; Furuya, Kenji "Molecules with ALMA at Planet-forming Scales (MAPS). V. CO Gas Distributions" *The Astrophysical Journal Supplement Series*, 257 :5, 2021.
- Zhang, S.; Zavagno, A.; López-Sepulcre, A.; Liu, H.; Louvet, F.; Figueira, M.; Russeil, D.; Wu, Y.; Yuan, J.; Pillai, T. G. S. "H II regions and high-mass starless clump candidates. II. Fragmentation and induced star formation at 0.025 pc scale: an ALMA continuum study" *Astronomy and Astrophysics*, 646 :A25, 2021.
- Zhang, X.; Simionescu, A.; Stuardi, C.; Van Weeren, R. J.; Intema, H. T.; Akamatsu, H.; De Plaa, J.; Kaastra, J. S.; Bonafede, A.; Brüggen, M.; Zuhone, J.; Ichinohe, Y. "Deep Chandra observations of merging galaxy cluster ZwCl 2341+0000" *Astronomy and Astrophysics*, 656 :A59, 2021.
- Zhang, Y.; Bastian, T. S.; Liu, J. H.; Yu, S. J.; Feng, S.; Chen, J.; Yan, Y. H. "Multiwavelength Observations of the Formation and Eruption of a Complex Filament" *The Astrophysical Journal*, 910 :40, 2021.
- Zhang, Yingkang; An, Tao; Frey, Sándor; Yang, Xiaolong; Krezinger, Máté; Titov, Oleg; Melnikov, Alexey; De Vicente, Pablo; Shu, Fengchun; Wang, Ailing "J2102+6015: a young radio source at  $z = 4.575$ " *Monthly Notices of the Royal Astronomical Society*, 507 :3736, 2021.
- Zhao, Yue; Heinke, Craig O.; Shishkovsky, Laura; Strader, Jay; Chomiuk, Laura; Maccarone, Thomas J.; Bahramian, Arash; Sivakoff, Gregory R.; Miller-Jones, James C. A.; Tremou, Evangelia "The MAVERIC Survey: Dynamical Origin of Radio Sources in Galactic Globular Clusters" *The Astrophysical Journal*, 914 :77, 2021.
- Zhou, Huan; Xu, De-Zhen; Yan, Jian-Guo; Chen, Shao-Wu; Li, Hai-Tao "A new method for resolving phase ambiguity in radio interferometry using Earth rotation synthesis" *Research in Astronomy and Astrophysics*, 21 :167, 2021.

- Zhou, Jian-Wen; Liu, Tie; Li, Jin-Zeng; Liu, Hong-Li; Wang, Ke; Xu, Feng-Wei; Kim, Kee-Tae; Lee, Chang Won; Dewangan, Lokesh; Tatematsu, Ken'Ichi; Li, Shanghuo; Liu, Xun-Chuan; Tang, Mengyao; Ren, Zhiyuan; Zhang, Guo-Yin; Zhang, Chao; Liu, Rong; Luo, Qiu-Yi; Ristorcelli, Isabelle "ATOMS: ALMA Three-millimeter Observations of Massive Star-forming regions-VI. On the formation of the 'L' type filament in G286.21+0.17" Monthly Notices of the Royal Astronomical Society, 508 :4639, 2021.
- Zinchenko, I. I.; Dewangan, L. K.; Baug, T.; Ojha, D. K.; Bhadari, N. K. "ALMA discovery of a dual dense probably rotating outflow from a massive young stellar object G18.88MME" Monthly Notices of the Royal Astronomical Society, 506 :L45, 2021.
- Zurlo, Alice; Cieza, Lucas A.; Ansdell, Megan; Christiaens, Valentin; Pérez, Sebastián; Lovell, Josh; Mesa, Dino; Williams, Jonathan P.; Gonzalez-Ruilova, Camilo; Carraro, Rosamaria; Ruiz-Rodríguez, Dary; Wyatt, Mark "The effect of stellar multiplicity on protoplanetary discs: a near-infrared survey of the Lupus star-forming region" Monthly Notices of the Royal Astronomical Society, 501 :2305, 2021.

## 2022 NRAO REFEREED PUBLICATIONS

- Abbasi, R.; Ackermann, M.; Adams, J.; Aguilar, J. A.; Ahlers, M.; Ahrens, M.; Alameddine, J. M.; Alispach, C.; Alves, A. A.; Amin, N. M.; Andeen, K.; Anderson, T.; Anton, G.; Argüelles, C.; Ashida, Y.; Axani, S.; Bai, X.; Balagopal V., A.; Barbano, A.; Barwick, S. W.; Bastian, B.; Basu, V.; Baur, S.; Bay, R.; Beatty, J. J.; Becker, K.-H.; Becker Tjus, J.; Bellenghi, C.; Benzi, S.; Berley, D.; Bernardini, E.; Besson, D. Z.; Binder, G.; Bindig, D.; Blauffuss, E.; Blot, S.; Boddenberg, M.; Bontempo, F.; Borowka, J.; Böser, S.; Botner, O.; Böttcher, J.; Bourbeau, E.; Bradascio, F.; Braun, J.; Brinson, B.; Bron, S.; Brostean-Kaiser, J.; Browne, S.; Burgman, A.; Burley, R. T.; Busse, R. S.; Campana, M. A.; Carnie-Bronca, E. G.; Chen, C.; Chen, Z.; Chirkin, D.; Choi, K.; Clark, B. A.; Clark, K.; Classen, L.; Coleman, A.; Collin, G. H.; Conrad, J. M.; Coppin, P.; Correa, P.; Cowen, D. F.; Cross, R.; Dappen, C.; Dave, P.; De Clercq, C.; Delaunay, J. J.; Delgado López, D.; Dembinski, H.; Deoskar, K.; Desai, A.; Desiati, P.; De Vries, K. D.; De Wasseige, G.; De With, M.; Deyoung, T.; Diaz, A.; Díaz-Vélez, J. C.; Dittmer, M.; Dujmovic, H.; Dunkman, M.; Duvernois, M. A.; Dvorak, E.; Ehrhardt, T.; Eller, P.; Engel, R.; Erpenbeck, H.; Evans, J.; Evenson, P. A.; Fan, K. L.; Fazely, A. R.; Fedynitch, A.; Feigl, N.; Fiedlschuster, S.; Fienberg, A. T.; Filimonov, K.; Finley, C.; Fischer, L.; Fox, D.; Frankowiak, A.; Friedman, E.; Fritz, A.; Fürst, P.; Gaisser, T. K.; Gallagher, J.; Ganster, E.; Garcia, A.; Garrappa, S.; Gerhardt, L.; Ghadimi, A.; Glaser, C.; Glauch, T.; Glüsenkamp, T.; Gonzalez, J. G.; Goswami, S.; Grant, D.; Grégoire, T.; Griswold, S.; Günther, C.; Gutjahr, P.; Haack, C.; Hallgren, A.; Halliday, R.; Halve, L.; Halzen, F.; Ha Minh, M.; Hanson, K.; Hardin, J.; Harnisch, A. A.; Haungs, A.; Hebecker, D.; Helbing, K.; Henningsen, F.; Hettlinger, E. C.; Hickford, S.; Hignight, J.; Hill, C.; Hill, G. C.; Hoffman, K. D.; Hoffmann, R.; Hokanson-Fasig, B.; Hoshina, K.; Huang, F.; Huber, M.; Huber, T.; Hultqvist, K.; Hünnefeld, M.; Hussain, R.; Hyman, K.; In, S.; Iovine, N.; Ishihara, A.; Jansson, M.; Japaridze, G. S.; Jeong, M.; Jin, M.; Jones, B. J. P.; Kang, D.; Kang, W.; Kang, X.; Kappes, A.; Kappesser, D.; Kardum, L.; Karg, T.; Karl, M.; Karle, A.; Katz, U.; Kauer, M.; Kellermann, M.; Kelley, J. L.; Kheirandish, A.; Kin, K.; Kintscher, T.; Kiryluk, J.; Klein, S. R.; Koirala, R.; Kolanoski, H.; Kontrimas, T.; Köpke, L.; Kopper, C.; Kopper, S.; Koskinen, D. J.; Koundal, P.; Kovacevich, M.; Kowalski, M.; Kozynets, T.; Kun, E.; Kurahashi, N.; Lad, N.; Lagunas Gualda, C.; Lanfranchi, J. L.; Larson, M. J.; Lauber, F.; Lazar, J. P.; Lee, J. W.; Leonard, K.; Leszczyńska, A.; Li, Y.; Lincetto, M.; Liu, Q. R.; Liubarska, M.; Lohfink, E.; Lozano Mariscal, C. J.; Lu, L.; Lucarelli, F.; Ludwig, A.; Luszczak, W.; Lyu, Y.; Ma, W. Y.; Madsen, J.; Mahn, K. B. M.; Makino, Y.; Mancina, S.; Mariş, I. C.; Martinez-Soler, I.; Maruyama, R.; Mase, K.; Mcelroy, T.; McNally, F.; Mead, J. V.; Meagher, K.; Mechbal, S.; Medina, A.; Meier, M.; Meighen-Berger, S.; Micallef, J.; Mockler, D.; Montaruli, T.; Moore, R. W.; Morse, R.; Moulai, M.; Naab, R.; Nagai, R.; Naumann, U.; Necker, J.; Nguyên, L. V.; Niederhausen, H.; Nisa, M. U.; Nowicki, S. C.; Obertacke Pollmann, A.; Oehler, M.; Oeyen, B.; Olivas, A.; O'Sullivan, E.; Pandya, H.; Pankova, D. V.; Park, N.; Parker, G. K.; Paudel, E. N.; Paul, L.; Pérez De Los Heros, C.; Peters, L.; Peterson, J.; Philippen, S.; Pieper, S.; Pittermann, M.; Pizzuto, A.; Plum, M.; Popovych, Y.; Porcelli, A.; Prado Rodriguez, M.; Price, P. B.; Pries, B.; Przybylski, G. T.; Raab, C.; Raissi, A.; Rameez, M.; Rawlins, K.; Rea, I. C.; Rehman, A.; Reichherzer, P.; Reimann, R.; Renzi, G.; Resconi, E.; Reusch, S.; Rhode, W.; Richman, M.; Riedel, B.; Roberts, E. J.; Robertson, S.; Roellinghoff, G.; Rongen, M.; Rott, C.; Ruhe, T.; Ryckbosch, D.; Rysewyk Cantu, D.; Safa, I.; Saffer, J.; Sanchez Herrera, S. E.; Sandrock, A.; Sandroos, J.; Santander, M.; Sarkar, S.; Sarkar, S.; Satalecka, K.; Schaufel, M.; Schieler, H.; Schindler, S.; Schmidt, T.; Schneider, A.; Schneider, J.; Schröder, F. G.; Schumacher, L.; Schwefer, G.; Sclafani, S.; Seckel, D.; Seunarine, S.; Sharma, A.; Shefali, S.; Silva, M.; Skrzypek, B.; Smithers, B.; Snihur, R.; Soedingrekso, J.; Soldin, D.; Spannfellner, C.; Spiczak, G. M.; Spiering, C.; Stachurska, J.; Stamatikos, M.; Stanev, T.; Stein, R.; Stettner, J.; Steuer, A.; Stezelberger, T.; Stürwald, T.; Stüttard, T.; Sullivan, G. W.; Taboada, I.; Ter-Antonyan, S.; Tilav, S.; Tischbein, F.; Tollefson, K.; Tönnis, C.; Toscano, S.; Tosi, D.; Trettin, A.; Tselengidou, M.; Tung, C. F.; Turcati, A.; Turcotte, R.; Turley, C. F.; Twagirayezu, J. P.; Ty, B.; Unland Elorrieta, M. A.; Valtonen-Mattila, N.; Vandenbroucke, J.; Van Eijndhoven, N.; Vannerom, D.; Van Santen, J.; Verpoest, S.; Walck, C.; Watson, T. B.; Weaver, C.; Weigel, P.; Weindl, A.; Weiss, M. J.; Weldert, J.; Wendt, C.; Werthebach, J.; Weyrauch, M.; Whitehorn, N.; Wiebusch, C. H.; Williams, D. R.; Wolf, M.; Woschnagg, K.; Wrede, G.; Wulff, J.; Xu, X. W.; Yanez, J. P.; Yoshida, S.; Yu, S.; Yuan, T.; Zhang, Z.; Zhelmin, P.; Icecube Collaboration "Search for neutrino emission from cores of active galactic nuclei." *Physical Review D*, 106: 022005, 2022.
- Abbate, F.; Ridolfi, A.; Barr, E. D.; Buchner, S.; Burgay, M.; Champion, D. J.; Chen, W.; Freire, P. C. C.; Gautam, T.; Grießmeier, J. M.; Künkel, L.; Kramer, M.; Padmanabh, P. V.; Possenti, A.; Ransom, S.; Serylak, M.; Stappers, B. W.; Krishnan, V. Venkatraman; Behrend, J.; Breton, R. P.; Levin, L.; Men, Y. "Four pulsar discoveries in NGC 6624 by TRAPUM using MeerKAT." *Monthly Notices of the Royal Astronomical Society*, 513: 2292, 2022.
- Abdurashidova, Zara; Aguirre, James E.; Alexander, Paul; Ali, Zaki S.; Balfour, Yanga; Barkana, Renman; Beardsley, Adam P.; Bernardi, Gianni; Billings, Tashalee S.; Bowman, Judd D.; Bradley, Richard F.; Bull, Philip; Burba, Jacob; Carey, Steve; Carilli, Chris L.; Cheng, Carina; Deboer, David R.; Dexter, Matt; De Lera Acedo, Eloy; Dillon, Joshua S.; Ely, John; Ewall-Wice, Aaron; Fagnoni, Nicolas; Fialkov, Anastasia; Fritz, Randall; Furlanetto, Steven R.; Gale-Sides, Kingsley; Glendenning, Brian; Gorthi, Deepthi; Greig, Bradley; Grobbelaar, Jasper; Halday, Ziyaad; Hazelton, Bryna J.; Heimersheim, Stefan; Hewitt, Jacqueline N.; Hickish, Jack; Jacobs, Daniel C.; Julius, Austin; Kern, Nicholas S.; Kerrigan, Joshua; Kittiwisit, Piyanat; Kohn, Saul A.; Kolopanis, Matthew; Lanman, Adam; La Plante, Paul; Lekalake, Telalo; Lewis, David; Liu, Adrian; Ma, Yin-Zhe; Macmahon, David; Malan, Lourence; Malgas, Cresshim; Maree, Matthys; Martinot, Zachary E.; Matsetela, Eunice; Mesinger, Andrei; Mirocha, Jordan; Molewa, Mathakane; Morales, Miguel F.; Mosiane, Tshegofalang; Muñoz, Julian B.; Murray, Steven G.; Neben, Abraham R.; Nikolic, Bojan; Nunhokee, Chuneeta D.; Parsons, Aaron R.; Patra, Nipanjana; Pieterse, Samantha; Pober, Jonathan C.; Qin, Yuxiang; Razavi-Ghods, Nima; Reis, Itamar; Ringuette, Jon; Robnett, James; Rosie, Kathryn; Santos, Mario G.; Sikder, Sudipta; Sims, Peter; Smith, Craig; Syce, Angelo; Thyagarajan, Nithyanandan; Williams, Peter K. G.; Zheng, Haoxuan "HERA Phase I Limits on the Cosmic 21 cm Signal: Constraints on Astrophysics and Cosmology during the Epoch of Reionization." *The Astrophysical Journal*, 924: 51, 2022.
- Abdurashidova, Zara; Aguirre, James E.; Alexander, Paul; Ali, Zaki S.; Balfour, Yanga; Beardsley, Adam P.; Bernardi, Gianni; Billings, Tashalee S.; Bowman, Judd D.; Bradley, Richard F.; Bull, Philip; Burba, Jacob; Carey, Steve; Carilli, Chris L.; Cheng, Carina; Deboer, David R.; Dexter, Matt; De Lera Acedo, Eloy; Dibblee-Barkman, Taylor; Dillon, Joshua S.; Ely, John; Ewall-Wice, Aaron; Fagnoni, Nicolas; Fritz, Randall; Furlanetto, Steven R.; Gale-Sides, Kingsley; Glendenning, Brian; Gorthi, Deepthi; Greig, Bradley; Grobbelaar, Jasper; Halday, Ziyaad; Hazelton, Bryna J.; Hewitt, Jacqueline N.; Hickish, Jack; Jacobs, Daniel C.; Julius, Austin; Kern, Nicholas S.; Kerrigan, Joshua; Kittiwisit, Piyanat; Kohn, Saul A.; Kolopanis, Matthew; Lanman, Adam; La Plante, Paul; Lekalake, Telalo; Lewis, David; Liu, Adrian; Macmahon, David; Malan, Lourence; Malgas, Cresshim; Maree, Matthys; Martinot, Zachary E.; Matsetela, Eunice; Mesinger, Andrei; Molewa, Mathakane; Morales, Miguel F.; Mosiane, Tshegofalang; Murray, Steven G.; Neben, Abraham R.; Nikolic, Bojan; Nunhokee, Chuneeta D.; Parsons, Aaron R.; Patra, Nipanjana; Pascua, Robert; Pieterse, Samantha; Pober, Jonathan C.; Razavi-Ghods, Nima; Ringuette, Jon; Robnett, James; Rosie, Kathryn; Sims, Peter; Singh,



- Saurabh; Smith, Craig; Syce, Angelo; Thyagarajan, Nithyanandan; Williams, Peter K. G.; Zheng, Haoxuan; Hera Collaboration "First Results from HERA Phase I: Upper Limits on the Epoch of Reionization 21 cm Power Spectrum," *The Astrophysical Journal*, 925: 221, 2022.
- Abdurro'Uf; Accetta, Katherine; Aerts, Conny; Silva Aguirre, Víctor; Ahumada, Romina; Aijaonkar, Nikhil; Filiz Ak, N.; Alam, Shadab; Allende Prieto, Carlos; Almeida, Andrés; Anders, Friedrich; Anderson, Scott F.; Andrews, Brett H.; Anguiano, Borja; Aquino-Ortiz, Erik; Aragón-Salamanca, Alfonso; Argudo-Fernández, Maria; Ata, Metin; Aubert, Marie; Avila-Reese, Vladimir; Badenes, Carles; Barbá, Rodolfo H.; Barger, Kat; Barrera-Ballesteros, Jorge K.; Beaton, Rachael L.; Beers, Timothy C.; Belfiore, Francesco; Bender, Chad F.; Bernardi, Mariangela; Bershady, Matthew A.; Beutler, Florian; Bidin, Christian Moni; Bird, Jonathan C.; Bizyaev, Dmitry; Blanc, Guillermo A.; Blanton, Michael R.; Boardman, Nicholas Fraser; Bolton, Adam S.; Boquien, Médéric; Borissova, Jura; Bovy, Jo; Brandt, W. N.; Brown, Jordan; Brownstein, Joel R.; Brusa, Marcella; Buchner, Johannes; Bundy, Kevin; Burchett, Joseph N.; Bureau, Martin; Burgasser, Adam; Cabang, Tuesday K.; Campbell, Stephanie; Cappellari, Michele; Carlberg, Joleen K.; Wanderley, Fábio Carneiro; Carrera, Ricardo; Cash, Jennifer; Chen, Yan-Ping; Chen, Wei-Huai; Cherinka, Brian; Chiappini, Cristina; Choi, Peter Doohyun; Chojnowski, S. Drew; Chung, Haeun; Clerc, Nicolas; Cohen, Roger E.; Comerford, Julia M.; Comparat, Johan; Da Costa, Luiz; Covey, Kevin; Crane, Jeffrey D.; Cruz-Gonzalez, Irene; Culhane, Connor; Cunha, Katia; Dai, Y. Sophia; Damke, Guillermo; Darling, Jeremy; Davidson, James W., Jr.; Davies, Roger; Dawson, Kyle; De Lee, Nathan; Diamond-Stanic, Aleksandar M.; Cano-Díaz, Mariana; Sánchez, Helena Domínguez; Donor, John; Duckworth, Chris; Dwelly, Tom; Eisenstein, Daniel J.; Elsworth, Yvonne P.; Emsellem, Eric; Eracleous, Mike; Escoffier, Stephanie; Fan, Xiaohui; Farr, Emily; Feng, Shuai; Fernández-Trincado, José G.; Feuillet, Diane; Filipp, Andreas; Fillingham, Sean P.; Frinchaboy, Peter M.; Fromenteau, Sebastian; Galbany, Lluís; García, Rafael A.; García-Hernández, D. A.; Ge, Junqiang; Geisler, Doug; Gelfand, Joseph; Géron, Tobias; Gibson, Benjamin J.; Goddy, Julian; Godoy-Rivera, Diego; Grabowski, Kathleen; Green, Paul J.; Greener, Michael; Grier, Catherine J.; Griffith, Emily; Guo, Hong; Guy, Julien; Hadjara, Massinissa; Harding, Paul; Hasselquist, Sten; Hayes, Christian R.; Hearty, Fred; Hernández, Jesús; Hill, Lewis; Hogg, David W.; Holtzman, Jon A.; Horta, Danny; Hsieh, Bau-Ching; Hsu, Chin-Hao; Hsu, Yun-Hsin; Huber, Daniel; Huertas-Company, Marc; Hutchinson, Brian; Hwang, Ho Seong; Ibarra-Medel, Héctor J.; Chitham, Jacob Ider; Ilha, Gabriele S.; Imig, Julie; Jaekle, Will; Jayasinghe, Tharindu; Ji, Xihan; Johnson, Jennifer A.; Jones, Amy; Jönsson, Henrik; Katkov, Ivan; Khalatyan, Arman, Dr.; Kinemuchi, Karen; Kisku, Shobhit; Knapen, Johan H.; Kneib, Jean-Paul; Kollmeier, Juna A.; Kong, Miranda; Kounkel, Marina; Kreckel, Kathryn; Krishnarao, Dhanesh; Lacerna, Ivan; Lane, Richard R.; Langgins, Rachel; Lavender, Ramon; Law, David R.; Lazarz, Daniel; Leung, Henry W.; Leung, Ho-Hin; Lewis, Hannah M.; Li, Cheng; Li, Ran; Lian, Jianhui; Liang, Fu-Heng; Lin, Lihwai; Lin, Yen-Ting; Lin, Sicheng; Lintott, Chris; Long, Dan; Longa-Peña, Penélope; López-Cobá, Carlos; Lu, Shengdong; Lundgren, Britt F.; Luo, Yuanze; Mackereth, J. Ted; De La Macorra, Axel; Mahadevan, Suvrath; Majewski, Steven R.; Machado, Arturo; Mandeville, Travis; Maraston, Claudia; Margalef-Bentabol, Berta; Masseron, Thomas; Masters, Karen L.; Mathur, Savita; Mcdermid, Richard M.; Mckay, Myles; Merloni, Andrea; Merrifield, Michael; Meszaros, Szabolcs; Miglio, Andrea; Di Mille, Francesco; Minniti, Dante; Minsley, Rebecca; Monachesi, Antonela; Moon, Jeongin; Mosser, Benoit; Mulchaey, John; Muna, Demitri; Muñoz, Ricardo R.; Myers, Adam D.; Myers, Natalie; Nadathur, Seshadri; Nair, Preethi; Nandra, Kirpal; Neumann, Justus; Newman, Jeffrey A.; Nidever, David L.; Nikakhtar, Farnik; Nitschelm, Christian; O'Connell, Julia E.; Garma-Oehmichen, Luis; Luan Souza De Oliveira, Gabriel; Olney, Richard; Oravetz, Daniel; Ortigoza-Urdaneta, Mario; Osorio, Yeisson; Otter, Justin; Pace, Zachary J.; Padilla, Nelson; Pan, Kaike; Pan, Hsi-An; Parikh, Taniya; Parker, James; Peirani, Sebastien; Peña Ramírez, Karla; Penny, Samantha; Percival, Will J.; Perez-Fournon, Ismael; Pinsonneault, Marc; Poidevin, Frédéric; Poovelil, Vijith Jacob; Price-Whelan, Adrian M.; Bárbara De Andrade Queiroz, Anna; Raddick, M. Jordan; Ray, Amy; Rembold, Sandro Barboza; Riddle, Nicole; Riffel, Rogemar A.; Riffel, Rogério; Rix, Hans-Walter; Robin, Annie C.; Rodríguez-Puebla, Aldo; Roman-Lopes, Alexandre; Román-Zúñiga, Carlos; Rose, Benjamin; Ross, Ashley J.; Rossi, Graziano; Rubin, Kate H. R.; Salvato, Mara; Sánchez, Sebastián F.; Sánchez-Gallego, José R.; Sanderson, Robyn; Santana Rojas, Felipe Antonio; Sarceno, Edgar; Sarmiento, Regina; Sayres, Conor; Sazonova, Elizaveta; Schaefer, Adam L.; Schiavon, Ricardo; Schlegel, David J.; Schneider, Donald P.; Schultheis, Mathias; Schwöpe, Axel; Serenelli, Aldo; Serna, Javier; Shao, Zhengyi; Shapiro, Griffin; Sharma, Anubhav; Shen, Yue; Shetrone, Matthew; Shu, Yiping; Simon, Joshua D.; Skrutskie, M. F.; Smethurst, Rebecca; Smith, Verne; Soback, Jennifer; Spoo, Taylor; Sprague, Dani; Stark, David V.; Stassun, Keivan G.; Steinmetz, Matthias; Stello, Dennis; Stone-Martinez, Alexander; Storch-Bergmann, Thais; Stringfellow, Guy S.; Stutz, Amelia; Su, Yung-Chau; Taghizadeh-Popp, Manuchehr; Talbot, Michael S.; Tayar, Jamie; Telles, Eduardo; Teske, Johanna; Thakar, Ani; Theissen, Christopher; Tkachenko, Andrew; Thomas, Daniel; Tojeiro, Rita; Hernandez Toledo, Hector; Troup, Nicholas W.; Trump, Jonathan R.; Trussler, James; Turner, Jacqueline; Tuttle, Sarah; Unda-Sanzana, Eduardo; Vázquez-Mata, José Antonio; Valentini, Marica; Valenzuela, Octavio; Vargas-González, Jaime; Vargas-Magaña, Mariana; Alfaro, Pablo Vera; Villanova, Sandro; Vincenzo, Fiorenzo; Wake, David; Warfield, Jack T.; Washington, Jessica Diane; Weaver, Benjamin Alan; Weijmans, Anne-Marie; Weinberg, David H.; Weiss, Achim; Westfall, Kyle B.; Wild, Vivienne; Wilde, Matthew C.; Wilson, John C.; Wilson, Robert F.; Wilson, Mikayla; Wolf, Julien; Wood-Vasey, W. M.; Yan, Renbin; Zamora, Olga; Zasowski, Gail; Zhang, Kai; Zhao, Cheng; Zheng, Zheng; Zheng, Zheng; Zhu, Kai "The Seventeenth Data Release of the Sloan Digital Sky Surveys: Complete Release of MaNGA, MaStar, and APOGEE-2 Data," *The Astrophysical Journal Supplement Series*, 259: 35, 2022.
- Abdurro'Uf; Lin, Yen-Ting; Hirashita, Hiroyuki; Morishita, Takahiro; Tacchella, Sandro; Akiyama, Masayuki; Takeuchi, Tsutomu T.; Wu, Po-Feng "Dissecting Nearby Galaxies with piXedfit. I. Spatially Resolved Properties of Stars, Dust, and Gas as Revealed by Panchromatic SED Fitting," *The Astrophysical Journal*, 926: 81, 2022.
- Abe, Masashi; Shimizu, Toshifumi; Shimojo, Masumi "An ALMA Observation of Time Variations in Chromospheric Temperature of a Solar Plage Region," *Frontiers in Astronomy and Space Sciences*, 9: 908249, 2022.
- Abraham, Zulema; Beaklini, Pedro P. B.; Cox, Pierre; Falceta-Gonçalves, Diego; Nyman, Lars-Åke "Telluric absorption lines in the ALMA spectra of  $\eta$  Car," *Monthly Notices of the Royal Astronomical Society*, 517: 47, 2022.
- Aguirre, James E.; Murray, Steven G.; Pascua, Robert; Martinot, Zachary E.; Burba, Jacob; Dillon, Joshua S.; Jacobs, Daniel C.; Kern, Nicholas S.; Kittiwisit, Piyanat; Kolopanis, Matthew; Lanman, Adam; Liu, Adrian; Whittler, Lily; Abdurashidova, Zara; Alexander, Paul; Ali, Zaki S.; Balfour, Yanga; Beardsley, Adam P.; Bernardi, Gianni; Billings, Tashalee S.; Bowman, Judd D.; Bradley, Richard F.; Bull, Philip; Carey, Steve; Carilli, Chris L.; Cheng, Carina; Deboer, David R.; Dexter, Matt; De Lera Acedo, Eloy; Ely, John; Ewall-Wice, Aaron; Fagnoni, Nicolas; Fritz, Randall; Furlanetto, Steven R.; Gale-Sides, Kingsley; Glendenning, Brian; Gorthi, Deepthi; Greig, Bradley; Grobbelaar, Jasper; Haldaj, Ziyaad; Hazelton, Bryna J.; Hewitt, Jacqueline N.; Hickish, Jack; Julius, Austin; Kerrigan, Joshua; Kohn, Saul A.; La Plante, Paul; Lekalake, Telalo; Lewis, David; Macmahon, David; Malan, Lourencia; Malgas, Cresshim; Maree, Mathys; Matssetela, Eunice; Mesinger, Andrei; Molewa, Mathakane; Morales, Miguel F.; Mosiane, Tshagofalang; Neben, Abraham R.; Nikolic, Bojan; Parsons, Aaron R.; Patra, Nipanjana; Pieterse, Samantha; Pober, Jonathan C.; Razavi-Ghods, Nima; Ringuette, Jon; Robnett, James; Rosie, Kathryn; Santos, Mario G.; Sims, Peter; Singh, Saurabh; Smith, Craig; Syce, Angelo; Thyagarajan, Nithyanandan; Williams, Peter K. G.;

## APPENDIX A: PUBLICATIONS

- Zheng, Haoxuan; Hera Collaboration "Validation of the HERA Phase I Epoch of Reionization 21 cm Power Spectrum Software Pipeline," *The Astrophysical Journal*, 924: 85, 2022.
- Akins, Hollis B.; Fujimoto, Seiji; Finlator, Kristian; Watson, Darach; Knudsen, Kirsten K.; Richard, Johan; Bakx, Tom J. L. C.; Hashimoto, Takuya; Inoue, Akio K.; Matsuo, Hiroshi; Michałowski, Michał J.; Tamura, Yoichi "ALMA Reveals Extended Cool Gas and Hot Ionized Outflows in a Typical Star-forming Galaxy at  $z = 7.13$ ," *The Astrophysical Journal*, 934: 64, 2022.
- Akiyama, Kazunori; Alberdi, Anxón; Alef, Walter; Algaba, Juan Carlos; Anantua, Richard; Asada, Keiichi; Azulay, Rebecca; Bach, Uwe; Baczko, Anne-Kathrin; Ball, David; Baloković, Mislav; Barrett, John; Bauböck, Michi; Benson, Bradford A.; Bintley, Dan; Blackburn, Lindy; Blundell, Raymond; Bouman, Katherine L.; Bower, Geoffrey C.; Boyce, Hope; Bremer, Michael; Brinkerink, Christiaan D.; Brissenden, Roger; Britzen, Silke; Broderick, Avery E.; Brogiere, Dominique; Bronzwaer, Thomas; Bustamante, Sandra; Byun, Do-Young; Carlstrom, John E.; Ceccobello, Chiara; Chael, Andrew; Chan, Chi-Kwan; Chatterjee, Koushik; Chatterjee, Shami; Chen, Ming-Tang; Chen, Yongjun; Cheng, Xiaopeng; Cho, Ilje; Christian, Pierre; Conroy, Nicholas S.; Conway, John E.; Cordes, James M.; Crawford, Thomas M.; Crew, Geoffrey B.; Cruz-Osorio, Alejandro; Cui, Yuzhu; Davelaar, Jordy; Laurentis, Mariafelicia De; Deane, Roger; Dempsey, Jessica; Desvignes, Gregory; Dexter, Jason; Dhruv, Vedant; Doeleman, Sheperd S.; Dougal, Sean; Dzib, Sergio A.; Eatough, Ralph P.; Emami, Razieh; Falcke, Heino; Farah, Joseph; Fish, Vincent L.; Fomalont, Ed; Ford, H. Alyson; Fraga-Encinas, Raquel; Freeman, William T.; Friberg, Per; Fromm, Christian M.; Fuentes, Antonio; Galison, Peter; Gammie, Charles F.; García, Roberto; Gentaz, Olivier; Georgiev, Boris; Goddi, Ciriaco; Gold, Roman; Gómez-Ruiz, Arturo I.; Gómez, José L.; Gu, Minfeng; Gurwell, Mark; Hada, Kazuhiro; Haggard, Daryl; Haworth, Kari; Hecht, Michael H.; Hesper, Ronald; Heumann, Dirk; Ho, Luis C.; Ho, Paul; Honma, Mareki; Huang, Chih-Wei L.; Huang, Lei; Hughes, David H.; Ikeda, Shiro; Impellizzeri, C. M. Violette; Inoue, Makoto; Issaoun, Sara; James, David J.; Jannuzi, Buell T.; Janssen, Michael; Jeter, Britton; Jiang, Wu; Jiménez-Rosales, Alejandra; Johnson, Michael D.; Jorstad, Svetlana; Joshi, Abhishek V.; Jung, Taehyun; Karami, Mansour; Karuppusamy, Ramesh; Kawashima, Tomohisa; Keating, Garrett K.; Kettenis, Mark; Kim, Dong-Jin; Kim, Jae-Young; Kim, Jongsoo; Kim, Junhan; Kino, Motoki; Koay, Jun Yi; Kocherlakota, Prashant; Kofuji, Yutaro; Koch, Patrick M.; Koyama, Shoko; Kramer, Carsten; Kramer, Michael; Krichbaum, Thomas P.; Kuo, Cheng-Yu; Bella, Noemi La; Lauer, Tod R.; Lee, Daeyoung; Lee, Sang-Sung; Leung, Po Kin; Levis, Aviad; Li, Zhiyuan; Lico, Rocco; Lindahl, Greg; Lindqvist, Michael; Lisakov, Mikhail; Liu, Jun; Liu, Kuo; Liuzzo, Elisabetta; Lo, Wen-Ping; Lobanov, Andrei P.; Loinard, Laurent; Lonsdale, Colin J.; Lu, Ru-Sen; Mao, Jirong; Marchili, Nicola; Markoff, Sera; Marrone, Daniel P.; Marscher, Alan P.; Martí-Vidal, Iván; Matsushita, Satoki; Matthews, Lynn D.; Medeiros, Lia; Menten, Karl M.; Michalik, Daniel; Mizuno, Izumi; Mizuno, Yosuke; Moran, James M.; Moriyama, Kotaro; Moscibrodzka, Monika; Müller, Cornelia; Mus, Alejandro; Musoke, Gibwa; Myserlis, Ioannis; Nadolski, Andrew; Nagai, Hiroshi; Nagar, Neil M.; Nakamura, Masanori; Narayan, Ramesh; Narayanan, Gopal; Natarajan, Iniyán; Nathanail, Antonios; Fuentes, Santiago Navarro; Nielsen, Joey; Neri, Roberto; Ni, Chunhong; Noutsos, Aristeidis; Nowak, Michael A.; Oh, Junghwan; Okino, Hiroki; Olivares, Héctor; Ortiz-León, Gisela N.; Oyama, Tomoaki; Özel, Feryal; Palumbo, Daniel C. M.; Paraschos, Georgios Filippou; Park, Jongho; Parsons, Harriet; Patel, Nimesh; Pen, Ue-Li; Pesce, Dominic W.; Piétu, Vincent; Plambeck, Richard; Popstefanija, Aleksandar; Porth, Oliver; Pözl, Felix M.; Prather, Ben; Preciado-López, Jorge A.; Psaltis, Dimitrios; Pu, Hung-Yi; Ramakrishnan, Venkatesh; Rao, Ramprasad; Rawlings, Mark G.; Raymond, Alexander W.; Rezzolla, Luciano; Ricarte, Angelo; Ripperda, Bart; Roelofs, Freek; Rogers, Alan; Ros, Eduardo; Romero-Cañizales, Cristina; Roshanineshat, Arash; Rottmann, Helge; Roy, Alan L.; Ruiz, Ignacio; Ruszczyk, Chet; Rygl, Kazi L. J.; Sánchez, Salvador; Sánchez-Argüelles, David; Sánchez-Portal, Miguel; Sasada, Mahito; Satapathy, Kaushik; Savolainen, Tuomas; Schloerb, F. Peter; Schonfeld, Jonathan; Schuster, Karl-Friedrich; Shao, Lijing; Shen, Zhiqiang; Small, Des; Sohn, Bong Won; Soohoo, Jason; Souccar, Kamal; Sun, He; Tazaki, Fumie; Tetarenko, Alexandra J.; Tiede, Paul; Tilanus, Remo P. J.; Titus, Michael; Torne, Pablo; Traianou, Efthalia; Trent, Tyler; Trippé, Sascha; Turk, Matthew; Van Bemmel, Ilse; Van Langevelde, Huib Jan; Van Rossum, Daniel R.; Vos, Jesse; Wagner, Jan; Ward-Thompson, Derek; Wardle, John; Weintraub, Jonathan; Wex, Norbert; Wharton, Robert; Wielgus, Maciek; Wiik, Kaj; Witzel, Gunther; Wondrak, Michael F.; Wong, George N.; Wu, Qingwen; Yamaguchi, Paul; Yoon, Doosoo; Young, André; Young, Ken; Younsi, Ziri; Yuan, Feng; Yuan, Ye-Fei; Zensus, J. Anton; Zhang, Shuo; Zhao, Guang-Yao; Zhao, Shan-Shan; Agurto, Claudio; Allardi, Alexander; Amestica, Rodrigo; Araneda, Juan Pablo; Arriagada, Oriol; Berghuis, Jennie L.; Bertarini, Alessandra; Berthold, Ryan; Blanchard, Jay; Brown, Ken; Cárdenas, Mauricio; Cantzler, Michael; Caro, Patricio; Castillo-Domínguez, Edgar; Chan, Tin Lok; Chang, Chih-Cheng; Chang, Dominic O.; Chang, Shu-Hao; Chang, Song-Chu; Chen, Chung-Chen; Chilson, Ryan; Chuter, Tim C.; Ciechanowicz, Mirosław; Colin-Beltran, Edgar; Coulson, Iain M.; Crowley, Joseph; Degenaar, Nathalie; Dornbusch, Sven; Durán, Carlos A.; Everett, Wendeline B.; Faber, Aaron; Forster, Karl; Fuchs, Miriam M.; Gale, David M.; Geertsema, Gertie; González, Eduardo; Graham, Dave; Gueth, Frédéric; Halverson, Nils W.; Han, Chih-Chiang; Han, Kuo-Chang; Hasegawa, Yutaka; Hernández-Rebollar, José Luis; Herrera, Cristian; Herrero-Illana, Ruben; Heyminck, Stefan; Hirota, Akihiko; Hoge, James; Hostler Schimpf, Shelbi R.; Howie, Ryan E.; Huang, Yau-De; Jiang, Homin; Jinchí, Hao; John, David; Kimura, Kimihiro; Klein, Thomas; Kubo, Derek; Kuroda, John; Kwon, Caleb; Lacasse, Richard; Laing, Robert; Leitch, Erik M.; Li, Chao-Te; Liu, Ching-Tang; Liu, Kuan-Yu; Lin, Lupin C.-C.; Lu, Li-Ming; Mac-Auliffe, Felipe; Martin-Cocher, Pierre; Matulonis, Callie; Maute, John K.; Messias, Hugo; Meyer-Zhao, Zheng; Montaña, Alfredo; Montenegro-Montes, Francisco; Montgomerie, William; Moreno Nolasco, Marcos Emir; Muders, Dirk; Nishioka, Hiroaki; Norton, Timothy J.; Nystrom, George; Ogawa, Hideo; Olivares, Rodrigo; Oshiro, Peter; Pérez-Beaupuits, Juan Pablo; Parra, Rodrigo; Phillips, Neil M.; Poirier, Michael; Pradel, Nicolas; Qiu, Richard; Raffin, Philippe A.; Rahlin, Alexandra S.; Ramírez, Jorge; Ressler, Sean; Reynolds, Mark; Rodríguez-Montoya, Iván; Saez-Madain, Alejandro F.; Santana, Jorge; Shaw, Paul; Shirkey, Leslie E.; Silva, Kevin M.; Snow, William; Sousa, Don; Sridharan, T. K.; Stahm, William; Stark, Anthony A.; Test, John; Torstensson, Karl; Venegas, Paulina; Walther, Craig; Wei, Ta-Shun; White, Chris; Wieching, Gundolf; Wijnands, Rudy; Wouterloot, Jan G. A.; Yu, Chen-Yu; Yu ( ), Wei; Zeballos, Milagros "First Sagittarius A\* Event Horizon Telescope Results. I. The Shadow of the Supermassive Black Hole in the Center of the Milky Way," *The Astrophysical Journal*, 930: L12, 2022.
- Akiyama, Kazunori; Alberdi, Anxón; Alef, Walter; Algaba, Juan Carlos; Anantua, Richard; Asada, Keiichi; Azulay, Rebecca; Bach, Uwe; Baczko, Anne-Kathrin; Ball, David; Baloković, Mislav; Barrett, John; Bauböck, Michi; Benson, Bradford A.; Bintley, Dan; Blackburn, Lindy; Blundell, Raymond; Bouman, Katherine L.; Bower, Geoffrey C.; Boyce, Hope; Bremer, Michael; Brinkerink, Christiaan D.; Brissenden, Roger; Britzen, Silke; Broderick, Avery E.; Brogiere, Dominique; Bronzwaer, Thomas; Bustamante, Sandra; Byun, Do-Young; Carlstrom, John E.; Ceccobello, Chiara; Chael, Andrew; Chan, Chi-Kwan; Chatterjee, Koushik; Chatterjee, Shami; Chen, Ming-Tang; Chen, Yongjun; Cheng, Xiaopeng; Cho, Ilje; Christian, Pierre; Conroy, Nicholas S.; Conway, John E.; Cordes, James M.; Crawford, Thomas M.; Crew, Geoffrey B.; Cruz-Osorio, Alejandro; Cui, Yuzhu; Davelaar, Jordy; De Laurentis, Mariafelicia; Deane, Roger; Dempsey, Jessica; Desvignes, Gregory; Dexter, Jason; Dhruv, Vedant; Doeleman, Sheperd S.; Dougal, Sean; Dzib, Sergio A.; Eatough, Ralph P.; Emami, Razieh; Falcke, Heino; Farah, Joseph; Fish, Vincent L.; Fomalont, Ed; Ford, H. Alyson; Fraga-Encinas, Raquel; Freeman, William T.; Friberg, Per; Fromm, Christian M.; Fuentes, Antonio; Galison, Peter; Gammie, Charles F.; García, Roberto;

Gentaz, Olivier; Georgiev, Boris; Goddi, Ciriaco; Gold, Roman; Gómez-Ruiz, Arturo I.; Gómez, José L.; Gu, Minfeng; Gurwell, Mark; Hada, Kazuhiro; Haggard, Daryl; Haworth, Kari; Hecht, Michael H.; Hesper, Ronald; Heumann, Dirk; Ho, Luis C.; Ho, Paul; Honma, Mareki; Huang, Chih-Wei L.; Huang, Lei; Hughes, David H.; Ikeda, Shiro; Impellizzeri, C. M. Violette; Inoue, Makoto; Issaoun, Sara; James, David J.; Jannuzi, Buell T.; Janssen, Michael; Jeter, Britton; Jiang, Wu; Jiménez-Rosales, Alejandra; Johnson, Michael D.; Jorstad, Svetlana; Joshi, Abhishek V.; Jung, Taehyun; Karami, Mansour; Karuppusamy, Ramesh; Kawashima, Tomohisa; Keating, Garrett K.; Kettenis, Mark; Kim, Dong-Jin; Kim, Jae-Young; Kim, Jongsoo; Kim, Junhan; Kino, Motoki; Koay, Jun Yi; Kocherlakota, Prashant; Kofuji, Yutaro; Koch, Patrick M.; Koyama, Shoko; Kramer, Carsten; Kramer, Michael; Krichbaum, Thomas P.; Kuo, Cheng-Yu; Bella, Noemi La; Lauer, Tod R.; Lee, Daeyoung; Lee, Sang-Sung; Leung, Po Kin; Levis, Aviad; Li, Zhiyuan; Lico, Rocco; Lindahl, Greg; Lindqvist, Michael; Lisakov, Mikhail; Liu, Jun; Liu, Kuo; Liuzzo, Elisabetta; Lo, Wen-Ping; Lobanov, Andrei P.; Loinard, Laurent; Lonsdale, Colin J.; Lu, Ru-Sen; Mao, Jirong; Marchili, Nicola; Markoff, Sera; Marrone, Daniel P.; Marscher, Alan P.; Martí-Vidal, Iván; Matsushita, Satoki; Matthews, Lynn D.; Medeiros, Lia; Menten, Karl M.; Michalik, Daniel; Mizuno, Izumi; Mizuno, Yosuke; Moran, James M.; Moriyama, Kotaro; Moscibrodzka, Monika; Müller, Cornelia; Mus, Alejandro; Musoke, Gibwa; Myserlis, Ioannis; Nadolski, Andrew; Nagai, Hiroshi; Nagar, Neil M.; Nakamura, Masanori; Narayan, Ramesh; Narayanan, Gopal; Natarajan, Iniyang; Nathanail, Antonios; Fuentes, Santiago Navarro; Neilsen, Joey; Neri, Roberto; Ni, Chunchong; Noutsos, Aristeidis; Nowak, Michael A.; Oh, Junghwan; Okino, Hiroki; Olivares, Héctor; Ortiz-León, Gisela N.; Oyama, Tomoaki; Özel, Feryal; Palumbo, Daniel C. M.; Paraschos, Georgios Filippou; Park, Jongho; Parsons, Harriet; Patel, Nimesh; Pen, Ue-Li; Pesce, Dominic W.; Piétu, Vincent; Plambeck, Richard; Popstefanija, Aleksandar; Porth, Oliver; Pötl, Felix M.; Prather, Ben; Preciado-López, Jorge A.; Psaltis, Dimitrios; Pu, Hung-Yi; Ramakrishnan, Venkatesh; Rao, Ramprasad; Rawlings, Mark G.; Raymond, Alexander W.; Rezzolla, Luciano; Ricarte, Angelo; Ripperda, Bart; Roelofs, Freek; Rogers, Alan; Ros, Eduardo; Romero-Cañizales, Cristina; Roshanineshat, Arash; Rottmann, Helge; Roy, Alan L.; Ruiz, Ignacio; Ruszczyk, Chet; Rygl, Kazi L. J.; Sánchez, Salvador; Sánchez-Argüelles, David; Sánchez-Portal, Miguel; Sasada, Mahito; Satapathy, Kaushik; Savolainen, Tuomas; Schloerb, F. Peter; Schonfeld, Jonathan; Schuster, Karl-Friedrich; Shao, Lijing; Shen, Zhiqiang; Small, Des; Sohn, Bong Won; Soohoo, Jason; Souccar, Kamal; Sun, He; Tazaki, Fumie; Tetarenko, Alexandra J.; Tiede, Paul; Tilanus, Remo P. J.; Titus, Michael; Torne, Pablo; Traianou, Efthalia; Trent, Tyler; Trippe, Sascha; Turk, Matthew; Van Bemmel, Ilse; Van Langevelde, Huib Jan; Van Rossum, Daniel R.; Vos, Jesse; Wagner, Jan; Ward-Thompson, Derek; Wardle, John; Weintraub, Jonathan; Wex, Norbert; Wharton, Robert; Wielgus, Maciek; Wiik, Kaj; Witzel, Gunther; Wondrak, Michael F.; Wong, George N.; Wu, Qingwen; Yamaguchi, Paul; Yoon, Doosoo; Young, André; Young, Ken; Younsi, Ziri; Yuan, Feng; Yuan, Ye-Fei; Zensus, J. Anton; Zhang, Shuo; Zhao, Guang-Yao; Zhao, Shan-Shan; Agurto, Claudio; Araneda, Juan Pablo; Arriagada, Oriol; Bertarini, Alessandra; Berthold, Ryan; Blanchard, Jay; Brown, Ken; Cárdenas, Mauricio; Cantzler, Michael; Caro, Patricia; Chuter, Tim C.; Ciechanowicz, Mirosław; Coulson, Iain M.; Crowley, Joseph; Degenaar, Nathalie; Dornbusch, Sven; Durán, Carlos A.; Forster, Karl; Geertsema, Gertie; González, Edouard; Graham, Dave; Gueth, Frédéric; Han, Chih-Chiang; Herrera, Cristian; Herrero-Illana, Ruben; Heyminck, Stefan; Hoge, James; Huang, Yau-De; Jiang, Homin; John, David; Klein, Thomas; Kubo, Derek; Kuroda, John; Kwon, Caleb; Laing, Robert; Liu, Ching-Tang; Liu, Kuan-Yu; Mac-Auliffe, Felipe; Martin-Cocher, Pierre; Matulonis, Callie; Messias, Hugo; Meyer-Zhao, Zheng; Montenegro-Montes, Francisco; Montmerie, William; Muders, Dirk; Nishioka, Hiroaki; Norton, Timothy J.; Olivares, Rodrigo; Pérez-Beaupuits, Juan Pablo; Parra, Rodrigo; Poirier, Michael; Pradel, Nicolas; Raffin, Philippe A.; Ramírez, Jorge; Reynolds, Mark; Saez-Madain, Alejandro F.; Santana,

Jorge; Silva, Kevin M.; Sousa, Don; Stahm, William; Torstensson, Karl; Venegas, Paulina; Walther, Craig; Wieching, Gundolf; Wijnands, Rudy; Wouterloot, Jan G. A. "First Sagittarius A\* Event Horizon Telescope Results. II. EHT and Multiwavelength Observations, Data Processing, and Calibration," *The Astrophysical Journal*, 930: L13, 2022.

Akiyama, Kazunori; Alberdi, Antxon; Alef, Walter; Albeda, Juan Carlos; Anantua, Richard; Asada, Keiichi; Azulay, Rebecca; Bach, Uwe; Baczkó, Anne-Kathrin; Ball, David; Baloković, Mislav; Barrett, John; Bauböck, Michi; Benson, Bradford A.; Bintley, Dan; Blackburn, Lindy; Blundell, Raymond; Bouman, Katherine L.; Bower, Geoffrey C.; Boyce, Hope; Bremer, Michael; Brinkerink, Christiaan D.; Brissenden, Roger; Britzen, Silke; Broderick, Avery E.; Brogiere, Dominique; Bronzwaer, Thomas; Bustamante, Sandra; Byun, Do-Young; Carlstrom, John E.; Ceccobello, Chiara; Chael, Andrew; Chan, Chi-Kwan; Chatterjee, Koushik; Chatterjee, Shami; Chen, Ming-Tang; Chen, Yongjun; Cheng, Xiaopeng; Cho, Ilje; Christian, Pierre; Conroy, Nicholas S.; Conway, John E.; Cordes, James M.; Crawford, Thomas M.; Crew, Geoffrey B.; Cruz-Orsorio, Alejandro; Cui, Yuzhu; Davelaar, Jordy; De Laurentis, Mariafelicia; Deane, Roger; Dempsey, Jessica; Desvignes, Gregory; Dexter, Jason; Dhruv, Vedant; Doeleman, Sheperd S.; Dougal, Sean; Dzib, Sergio A.; Eatough, Ralph P.; Emami, Razieh; Falcke, Heino; Farah, Joseph; Fish, Vincent L.; Fomalont, Ed; Ford, H. Alyson; Fraga-Encinas, Raquel; Freeman, William T.; Friberg, Per; Fromm, Christian M.; Fuentes, Antonio; Galison, Peter; Gammie, Charles F.; García, Roberto; Gentaz, Olivier; Georgiev, Boris; Goddi, Ciriaco; Gold, Roman; Gómez-Ruiz, Arturo I.; Gómez, José L.; Gu, Minfeng; Gurwell, Mark; Hada, Kazuhiro; Haggard, Daryl; Haworth, Kari; Hecht, Michael H.; Hesper, Ronald; Heumann, Dirk; Ho, Luis C.; Ho, Paul; Honma, Mareki; Huang, Chih-Wei L.; Huang, Lei; Hughes, David H.; Ikeda, Shiro; Impellizzeri, C. M. Violette; Inoue, Makoto; Issaoun, Sara; James, David J.; Jannuzi, Buell T.; Janssen, Michael; Jeter, Britton; Jiang, Wu; Jiménez-Rosales, Alejandra; Johnson, Michael D.; Jorstad, Svetlana; Joshi, Abhishek V.; Jung, Taehyun; Karami, Mansour; Karuppusamy, Ramesh; Kawashima, Tomohisa; Keating, Garrett K.; Kettenis, Mark; Kim, Dong-Jin; Kim, Jae-Young; Kim, Jongsoo; Kim, Junhan; Kino, Motoki; Koay, Jun Yi; Kocherlakota, Prashant; Kofuji, Yutaro; Koch, Patrick M.; Koyama, Shoko; Kramer, Carsten; Kramer, Michael; Krichbaum, Thomas P.; Kuo, Cheng-Yu; Bella, Noemi La; Lauer, Tod R.; Lee, Daeyoung; Lee, Sang-Sung; Leung, Po Kin; Levis, Aviad; Li, Zhiyuan; Lico, Rocco; Lindahl, Greg; Lindqvist, Michael; Lisakov, Mikhail; Liu, Jun; Liu, Kuo; Liuzzo, Elisabetta; Lo, Wen-Ping; Lobanov, Andrei P.; Loinard, Laurent; Lonsdale, Colin J.; Lu, Ru-Sen; Mao, Jirong; Marchili, Nicola; Markoff, Sera; Marrone, Daniel P.; Marscher, Alan P.; Martí-Vidal, Iván; Matsushita, Satoki; Matthews, Lynn D.; Medeiros, Lia; Menten, Karl M.; Michalik, Daniel; Mizuno, Izumi; Mizuno, Yosuke; Moran, James M.; Moriyama, Kotaro; Moscibrodzka, Monika; Müller, Cornelia; Mus, Alejandro; Musoke, Gibwa; Myserlis, Ioannis; Nadolski, Andrew; Nagai, Hiroshi; Nagar, Neil M.; Nakamura, Masanori; Narayan, Ramesh; Narayanan, Gopal; Natarajan, Iniyang; Nathanail, Antonios; Fuentes, Santiago Navarro; Neilsen, Joey; Neri, Roberto; Ni, Chunchong; Noutsos, Aristeidis; Nowak, Michael A.; Oh, Junghwan; Okino, Hiroki; Olivares, Héctor; Ortiz-León, Gisela N.; Oyama, Tomoaki; Özel, Feryal; Palumbo, Daniel C. M.; Paraschos, Georgios Filippou; Park, Jongho; Parsons, Harriet; Patel, Nimesh; Pen, Ue-Li; Pesce, Dominic W.; Piétu, Vincent; Plambeck, Richard; Popstefanija, Aleksandar; Porth, Oliver; Pötl, Felix M.; Prather, Ben; Preciado-López, Jorge A.; Psaltis, Dimitrios; Pu, Hung-Yi; Ramakrishnan, Venkatesh; Rao, Ramprasad; Rawlings, Mark G.; Raymond, Alexander W.; Rezzolla, Luciano; Ricarte, Angelo; Ripperda, Bart; Roelofs, Freek; Rogers, Alan; Ros, Eduardo; Romero-Cañizales, Cristina; Roshanineshat, Arash; Rottmann, Helge; Roy, Alan L.; Ruiz, Ignacio; Ruszczyk, Chet; Rygl, Kazi L. J.; Sánchez, Salvador; Sánchez-Argüelles, David; Sánchez-Portal, Miguel; Sasada, Mahito; Satapathy, Kaushik; Savolainen, Tuomas; Schloerb, F. Peter; Schonfeld, Jonathan; Schuster, Karl-Friedrich; Shao, Lijing; Shen, Zhiqiang; Small, Des; Sohn, Bong Won; Soohoo, Jason; Souccar, Kamal; Sun, He; Tazaki, Fumie;

## APPENDIX A: PUBLICATIONS

- Tetarenko, Alexandra J.; Tiede, Paul; Tilanus, Remo P. J.; Titus, Michael; Torne, Pablo; Traianou, Efthalia; Trent, Tyler; Trippe, Sascha; Turk, Matthew; Van Bommel, Ilse; Van Langevelde, Huib Jan; Van Rossum, Daniel R.; Vos, Jesse; Wagner, Jan; Ward-Thompson, Derek; Wardle, John; Weintraub, Jonathan; Wex, Norbert; Wharton, Robert; Wielgus, Maciek; Wiik, Kaj; Witzel, Gunther; Wondrak, Michael F.; Wong, George N.; Wu, Qingwen; Yamaguchi, Paul; Yoon, Doosoo; Young, André; Young, Ken; Younsi, Ziri; Yuan, Feng; Yuan, Ye-Fei; Zensus, J. Anton; Zhang, Shuo; Zhao, Guang-Yao; Zhao, Shan-Shan "First Sagittarius A\* Event Horizon Telescope Results. III. Imaging of the Galactic Center Supermassive Black Hole," *The Astrophysical Journal*, 930: L14, 2022.
- Akiyama, Kazunori; Alberdi, Antxon; Alef, Walter; Algaba, Juan Carlos; Anantua, Richard; Asada, Keiichi; Azulay, Rebecca; Bach, Uwe; Baczko, Anne-Kathrin; Ball, David; Baloković, Mislav; Barrett, John; Bauböck, Michi; Benson, Bradford A.; Bintley, Dan; Blackburn, Lindy; Blundell, Raymond; Bouman, Katherine L.; Bower, Geoffrey C.; Boyce, Hope; Bremer, Michael; Brinkerink, Christiaan D.; Brissenden, Roger; Britzen, Silke; Broderick, Avery E.; Brogiere, Dominique; Bronzwaer, Thomas; Bustamante, Sandra; Byun, Do-Young; Carlstrom, John E.; Ceccobello, Chiara; Chael, Andrew; Chan, Chi-Kwan; Chatterjee, Koushik; Chatterjee, Shami; Chen, Ming-Tang; Chen, Yongjun; Cheng, Xiaopeng; Cho, Ilje; Christian, Pierre; Conroy, Nicholas S.; Conway, John E.; Cordes, James M.; Crawford, Thomas M.; Crew, Geoffrey B.; Cruz-Orsorio, Alejandro; Cui, Yuzhu; Davelaar, Jordy; Laurentis, Mariafelicia De; Deane, Roger; Dempsey, Jessica; Desvignes, Gregory; Dexter, Jason; Dhruv, Vedant; Doeleman, Sheperd S.; Dougal, Sean; Dzib, Sergio A.; Eatough, Ralph P.; Emami, Razieh; Falcke, Heino; Farah, Joseph; Fish, Vincent L.; Fomalont, Ed; Ford, H. Alyson; Fraga-Encinas, Raquel; Freeman, William T.; Friberg, Per; Fromm, Christian M.; Fuentes, Antonio; Galison, Peter; Gammie, Charles F.; García, Roberto; Gentaz, Olivier; Georgiev, Boris; Goddi, Ciriaco; Gold, Roman; Gómez-Ruiz, Arturo I.; Gómez, José L.; Gu, Minfeng; Gurwell, Mark; Hada, Kazuhiro; Haggard, Daryl; Haworth, Kari; Hecht, Michael H.; Hesper, Ronald; Heumann, Dirk; Ho, Luis C.; Ho, Paul; Honma, Mareki; Huang, Chih-Wei L.; Huang, Lei; Hughes, David H.; Ikeda, Shiro; Impellizzeri, C. M. Violette; Inoue, Makoto; Issaoun, Sara; James, David J.; Jannuzi, Buell T.; Janssen, Michael; Jeter, Britton; Jiang, Wu; Jiménez-Rosales, Alejandra; Johnson, Michael D.; Jorstad, Svetlana; Joshi, Abhishek V.; Jung, Taehyun; Karami, Mansour; Karuppusamy, Ramesh; Kawashima, Tomohisa; Keating, Garrett K.; Kettenis, Mark; Kim, Dong-Jin; Kim, Jae-Young; Kim, Jongsoo; Kim, Junhan; Kino, Motoki; Koay, Jun Yi; Kocherlakota, Prashant; Kofuji, Yutaro; Koch, Patrick M.; Koyama, Shoko; Kramer, Carsten; Kramer, Michael; Krichbaum, Thomas P.; Kuo, Cheng-Yu; Bella, Noemi La; Lauer, Tod R.; Lee, Daeyoung; Lee, Sang-Sung; Leung, Po Kin; Levis, Aviad; Li, Zhiyuan; Lico, Rocco; Lindahl, Greg; Lindqvist, Michael; Lisakov, Mikhail; Liu, Jun; Liu, Kuo; Liuzzo, Elisabetta; Lo, Wen-Ping; Lobanov, Andrei P.; Loinard, Laurent; Lonsdale, Colin J.; Lu, Ru-Sen; Mao, Jirong; Marchili, Nicola; Markoff, Sera; Marrone, Daniel P.; Marscher, Alan P.; Martí-Vidal, Iván; Matsushita, Satoki; Matthews, Lynn D.; Medeiros, Lia; Menten, Karl M.; Michalik, Daniel; Mizuno, Izumi; Mizuno, Yosuke; Moran, James M.; Moriyama, Kotaro; Moscibrodzka, Monika; Müller, Cornelia; Mus, Alejandro; Musoke, Gibwa; Myserlis, Ioannis; Nadolski, Andrew; Nagai, Hiroshi; Nagar, Neil M.; Nakamura, Masanori; Narayan, Ramesh; Narayanan, Gopal; Natarajan, Iniyani; Nathanail, Antonios; Fuentes, Santiago Navarro; Neilsen, Joey; Neri, Roberto; Ni, Chunchong; Noutsos, Aristeidis; Nowak, Michael A.; Oh, Junghwan; Okino, Hiroki; Olivares, Héctor; Ortiz-León, Gisela N.; Oyama, Tomoaki; Palumbo, Daniel C. M.; Paraschos, Georgios Filippous; Park, Jongho; Parsons, Harriet; Patel, Nimesh; Pen, Ue-Li; Pesce, Dominic W.; Piétu, Vincent; Plambeck, Richard; Popstefanija, Aleksandar; Porth, Oliver; Pötzl, Felix M.; Prather, Ben; Preciado-López, Jorge A.; Pu, Hung-Yi; Ramakrishnan, Venkatesh; Rao, Ramprasad; Rawlings, Mark G.; Raymond, Alexander W.; Rezzolla, Luciano; Ricarte, Angelo; Ripperda, Bart; Roelofs, Freek; Rogers, Alan; Ros, Eduardo; Romero-Cañizales, Cristina; Roshanineshat, Arash; Rottmann, Helge; Roy, Alan L.; Ruiz, Ignacio; Ruszczyk, Chet; Rygl, Kazi L. J.; Sánchez, Salvador; Sánchez-Argüelles, David; Sánchez-Portal, Miguel; Sasada, Mahito; Satapathy, Kaushik; Savolainen, Tuomas; Schloerb, F. Peter; Schonfeld, Jonathan; Schuster, Karl-Friedrich; Shao, Lijing; Shen, Zhiqiang; Small, Des; Sohn, Bong Won; Soohoo, Jason; Souccar, Kamal; Sun, He; Tazaki, Fumie; Tetarenko, Alexandra J.; Tiede, Paul; Tilanus, Remo P. J.; Titus, Michael; Torne, Pablo; Traianou, Efthalia; Trent, Tyler; Trippe, Sascha; Turk, Matthew; Van Bommel, Ilse; Van Langevelde, Huib Jan; Van Rossum, Daniel R.; Vos, Jesse; Wagner, Jan; Ward-Thompson, Derek; Wardle, John; Weintraub, Jonathan; Wex, Norbert; Wharton, Robert; Wielgus, Maciek; Wiik, Kaj; Witzel, Gunther; Wondrak, Michael F.; Wong, George N.; Wu, Qingwen; Yamaguchi, Paul; Yoon, Doosoo; Young, André; Young, Ken; Younsi, Ziri; Yuan, Feng; Yuan, Ye-Fei; Zensus, J. Anton; Zhang, Shuo; Zhao, Guang-Yao; Zhao, Shan-Shan; Chang, Dominic O. "First Sagittarius A\* Event Horizon Telescope Results. IV. Variability, Morphology, and Black Hole Mass," *The Astrophysical Journal*, 930: L15, 2022.
- Akiyama, Kazunori; Alberdi, Antxon; Alef, Walter; Algaba, Juan Carlos; Anantua, Richard; Asada, Keiichi; Azulay, Rebecca; Bach, Uwe; Baczko, Anne-Kathrin; Ball, David; Baloković, Mislav; Barrett, John; Bauböck, Michi; Benson, Bradford A.; Bintley, Dan; Blackburn, Lindy; Blundell, Raymond; Bouman, Katherine L.; Bower, Geoffrey C.; Boyce, Hope; Bremer, Michael; Brinkerink, Christiaan D.; Brissenden, Roger; Britzen, Silke; Broderick, Avery E.; Brogiere, Dominique; Bronzwaer, Thomas; Bustamante, Sandra; Byun, Do-Young; Carlstrom, John E.; Ceccobello, Chiara; Chael, Andrew; Chan, Chi-Kwan; Chatterjee, Koushik; Chatterjee, Shami; Chen, Ming-Tang; Chen, Yongjun; Cheng, Xiaopeng; Cho, Ilje; Christian, Pierre; Conroy, Nicholas S.; Conway, John E.; Cordes, James M.; Crawford, Thomas M.; Crew, Geoffrey B.; Cruz-Orsorio, Alejandro; Cui, Yuzhu; Davelaar, Jordy; De Laurentis, Mariafelicia; Deane, Roger; Dempsey, Jessica; Desvignes, Gregory; Dexter, Jason; Dhruv, Vedant; Doeleman, Sheperd S.; Dougal, Sean; Dzib, Sergio A.; Eatough, Ralph P.; Emami, Razieh; Falcke, Heino; Farah, Joseph; Fish, Vincent L.; Fomalont, Ed; Ford, H. Alyson; Fraga-Encinas, Raquel; Freeman, William T.; Friberg, Per; Fromm, Christian M.; Fuentes, Antonio; Galison, Peter; Gammie, Charles F.; García, Roberto; Gentaz, Olivier; Georgiev, Boris; Goddi, Ciriaco; Gold, Roman; Gómez-Ruiz, Arturo I.; Gómez, José L.; Gu, Minfeng; Gurwell, Mark; Hada, Kazuhiro; Haggard, Daryl; Haworth, Kari; Hecht, Michael H.; Hesper, Ronald; Heumann, Dirk; Ho, Luis C.; Ho, Paul; Honma, Mareki; Huang, Chih-Wei L.; Huang, Lei; Hughes, David H.; Ikeda, Shiro; Impellizzeri, C. M. Violette; Inoue, Makoto; Issaoun, Sara; James, David J.; Jannuzi, Buell T.; Janssen, Michael; Jeter, Britton; Jiang, Wu; Jiménez-Rosales, Alejandra; Johnson, Michael D.; Jorstad, Svetlana; Joshi, Abhishek V.; Jung, Taehyun; Karami, Mansour; Karuppusamy, Ramesh; Kawashima, Tomohisa; Keating, Garrett K.; Kettenis, Mark; Kim, Dong-Jin; Kim, Jae-Young; Kim, Jongsoo; Kim, Junhan; Kino, Motoki; Koay, Jun Yi; Kocherlakota, Prashant; Kofuji, Yutaro; Koch, Patrick M.; Koyama, Shoko; Kramer, Carsten; Kramer, Michael; Krichbaum, Thomas P.; Kuo, Cheng-Yu; Bella, Noemi La; Lauer, Tod R.; Lee, Daeyoung; Lee, Sang-Sung; Leung, Po Kin; Levis, Aviad; Li, Zhiyuan; Lico, Rocco; Lindahl, Greg; Lindqvist, Michael; Lisakov, Mikhail; Liu, Jun; Liu, Kuo; Liuzzo, Elisabetta; Lo, Wen-Ping; Lobanov, Andrei P.; Loinard, Laurent; Lonsdale, Colin J.; Lu, Ru-Sen; Mao, Jirong; Marchili, Nicola; Markoff, Sera; Marrone, Daniel P.; Marscher, Alan P.; Martí-Vidal, Iván; Matsushita, Satoki; Matthews, Lynn D.; Medeiros, Lia; Menten, Karl M.; Michalik, Daniel; Mizuno, Izumi; Mizuno, Yosuke; Moran, James M.; Moriyama, Kotaro; Moscibrodzka, Monika; Müller, Cornelia; Mus, Alejandro; Musoke, Gibwa; Myserlis, Ioannis; Nadolski, Andrew; Nagai, Hiroshi; Nagar, Neil M.; Nakamura, Masanori; Narayan, Ramesh; Narayanan, Gopal; Natarajan, Iniyani; Nathanail, Antonios; Fuentes, Santiago Navarro; Neilsen, Joey; Neri, Roberto; Ni, Chunchong; Noutsos, Aristeidis; Nowak, Michael A.; Oh, Junghwan; Okino, Hiroki; Olivares, Héctor; Ortiz-León, Gisela N.; Oyama, Tomoaki; Palumbo, Daniel C. M.; Paraschos, Georgios Filippous; Park, Jongho; Parsons, Harriet; Patel, Nimesh; Pen, Ue-Li; Pesce, Dominic W.; Piétu, Vincent; Plambeck, Richard; Popstefanija, Aleksandar; Porth, Oliver; Pötzl, Felix M.; Prather, Ben; Preciado-López, Jorge A.; Pu, Hung-Yi; Ramakrishnan, Venkatesh; Rao, Ramprasad; Rawlings, Mark G.; Raymond, Alexander W.; Rezzolla, Luciano; Ricarte, Angelo; Ripperda, Bart; Roelofs, Freek; Rogers, Alan; Ros, Eduardo; Romero-Cañizales,

- Daniel C. M.; Paraschos, Georgios; Filippou, Park, Jongho; Parsons, Harriet; Patel, Nimesh; Pen, Ue-Li; Pesce, Dominic W.; Piétu, Vincent; Plambeck, Richard; Popstefanija, Aleksandar; Porth, Oliver; Pözl, Felix M.; Prather, Ben; Preciado-López, Jorge A.; Psaltis, Dimitrios; Pu, Hung-Yi; Ramakrishnan, Venkatesh; Rao, Ramprasad; Rawlings, Mark G.; Raymond, Alexander W.; Rezzolla, Luciano; Ricarte, Angelo; Ripperda, Bart; Roelofs, Freek; Rogers, Alan; Ros, Eduardo; Romero-Cañizales, Cristina; Roshanineshat, Arash; Rottmann, Helge; Roy, Alan L.; Ruiz, Ignacio; Ruszczyk, Chet; Rygl, Kazi L. J.; Sánchez, Salvador; Sánchez-Argüelles, David; Sánchez-Portal, Miguel; Sasada, Mahito; Satapathy, Kaushik; Savolainen, Tuomas; Schloerb, F. Peter; Schonfeld, Jonathan; Schuster, Karl-Friedrich; Shao, Lijing; Shen, Zhiqiang; Small, Des; Sohn, Bong Won; Soohoo, Jason; Souccar, Kamal; Sun, He; Tazaki, Fumie; Tetarenko, Alexandra J.; Tiede, Paul; Tilanus, Remo P. J.; Titus, Michael; Torne, Pablo; Traianou, Efthalia; Trent, Tyler; Trippe, Sascha; Turk, Matthew; Van Bemmel, Ilse; Van Langevelde, Huib Jan; Van Rossum, Daniel R.; Vos, Jesse; Wagner, Jan; Ward-Thompson, Derek; Wardle, John; Weintraub, Jonathan; Wex, Norbert; Wharton, Robert; Wielgus, Maciek; Wiik, Kaj; Witzel, Gunther; Wondrak, Michael F.; Wong, George N.; Wu, Qingwen; Yamaguchi, Paul; Yoon, Doosoo; Young, André; Young, Ken; Younsi, Ziri; Yuan, Feng; Yuan, Ye-Fei; Zensus, J. Anton; Zhang, Shuo; Zhao, Guang-Yao; Zhao, Shan-Shan "First Sagittarius A" Event Horizon Telescope Results. VI. Testing the Black Hole Metric," *The Astrophysical Journal*, 930: L17, 2022.
- Akiyama, Kazunori; Alberdi, Anton; Alef, Walter; Carlos Algaba, Juan; Anantua, Richard; Asada, Keiichi; Azulay, Rebecca; Bach, Uwe; Baczko, Anne-Kathrin; Ball, David; Baloković, Mislav; Barrett, John; Bauböck, Michi; Benson, Bradford A.; Bintley, Dan; Blackburn, Lindy; Blundell, Raymond; Bouman, Katherine L.; Bower, Geoffrey C.; Boyce, Hope; Bremer, Michael; Brinkerink, Christiaan D.; Brissenden, Roger; Britzen, Silke; Broderick, Avery E.; Brogiere, Dominique; Bronzwaer, Thomas; Bustamante, Sandra; Byun, Do-Young; Carlstrom, John E.; Ceccobello, Chiara; Chael, Andrew; Chan, Chi-Kwan; Chatterjee, Koushik; Chatterjee, Shami; Chen, Ming-Tang; Chen, Yongjun; Cheng, Xiaopeng; Cho, Ilje; Christian, Pierre; Conroy, Nicholas S.; Conway, John E.; Cordes, James M.; Crawford, Thomas M.; Crew, Geoffrey B.; Cruz-Osorio, Alejandro; Cui, Yuzhu; Davelaar, Jordy; De Laurentis, Mariafelicia; Deane, Roger; Dempsey, Jessica; Desvignes, Gregory; Dexter, Jason; Dhruv, Vedant; Doeleman, Sheperd S.; Dougal, Sean; Dzib, Sergio A.; Eatough, Ralph P.; Emami, Razieh; Falcke, Heino; Farah, Joseph; Fish, Vincent L.; Fomalont, Ed; Ford, H. Alyson; Fraga-Encinas, Raquel; Freeman, William T.; Friberg, Per; Fromm, Christian M.; Fuentes, Antonio; Galison, Peter; Gammie, Charles F.; García, Roberto; Gentaz, Olivier; Georgiev, Boris; Goddi, Ciriaco; Gold, Roman; Gómez-Ruiz, Arturo I.; Gómez, José L.; Gu, Minfeng; Gurwell, Mark; Hada, Kazuhiro; Haggard, Daryl; Haworth, Kari; Hecht, Michael H.; Hesper, Ronald; Heumann, Dirk; Ho, Luis C.; Ho, Paul; Honma, Mareki; Huang, Chih-Wei L.; Huang, Lei; Hughes, David H.; Ikeda, Shiro; Violette Impellizzeri, C. M.; Inoue, Makoto; Issaoun, Sara; James, David J.; Jannuzi, Buell T.; Janssen, Michael; Jeter, Britton; Jiang, Wu; Jiménez-Rosales, Alejandra; Johnson, Michael D.; Jorstad, Svetlana; Joshi, Abhishek V.; Jung, Taehyun; Karami, Mansour; Karuppusamy, Ramesh; Kawashima, Tomohisa; Keating, Garrett K.; Kettenis, Mark; Kim, Dong-Jin; Kim, Jae-Young; Kim, Jongsoo; Kim, Junhan; Kino, Motoki; Koay, Jun Yi; Kocherlakota, Prashant; Kofuji, Yutaro; Koch, Patrick M.; Koyama, Shoko; Kramer, Carsten; Kramer, Michael; Krichbaum, Thomas P.; Kuo, Cheng-Yu; Bella, Noemi La; Lauer, Tod R.; Lee, Daeyoung; Lee, Sang-Sung; Leung, Po Kin; Levis, Aviad; Li, Zhiyuan; Lico, Rocco; Lindahl, Greg; Lindqvist, Michael; Lisakov, Mikhail; Liu, Jun; Liu, Kuo; Luzzo, Elisabetta; Lo, Wen-Ping; Lobanov, Andrei P.; Loinard, Laurent; Lonsdale, Colin J.; Lu, Ru-Sen; Mao, Jirong; Marchili, Nicola; Markoff, Sera; Marrone, Daniel P.; Marscher, Alan P.; Martí-Vidal, Iván; Matsushita, Satoki; Matthews, Lynn D.; Medeiros, Lia; Menten, Karl M.; Michalik, Daniel; Mizuno, Izumi; Mizuno, Yosuke; Moran, James M.; Moriyama, Kotaro; Moscibrodzka, Monika; Müller, Cornelia; Mus, Alejandro; Musoke, Gibwa; Myserlis, Ioannis; Nadolski, Andrew; Nagai, Hiroshi; Nagar, Neil M.; Nakamura, Masanori; Narayan, Ramesh; Narayanan, Gopal; Natarajan, Iniyar; Nathanail, Antonios; Navarro Fuentes, Santiago; Neilsen, Joey; Neri, Roberto; Ni, Chunchong; Noutsos, Aristeidis; Nowak, Michael A.; Oh, Junghwan; Okino, Hiroki; Olivares, Héctor; Ortiz-León, Gisela N.; Oyama, Tomoaki; Özel, Feryal; Palumbo, Daniel C. M.; Filippou Paraschos, Georgios; Park, Jongho; Parsons, Harriet; Patel, Nimesh; Pen, Ue-Li; Pesce, Dominic W.; Piétu, Vincent; Plambeck, Richard; Popstefanija, Aleksandar; Porth, Oliver; Pözl, Felix M.; Prather, Ben; Preciado-López, Jorge A.; Psaltis, Dimitrios; Pu, Hung-Yi; Ramakrishnan, Venkatesh; Rao, Ramprasad; Rawlings, Mark G.; Raymond, Alexander W.; Rezzolla, Luciano; Ricarte, Angelo; Ripperda, Bart; Roelofs, Freek; Rogers, Alan; Ros, Eduardo; Romero-Cañizales, Cristina; Roshanineshat, Arash; Rottmann, Helge; Roy, Alan L.; Ruiz, Ignacio; Ruszczyk, Chet; Rygl, Kazi L. J.; Sánchez, Salvador; Sánchez-Argüelles, David; Sánchez-Portal, Miguel; Sasada, Mahito; Satapathy, Kaushik; Savolainen, Tuomas; Schloerb, F. Peter; Schonfeld, Jonathan; Schuster, Karl-Friedrich; Shao, Lijing; Shen, Zhiqiang; Small, Des; Sohn, Bong Won; Soohoo, Jason; Souccar, Kamal; Sun, He; Tazaki, Fumie; Tetarenko, Alexandra J.; Tiede, Paul; Tilanus, Remo P. J.; Titus, Michael; Torne, Pablo; Traianou, Efthalia; Trent, Tyler; Trippe, Sascha; Turk, Matthew; Van Bemmel, Ilse; Van Langevelde, Huib Jan; Van Rossum, Daniel R.; Vos, Jesse; Wagner, Jan; Ward-Thompson, Derek; Wardle, John; Weintraub, Jonathan; Wex, Norbert; Wharton, Robert; Wielgus, Maciek; Wiik, Kaj; Witzel, Gunther; Wondrak, Michael F.; Wong, George N.; Wu, Qingwen; Yamaguchi, Paul; Yoon, Doosoo; Young, André; Young, Ken; Younsi, Ziri; Yuan, Feng; Yuan, Ye-Fei; Zensus, J. Anton; Zhang, Shuo; Zhao, Guang-Yao; Zhao, Shan-Shan "First Sagittarius A" Event Horizon Telescope Results. V. Testing Astrophysical Models of the Galactic Center Black Hole," *The Astrophysical Journal*, 930: L16, 2022.
- Alarcón, Felipe; Bergin, Edwin A.; Teague, Richard "A Localized Kinematic Structure Detected in Atomic Carbon Emission Spatially Coincident with a Proposed Protoplanet in the HD 163296 Disk," *The Astrophysical Journal*, 941: L24, 2022.
- Alberts, Stacey; Adams, Jéa; Gregg, Benjamin; Pope, Alexandra; Williams, Christina C.; Eisenhardt, Peter R. M. "Significant Molecular Gas Deficiencies in Star-forming Cluster Galaxies at  $z \sim 1.4$ ," *The Astrophysical Journal*, 927: 235, 2022.
- Algera, Hiddo S. B.; Hodge, Jacqueline A.; Riechers, Dominik A.; Leslie, Sarah K.; Smail, Ian; Aravena, Manuel; Cunha, Elisabete Da; Daddi, Emanuele; Decarli, Roberto; Dickinson, Mark; Gim, Hansung B.; Guaita, Lucia; Magnelli, Benjamin; Murphy, Eric J.; Pavesi, Riccardo; Sargent, Mark T.; Sharon, Chelsea E.; Wagg, Jeff; Walter, Fabiano; Yun, Min "COLDz: Probing Cosmic Star Formation With Radio Free-Free Emission," *The Astrophysical Journal*, 924: 76, 2022.
- Alhosani, Abdulla; Gelfand, Joseph D.; Zaw, Ingyin; Laor, Ari; Behar, Ehud; Chen, Sina; Wrzosek, Ramon "Dependence of the Radio Emission on the Eddington Ratio of Radio-quiet Quasars," *The Astrophysical Journal*, 936: 73, 2022.
- Alissandrakis, C. E.; Bastian, T. S.; Nindos, A. "A first look at the submillimeter Sun with ALMA," *Astronomy and Astrophysics*, 661: L4, 2022.
- Alissandrakis, Costas E.; Bastian, T. S.; Brajša, Roman "The quiet sun at mm wavelengths as seen by ALMA," *Frontiers in Astronomy and Space Sciences*, 9: 981320, 2022.
- Allison, James R.; Sadler, E. M.; Amaral, A. D.; An, T.; Curran, S. J.; Darling, J.; Edge, A. C.; Ellison, S. L.; Emig, K. L.; Gaensler, B. M.; Garratt-Smithson, L.; Glowacki, M.; Grasha, K.; Koribalski, B. S.; Lagos, C. Del P.; Lah, P.; Mahony, E. K.; Mao, S. A.; Morganti, R.; Moss, V. A.; Pettini, M.; Pimblett, K. A.; Power, C.; Salas, P.; Staveley-Smith, L.; Whiting, M. T.; Wong, O. I.; Yoon, H.; Zheng, Z.; Zwaan, M. A. "The First Large Absorption Survey in H I (FLASH): I. Science goals and survey design," *Publications of the Astronomical Society of Australia*, 39: e010, 2022.
- Amada, K.; Imai, H.; Hamae, Y.; Nakashima, K.; Shum, K. Y.; Tafoya, D.; Uscanga, L.; Gómez, J. F.; Orosz, G.; Burns, R. A. "Discovery of SiO

## APPENDIX A: PUBLICATIONS

- Masers in the "Water Fountain" Source IRAS 16552-3050," *The Astronomical Journal*, 163: 85, 2022.
- An, Tao; Wang, Ailing; Zhang, Yingkang; Aditya, J. N. H. S.; Hong, Xiaoyu; Cui, Lang "A compact symmetric radio source born at one-tenth the current age of the Universe," *Monthly Notices of the Royal Astronomical Society*, 511: 4572, 2022.
- An, Tao; Zhang, Yingkang; Wang, Ailing; Shu, Xinwen; Yang, Huan; Jiang, Ning; Dou, Liming; Pan, Zhen; Wang, Tinggui; Zheng, Zhenya "VLBI imaging of the pre-coalescence SMBHB candidate SDSS J143016.05+230344.4," *Astronomy and Astrophysics*, 663: A139, 2022.
- Anderson, Alexa R.; Williams, Jonathan P.; Marel, Nienke Van Der; Law, Charles J.; Ricci, Luca; Tobin, John J.; Tong, Simin "Protostellar and Protoplanetary Disk Masses in the Serpens Region," *The Astrophysical Journal*, 938: 55, 2022.
- Anderson, Craig S.; Carilli, Christopher L.; Tozzi, Paolo; Miley, G. K.; Borgani, S.; Clarke, Tracy; Di Mascio, Luca; Liu, Ang; Mroczkowski, Tony; Pannella, Maurilio; Pentericci, L.; Rottgering, H. J. A.; Saro, A. "The Spiderweb Protocluster is Being Magnetized by Its Central Radio Jet," *The Astrophysical Journal*, 937: 45, 2022.
- Anderson, Dana E.; Cleeves, L. Isedore; Blake, Geoffrey A.; Bergin, Edwin A.; Zhang, Ke; Carpenter, John M.; Schwarz, Kamber R. "New Constraints on Protoplanetary Disk Gas Masses in Lupus," *The Astrophysical Journal*, 927: 229, 2022.
- Andika, Irfham Taufik; Jahnke, Knud; Bañados, Eduardo; Bosman, Sarah E. I.; Davies, Frederick B.; Eilers, Anna-Christina; Farina, Emanuele Paolo; Onoue, Masafusa; Van Der Wel, Arjen "Staring at the Shadows of Archaic Galaxies: Damped Ly $\alpha$  and Metal Absorbers Toward a Young z = 6 Weak-line Quasar," *The Astronomical Journal*, 163: 251, 2022.
- Andreoni, Igor; Coughlin, Michael W.; Perley, Daniel A.; Yao, Yuhang; Lu, Wenbin; Cenko, S. Bradley; Kumar, Harsh; Anand, Shreya; Ho, Anna Y. Q.; Kasliwal, Mansi M.; De Ugarte Postigo, Antonio; Sagués-Carracedo, Ana; Schulze, Steve; Kann, D. Alexander; Kulkarni, S. R.; Sollerman, Jesper; Tanvir, Nial; Rest, Armin; Izzo, Luca; Samalwar, Jean J.; Kaplan, David L.; Ahumada, Tomás; Anupama, G. C.; Auchettl, Katie; Barway, Sudhanshu; Bellm, Eric C.; Bhalerao, Varun; Bloom, Joshua S.; Bremer, Michael; Bulla, Mattia; Burns, Eric; Campana, Sergio; Chandra, Poonam; Charalampopoulos, Panos; Cooke, Jeff; D'Elia, Valerio; Das, Kaustav Kashyap; Dobie, Dougal; Agúí Fernández, José Feliciano; Freeburn, James; Fremling, Cristoffer; Gezari, Suvi; Goode, Simon; Graham, Matthew J.; Hammerstein, Erica; Karambelkar, Viraj R.; Kilpatrick, Charles D.; Kool, Erik C.; Krips, Melanie; Laher, Russ R.; Leloudas, Giorgos; Levan, Andrew; Lundquist, Michael J.; Mahabal, Ashish A.; Medford, Michael S.; Miller, M. Coleman; Möller, Anais; Mooley, Kunal P.; Nayana, A. J.; Nir, Guy; Pang, Peter T. H.; Paraskeva, Emmy; Perley, Richard A.; Petipapas, Glen; Pursiainen, Miika; Ravi, Vikram; Ridden-Harper, Ryan; Riddle, Reed; Rigault, Mickael; Rodriguez, Antonio C.; Rusholme, Ben; Sharma, Yashvi; Smith, I. A.; Stein, Robert D.; Thöne, Christina; Tohuvavohu, Aaron; Valdes, Frank; Van Roestel, Jan; Vergani, Susanna D.; Wang, Qinan; Zhang, Jielai "A very luminous jet from the disruption of a star by a massive black hole," *Nature*, 612: 430, 2022.
- Ansarinejad, B.; Shanks, T.; Bielby, R. M.; Metcalfe, N.; Infante, L.; Murphy, D. N. A.; Rosario, D. J.; Stach, S. M. "The nature of sub-millimetre galaxies II: an ALMA comparison of SMG dust heating mechanisms," *Monthly Notices of the Royal Astronomical Society*, 510: 4976, 2022.
- Antoniadis, J.; Arzoumanian, Z.; Babak, S.; Bailes, M.; Bak Nielsen, A.-S.; Baker, P. T.; Bassa, C. G.; Bécsy, B.; Berthreau, A.; Bonetti, M.; Brazier, A.; Brook, P. R.; Burgay, M.; Burke-Spolaor, S.; Caballero, R. N.; Casey-Clyde, J. A.; Chalumeau, A.; Champion, D. J.; Charisi, M.; Chatterjee, S.; Chen, S.; Cognard, I.; Cordes, J. M.; Cornish, N. J.; Crawford, F.; Cromartie, H. T.; Crowter, K.; Dai, S.; Decesar, M. E.; Demorest, P. B.; Desvignes, G.; Dolch, T.; Drachler, B.; Falxa, M.; Ferrara, E. C.; Fiore, W.; Fonseca, E.; Gair, J. R.; Garver-Daniels, N.; Goncharov, B.; Good, D. C.; Graikou, E.; Guillemot, L.; Guo, Y. J.; Hazboun, J. S.; Hobbs, G.; Hu, H.; Islo, K.; Janssen, G. H.; Jennings, R. J.; Johnson, A. D.; Jones, M. L.; Kaiser, A. R.; Kaplan, D. L.; Karuppusamy, R.; Keith, M. J.; Kelley, L. Z.; Kerr, M.; Key, J. S.; Kramer, M.; Lam, M. T.; Lamb, W. G.; Lazio, T. J. W.; Lee, K. J.; Lentati, L.; Liu, K.; Luo, J.; Lynch, R. S.; Lyne, A. G.; Madison, D. R.; Main, R. A.; Manchester, R. N.; McEwen, A.; Mckee, J. W.; McLaughlin, M. A.; Mickaliger, M. B.; Mingarelli, C. M. F.; Ng, C.; Nice, D. J.; Osłowski, S.; Parthasarathy, A.; Pennucci, T. T.; Perera, B. B. P.; Perrodin, D.; Petiteau, A.; Pol, N. S.; Porayko, N. K.; Possenti, A.; Ransom, S. M.; Ray, P. S.; Reardon, D. J.; Russell, C. J.; Samajdar, A.; Sampson, L. M.; Sanidas, S.; Sarkissian, J. M.; Schmitz, K.; Schult, L.; Sesana, A.; Shaifullah, G.; Shannon, R. M.; Shapiro-Albert, B. J.; Siemens, X.; Simon, J.; Smith, T. L.; Speri, L.; Spiewak, R.; Stairs, I. H.; Stappers, B. W.; Stinebring, D. R.; Swiggum, J. K.; Taylor, S. R.; Theureau, G.; Tiburzi, C.; Vallisneri, M.; Van Der Wateren, E.; Vecchio, A.; Verbiest, J. P. W.; Vigeland, S. J.; Wahl, H.; Wang, J. B.; Wang, J.; Wang, L.; Witt, C. A.; Zhang, S.; Zhu, X. J. "The International Pulsar Timing Array second data release: Search for an isotropic gravitational wave background," *Monthly Notices of the Royal Astronomical Society*, 510: 4873, 2022.
- Antonio Garcia-Barreto, J.; Momjian, Emmanuel "Obar in NGC 5597 from Very Large Array H I 21 cm Observations," *The Astronomical Journal*, 164: 91, 2022.
- Aoyama, Kohei; Kodama, Tadayuki; Suzuki, Tomoko L.; Tadaki, Ken-Ichi; Shimakawa, Rhythm; Hayashi, Masao; Koyama, Yusei; Pérez-Martínez, Jose Manuel "The Environmental Dependence of Gas Properties in Dense Cores of a Protocluster at z = 2.5 Revealed with ALMA," *The Astrophysical Journal*, 924: 74, 2022.
- Appleton, P. N.; Emonts, B.; Lisenfeld, U.; Falgarone, E.; Guillard, P.; Boulanger, F.; Braine, J.; Ogle, P.; Struck, C.; Vollmer, B.; Yeager, T. "The CO Emission in the Taffy Galaxies (UGC 12914/15) at 60 pc Resolution. I. The Battle for Star Formation in the Turbulent Taffy Bridge," *The Astrophysical Journal*, 931: 121, 2022.
- Arabsalmani, M.; Roychowdhury, S.; Renaud, F.; Burkert, A.; Emsellem, E.; Le Floch, E.; Pian, E. "Unusual Gas Structure in an Otherwise Normal Spiral Galaxy Hosting GRB 171205A/SN 2017iuk," *The Astronomical Journal*, 164: 69, 2022.
- Araya, M.; Hurley-Walker, N.; Quirós-Araya, S. "G17.8+16.7: A New Supernova Remnant," *Monthly Notices of the Royal Astronomical Society*, 510: 2920-2927, 2022.
- Archer, Haylee N.; Hunter, Deidre A.; Elmegreen, Bruce G.; Cigan, Phil; Jansen, Rolf A.; Windhorst, Rogier A.; Hunt, Leslie K.; Rubio, Monica "The Environments of CO Cores and Star Formation in the Dwarf Irregular Galaxy WLM," *The Astronomical Journal*, 163: 141, 2022.
- Arrigoni Battaia, Fabrizio; Chen, Chian-Chou; Liu, Hau-Yu Baobab; De Breuck, Carlos; Galametz, Maud; Fumagalli, Michele; Yang, Yujin; Zanella, Anita; Man, Allison; Obreja, Aura; Prochaska, J. Xavier; Bañados, Eduardo; Hennawi, Joseph F.; Farina, Emanuele P.; Zwaan, Martin A.; Decarli, Roberto; Lusso, Elisabeta "A Multiwavelength Study of ELAN Environments (AMUSE2). Mass Budget, Satellites Spin Alignment, and Gas Infall in a Massive z = 3 Quasar Host Halo," *The Astrophysical Journal*, 930: 72, 2022.
- Artur De La Villarmois, E.; Guzmán, V. V.; Jørgensen, J. K.; Kristensen, L. E.; Bergin, E. A.; Harsono, D.; Sakai, N.; Van Dishoeck, E. F.; Yamamoto, S. "Physical properties of accretion shocks toward the Class I protostellar system Oph-IRS 44," *Astronomy and Astrophysics*, 667: A20, 2022.
- Ashley, Trisha; Fox, Andrew J.; Cashman, Frances H.; Lockman, Felix J.; Bordoloi, Rongmon; Jenkins, Edward B.; Wakker, Bart P.; Karim, Tanveer "Diverse metallicities of Fermi bubble clouds indicate dual origins in the disk and halo," *Nature Astronomy*, 6: p. 968-975, 2022.
- Astropy Collaboration; Price-Whelan, Adrian M.; Lim, Pey Lian; Earl, Nicholas; Starkman, Nathaniel; Bradley, Larry; Shupe, David L.; Patil, Aarya A.; Corrales, Lia; Brasseur, C. E.; Nöthe, Maximilian; Donath, Axel; Tollerud, Erik; Morris, Brett M.; Ginsburg, Adam; Vaher, Eero; Weaver, Benjamin A.; Tocknell, James; Jamieson, William; Van Kerkwijk, Marten H.; Robitaille, Thomas P.; Merry, Bruce; Bachetti, Matteo; Günther, H. Moritz; Aldcroft, Thomas L.; Alvarado-Montes, Jaime A.; Archibald, Anne M.; Bódi, Attila; Bapat, Shreyas; Barentsen, Geert; Bazán, Juanjo; Biswas, Manish; Boquien, Médéric; Burke, D. J.; Cara, Daria; Cara, Mihai; Conroy, Kyle

- E.; Conseil, Simon; Craig, Matthew W.; Cross, Robert M.; Cruz, Kelle L.; D'Eugenio, Francesco; Dencheva, Nadia; Devillepoix, Hadrien A. R.; Dietrich, Jörg P.; Eigenbrot, Arthur Davis; Erben, Thomas; Ferreira, Leonardo; Foreman-Mackey, Daniel; Fox, Ryan; Freij, Nabil; Garg, Suyog; Geda, Robel; Glatty, Lauren; Gondhalekar, Yash; Gordon, Karl D.; Grant, David; Greenfield, Perry; Groener, Austen M.; Guest, Steve; Gurovich, Sebastian; Handberg, Rasmus; Hart, Akeem; Hatfield-Dodds, Zac; Homeier, Derek; Hosseinzadeh, Griffin; Jenness, Tim; Jones, Craig K.; Joseph, Prajwel; Kalmbach, J. Bryce; Karamehmetoglu, Emir; Kałuszyński, Mikołaj; Kelley, Michael S. P.; Kern, Nicholas; Kerzendorf, Wolfgang E.; Koch, Eric W.; Kulumani, Shankar; Lee, Antony; Ly, Chun; Ma, Zhiyuan; Macbride, Conor; Maljaars, Jakob M.; Muna, Demitri; Murphy, N. A.; Norman, Henrik; O'Steen, Richard; Oman, Kyle A.; Pacifici, Camilla; Pascual, Sergio; Pascual-Granado, J.; Patil, Rohit R.; Perren, Gabriel I.; Pickering, Timothy E.; Rastogi, Tanuj; Roulston, Benjamin R.; Ryan, Daniel F.; Rykoff, Eli S.; Sabater, Jose; Sakurikar, Parikshit; Salgado, Jesús; Sanghi, Aniket; Saunders, Nicholas; Savchenko, Volodymyr; Schwardt, Ludwig; Seifert-Eckert, Michael; Shih, Albert Y.; Jain, Anany Shrey; Shukla, Gyanendra; Sick, Jonathan; Simpson, Chris; Singanamalla, Sudheesh; Singer, Leo P.; Singhal, Jaladh; Sinha, Manodeep; Siṓcz, Brigitta M.; Spitler, Lee R.; Stansby, David; Streicher, Ole; Šumak, Jani; Swinbank, John D.; Taranu, Dan S.; Tewary, Nikita; Tremblay, Grant R.; Val-Borro, Miguel De; Van Kooten, Samuel J.; Vasočić, Zlatan; Verma, Shresth; De Miranda Cardoso, José Vinícius; Williams, Peter K. G.; Wilson, Tom J.; Winkel, Benjamin; Wood-Vasey, W. M.; Xue, Rui; Yoachim, Peter; Zhang, Chen; Zonca, Andrea; Astropy Project Contributors "The Astropy Project: Sustaining and Growing a Community-oriented Open-source Project and the Latest Major Release (v5.0) of the Core Package," *The Astrophysical Journal*, 935: 167, 2022.
- Atri, P.; Miller-Jones, J. C. A.; Bahramian, A.; Plotkin, R. M.; Maccarone, T. J.; Marcote, B.; Heinke, C. O.; Sivakoff, G. R.; Ginsburg, A.; Strader, J.; Chomiuk, L. "Astrometry of variable compact radio sources: a search for Galactic black hole X-ray binaries," *Monthly Notices of the Royal Astronomical Society*, 517: 5810, 2022.
- Audibert, A.; Dasra, K. M.; Papachristou, M.; Fernández-Ontiveros, J. A.; Ruffa, I.; Bisigello, L.; Combes, F.; Salomé, P.; Gruppioni, C. "CO in the ALMA Radio-source Catalogue (ARC): The molecular gas content of radio galaxies as a function of redshift," *Astronomy and Astrophysics*, 668: A67, 2022.
- Aydi, E.; Sokolovsky, K. V.; Bright, J. S.; Tremou, E.; Nyamai, M. M.; Evans, A.; Strader, J.; Chomiuk, L.; Myers, G.; Hamsch, F.-J.; Page, K. L.; Buckley, D. A. H.; Woodward, C. E.; Walter, F. M.; Mróz, P.; Vallely, P. J.; Geballe, T. R.; Banerjee, D. P. K.; Gehrz, R. D.; Fender, R. P.; Gromadzki, M.; Kawash, A.; Knigge, C.; Mukai, K.; Munari, U.; Orio, M.; Ribeiro, V. A. R. M.; Sokoloski, J. L.; Starrfield, S.; Udalski, A.; Woudt, P. A. "The 2019 Outburst of the 2005 Classical Nova V1047 Cen: A Record Breaking Dwarf Nova Outburst or a New Phenomenon?," *The Astrophysical Journal*, 939: 6, 2022.
- Baan, Willem A.; An, Tao; Henkel, Christian; Imai, Hiroshi; Kostenko, Vladimir; Sobolev, Andrej "H<sub>2</sub>O MegaMaser emission in NGC 4258 indicative of a periodic disc instability," *Nature Astronomy*, 6: 976, 2022.
- Baba, Shunsuke; Imanishi, Masatoshi; Izumi, Takuma; Kawamuro, Taiki; Nguyen, Dieu D.; Nakagawa, Takao; Isobe, Naoki; Onishi, Shusuke; Matsumoto, Kosei "The Extremely Buried Nucleus of IRAS 17208-0014 Observed at Submillimeter and Near-infrared Wavelengths," *The Astrophysical Journal*, 928: 184, 2022.
- Babul, Aliya-Nur; Sokoloski, Jennifer L.; Chomiuk, Laura; Linford, Justin D.; Weston, Jennifer H. S.; Aydi, Elias; Sokolovsky, Kirill V.; Kawash, Adam M. "Shocks and dust formation in Nova V809 Cep," *Monthly Notices of the Royal Astronomical Society*, 515: 3028, 2022.
- Baczko, A.-K.; Ros, E.; Kadler, M.; Fromm, C. M.; Boccardi, B.; Perucho, M.; Krichbaum, T. P.; Burd, P. R.; Zensus, J. A. "Ambilateral collimation study of the twin-jets in NGC 1052," *Astronomy and Astrophysics*, 658: A119, 2022.
- Bae, Jaehan; Teague, Richard; Andrews, Sean M.; Benisty, Myriam; Facchini, Stefano; Galloway-Sprietsma, Maria; Loomis, Ryan A.; Aikawa, Yuri; Alarcón, Felipe; Bergin, Edwin; Bergner, Jennifer B.; Booth, Alice S.; Cataldi, Gianni; Cleeves, L. Isedore; Czekala, Ian; Guzmán, Viviana V.; Huang, Jane; Ilee, John D.; Kurtovic, Nicolas T.; Law, Charles J.; Gal, Romane Le; Liu, Yao; Long, Feng; Ménard, François; Öberg, Karin I.; Pérez, Laura M.; Qi, Chunhua; Schwarz, Kamber R.; Sierra, Anibal; Walsh, Catherine; Wilner, David J.; Zhang, Ke "Molecules with ALMA at Planet-forming Scales (MAPS): A Circumplanetary Disk Candidate in Molecular-line Emission in the AS 209 Disk," *The Astrophysical Journal*, 934: L20, 2022.
- Baek, Giseon; Lee, Jeong-Eun; Hirota, Tomoya; Kim, Kee-Tae; Kyoung Kim, Mi "Complex Organic Molecules Detected in 12 High-mass Star-forming Regions with Atacama Large Millimeter/submillimeter Array," *The Astrophysical Journal*, 939: 84, 2022.
- Baek, Junhyun; Chung, Aeree; Edge, Alastair; Rose, Tom; Kim, Jae-Woo; Jung, Taehyun "Circumnuclear Medium around the Central AGN in a Cool-core Cluster, Abell 1644-South," *The Astrophysical Journal*, 932: 64, 2022.
- Baker, Daniel; Briske, Walter; Van Kerkwijk, Marten H.; Main, Robert; Pen, Ue-Li; Sprenger, Tim; Wucknitz, Olaf "Interstellar interferometry: Precise curvature measurement from pulsar secondary spectra," *Monthly Notices of the Royal Astronomical Society*, 510: 4573, 2022.
- Baker, William M.; Maiolino, Roberto; Bluck, Asa F. L.; Lin, Lihwai; Ellison, Sara L.; Belfiore, Francesco; Pan, Hsi-An; Thorp, Mallory "The ALMaQUEST survey IX: the nature of the resolved star forming main sequence," *Monthly Notices of the Royal Astronomical Society*, 510: 3622, 2022.
- Balasubramanian, Arvind; Corsi, Alessandra; Mooley, Kunal P.; Hotokezaka, Kenta; Kaplan, David L.; Frail, Dale A.; Hallinan, Gregg; Lazzati, Davide; Murphy, Eric J. "GW170817 4.5 Yr After Merger: Dynamical Ejecta Afterglow Constraints," *The Astrophysical Journal*, 938: 12, 2022.
- Baldi, R. D.; Laor, A.; Behar, E.; Horesh, A.; Panessa, F.; Mchardy, I.; Kimball, A. "The PG-RQS survey. Building the radio spectral distribution of radio-quiet quasars. I. The 45-GHz data," *Monthly Notices of the Royal Astronomical Society*, 510: 1043, 2022.
- Balmaverde, B.; Capetti, A.; Baldi, R. D.; Baum, S.; Chiaberge, M.; Gilli, R.; Jimenez-Gallardo, A.; Marconi, A.; Massaro, F.; Meyer, E.; O'Dea, C.; Speranza, G.; Torresi, E.; Venturi, G. "The MURALES survey. VI. Properties and origin of the extended line emission structures in radio galaxies," *Astronomy and Astrophysics*, 662: A23, 2022.
- Balsler, Dana S. "The diffuse ionized gas in the Milky Way galaxy," *Science China Physics, Mechanics, and Astronomy*, 65: 129707, 2022.
- Balsler, Dana S.; Wenger, Trey V.; Bania, T. M. "Do All Low-Mass Stars Undergo Extra Mixing Processes?," *The Astrophysical Journal*, 936: 168, 2022.
- Barfety, Capucine; Valin, Félix-Antoine; Webb, Tracy M. A.; Yun, Min; Shipley, Heath; Boone, Kyle; Hayden, Brian; Hlavacek-Larrondo, Julie; Muzzin, Adam; Noble, Allison G.; Perlmutter, Saul; Rhea, Carter; Wilson, Gillian; Yee, H. K. C. "An Assessment of the In Situ Growth of the Intracluster Light in the High-redshift Galaxy Cluster SpARCS1049+56," *The Astrophysical Journal*, 930: 25, 2022.
- Barger, A. J.; Cowie, L. L.; Blair, A. H.; Jones, L. H. "A Submillimeter Perspective on the GOODS Fields (SUPER GOODS). V. Deep 450  $\mu$ m Imaging," *The Astrophysical Journal*, 934: 56, 2022.
- Bariuan, Luis Gabriel C.; Snios, Bradford; Sobolewska, Małgosia; Siemiginowska, Aneta; Schwartz, Daniel A. "The Fundamental Planes of black hole activity for radio-loud and radio-quiet quasars," *Monthly Notices of the Royal Astronomical Society*, 513: 4673, 2022.
- Barnum, Timothy J.; Siebert, Mark A.; Lee, Kin Long Kelvin; Loomis, Ryan A.; Changala, P. Bryan; Charnley, Steven B.; Sita, Madelyn L.; Xue, Ci; Remijan, Anthony J.; Burkhardt, Andrew M.; Mcguire, Brett A.; Cooke, Ilsa R. "A Search for Heterocycles in GOTHAM Observations of TMC-1," *Journal of Physical Chemistry A*, 126: 2716, 2022.
- Barrett, Paul E. "VLA Observations of the AE Aqr-type Cataclysmic Variable LAMOST J024048.51+195226.9," *The Astronomical Journal*, 163: 58, 2022.

## APPENDIX A: PUBLICATIONS

- Bastian, T. S.; Cotton, W. D.; Hallinan, G. "Radio Emission from UV Cet: Auroral Emission from a Stellar Magnetosphere," *The Astrophysical Journal*, 935: 99, 2022.
- Bastian, T. S.; Shimojo, M.; Bárta, M.; White, S. M.; Iwai, K. "Solar observing with the Atacama large millimeter-submillimeter array," *Frontiers in Astronomy and Space Sciences*, 9: 977368, 2022.
- Basu, Arghyadeep; Roy, Nirupam; Beuther, Henrik; Syed, Jonas; Ott, Jürgen; Soler, Juan D.; Stil, Jeroen; Rugel, Michael R. "Properties of atomic hydrogen gas in the Galactic plane from THOR 21-cm absorption spectra: a comparison with the high latitude gas," *Monthly Notices of the Royal Astronomical Society*, 517: 5063, 2022.
- Battye, R. A.; Darling, J.; McDonald, J. I.; Srinivasan, S. "Towards robust constraints on axion dark matter using PSR J1745-2900," *Physical Review D*, 105: L021305, 2022.
- Bayandina, O. S.; Brogan, C. L.; Burns, R. A.; Caratti O Garatti, A.; Chibueze, J. O.; Van Den Heever, S. P.; Kurtz, S. E.; Macleod, G. C.; Moscadelli, L.; Sobolev, A. M.; Sugiyama, K.; Val'Tts, I. E.; Yonekura, Y. "The evolution of the H<sub>2</sub>O maser emission in the accretion burst source G358.93-0.03," *Astronomy and Astrophysics*, 664: A44, 2022.
- Bayandina, O. S.; Brogan, C. L.; Burns, R. A.; Chen, X.; Hunter, T. R.; Kurtz, S. E.; Macleod, G. C.; Sobolev, A. M.; Sugiyama, K.; Val'Tts, I. E.; Yonekura, Y. "A Multitransition Methanol Maser Study of the Accretion Burst Source G358.93-0.03-MM1," *The Astronomical Journal*, 163: 83, 2022.
- Behrens, Erica; Mangum, Jeffrey G.; Holdship, Jonathan; Viti, Serena; Harada, Nanase; Martín, Sergio; Sakamoto, Kazushi; Muller, Sebastien; Tanaka, Kunihiko; Nakanishi, Kouichiro; Herrero-Illana, Rubén; Yoshimura, Yuki; Aladro, Rebeca; Colzi, Laura; Emig, Kimberly L.; Henkel, Christian; Huang, Ko-Yun; Humire, P. K.; Meier, David S.; Rivilla, Víctor M.; Van Der Werf, Paul P.; Alma Comprehensive High-Resolution Extragalactic Molecular Inventory (Alchemi) Collaboration "Tracing Interstellar Heating: An ALCHEMI Measurement of the HCN Isomers in NGC 253," *The Astrophysical Journal*, 939: 119, 2022.
- Bellochi, E.; Pereira-Santaella, M.; Colina, L.; Labiano, A.; Sánchez-García, M.; Alonso-Herrero, A.; Arribas, S.; García-Burillo, S.; Villar-Martín, M.; Rigopoulou, D.; Valentino, F.; Puglisi, A.; Díaz-Santos, T.; Cazzoli, S.; Usero, A. "Compact molecular gas emission in local LIRGs among low- and high-z galaxies," *Astronomy and Astrophysics*, 664: A60, 2022.
- Belloche, A.; Garrod, R. T.; Zingsheim, O.; Müller, H. S. P.; Menten, K. M. "Interstellar detection and chemical modeling of iso-propanol and its normal isomer," *Astronomy and Astrophysics*, 662: A110, 2022.
- Beltrán, M. T.; Rivilla, V. M.; Cesaroni, R.; Galli, D.; Moscadelli, L.; Ahmadi, A.; Beuther, H.; Etoke, S.; Goddi, C.; Klaassen, P. D.; Kuiper, R.; Kumar, M. S. N.; Lorenzani, A.; Peters, T.; Sánchez-Monge, Á.; Schilke, P.; Van Der Tak, F.; Vigi, S. "The sharp ALMA view of infall and outflow in the massive protocluster G31.41+0.31," *Astronomy and Astrophysics*, 659: A81, 2022.
- Benítez, E.; Jiménez-Bailón, E.; Negrete, C. A.; Ruschel-Dutra, D.; Rodríguez-Espinosa, J. M.; Cruz-González, I.; Rodríguez, L. F.; Chavushyan, V. H.; Marziani, P.; Gutiérrez, L.; González-Martín, O.; Jiang, B. W.; D'Onofrio, M. "Unravelling the nature of the dual AGN in the galaxy pair system IRAS 05589+2828 and 2MASX J06021107 + 2828382," *Monthly Notices of the Royal Astronomical Society*, 516: 5270, 2022.
- Benmahi, B.; Cavalié, T.; Fouchet, T.; Moreno, R.; Lellouch, E.; Bardet, D.; Guerlet, S.; Hue, V.; Spiga, A. "First absolute wind measurements in Saturn's stratosphere from ALMA observations," *Astronomy and Astrophysics*, 666: A117, 2022.
- Beom, Minje; Bizyaev, Dmitry; Walterbos, René A. M.; Chen, Yanmei "SDSS IV MaNGA: characteristics of edge-on galaxies with a counter-rotating gaseous disc," *Monthly Notices of the Royal Astronomical Society*, 516: 3175, 2022.
- Bergner, Jennifer B.; Burkhardt, Andrew M.; Öberg, Karin I.; Rice, Thomas S.; Bergin, Edwin A. "First Images of Phosphorus Molecules toward a Protosolar Analog," *The Astrophysical Journal*, 927: 7, 2022.
- Bergner, Jennifer B.; Shirley, Yancy L.; Jørgensen, Jes K.; Mcguire, Brett; Aalto, Susanne; Anderson, Carrie M.; Chin, Gordon; Gerin, Maryvonne; Hartogh, Paul; Kim, Daewook; Leisawitz, David; Najita, Joan; Schwarz, Kamber R.; Tielens, Alexander G. G. M.; Walker, Christopher K.; Wilner, David J.; Wollack, Edward J. "Astrochemistry with the Orbiting Astronomical Satellite for Investigating Stellar Systems (OASIS)," *Frontiers in Astronomy and Space Sciences*, 8: 246, 2022.
- Berman, Derek A.; Yun, Min S.; Harrington, K. C.; Kamienieski, P.; Lowenthal, J.; Frye, B. L.; Wang, Q. D.; Wilson, G. W.; Aretxaga, I.; Chavez, M.; Cybulski, R.; De La Luz, V.; Erickson, N.; Ferrusca, D.; Hughes, D. H.; Montaña, A.; Narayanan, G.; Sánchez-Argüelles, D.; Schloerb, F. P.; Souccar, K.; Terlevich, E.; Terlevich, R.; Zavala, J. A. "PASSAGES: The large millimeter telescope and ALMA observations of extremely luminous high redshift galaxies identified by the Planck," *Monthly Notices of the Royal Astronomical Society*, 515: 3911, 2022.
- Berné, Olivier; Habart, Émilie; Peeters, Els; Abergel, Alain; Bergin, Edwin A.; Bernard-Salas, Jeronimo; Bron, Emeric; Cami, Jan; Dartois, Emmanuel; Fuente, Asunción; Goicoechea, Javier R.; Gordon, Karl D.; Okada, Yoko; Onaka, Takashi; Robberto, Massimo; Röllig, Markus; Tielens, Alexander G. G. M.; Vicente, Sílvia; Wolfire, Mark G.; Alarcón, Felipe; Boersma, C.; Canin, Amélie; Chown, Ryan; Dicken, Daniel; Languignon, David; Le Gal, Romane; Pound, Marc W.; Trahin, Boris; Simmer, Thomas; Sidhu, Ameet; Van De Putte, Dries; Cuadrado, Sara; Guilloteau, Claire; Margakoudakis, Alexandros; Schefter, Bethany R.; Schirmer, Thiébaud; Cazaux, Stéphanie; Aleman, Isabel; Allamandola, Louis; Auchettl, Rebecca; Antonio Baratta, Giuseppe; Bejaoui, Salma; Bera, Partha P.; Bilalbegović, Goranka; Black, John H.; Boulanger, Francois; Bouwman, Jordy; Brandl, Bernhard; Brechignac, Philippe; Brünken, Sandra; Burkhardt, Andrew; Candian, Alessandra; Cernicharo, Jose; Chabot, Marin; Chakraborty, Shubhadip; Champion, Jason; Colgan, Sean W. J.; Cooke, Ilsa R.; Coutens, Audrey; Cox, Nick L. J.; Demyk, Karine; Donovan Meyer, Jennifer; Engrand, Cécile; Foschino, Sacha; García-Lario, Pedro; Gavilan, Lisseth; Gerin, Maryvonne; Godard, Marie; Gottlieb, Carl A.; Guillard, Pierre; Gusdorf, Antoine; Hartigan, Patrick; He, Jinhua; Herbst, Eric; Hornekaer, Liv; Jäger, Cornelia; Janot-Pacheco, Eduardo; Joblin, Christine; Kaufman, Michael; Kemper, Francisca; Kendrew, Sarah; Kirsanova, Maria S.; Klaassen, Pamela; Knight, Collin; Kwok, Sun; Labiano, Álvaro; Lai, Thomas S.-Y.; Lee, Timothy J.; Lefloch, Bertrand; Le Petit, Franck; Li, Aigen; Linz, Hendrik; Mackie, Cameron J.; Madden, Suzanne C.; Mascetti, Joëlle; Mcguire, Brett A.; Merino, Pablo; Micelotta, Elisabetta R.; Misselt, Karl; Morse, Jon A.; Mulas, Giacomo; Neelamkodan, Naslim; Ohsawa, Ryou; Omont, Alain; Paladini, Roberta; Elisabetta Palumbo, Maria; Pathak, Amit; Pendleton, Yvonne J.; Petrignani, Annemieke; Pino, Thomas; Puga, Elena; Rangwala, Naseem; Rapacioli, Mathias; Ricca, Alessandra; Roman-Duval, Julia; Roser, Joseph; Roueff, Evelyne; Rouillé, Gaël; Salama, Farid; Sales, Dinalva A.; Sandstrom, Karin; Sarre, Peter; Sciamma-O'Brien, Ella; Sellgren, Kris; Shannon, Matthew J.; Shenoy, Sachindev S.; Teyssier, David; Thomas, Richard D.; Togi, Aditya; Verstraete, Laurent; Witt, Adolf N.; Wootten, Alwyn; Ysard, Nathalie; Zettergren, Henning; Zhang, Yong; Zhang, Ziwei E.; Zhen, Junfeng "PDRs4All: A JWST Early Release Science Program on Radiative Feedback from Massive Stars," *Publications of the Astronomical Society of the Pacific*, 134: 054301, 2022.
- Bezanson, Rachel; Spilker, Justin S.; Suess, Katherine A.; Setton, David J.; Feldmann, Robert; Greene, Jenny E.; Kriek, Mariska; Narayanan, Desika; Verrico, Margaret "Now You See It, Now You Don't: Star Formation Truncation Precedes the Loss of Molecular Gas by 100 Myr in Massive Poststarburst Galaxies at z 0.6," *The Astrophysical Journal*, 925: 153, 2022.
- Bhadari, N. K.; Dewangan, L. K.; Ojha, D. K.; Pirogov, L. E.; Maity, A. K. "Simultaneous Evidence of Edge Collapse and Hub-filament Configurations: A Rare Case Study of a Giant Molecular Filament, G45.3+0.1," *The Astrophysical Journal*, 930: 169, 2022.
- Bhandari, Shivani; Heintz, Kasper E.; Aggarwal, Kshitij; Marnoch, Lachlan; Day, Cherie K.; Sydnor, Jessica; Burke-Spolaor, Sarah; Law, Casey J.; Xavier Prochaska, J.; Tejos, Nicolas; Bannister, Keith W.; Butler, Bryan J.; Deller, Adam T.; Ekers, R. D.; Flynn, Chris; Fong, Wen-Fai; James, Clancy



- W.; Lazio, T. Joseph W.; Luo, Rui; Mahony, Elizabeth K.; Ryder, Stuart D.; Sadler, Elaine M.; Shannon, Ryan M.; Han, Jinlin; Lee, Kejia; Zhang, Bing "Characterizing the Fast Radio Burst Host Galaxy Population and its Connection to Transients in the Local and Extragalactic Universe," *The Astronomical Journal*, 163: 69, 2022.
- Bhat, Bratati; Gorai, Prasanta; Mondal, Suman Kumar; Chakrabarti, Sandip K.; Das, Ankan "Radiative transfer modeling of the observed line profiles in G31.41+0.31," *Advances in Space Research*, 69: 415, 2022.
- Bhukta, Netaji; Mondal, Sushanta K.; Pal, Sabyasachi "Tailed radio galaxies from the TIFR GMRT sky survey," *Monthly Notices of the Royal Astronomical Society*, 516: 372, 2022.
- Bian, S. B.; Xu, Y.; Li, J. J.; Wu, Y. W.; Zhang, B.; Chen, X.; Li, Y. J.; Lin, Z. H.; Hao, C. J.; Liu, D. J. "Parallax of Star-forming Region G027.22+0.14," *The Astronomical Journal*, 163: 54, 2022.
- Bianchi, Eleonora; López-Sepulcre, Ana; Ceccarelli, Cecilia; Codella, Claudio; Podio, Linda; Bouvier, Mathilde; Enrique-Romero, Joan "The Two Hot Corinos of the SVS13-A Protostellar Binary System: Counterposed Siblings," *The Astrophysical Journal*, 928: L3, 2022.
- Bianchi, Simone; Casasola, Viviana; Corbelli, Edvige; Galliano, Frédéric; Magrini, Laura; Nersesian, Angelos; Salvestrini, Francesco; Baes, Maarten; Cassarà, Letizia P.; Clark, Christopher J. R.; De Looze, Ilse; Jones, Anthony P.; Madden, Suzanne C.; Mosenkov, Aleksandr; Ysard, Nathalie "Dust emissivity in resolved spiral galaxies," *Astronomy and Astrophysics*, 664: A187, 2022.
- Bilous, A. V.; GrieBmeier, J. M.; Pennucci, T.; Wu, Z.; Bondonneau, L.; Kondratiev, V.; Van Leeuwen, J.; Maan, Y.; Connor, L.; Oostrum, L. C.; Petroff, E.; Verbiest, J. P. W.; Vohl, D.; Mckee, J. W.; Shaifullah, G.; Theureau, G.; Ulyanov, O. M.; Ceccconi, B.; Coolen, A. H.; Corbel, S.; Damstra, S.; Dénes, H.; Girard, J. N.; Hut, B.; Ivashina, M.; Konovalenko, O. O.; Kutkin, A.; Loose, G. M.; Mulder, H.; Ruiter, M.; Smits, R.; Tokarsky, P. L.; Vermaas, N. J.; Zakharenko, V. V.; Zarka, P.; Ziemke, J. "Dual-frequency single-pulse study of PSR B0950+08," *Astronomy and Astrophysics*, 658: A143, 2022.
- Bobylev, V. V.; Bajkova, A. T. "Parameters of the Galactic Spiral Density Wave from Masers with Parallax Errors Less Than 10%," *Astronomy Letters*, 48: 376, 2022.
- Bobylev, V. V.; Bajkova, A. T.; Mishurov, Yu. N. "Parameters of the Radcliffe Wave from Masers, Radio Stars, and T Tauri Stars," *Astronomy Letters*, 48: 434, 2022.
- Boettcher, Erin; Gupta, Neeraj; Chen, Hsiao-Wen; Chen, Mandy C.; Józsa, Gyula I. G.; Rudie, Gwen C.; Cantalupo, Sebastiano; Johnson, Sean D.; Balashev, S. A.; Combes, Françoise; Cooksey, Kathy L.; Faucher-Giguère, Claude-André; Krogager, Jens-Kristian; Lopez, Sebastian; Momjian, Emmanuel; Noterdaeme, Pasquier; Petitjean, Patrick; Rafelski, Marc; Srianand, Raghunathan; Walth, Gregory L.; Zahedy, Fakhri S. "Discovery of a Damped Ly $\alpha$  Absorber Originating in a Spectacular Interacting Dwarf Galaxy Pair at  $z = 0.026$ ," *The Astrophysical Journal*, 926: L33, 2022.
- Bógnér, R.; Csengeri, T.; Montillaud, J.; Wienen, M.; Schneider, N.; Wyrowski, F.; Motte, F.; Tóth, L. V. "Ammonia characterisation of dense cores in the Rosette Molecular Cloud," *Astronomy and Astrophysics*, 667: A137, 2022.
- Bohn, A. J.; Benisty, M.; Perraut, K.; Van Der Marel, N.; Wölfer, L.; Van Dishoeck, E. F.; Facchini, S.; Manara, C. F.; Teague, R.; Francis, L.; Berger, J.-P.; García-Lopez, R.; Ginski, C.; Henning, T.; Kenworthy, M.; Kraus, S.; Ménard, F.; Mérand, A.; Pérez, L. M. "Probing inner and outer disk misalignments in transition disks. Constraints from VLT/GRAVITY and ALMA observations," *Astronomy and Astrophysics*, 658: A183, 2022.
- Bonnassieux, Etienne; Sweijen, Frits; Brienza, Marisa; Rajpurohit, Kamlesh; John Riseley, Christopher; Bonafede, Annalisa; Jackson, Neal; Morabito, Leah K.; Brunetti, Gianfranco; Harwood, Jeremy; Kappes, Alex; Rottgering, Huub J.; Tasse, Cyril; Van Weeren, Reinout "Spectral analysis of spatially resolved 3C295 (sub-arcsecond resolution) with the International LOFAR Telescope," *Astronomy and Astrophysics*, 658: A10, 2022.
- Booth, Rebecca A.; Kothes, Roland; Landecker, Tom; Brown, Jo-Anne; Gray, Andrew; Foster, Tyler; Greisen, Eric "A New Distance to the Supernova Remnant DA 530 Based on H I Absorption of Polarized Emission," *The Astrophysical Journal*, 941: 17, 2022.
- Bordiu, C.; Rizzo, J. R.; Bufano, F.; Quintana-Lacaci, G.; Buemi, C.; Leto, P.; Cavallaro, F.; Cerrigone, L.; Ingallinera, A.; Loru, S.; Riggi, S.; Trigilio, C.; Umana, G.; Sciacca, E. "First Detection of Silicon-bearing Molecules in  $\eta$  Car," *The Astrophysical Journal*, 939: L30, 2022.
- Boselli, A.; Fossati, M.; Longobardi, A.; Kianfar, K.; Dametto, N. Z.; Amram, P.; Anderson, J. P.; Andreani, P.; Boissier, S.; Boquien, M.; Buat, V.; Consolandi, G.; Cortese, L.; Côté, P.; Cuillandre, J. C.; Ferrarese, L.; Galbany, L.; Gavazzi, G.; Gwyn, S.; Hensler, G.; Hutchings, J.; Peng, E. W.; Postma, J.; Roediger, J.; Roehly, Y.; Serra, P.; Trinchieri, G. "A Virgo Environmental Survey Tracing Ionised Gas Emission (VESTIGE). XII. Ionised gas emission in the inner regions of lenticular galaxies," *Astronomy and Astrophysics*, 659: A46, 2022.
- Bouwens, R. J.; Smit, R.; Schouws, S.; Stefanon, M.; Bowler, R.; Endsley, R.; Gonzalez, V.; Inami, H.; Stark, D.; Oesch, P.; Hodge, J.; Aravena, M.; Da Cunha, E.; Dayal, P.; Looze, I. De; Ferrara, A.; Fudamoto, Y.; Graziani, L.; Li, C.; Nanayakkara, T.; Pallottini, A.; Schneider, R.; Sommovigo, L.; Topping, M.; Van Der Werf, P.; Algera, H.; Barrufet, L.; Hygate, A.; Labbé, I.; Riechers, D.; Witstok, J. "Reionization Era Bright Emission Line Survey: Selection and Characterization of Luminous Interstellar Medium Reservoirs in the  $z > 6.5$  Universe," *The Astrophysical Journal*, 931: 160, 2022.
- Bowler, R. A. A.; Cullen, F.; Mclure, R. J.; Dunlop, J. S.; Avison, A. "The discovery of rest-frame UV colour gradients and a diversity of dust morphologies in bright  $z \sim 7$  Lyman-break galaxies," *Monthly Notices of the Royal Astronomical Society*, 510: 5088, 2022.
- Boyce, H.; Haggard, D.; Witzel, G.; Fellenberg, S. Von; Willner, S. P.; Becklin, E. E.; Do, T.; Eckart, A.; Fazio, G. G.; Gurwell, M. A.; Hora, J. L.; Markoff, S.; Morris, M. R.; Neilsen, J.; Nowak, M.; Smith, H. A.; Zhang, S. "Multiwavelength Variability of Sagittarius A\* in 2019 July," *The Astrophysical Journal*, 931: 7, 2022.
- Bramson, A. M.; Carter, L. M.; Patterson, G. W.; Sori, M. M.; Morgan, G. A.; Jozwiak, L. M.; Nypaver, C. A.; Cahill, J. T. S. "Burial Depths of Extensive Shallow Cryptomaria in the Lunar Schiller-Schickard Region," *The Planetary Science Journal*, 3: 216, 2022.
- Breyse, Patrick C.; Yang, Shengqi; Somerville, Rachel S.; Pullen, Anthony R.; Popping, Gergő; Maniyar, Abhishek S. "On Estimating the Cosmic Molecular Gas Density from CO Line Intensity Mapping Observations," *The Astrophysical Journal*, 929: 30, 2022.
- Bright, Joe S.; Margutti, Raffaella; Matthews, David; Brethauer, Daniel; Coppejans, Deanne; Wieringa, Mark H.; Metzger, Brian D.; Demarchi, Lindsay; Laskar, Tanmoy; Romero, Charles; Alexander, Kate D.; Horesh, Assaf; Migliori, Giulia; Chornock, Ryan; Berger, E.; Bietenholz, Michael; Devlin, Mark J.; Dicker, Simon R.; Jacobson-Galán, W. V.; Mason, Brian S.; Milisavljevic, Dan; Motta, Sara E.; Mroczkowski, Tony; Ramirez-Ruiz, Enrico; Rhodes, Lauren; Sarazin, Craig L.; Sfaradi, Itai; Sievers, Jonathan "Radio and X-Ray Observations of the Luminous Fast Blue Optical Transient AT 2020xnd," *The Astrophysical Journal*, 926: 112, 2022.
- Broderick, Avery E.; Gold, Roman; Georgiev, Boris; Pesce, Dominic W.; Tiede, Paul; Ni, Chunhong; Moriyama, Kotaro; Akiyama, Kazunori; Alberdi, Antxon; Alef, Walter; Algaba, Juan Carlos; Anantua, Richard; Asada, Keiichi; Azulay, Rebecca; Bach, Uwe; Baczko, Anne-Kathrin; Ball, David; Baloković, Mislav; Barrett, John; Bauböck, Michi; Benson, Bradford A.; Bintley, Dan; Blackburn, Lindy; Blundell, Raymond; Bouman, Katherine L.; Bower, Geoffrey C.; Boyce, Hope; Bremer, Michael; Brinkerink, Christiaan D.; Brissenden, Roger; Britzen, Silke; Brogiere, Dominique; Bronzwaer, Thomas; Bustamante, Sandra; Byun, Do-Young; Carlstrom, John E.; Ceccobello, Chiara; Chael, Andrew; Chan, Chi-Kwan; Chatterjee, Koushik; Chatterjee, Shami; Chen, Ming-Tang; Chen, Yongjun; Cheng, Xiaopeng; Cho, Ilje; Christian, Pierre; Conroy, Nicholas

## APPENDIX A: PUBLICATIONS

- S.; Conway, John E.; Cordes, James M.; Crawford, Thomas M.; Crew, Geoffrey B.; Cruz-Orsorio, Alejandro; Cui, Yuzhu; Davelaar, Jordy; De Laurentis, Mariafelicia; Deane, Roger; Dempsey, Jessica; Desvignes, Gregory; Dexter, Jason; Dhruv, Vedant; Doleman, Sheperd S.; Dougal, Sean; Dzib, Sergio A.; Eatough, Ralph P.; Emami, Razieh; Falcke, Heino; Farah, Joseph; Fish, Vincent L.; Fomalont, Ed; Ford, H. Alyson; Fraga-Encinas, Raquel; Freeman, William T.; Friberg, Per; Fromm, Christian M.; Fuentes, Antonio; Galison, Peter; Gammie, Charles F.; García, Roberto; Gentaz, Olivier; Goddi, Ciriaco; Gómez-Ruiz, Arturo I.; Gómez, José L.; Gu, Minfeng; Gurwell, Mark; Hada, Kazuhiro; Haggard, Daryl; Haworth, Kari; Hecht, Michael H.; Hesper, Ronald; Heumann, Dirk; Ho, Luis C.; Ho, Paul; Honma, Mareki; Huang, Chih-Wei L.; Huang, Lei; Hughes, David H.; Ikeda, Shiro; Impellizzeri, C. M. Violette; Inoue, Makoto; Issaoun, Sara; James, David J.; Jannuzi, Buell T.; Janssen, Michael; Jeter, Britton; Jiang, Wu; Jiménez-Rosales, Alejandra; Johnson, Michael D.; Jorstad, Svetlana; Joshi, Abhishek V.; Jung, Taehyun; Karami, Mansour; Karuppusamy, Ramesh; Kawashima, Tomohisa; Keating, Garrett K.; Kettenis, Mark; Kim, Dong-Jin; Kim, Jae-Young; Kim, Jongsoo; Kim, Junhan; Kino, Motoki; Koay, Jun Yi; Kocherlakota, Prashant; Kofuji, Yutaro; Koch, Patrick M.; Koyama, Shoko; Kramer, Carsten; Kramer, Michael; Krichbaum, Thomas P.; Kuo, Cheng-Yu; Bella, Noemi La; Lauer, Tod R.; Lee, Daeyoung; Lee, Sang-Sung; Leung, Po Kin; Levis, Aviad; Li, Zhiyuan; Lico, Rocco; Lindahl, Greg; Lindqvist, Michael; Lisakov, Mikhail; Liu, Jun; Liu, Kuo; Liuzzo, Elisabetta; Lo, Wen-Ping; Lobanov, Andrei P.; Loinard, Laurent; Lonsdale, Colin J.; Lu, Ru-Sen; Mao, Jirong; Marchili, Nicola; Markoff, Sera; Marrone, Daniel P.; Marscher, Alan P.; Martí-Vidal, Iván; Matsushita, Satoki; Matthews, Lynn D.; Menten, Karl M.; Michalik, Daniel; Mizuno, Izumi; Mizuno, Yosuke; Moran, James M.; Moscibrodzka, Monika; Müller, Cornelia; Mus, Alejandro; Musoke, Gibwa; Myserlis, Ioannis; Nadolski, Andrew; Nagai, Hiroshi; Nagar, Neil M.; Nakamura, Masanori; Narayan, Ramesh; Narayanan, Gopal; Natarajan, Inyuan; Nathanael, Antonios; Fuentes, Santiago Navarro; Neilsen, Jørg; Neri, Roberto; Noutsos, Aristeidis; Nowak, Michael A.; Oh, Junghwan; Okino, Hiroki; Olivares, Héctor; Ortiz-León, Gisela N.; Oyama, Tomoaki; Palumbo, Daniel C. M.; Paraschos, Georgios Filippos; Park, Jongho; Parsons, Harriet; Patel, Nimesh; Pen, Ue-Li; Piétu, Vincent; Plambeck, Richard; Popstefanija, Aleksandar; Porth, Oliver; Pözl, Felix M.; Prather, Ben; Preciado-López, Jorge A.; Pu, Hung-Yi; Ramakrishnan, Venkatesh; Rao, Ramprasad; Rawlings, Mark G.; Raymond, Alexander W.; Rezzolla, Luciano; Ricarte, Angelo; Ripperda, Bart; Roelofs, Freek; Rogers, Alan; Ros, Eduardo; Romero-Cañizales, Cristina; Roshanineshat, Arash; Rottmann, Helge; Roy, Alan L.; Ruiz, Ignacio; Ruszczyk, Chet; Rygl, Kazi L. J.; Sánchez, Salvador; Sánchez-Argüelles, David; Sánchez-Portal, Miguel; Sasada, Mahito; Satapathy, Kaushik; Savolainen, Tuomas; Schloerb, F. Peter; Schonfeld, Jonathan; Schuster, Karl-Friedrich; Shao, Lijing; Shen, Zhiqiang; Small, Des; Sohn, Bong Won; Soohoo, Jason; Souccar, Kamal; Sun, He; Tazaki, Fumie; Tetarenko, Alexandra J.; Tilanus, Remo P. J.; Titus, Michael; Torne, Pablo; Traianou, Efthalia; Trent, Tyler; Trippe, Sascha; Turk, Matthew; Van Bemmelen, Ilse; Van Langevelde, Huib Jan; Van Rossum, Daniel R.; Vos, Jesse; Wagner, Jan; Ward-Thompson, Derek; Wardle, John; Weintraub, Jonathan; Wex, Norbert; Wharton, Robert; Wielgus, Maciek; Wiik, Kaj; Witzel, Gunther; Wondrak, Michael F.; Wong, George N.; Wu, Qingwen; Yamaguchi, Paul; Yoon, Doosoo; Young, André; Young, Ken; Younsi, Ziri; Yuan, Feng; Yuan, Ye-Fei; Zensus, J. Anton; Zhao, Guang-Yao; Zhang, Shuo; Zhao, Shan-Shan "Characterizing and Mitigating Intraday Variability: Reconstructing Source Structure in Accreting Black Holes with mm-VLBI," *The Astrophysical Journal*, 930: L21, 2022.
- Broderick, J. W.; Drouart, G.; Seymour, N.; Galvin, T. J.; Wright, N.; Carnero Rosell, A.; Chhetri, R.; Dannenberg, H.; Driver, S. P.; Morgan, J. S.; Moss, V. A.; Prabu, S.; Afonso, J. M.; De Breuck, C.; Emonts, B. H. C.; Franzen, T. M. O.; Gutiérrez, C. M.; Hancock, P. J.; Heald, G. H.; Hurlley-Walker, N.; Ivison, R. J.; Lehnert, M. D.; Noirot, G.; Read, M.; Shabala, S. S.; Stern, D.; Sutherland, W. J.; Sutorius, E.; Turner, R. J.; Vernet, J. "The GLEAMing of the first supermassive black holes: II. A new sample of high-redshift radio galaxy candidates," *Publications of the Astronomical Society of Australia*, 39: e061, 2022.
- Brouillet, N.; Despois, D.; Molet, J.; Nony, T.; Motte, F.; Gusdorf, A.; Louvet, F.; Bontemps, S.; Herpin, F.; Bonfand, M.; Csengeri, T.; Ginsburg, A.; Cunningham, N.; Galván-Madrid, R.; Maud, L.; Busquet, G.; Bronfman, L.; Fernández-López, M.; Jeff, D. L.; Lefloch, B.; Pouteau, Y.; Sanhueza, P.; Stutz, A. M.; Vaille-Manet, M. "ALMA-IMF. IV. A comparative study of the main hot cores in W43-MM1: Detection, temperature, and molecular composition," *Astronomy and Astrophysics*, 665: A140, 2022.
- Brunetti, Nathan; Wilson, Christine D. "Extreme giant molecular clouds in the luminous infrared galaxy NGC 3256," *Monthly Notices of the Royal Astronomical Society*, 515: 2928, 2022.
- Bruni, G.; Bassani, L.; Persic, M.; Rephaeli, Y.; Malizia, A.; Molina, M.; Focchi, M.; Ricci, R.; Wieringa, M. H.; Giroletti, M.; Panessa, F.; Bazzano, A.; Ubertini, P. "IGR J18249-3243: a new GeV-emitting FR II and the emerging population of high-energy radio galaxies," *Monthly Notices of the Royal Astronomical Society*, 513: 886, 2022.
- Brunken, Nashant G. C.; Booth, Alice S.; Leemker, Margot; Nazari, Pooneh; Van Der Marel, Nienke; Van Dishoeck, Ewine F. "A major asymmetric ice trap in a planet-forming disk. III. First detection of dimethyl ether," *Astronomy and Astrophysics*, 659: A29, 2022.
- Bublitz, J.; Kastner, J. H.; Hily-Blant, P.; Forveille, T.; Santander-García, M.; Alcolea, J.; Bujarrabal, V. "Sampling molecular gas in the Helix planetary nebula: Variation in HNC/HCN with UV flux," *Astronomy and Astrophysics*, 659: A197, 2022.
- Burd, P. R.; Kadler, M.; Mannheim, K.; Baczko, A.-K.; Ringholz, J.; Ros, E. "Dual-high-frequency VLBI study of blazar-jet brightness-temperature gradients and collimation profiles," *Astronomy and Astrophysics*, 660: A1, 2022.
- Burgarella, D.; Bogdanoska, J.; Nanni, A.; Bardelli, S.; Béthermin, M.; Boquien, M.; Buat, V.; Faisst, A. L.; Dessauges-Zavadsky, M.; Fudamoto, Y.; Fujimoto, S.; Gialavisco, M.; Ginolfi, M.; Gruppioni, C.; Hathi, N. P.; Ibar, E.; Jones, G. C.; Koekemoer, A. M.; Kohno, K.; Lemaux, B. C.; Narayanan, D.; Oesch, P.; Ouchi, M.; Riechers, D. A.; Pozzi, F.; Romano, M.; Schaerer, D.; Talia, M.; Theulé, P.; Vergani, D.; Zamorani, G.; Zucca, E.; Cassata, P.; Alpine Team "The ALMA-ALPINE [CII] survey. The star formation history and the dust emission of star-forming galaxies at  $4.5 < z < 6.2$ ," *Astronomy and Astrophysics*, 664: A73, 2022.
- Burgess, Daniel A.; Mori, Kaya; Gelfand, Joseph D.; Hailey, Charles J.; Tokayer, Yarone M.; Woo, Jooyun; An, Hongjun; Malone, Kelly; Reynolds, Stephen P.; Safi-Harb, Samar; Temim, Tea "The Eel Pulsar Wind Nebula: A PeVatron-candidate Origin for HAWC J1826-128 and HESS J1826-130," *The Astrophysical Journal*, 930: 148, 2022.
- Burton, Kiana; Macgregor, Meredith A.; Osten, Rachel A. "First Millimeter Flares Detected from Eridani with the Atacama Large Millimeter/submillimeter Array," *The Astrophysical Journal*, 939: L6, 2022.
- Busch, Laura A.; Belloche, Arnaud; Garrod, Robin T.; Müller, Holger S. P.; Menten, Karl M. "Resolving desorption of complex organic molecules in a hot core. Transition from non-thermal to thermal desorption or two-step thermal desorption?," *Astronomy and Astrophysics*, 665: A96, 2022.
- Butterfield, Natalie O.; Lang, Cornelia C.; Ginsburg, Adam; Morris, Mark R.; Ott, Jürgen; Ludovici, Dominic A. "Evidence for an Interaction between the Galactic Center Clouds M0.10-0.08 and M0.11-0.11," *The Astrophysical Journal*, 936: 186, 2022.
- Cala, Roldán A.; Gómez, José F.; Miranda, Luis F.; Uscanga, Lucero; Breen, Shari L.; Dawson, Joanne R.; De Gregorio-Monsalvo, Itziar; Imai, Hiroshi; Qiao, Hai-Hua; Suárez, Olga "Searching for nascent planetary nebulae: OHPNe candidates in the SPLASH survey," *Monthly Notices of the Royal Astronomical Society*, 516: 2235, 2022.
- Cambioni, Saverio; De Kleer, Katherine; Shepard, Michael "The Heterogeneous Surface of Asteroid (16) Psyche," *Journal of Geophysical Research (Planets)*, 127: e07091, 2022.
- Campbell, Bruce A.; Campbell, Donald B. "Arecibo Radar Maps of Venus from 1988 to 2020," *The Planetary Science Journal*, 3: 55, 2022.

- Cao, Hong-Min; Migliori, Giulia; Giroletti, Marcello; Frey, Sándor; Yang, Jun; Gabányi, Krisztina É.; Cui, Lang; An, Tao; Hong, Xiao-Yu; Zhang, Wen-Da "A long-lived compact jet in the black hole X-ray binary candidate AT2019wey," *Astronomy and Astrophysics*, 657: A104, 2022.
- Carilli, Chris L.; Thyagarajan, Nithyanandan "Hybrid Mapping of the Black Hole Shadow in M87," *The Astrophysical Journal*, 924: 125, 2022.
- Carilli, Christopher L.; Anderson, Craig S.; Tozzi, Paolo; Pannella, Maurizio; Clarke, Tracy; Pentericci, L.; Liu, Ang; Mroczkowski, Tony; Miley, G. K.; Rottgering, H. J.; Borgani, S.; Norman, Colin; Saro, A.; Nonino, M.; Di Mascolo, L. "X-Ray Emission from the Jets and Lobes of the Spiderweb," *The Astrophysical Journal*, 928: 59, 2022.
- Carilli, Christopher L.; Perley, Richard A.; Perley, Daniel A.; Dhawan, Vivek; Decarli, Roberto; Evans, Aaron S.; Nyland, Kristina "A 4 kpc Molecular Gas Lane in Cygnus A," *The Astrophysical Journal*, 937: 106, 2022.
- Carpenter, John M.; Corvillón, Andrea; Meyer, Jennifer Donovan; Plunkett, Adele L.; Kuroski, Robert; Chalevin, Alex; Macías, Enrique "Update on the Systematics in the ALMA Proposal Review Process After Cycle 8," *Publications of the Astronomical Society of the Pacific*, 134: 045001, 2022.
- Carretti, Ettore; Vacca, V.; O'Sullivan, S. P.; Heald, G. H.; Horellou, C.; Röttgering, H. J. A.; Scaife, A. M. M.; Shimwell, T. W.; Shulevski, A.; Stuardi, C.; Vernstrom, T. "Magnetic field strength in cosmic web filaments," *Monthly Notices of the Royal Astronomical Society*, 512: 945, 2022.
- Casa Team; Bean, Ben; Bhatnagar, Sanjay; Castro, Sandra; Donovan Meyer, Jennifer; Emonts, Bjorn; García, Enrique; Garwood, Robert; Golap, Kumar; Villalba, Justo Gonzalez; Harris, Pamela; Hayashi, Yohei; Hoskins, Josh; Hsieh, Mingyu; Jagannathan, Preshanth; Kawasaki, Wataru; Keimpema, Aard; Kettenis, Mark; Lopez, Jorge; Marvil, Joshua; Masters, Joseph; McNichols, Andrew; Mehringer, David; Miel, Renaud; Moellenbrock, George; Montesino, Federico; Nakazato, Takeshi; Ott, Juergen; Petry, Dirk; Pokorny, Martin; Raba, Ryan; Rau, Urvashi; Schiebel, Darrell; Schweighart, Neal; Sekhar, Srikrishna; Shimada, Kazuhiko; Small, Des; Steeb, Jan-Willem; Sugimoto, Kanako; Suoranta, Ville; Tsutsumi, Takahiro; Van Bemmelen, Ilse M.; Verkouter, Marjolein; Wells, Akeem; Xiong, Wei; Szomoru, Arpad; Griffith, Morgan; Glendenning, Brian; Kern, Jeff "CASA, Common Astronomy Software Applications for Radio Astronomy," *Publications of the Astronomical Society of the Pacific*, 134: 114501, 2022.
- Casasola, Viviana; Bianchi, Simone; Magrini, Laura; Mosenkov, Aleksandr V.; Salvestrini, Francesco; Baes, Maarten; Calura, Francesco; Cassarà, Letizia P.; Clark, Christopher J. R.; Corbelli, Edvige; Fritz, Jacopo; Galliano, Frédéric; Luzzo, Elisabetta; Madden, Suzanne; Nersesian, Angelos; Pozzi, Francesca; Roychowdhury, Sambit; Baronchelli, Ivano; Bonato, Matteo; Gruppioni, Carlotta; Pantoni, Lara "The resolved scaling relations in DustPedia: Zooming in on the local Universe," *Astronomy and Astrophysics*, 668: A130, 2022.
- Casassus, Simon; Cárcamo, Miguel "Variable structure in the PDS 70 disc and uncertainties in radio-interferometric image restoration," *Monthly Notices of the Royal Astronomical Society*, 513: 5790, 2022.
- Casassus, Simon; Cárcamo, Miguel; Hales, Antonio; Weber, Philipp; Dent, Bill "The Doppler Flip in HD 100546 as a Disk Eruption: The Elephant in the Room of Kinematic Protoplanet Searches," *The Astrophysical Journal*, 933: L4, 2022.
- Caselli, Paola; Pineda, Jaime E.; Sipilä, Olli; Zhao, Bo; Redaelli, Elena; Spezzano, Silvia; Maureira, Maria José; Alves, Felipe; Bizzocchi, Luca; Bourke, Tyler L.; Chacón-Tanarro, Ana; Friesen, Rachel; Galli, Daniele; Harju, Jorma; Jiménez-Serra, Izaskun; Keto, Eric; Li, Zhi-Yun; Padovani, Marco; Schmiedeke, Anika; Tafalla, Mario; Vastel, Charlotte "The Central 1000 au of a Prestellar Core Revealed with ALMA. II. Almost Complete Freeze-out," *The Astrophysical Journal*, 929: 13, 2022.
- Cendes, Y.; Berger, E.; Alexander, K. D.; Gomez, S.; Hajela, A.; Chornock, R.; Laskar, T.; Margutti, R.; Metzger, B.; Bietenholz, M. F.; Brethauer, D.; Wieringa, M. H. "A Mildly Relativistic Outflow Launched Two Years after Disruption in Tidal Disruption Event AT2018hyz," *The Astrophysical Journal*, 938: 28, 2022.
- Cendes, Y.; Williams, P. K. G.; Berger, E. "A Pilot Radio Search for Magnetic Activity in Directly Imaged Exoplanets," *The Astronomical Journal*, 163: 15, 2022.
- Chahine, L.; López-Sepulcre, A.; Neri, R.; Ceccarelli, C.; Mercimek, S.; Codella, C.; Bouvier, M.; Bianchi, E.; Favre, C.; Podio, L.; Alves, F. O.; Sakai, N.; Yamamoto, S. "Organic chemistry in the protosolar analogue HOPS-108: Environment matters," *Astronomy and Astrophysics*, 657: A78, 2022.
- Chahine, L.; López-Sepulcre, A.; Podio, L.; Codella, C.; Neri, R.; Mercimek, S.; De Simone, M.; Caselli, P.; Ceccarelli, C.; Bouvier, M.; Sakai, N.; Fontani, F.; Yamamoto, S.; Alves, F. O.; Lattanzi, V.; Evans, L.; Favre, C. "OMC-2 FIR 4 under the microscope: Shocks, filaments, and a highly collimated jet at 100 au scales," *Astronomy and Astrophysics*, 667: A6, 2022.
- Chai, Yi; Gary, Dale E.; Reardon, Kevin P.; Yurchyshyn, Vasyl "A Study of Sunspot 3 Minute Oscillations Using ALMA and GST," *The Astrophysical Journal*, 924: 100, 2022.
- Chakraborty, Avinanda; Bhattacharjee, Anirban; Brotherton, Michael S.; Chatterjee, Ritaban; Chatterjee, Suchetana; Gilbert, Miranda "Radio dichotomy in quasars with H  $\beta$  FWHM greater than 15 000 km s<sup>-1</sup>," *Monthly Notices of the Royal Astronomical Society*, 516: 2824, 2022.
- Chandra, Poonam; Chevalier, Roger A.; James, Nicholas J. H.; Fox, Ori D. "The luminous type IIn supernova SN 2017hcc: Infrared bright, X-ray and radio faint," *Monthly Notices of the Royal Astronomical Society*, 517: 4151, 2022.
- Charles, N.; Bernardi, G.; Bester, H. L.; Smirnov, O. M.; Carilli, C.; Keller, P. M.; Kern, N.; Nikolic, B.; Thyagarajan, N.; Acedo, E. De Lera; Fagnoni, N.; Santos, M. G. "Simulations of primary beam effects on the cosmic bispectrum phase observed with the hydrogen epoch of reionization array," *Monthly Notices of the Royal Astronomical Society*, 512: 2716, 2022.
- Chatterjee, Swarna; Rahaman, Majidul; Datta, Abhirup; Raja, Ramij "Unveiling the Origin of Peculiar Diffuse Radio Emission in A1351," *The Astronomical Journal*, 164: 83, 2022.
- Chawla, P.; Kaspi, V. M.; Ransom, S. M.; Bhardwaj, M.; Boyle, P. J.; Breitman, D.; Cassanelli, T.; Cubranic, D.; Dong, F. Q.; Fonseca, E.; Gaensler, B. M.; Giri, U.; Joseph, A.; Kaczmarek, J. F.; Leung, C.; Masui, K. W.; Mena-Parra, J.; Merryfield, M.; Michilli, D.; Münchmeyer, M.; Ng, C.; Patel, C.; Pearman, A. B.; Petroff, E.; Pleunis, Z.; Rahman, M.; Sanghavi, P.; Shin, K.; Smith, K. M.; Stairs, I.; Tendulkar, S. P. "Modeling Fast Radio Burst Dispersion and Scattering Properties in the First CHIME/FRB Catalog," *The Astrophysical Journal*, 927: 35, 2022.
- Chen, Chian-Chou; Liao, Cheng-Lin; Smail, Ian; Swinbank, A. M.; Ao, Y.; Bunker, A. J.; Chapman, S. C.; Hatsukade, B.; Ivison, R. J.; Lee, Minju M.; Serjeant, Stephen; Umehata, Hideki; Wang, Wei-Hao; Zhao, Y. "An ALMA Spectroscopic Survey of the Brightest Submillimeter Galaxies in the SCUBA-2-COSMOS Field (AS2COSPEC): Survey Description and First Results," *The Astrophysical Journal*, 929: 159, 2022.
- Chen, Michael Chun-Yuan; Di Francesco, James; Pineda, Jaime E.; Offner, Stella S. R.; Friesen, Rachel K. "Turbulence and Accretion: A High-resolution Study of the B5 Filaments," *The Astrophysical Journal*, 935: 57, 2022.
- Chen, Sina; Laor, Ari; Behar, Ehud "Quasi-simultaneous observations of radio and X-ray variability in three radio-quiet Seyfert galaxies," *Monthly Notices of the Royal Astronomical Society*, 515: 1723, 2022.
- Chen, Sina; Stevens, Jamie B.; Edwards, Philip G.; Laor, Ari; Gu, Minfeng; Berton, Marco; Järvelä, Emilia; Kharb, Preeti; Behar, Ehud; Su, Renzhi "Radio spectra of narrow-line Seyfert 1 galaxies observed with Australia Telescope Compact Array and Very Large Array Sky Survey," *Monthly Notices of the Royal Astronomical Society*, 512: 471, 2022.
- Chen, Xi; Yang, Tian; Ellingsen, Simon P.; McCarthy, Tieghe P.; Ren, Zhi-Yuan "Class I Methanol Masers Related to Shocks Induced by Bar Rotation in the Nearby Starburst Galaxy Maffei 2," *The Astrophysical Journal*, 926: 48, 2022.
- Chen, Xinkai; Wang, Jing; Kong, Xu "The Role of Inner H I Mass in Regulating

## APPENDIX A: PUBLICATIONS

- the Scatter of the Mass-Metallicity Relation," *The Astrophysical Journal*, 933: 39, 2022.
- Chen, Yu-Dong; Gao, Yu; Tan, Qing-Hua "The Dense Molecular Gas in the Luminous Infrared Galaxy NGC 1614," *Chinese Astronomy and Astrophysics*, 46: 330, 2022.
- Cheng, Cheng; Yan, Haojing; Huang, Jia-Sheng; Willmer, Christopher N. A.; Ma, Zhiyuan; Orellana-González, Gustavo "Properties of Host Galaxies of Submillimeter Sources as Revealed by JWST Early Release Observations in SMACS J0723.3-7327," *The Astrophysical Journal*, 936: L19, 2022.
- Cheng, Yu; Tan, Jonathan C.; Tobin, John J.; Fedriani, Rubén; Andersen, Morten; Wang, Junfeng "The Disk Population in a Distant Massive Protocluster," *The Astrophysical Journal*, 940: 124, 2022.
- Cheng, Yu; Tobin, John J.; Yang, Yao-Lun; Van'T Hoff, Merel L. R.; Sadavoy, Sarah I.; Osorio, Mayra; Díaz-Rodríguez, Ana Karla; Anglada, Guillem; Karnath, Nicole; Sheehan, Patrick D.; Li, Zhi-Yun; Reynolds, Nickalás; Murillo, Nadia M.; Zhang, Yichen; Megeath, S. Thomas; Tychoniec, Łukasz "Disks and Outflows in the Intermediate-mass Star-forming Region NGC 2071 IR," *The Astrophysical Journal*, 933: 178, 2022.
- Cherepashchuk, A. M.; Dodin, A. V.; Postnov, K. A.; Belinski, A. A.; Burlak, M. A.; Ikonnikova, N. P.; Irsmbabetova, T. R.; Trushkin, S. A. "Optical Monitoring of SS 433 in 2017-2021," *Astronomy Reports*, 66: 451, 2022.
- Chevance, Mélanie; Kruijssen, J. M. Diederik; Krumholz, Mark R.; Groves, Brent; Keller, Benjamin W.; Hughes, Annie; Glover, Simon C. O.; Henshaw, Jonathan D.; Herrera, Cinthya N.; Kim, Jaeyeon; Leroy, Adam K.; Pety, Jérôme; Razza, Alessandro; Rosolowsky, Erik; Schinnerer, Eva; Schrubba, Andreas; Barnes, Ashley T.; Bigiel, Frank; Blanc, Guillermo A.; Dale, Daniel A.; Emsellem, Eric; Faesi, Christopher M.; Grasha, Kathryn; Klessen, Ralf S.; Kreckel, Kathryn; Liu, Daizhong; Longmore, Steven N.; Meidt, Sharon E.; Querejeta, Miguel; Saito, Toshiki; Sun, Jiayi; Usero, Antonio "Pre-supernova feedback mechanisms drive the destruction of molecular clouds in nearby star-forming disc galaxies," *Monthly Notices of the Royal Astronomical Society*, 509: 272, 2022.
- Chime/Frb Collaboration; Andersen, Bridget C.; Bandura, Kevin; Bhardwaj, Mohit; Boyle, P. J.; Brar, Charanjot; Breitman, Daniela; Cassanelli, Tomas; Chatterjee, Shami; Chawla, Pragya; Cliche, Jean-François; Cubranic, Davor; Curtin, Alice P.; Deng, Meiling; Dobbs, Matt; Dong, Fengqiu Adam; Fonseca, Emmanuel; Gaensler, B. M.; Giri, Utkarsh; Good, Deborah C.; Hill, Alex S.; Joseph, Alexander; Kaczmarek, J. F.; Kader, Zarf; Kania, Joseph; Kaspi, Victoria M.; Leung, Calvin; Li, D. Z.; Lin, Hsiu-Hsien; Masui, Kiyoshi W.; Mckinven, Ryan; Mena-Parra, Juan; Merryfield, Marcus; Meyers, B. W.; Michilli, D.; Naidu, Arun; Newburgh, Laura; Ng, C.; Ordog, Anna; Patel, Chitrag; Pearlman, Aaron B.; Pen, Ue-Li; Petroff, Emily; Pleunis, Ziggy; Rafiei-Ravandi, Masoud; Rahman, Mubdi; Ransom, Scott; Renard, Andre; Sanghavi, Pranav; Scholz, Paul; Shaw, J. Richard; Shin, Kaitlyn; Siegel, Seth R.; Singh, Saurabh; Smith, Kendrick; Stairs, Ingrid; Tan, Chia Min; Tendulkar, Shriharsh P.; Vanderlinde, Keith; Wiebe, D. V.; Wulf, Dallas; Zwaniga, Andrew "Sub-second periodicity in a fast radio burst," *Nature*, 607: 256, 2022.
- Ching, Tao-Chung; Qiu, Keping; Li, Di; Ren, Zhiyuan; Lai, Shih-Ping; Berry, David; Pattle, Kate; Furuya, Ray; Ward-Thompson, Derek; Johnstone, Doug; Koch, Patrick M.; Lee, Chang Won; Hoang, Thiem; Hasegawa, Tetsuo; Kwon, Woojin; Bastien, Pierre; Eswaraiyah, Chakali; Wang, Jia-Wei; Kim, Kyoung Hee; Hwang, Jihye; Soam, Archana; Lyo, A. -Ran; Liu, Junhao; Le Gouellec, Valentin J. M.; Arzoumanian, Doris; Whitworth, Anthony; Di Francesco, James; Poidevin, Frédéric; Liu, Tie; Coudé, Simon; Tahani, Mehrnoosh; Liu, Hong-Li; Onaka, Takashi; Li, Dalei; Tamura, Motohide; Chen, Zhiwei; Tang, Xindi; Kirchschrager, Florian; Bourke, Tyler L.; Byun, Do-Young; Chen, Mike; Chen, Huei-Ru Vivien; Chen, Wen Ping; Cho, Jungyeon; Choi, Yunhee; Choi, Youngwoo; Choi, Minho; Chrysostomou, Antonio; Chung, Eun Jung; Dai, Y. Sophia; Diep, Pham Ngoc; Doi, Yasuo; Duan, Yan; Duan, Hao-Yuan; Eden, David; Fanciullo, Lapo; Fiege, Jason; Fissel, Laura M.; Franzmann, Erica; Friberg, Per; Friesen, Rachel; Fuller, Gary; Gledhill, Tim; Graves, Sarah; Greaves, Jane; Griffin, Matt; Gu, Qilao; Han, Ilseung; Hayashi, Saeko; Houde, Martin; Hull, Charles L. H.; Inoue, Tsuyoshi; Inutsuka, Shu-Ichiro; Iwasaki, Kazunari; Jeong, Il-Gyo; Könyves, Vera; Kang, Ji-Hyun; Kang, Miju; Karoly, Janik; Kataoka, Akimasa; Kawabata, Koji; Kemper, Francisca; Kim, Jongsoo; Kim, Mi-Ryang; Kim, Shinyoung; Kim, Hyosung; Kim, Kee-Tae; Kim, Gwanjeong; Kirk, Jason; Kobayashi, Masato I. N.; Kusune, Takayoshi; Kwon, Jungmi; Lacaille, Kevin; Law, Chi-Yan; Lee, Sang-Sung; Lee, Hyeseung; Lee, Jeong-Eun; Lee, Chin-Fei; Lee, Yong-Hee; Li, Guangxing; Li, Hua-Bai; Lin, Sheng-Jun; Liu, Sheng-Yuan; Lu, Xing; Mairs, Steve; Matsumura, Masafumi; Matthews, Brenda; Moriarty-Schieven, Gerald; Nagata, Tetsuya; Nakamura, Fumitaka; Nakanishi, Hiroyuki; Ngoc, Nguyen Bich; Ohashi, Nagayoshi; Park, Geumsook; Parsons, Harriet; Peretto, Nicolas; Priestley, Felix; Pyo, Tae-Soo; Qian, Lei; Rao, Ramprasad; Rawlings, Mark; Rawlings, Jonathan; Retter, Brendan; Richer, John; Rigby, Andrew; Sadavoy, Sarah; Saito, Hiro; Savini, Giorgio; Seta, Masumichi; Shimajiri, Yoshito; Shinnaga, Hiroko; Tang, Ya-Wen; Tomisaka, Kohji; Tram, Le Ngoc; Tsukamoto, Yusuke; Viti, Serena; Wang, Hongchi; Wu, Jintai; Xie, Jinjin; Yang, Meng-Zhe; Yen, Hsi-Wei; Yoo, Hyunju; Yuan, Jinghua; Yun, Hyeong-Sik; Zenko, Tetsuya; Zhang, Chuan-Peng; Zhang, Yapeng; Zhang, Guoyin; Zhou, Jianjun; Zhu, Lei; De Looze, Ilse; André, Philippe; Dowell, C. Darren; Eyres, Stewart; Falle, Sam; Robitaille, Jean-François; Van Loo, Sven "The JCMT BISTRO-2 Survey: Magnetic Fields of the Massive DR21 Filament," *The Astrophysical Journal*, 941: 122, 2022.
- Chung, Dongwoo T.; Breyse, Patrick C.; Cleary, Kieran A.; Ihle, Håvard T.; Padmanabhan, Hamsa; Silva, Marta B.; Richard Bond, J.; Borowska, Jowita; Catha, Morgan; Church, Sarah E.; Dunne, Delaney A.; Kristian Eriksen, Hans; Kristine Foss, Marie; Gaier, Todd; Ott Gundersen, Joshua; Harper, Stuart E.; Harris, Andrew I.; Hensley, Brandon; Hobbs, Richard; Keating, Laura C.; Kim, Junhan; Lamb, James W.; Lawrence, Charles R.; Gahr Sturtzel Lunde, Jonas; Murray, Norman; Pearson, Timothy J.; Philip, Liju; Rasmussen, Maren; Readhead, Anthony C. S.; Rennie, Thomas J.; Stutzer, Nils-Ole; Uzgil, Bade D.; Viero, Marco P.; Watts, Duncan J.; Wechsler, Risa H.; Kathrine Wehus, Ingunn; Woody, David P.; Comap Collaboration "COMAP Early Science. V. Constraints and Forecasts at z 3," *The Astrophysical Journal*, 933: 186, 2022.
- Cleary, Kieran A.; Borowska, Jowita; Breyse, Patrick C.; Catha, Morgan; Chung, Dongwoo T.; Church, Sarah E.; Dickinson, Clive; Eriksen, Hans Kristian; Foss, Marie Kristine; Gundersen, Joshua Ott; Harper, Stuart E.; Harris, Andrew I.; Hobbs, Richard; Ihle, Håvard T.; Kim, Junhan; Kocz, Jonathon; Lamb, James W.; Lunde, Jonas G. S.; Padmanabhan, Hamsa; Pearson, Timothy J.; Philip, Liju; Powell, Travis W.; Rasmussen, Maren; Readhead, Anthony C. S.; Rennie, Thomas J.; Silva, Marta B.; Stutzer, Nils-Ole; Uzgil, Bade D.; Watts, Duncan J.; Wehus, Ingunn Kathrine; Woody, David P.; Basoalto, Lilian; Bond, J. Richard; Dunne, Delaney A.; Gaier, Todd; Hensley, Brandon; Keating, Laura C.; Lawrence, Charles R.; Murray, Norman; Paladini, Roberta; Reeves, Rodrigo; Viero, Marco P.; Wechsler, Risa H.; Comap Collaboration "COMAP Early Science. I. Overview," *The Astrophysical Journal*, 933: 182, 2022.
- Clemens, Dan P.; Pillai, Thushara G. S.; Rilinger, Anneliese M.; Esparillat, Catherine C. "Near-infrared Polarization from Unresolved Disks around Brown Dwarfs and Young Stellar Objects," *The Astrophysical Journal*, 926: 67, 2022.
- Climent, J. B.; Guirado, J. C.; Zapatero Osorio, M. R.; Zakhochay, O. V.; Pérez-Torres, M.; Azulay, R.; Gauza, B.; Reboló, R.; Béjar, V. J. S.; Martín-Pintado, J.; Lefèvre, C. "Radio emission in a nearby, ultra-cool dwarf binary: A multifrequency study," *Astronomy and Astrophysics*, 660: A65, 2022.
- Codella, C.; López-Sepulcre, A.; Ohashi, S.; Chandler, C. J.; De Simone, M.; Podio, L.; Ceccarelli, C.; Sakai, N.; Alves, F.; Durán, A.; Fedele, D.; Loinard, L.; Mercimek, S.; Murillo, N.; Zhang, Y.; Bianchi, E.; Bouvier, M.; Busquet, G.; Caselli, P.; Dulieu, F.; Feng, S.; Hanawa, T.; Johnstone, D.; Lefloch, B.; Maud, L. T.; Moellenbrock, G.; Oya, Y.; Svoboda, B.; Yamamoto, S. "FAUST VI. VLA1623-2417 B: a new laboratory for astrochemistry around protostars on 50 au scale," *Monthly Notices of the Royal Astronomical Society*, 515: 543, 2022.

- Cooke, Lauren H.; Levy, Rebecca C.; Bolatto, Alberto D.; Simon, Joshua D.; Newman, Andrew B.; Teuben, Peter; Davey, Brandon D.; Wright, Melvyn; Tarantino, Elizabeth; Lenkić, Laura; Villanueva, Vicente "Cuspy dark matter density profiles in massive dwarf galaxies," *Monthly Notices of the Royal Astronomical Society*, 512: 1012, 2022.
- Cooper, Olivia R.; Casey, Caitlin M.; Zavala, Jorge A.; Champagne, Jaclyn B.; Da Cunha, Elisabete; Long, Arianna S.; Spilker, Justin S.; Staguhn, Johannes "Searching Far and Long. I. Pilot ALMA 2 mm Follow-up of Bright Dusty Galaxies as a Redshift Filter," *The Astrophysical Journal*, 930: 32, 2022.
- Cortes-Suárez, Edgar; Negrete, C. A.; Hernández-Toledo, H. M.; Ibarra-Medel, H.; Lacerda, I. "SDSS-IV MaNGA: Identification and multiwavelength properties of Type-1 AGN in the DR15 sample," *Monthly Notices of the Royal Astronomical Society*, 514: 3626, 2022.
- Costa Silva, A. R.; Fedriani, R.; Tan, J. C.; Caratti O Garatti, A.; Ramsay, S.; Rosero, V.; Cosentino, G.; Gorai, P.; Leurini, S. "NIR jets from a clustered region of massive star formation. Morphology and composition in the IRAS 18264-1152 region," *Astronomy and Astrophysics*, 659: A23, 2022.
- Cotton, W. D.; Camilo, F.; Becker, W.; Condon, J. J.; Forbrich, J.; Heywood, I.; Hugo, B.; Legodi, S.; Mauch, T.; Predehl, P.; Slane, P.; Thompson, M. A. "The Curious Case of the "Heartworm" Nebula," *The Astrophysical Journal*, 934: 78, 2022.
- Coutens, A.; Loison, J.-C.; Boulanger, A.; Caux, E.; Müller, H. S. P.; Wakelam, V.; Manigand, S.; Jørgensen, J. K. "The ALMA-PILS survey: First tentative detection of 3-hydroxypropanal (HOCH<sub>2</sub>CHO) in the interstellar medium and chemical modeling of the C<sub>3</sub>H<sub>4</sub>O<sub>2</sub> isomers," *Astronomy and Astrophysics*, 660: L6, 2022.
- Cowie, L. L.; Barger, A. J.; Bauer, F. E.; Chen, C.-C.; Jones, L. H.; Orquera-Rojas, C.; Rosenthal, M. J.; Taylor, A. J. "A Submillimeter Survey of Faint Galaxies behind 10 Strong Lensing Clusters," *The Astrophysical Journal*, 939: 5, 2022.
- Cox, Erin G.; Novak, Giles; Sadavoy, Sarah I.; Looney, Leslie W.; Lee, Dennis; Berthoud, Marc; Bourke, Tyler L.; Coudé, Simon; Encalada, Frankie; Fissel, Laura M.; Harrison, Rachel; Houde, Martin; Li, Zhi-Yun; Myers, Philip C.; Pattle, Kate; Santos, Fabio P.; Stephens, Ian W.; Wang, Hailin; Wolf, Sebastian "The Twisted Magnetic Field of the Protobinary L483," *The Astrophysical Journal*, 932: 34, 2022.
- Cronin-Coltsmann, Patrick F.; Kennedy, Grant M.; Adam, Christian; Kral, Quentin; Lestrade, Jean-François; Marino, Sebastian; Matrà, Luca; Murphy, Simon J.; Olofsson, Johan; Wyatt, Mark C. "ALMA's view of the M-dwarf GSC 07396-00759's edge-on debris disc: AU Mic's coeval twin," *Monthly Notices of the Royal Astronomical Society*, 512: 4752, 2022.
- Curiel, Salvador; Ortiz-León, Gisela N.; Mioduszewski, Amy J.; Sanchez-Bermudez, Joel "3D Orbital Architecture of a Dwarf Binary System and Its Planetary Companion," *The Astronomical Journal*, 164: 93, 2022.
- Curone, P.; Izquierdo, A. F.; Testi, L.; Lodato, G.; Facchini, S.; Natta, A.; Pinilla, P.; Kurtovic, N. T.; Toci, C.; Benisty, M.; Tazzari, M.; Borsa, F.; Lombardi, M.; Manara, C. F.; Sanchis, E.; Ricci, L. "A giant planet shaping the disk around the very low-mass star CIDA 1," *Astronomy and Astrophysics*, 665: A25, 2022.
- Currie, Thayne; Lawson, Kellen; Schneider, Glenn; Lyra, Wladimir; Wisniewski, John; Grady, Carol; Guyon, Olivier; Tamura, Motohide; Kotani, Takayuki; Kawahara, Hajime; Brandt, Timothy; Uyama, Taichi; Muto, Takayuki; Dong, Ruobing; Kudo, Tomoyuki; Hashimoto, Jun; Fukagawa, Misato; Wagner, Kevin; Lozi, Julien; Chilcote, Jeffrey; Tobin, Taylor; Groff, Tyler; Ward-Duong, Kimberly; Januszewski, William; Norris, Barnaby; Tuthill, Peter; Van Der Marel, Nienke; Sitko, Michael; Deo, Vincent; Vievard, Sebastien; Jovanovic, Nemanja; Martinache, Frantz; Skaf, Nour "Images of embedded Jovian planet formation at a wide separation around AB Aurigae," *Nature Astronomy*, 6: 751, 2022.
- Cyganowski, C. J.; Ilee, J. D.; Brogan, C. L.; Hunter, T. R.; Zhang, S.; Harries, T. J.; Haworth, T. J. "Discovery of a 500 au Protobinary in the Massive Prestellar Core G11.92-0.61 MM2," *The Astrophysical Journal*, 931: L31, 2022.
- Da Silva Santos, J. M.; Danilovic, S.; Leenaarts, J.; De La Cruz Rodríguez, J.; Zhu, X.; White, S. M.; Vissers, G. J. M.; Rempel, M. "Heating of the solar chromosphere through current dissipation," *Astronomy and Astrophysics*, 661: A59, 2022.
- Da Silva Santos, J. M.; White, S. M.; Reardon, K.; Cauzzi, G.; Gunár, S.; Heinzel, P.; Leenaarts, J. "Subarcsecond Imaging of a Solar Active Region Filament With ALMA and IRIS," *Frontiers in Astronomy and Space Sciences*, 9: 898115, 2022.
- D'Amato, Q.; Prandoni, I.; Gilli, R.; Vignali, C.; Massardi, M.; Liuzzo, E.; Jagannathan, P.; Brienza, M.; Paladino, R.; Mignoli, M.; Marchesi, S.; Peca, A.; Chiaberge, M.; Mazzolari, G.; Norman, C. "A deep 1.4 GHz survey of the J1030 equatorial field: A new window on radio source populations across cosmic time," *Astronomy and Astrophysics*, 668: A133, 2022.
- Darling, Jeremy "The Universe is Brighter in the Direction of Our Motion: Galaxy Counts and Fluxes are Consistent with the CMB Dipole," *The Astrophysical Journal*, 931: L14, 2022.
- Das, Barnali; Chandra, Poonam; Petit, Véronique "What leads to premature upper cut-off frequencies of auroral radio emission from hot magnetic stars?," *Monthly Notices of the Royal Astronomical Society*, 515: 2008, 2022.
- Das, Barnali; Chandra, Poonam; Shultz, Matt E.; Leto, Paolo; Mikulášek, Zdeněk; Petit, Véronique; Wade, Gregg A. "Testing a scaling relation between coherent radio emission and physical parameters of hot magnetic stars," *Monthly Notices of the Royal Astronomical Society*, 517: 5756, 2022.
- Das, Barnali; Chandra, Poonam; Shultz, Matt E.; Wade, Gregg A.; Sikora, James; Kochukhov, Oleg; Neiner, Coralie; Oksala, Mary E.; Alecian, Evelyne "Discovery of Eight "Main-sequence Radio Pulse Emitters" Using the GMRT: Clues to the Onset of Coherent Radio Emission in Hot Magnetic Stars," *The Astrophysical Journal*, 925: 125, 2022.
- Dasyra, Kalliopi M.; Paraschos, Georgios F.; Bisbas, Thomas G.; Combes, Françoise; Fernández-Ontiveros, Juan Antonio "Insights into the collapse and expansion of molecular clouds in outflows from observable pressure gradients," *Nature Astronomy*, 6: 1077, 2022.
- Davis, Timothy A.; Gensior, Jindra; Bureau, Martin; Cappellari, Michele; Choi, Woosik; Elford, Jacob S.; Krujissen, J. M. Diederik; Lelli, Federico; Liang, Fu-Heng; Liu, Lijie; Ruffa, Ilaria; Saito, Toshiki; Sarzi, Marc; Schrubba, Andreas; Williams, Thomas G. "WISDOM Project - X. The morphology of the molecular ISM in galaxy centres and its dependence on galaxy structure," *Monthly Notices of the Royal Astronomical Society*, 512: 1522, 2022.
- Dayal, P.; Ferrara, A.; Sommovigo, L.; Bouwens, R.; Oesch, P. A.; Smit, R.; Gonzalez, V.; Schouws, S.; Stefanon, M.; Kobayashi, C.; Bremer, J.; Algera, H. S. B.; Aravena, M.; Bowler, R. A. A.; Da Cunha, E.; Fudamoto, Y.; Graziani, L.; Hodge, J.; Inami, H.; De Looze, I.; Palottini, A.; Riechers, D.; Schneider, R.; Stark, D.; Endsley, R. "The ALMA REBELS survey: the dust content of z 7 Lyman break galaxies," *Monthly Notices of the Royal Astronomical Society*, 512: 989, 2022.
- De Avellar, M. G. B.; Beaklini, P. P. B.; Nunes, S. P.; Moraes, P. H. R. S.; Malheiro, M. "Sudden discharge of young charged magnetars as a new model for FRBs," *Monthly Notices of the Royal Astronomical Society*, 509: 5357, 2022.
- De Breuck, C.; Lundgren, A.; Emonts, B.; Kolwa, S.; Dannerbauer, H.; Lehnert, M. "Feeding the spider with carbon. [CII] emission from the circumgalactic medium and active galactic nucleus," *Astronomy and Astrophysics*, 658: L2, 2022.
- De Gasperin, F.; Rudnick, L.; Finoguenov, A.; Wittor, D.; Akamatsu, H.; Brüggem, M.; Chibueze, J. O.; Clarke, T. E.; Cotton, W.; Cuciti, V.; Domínguez-Fernández, P.; Knowles, K.; O'Sullivan, S. P.; Sebokolodi, L. "MeerKAT view of the diffuse radio sources in Abell 3667 and their interactions with the thermal plasma," *Astronomy and Astrophysics*, 659: A146, 2022.
- De La Fuente, Eduardo; Trinidad, Miguel A.; Tafuya, Daniel; Toledano-Juárez, Ivan; García-Flores, Samuel "The symbiotic and bipolar nebula

## APPENDIX A: PUBLICATIONS

- M 2-9: Morphological variability of the collimated ionized wind arising from the core," Publications of the Astronomical Society of Japan, 74: 594, 2022.
- De Marco, Orsola; Akashi, Muhammad; Akras, Stavros; Alcolea, Javier; Aleman, Isabel; Amram, Philippe; Balick, Bruce; De Beck, Elvire; Blackman, Eric G.; Boffin, Henri M. J.; Boumis, Panos; Bublitz, Jesse; Bucciarelli, Beatrice; Bujarrabal, Valentin; Cami, Jan; Chornay, Nicholas; Chu, You-Hua; Corradi, Romano L. M.; Frank, Adam; García-Hernández, D. A.; García-Rojas, Jorge; García-Segura, Guillermo; Gómez-Llanos, Veronica; Gonçalves, Denise R.; Guerrero, Martín A.; Jones, David; Karakas, Amanda I.; Kastner, Joel H.; Kwok, Sun; Lykou, Foteini; Manchado, Arturo; Matsuura, Mikako; Mcdonald, Iain; Miszalski, Brent; Mohamed, Shazrene S.; Monreal-Ibero, Ana; Monteiro, Hektor; Montez, Rodolfo; Baez, Paula Moraga; Morisset, Christophe; Nordhaus, Jason; Mendes De Oliveira, Claudia; Osborn, Zara; Otsuka, Masaaki; Parker, Quentin A.; Peeters, Els; Quint, Bruno C.; Quintana-Lacaci, Guillermo; Redman, Matt; Rüter, Ashley J.; Sabin, Laurence; Sahai, Raghvendra; Contreras, Carmen Sánchez; Santander-García, Miguel; Seitzzahl, Ivo; Soker, Noam; Speck, Angela K.; Stanghellini, Letizia; Steffen, Wolfgang; Toalá, Jesús A.; Ueta, Toshiya; Van De Steene, Griet; Van Winckel, Hans; Ventura, Paolo; Villaver, Eva; Vlemmings, Wouter; Walsh, Jeremy R.; Wesson, Roger; Zijlstra, Albert A. "The messy death of a multiple star system and the resulting planetary nebula as observed by JWST," *Nature Astronomy*, 6: 1421, 2022.
- De Sarkar, Agnibha; Roy, Nirupam; Majumdar, Pratik; Gupta, Nayantara; Brunthaler, Andreas; Menten, Karl M.; Dzib, Sergio A.; Medina, Sac Nicté X.; Wyrowski, Friedrich "Possible TeV Gamma-Ray Binary Origin of HESS J1828-099," *The Astrophysical Journal*, 927: L35, 2022.
- De Simone, Marta; Ceccarelli, Cecilia; Codella, Claudio; Svoboda, Brian E.; Chandler, Claire J.; Bouvier, Mathilde; Yamamoto, Satoshi; Sakai, Nami; Yang, Yao-Lun; Caselli, Paola; Lefloch, Bertrand; Liu, Haoyu Baobab; López-Sepulcre, Ana; Loinard, Laurent; Pineda, Jaime E.; Testi, Leonardo "Tracking the Ice Mantle History in the Solar-type Protostars of NGC 1333 IRAS 4," *The Astrophysical Journal*, 935: L14, 2022.
- De Valon, A.; Dougados, C.; Cabrit, S.; Louvet, F.; Zapata, L. A.; Mardones, D. "Modeling the CO outflow in DG Tauri B: Swept-up shells versus perturbed MHD disk wind," *Astronomy and Astrophysics*, 668: A78, 2022.
- De Villiers, Mattieu S.; Cotton, William D. "MeerKAT Primary-beam Measurements in the L Band," *The Astronomical Journal*, 163: 135, 2022.
- Decarli, Roberto; Pensabene, Antonio; Venemans, Bram; Walter, Fabian; Bañados, Eduardo; Bertoldi, Frank; Carilli, Chris L.; Cox, Pierre; Fan, Xiaohui; Farina, Emanuele Paolo; Ferkinhoff, Carl; Groves, Brent A.; Li, Jianan; Mazzucchelli, Chiara; Neri, Roberto; Riechers, Dominik A.; Uzgil, Bade; Wang, Feige; Wang, Ran; Weiss, Axel; Winters, Jan Martin; Yang, Jinyi "Molecular gas in  $z \sim 6$  quasar host galaxies," *Astronomy and Astrophysics*, 662: A60, 2022.
- Decker, Brandon; Brodwin, Mark; Saha, Ripon; Connor, Thomas; Eisenhardt, Peter R. M.; Gonzalez, Anthony H.; Moravec, Emily; Muhibullah, Mustafa; Stanford, S. Adam; Stern, Daniel; Thongkham, Khunanon; Wylezalek, Dominika; Dicker, Simon R.; Mason, Brian; Mroczkowski, Tony; Romero, Charles E.; Ruppin, Florian "The Massive and Distant Clusters of WISE Survey. XI. Stellar Mass Fractions and Luminosity Functions of MaDCoWS Clusters at  $z \sim 1$ ," *The Astrophysical Journal*, 936: 71, 2022.
- Deconto-Machado, Alice; Del Olmo, Ascensión; Marziani, Paola; Perea, Jaime; Stirpe, Giovanna "Optical and UV properties of a radio-loud and a radio-quiet Population A quasar at high redshift," *Astronomische Nachrichten*, 343: e210084, 2022.
- Delvecchio, I.; Daddi, E.; Sargent, M. T.; Aird, J.; Mullaney, J. R.; Magnelli, B.; Elbaz, D.; Bisigello, L.; Ceraj, L.; Jin, S.; Kalita, B. S.; Liu, D.; Novak, M.; Prandoni, I.; Radcliffe, J. F.; Spingola, C.; Zamorani, G.; Allevato, V.; Rodighiero, G.; Smolčić, V. "A super-linear radio-AGN main sequence' links mean radio-AGN power and galaxy stellar mass since  $z \sim 3$ ," *Astronomy and Astrophysics*, 668: A81, 2022.
- Demarchi, Lindsay; Margutti, R.; Dittman, J.; Brunthaler, A.; Milisavljevic, D.; Bietenholz, Michael F.; Stauffer, C.; Brethauer, D.; Coppejans, D.; Auchettl, K.; Alexander, K. D.; Kilpatrick, C. D.; Bright, Joe S.; Kelley, L. Z.; Stroh, Michael C.; Jacobson-Galán, W. V. "Radio Analysis of SN2004C Reveals an Unusual CSM Density Profile as a Harbinger of Core Collapse," *The Astrophysical Journal*, 938: 84, 2022.
- Den Brok, Jakob S.; Bigiel, Frank; Sliwa, Kazimierz; Saito, Toshiki; Usero, Antonio; Schinnerer, Eva; Leroy, Adam K.; Jiménez-Donaire, María J.; Rosolowsky, Erik; Barnes, Ashley T.; Puschnig, Johannes; Pety, Jérôme; Schrubba, Andreas; Bešlić, Ivana; Cao, Yixian; Eibensteiner, Cosima; Glover, Simon C. O.; Klessen, Ralf S.; Diederik Kruijssen, J. M.; Meidt, Sharon E.; Neumann, Lukas; Tomičić, Neven; Pan, Hsi-An; Querejeta, Miguel; Watkins, Elizabeth; Williams, Thomas G.; Wilner, David "A CO isotopologue Line Atlas within the Whirlpool galaxy Survey (CLAWS)," *Astronomy and Astrophysics*, 662: A89, 2022.
- Depolo, Donna L.; Plotkin, Richard M.; Miller-Jones, James C. A.; Strader, Jay; Maccarone, Thomas J.; O'Doherty, Tyrone N.; Chomiuk, Laura; Gallo, Elena "The flickering radio jet from the quiescent black hole X-ray binary A0620-00," *Monthly Notices of the Royal Astronomical Society*, 516: 4640, 2022.
- Dewangan, L. K. "New evidences in IRDC G333.73+0.37: colliding filamentary clouds, hub-filament system, and embedded cores," *Monthly Notices of the Royal Astronomical Society*, 2204: , 2022.
- Dewangan, L. K.; Zinchenko, I. I.; Zemlyanukha, P. M.; Liu, S.-Y.; Su, Y.-N.; Kurtz, S. E.; Ojha, D. K.; Pazukhin, A. G.; Mayya, Y. D. "The Disk-Outflow System around the Rare Young O-type Protostar W42-MME," *The Astrophysical Journal*, 925: 41, 2022.
- Dey, Jyotirmoy; Pandian, Jagadheep D.; Lal, Dharam Vir "Gas Dynamics in the Star-forming Region G18.148-0.283: Is It a Manifestation of Two Colliding Molecular Clouds?," *The Astrophysical Journal*, 925: 60, 2022.
- Dey, Subhrata; Goyal, Arti; Małek, Katarzyna; Galvin, Timothy J.; Seymour, Nicholas; Santos, Tanio Díaz; Piotrowska, Julia; Charmandaris, Vassilis "Low-frequency Radio Continuum Imaging and SED Modeling of 11 LIRGs: Radio-only and FUV to Radio Bands," *The Astrophysical Journal*, 938: 152, 2022.
- Diana, A.; Caccianiga, A.; Ighina, L.; Belladitta, S.; Moretti, A.; Della Ceca, R. "The evolution of the heaviest supermassive black holes in jetted AGNs," *Monthly Notices of the Royal Astronomical Society*, 511: 5436, 2022.
- Diaz-Rodríguez, Ana K.; Anglada, Guillem; Blázquez-Calero, Guillermo; Osorio, Mayra; Gómez, José F.; Fuller, Gary A.; Estalella, Robert; Torrelles, José M.; Cabrit, Sylvie; Rodríguez, Luis F.; Lefèvre, Charlene; Macías, Enrique; Carrasco-González, Carlos; Zapata, Luis A.; De Gregorio-Monsalvo, Itziar; Ho, Paul T. P. "The Physical Properties of the SVS 13 Protobinary System: Two Circumstellar Disks and a Spiraling Circumbinary Disk in the Making," *The Astrophysical Journal*, 930: 91, 2022.
- Dichiara, S.; Troja, E.; Lipunov, V.; Ricci, R.; Oates, S. R.; Butler, N. R.; Liuzzo, E.; Ryan, G.; O'Connor, B.; Cenko, S. B.; Cosentino, R. G.; Lien, A. Y.; Gorbvskoy, E.; Tyurina, N.; Balanutsa, P.; Vlasenko, D.; Gorbunov, I.; Podesta, R.; Podesta, F.; Rebol, R.; Serra, M.; Buckley, D. A. H. "The early afterglow of GRB 190829A," *Monthly Notices of the Royal Astronomical Society*, 512: 2337, 2022.
- Dodson, R.; Momjian, E.; Pisano, D. J.; Luber, N.; Blue Bird, J.; Rozgonyi, K.; Smith, E. T.; Van Gorkom, J. H.; Lucero, D.; Hess, K. M.; Yun, M.; Rhee, J.; Van Der Hulst, J. M.; Vinsen, K.; Meyer, M.; Fernandez, X.; Gim, H. B.; Popping, A.; Wilcots, E. "CHILES. VII. Deep Imaging for the CHILES Project, an SKA Prototype," *The Astronomical Journal*, 163: 59, 2022.
- Doherty, M. J.; Geach, J. E.; Ivison, R. J.; Menten, K. M.; Jacob, A. M.; Forbrich, J.; Dye, S. "Ammonia in the interstellar medium of a starbursting disc at  $z = 2.6$ ," *Monthly Notices of the Royal Astronomical Society*, 517: L60, 2022.
- Dong, Ruobing; Liu, Haoyu Baobab; Cuello, Nicolás; Pinte, Christophe;

- Ábrahám, Péter; Vorobyov, Eduard; Hashimoto, Jun; Kóspál, Ágnes; Chiang, Eugene; Takami, Michihiro; Chen, Lei; Dunham, Michael; Fukagawa, Misato; Green, Joel; Hasegawa, Yasuhiro; Henning, Thomas; Pavlyuchenkov, Yaroslav; Pyo, Tae-Soo; Tamura, Motohide "A likely flyby of binary protostar Z CMa caught in action," *Nature Astronomy*, 6: 331, 2022.
- Donovan Meyer, Jennifer; Corvillón, Andrea; Carpenter, John M.; Plunkett, Adele L.; Kurowski, Robert; Chalevin, Alex; Bruenker, Jakob; Kim, D.-C.; Macías, Enrique "Analysis of the ALMA Cycle 8 Distributed Peer Review Process," *Bulletin of the American Astronomical Society*, 54: 043, 2022.
- Douglas, Andrew; Padmanabh, Prajwal V.; Ransom, Scott M.; Ridolfi, Alessandro; Freire, Paulo; Krishnan, Vivek Venkatraman; Barr, Ewan D.; Pallanca, Cristina; Cadelano, Mario; Possenti, Andrea; Stairs, Ingrid; Hessels, Jason W. T.; Decesar, Megan E.; Lynch, Ryan S.; Bailes, Matthew; Burgay, Marta; Champion, David J.; Karuppusamy, Ramesh; Kramer, Michael; Stappers, Benjamin; Vleeschower, Laila "Two New Black Widow Millisecond Pulsars in M28," *The Astrophysical Journal*, 927: 126, 2022.
- Douglass, Kelly A.; Demina, Regina "Dependence of the Ratio of Total to Visible Mass on Observable Properties of Sloan Digital Sky Survey MaNGA Galaxies," *The Astrophysical Journal*, 925: 127, 2022.
- Driessen, L. N.; Stappers, B. W.; Tremou, E.; Fender, R. P.; Woudt, P. A.; Armstrong, R.; Bloemen, S.; Groot, P.; Heywood, I.; Horesh, A.; Van Der Horst, A. J.; Koerding, E.; McBride, V. A.; Miller-Jones, J. C. A.; Mooley, K. P.; Rowlinson, A.; Wijers, R. A. M. J. "21 new long-term variables in the GX 339-4 field: two years of MeerKAT monitoring," *Monthly Notices of the Royal Astronomical Society*, 512: 5037, 2022.
- Drozdovskaya, Maria N.; Coudert, Laurent H.; Margules, Laurent; Coutens, Audrey; Jørgensen, Jes K.; Manigand, Sébastien "Successive deuteration in low-mass star-forming regions: The case of D<sub>2</sub>-methanol (CHD<sub>2</sub>OH) in IRAS 16293-2422," *Astronomy and Astrophysics*, 659: A69, 2022.
- Dutta, Somnath; Lee, Chin-Fei; Hirano, Naomi; Liu, Tie; Johnstone, Doug; Liu, Sheng-Yuan; Tatematsu, Ken'Ichi; Goldsmith, Paul F.; Sahu, Dipen; Evans, Neal J.; Sanhueza, Patricio; Kwon, Woojin; Qin, Sheng-Li; Samal, Manash Ranjan; Zhang, Qizhou; Kim, Kee-Tae; Shang, Hsien; Lee, Chang Won; Moraghan, Anthony; Jhan, Kai-Syun; Li, Shanghuo; Lee, Jeong-Eun; Traficante, Alessio; Juvela, Mika; Bronfman, Leonardo; Eden, David; Soam, Archana; He, Jinhua; Liu, Hong-Li; Kuan, Yi-Jehng; Pelkonen, Veli-Matti; Luo, Qiuyi; Yi, Hee-Weon; Hsu, Shih-Ying "ALMA Survey of Orion Planck Galactic Cold Clumps (ALMASOP): Evidence for a Molecular Jet Launched at an Unprecedented Early Phase of Protostellar Evolution," *The Astrophysical Journal*, 931: 130, 2022.
- Dutta, Somnath; Lee, Chin-Fei; Johnstone, Doug; Liu, Tie; Hirano, Naomi; Liu, Sheng-Yuan; Lee, Jeong-Eun; Shang, Hsien; Tatematsu, Ken'Ichi; Kim, Kee-Tae; Sahu, Dipen; Sanhueza, Patricio; Di Francesco, James; Jhan, Kai-Syun; Lee, Chang Won; Kwon, Woojin; Li, Shanghuo; Bronfman, Leonardo; Liu, Hong-Li; Traficante, Alessio; Kuan, Yi-Jehng; Hsu, Shih-Ying; Moraghan, Anthony; Liu, Chun-Fan; Eden, David; Soam, Archana; Luo, Qiuyi; (Almasop Team) "ALMA Survey of Orion Planck Galactic Cold Clumps (ALMASOP): Detection of a Dense SiO Jet in the Evolved Protostellar Phase," *The Astrophysical Journal*, 925: 11, 2022.
- Dye, S.; Eales, S. A.; Gomez, H. L.; Jones, G. C.; Smith, M. W. L.; Borsato, E.; Moss, A.; Dunne, L.; Maresca, J.; Amvrosiadis, A.; Negrello, M.; Marchetti, L.; Corsini, E. M.; Ivson, R. J.; Bendo, G. J.; Bakx, T.; Cooray, A.; Cox, P.; Dannerbauer, H.; Serjeant, S.; Riechers, D.; Temi, P.; Vlahakis, C. "A High-Resolution Investigation of the Multi-Phase ISM in a Galaxy during the First Two Billion Years," *Monthly Notices of the Royal Astronomical Society*, 510: 3734, 2022.
- Dzenis, Karlis; Faure, Alexandre; Mcguire, B. A.; Remijan, A. J.; Dagdigan, P. J.; Rist, C.; Dawes, R.; Quintas-Sánchez, E.; Lique, F.; Hochlaf, M. "Collisional Excitation and Non-LTE Modeling of Interstellar Chiral Propylene Oxide," *The Astrophysical Journal*, 926: 3, 2022.
- Efstathiou, A.; Farrah, D.; Afonso, J.; Clements, D. L.; González-Alfonso, E.; Lacy, M.; Oliver, S.; Lesta, V. Papadopoulou; Pearson, C.; Rigopoulou, D.; Rowan-Robinson, M.; Spoon, H. W. W.; Verma, A.; Wang, L. "A new look at local ultraluminous infrared galaxies: The atlas and radiative transfer models of their complex physics," *Monthly Notices of the Royal Astronomical Society*, 512: 5183-5213, 2022.
- Egusa, Fumi; Gao, Yulong; Morokuma-Matsui, Kana; Liu, Guilin; Maeda, Fumiya "CO Excitation and its Connection to Star Formation at 200 pc in NGC 1365," *The Astrophysical Journal*, 935: 64, 2022.
- Eibensteiner, C.; Barnes, A. T.; Bigiel, F.; Schinnerer, E.; Liu, D.; Meier, D. S.; Usero, A.; Leroy, A. K.; Rosolowsky, E.; Puschig, J.; Lazar, I.; Pety, J.; Lopez, L. A.; Emsellem, E.; Bešlić, I.; Querejeta, M.; Murphy, E. J.; Den Brok, J.; Schruha, A.; Chevanche, M.; Glover, S. C. O.; Gao, Y.; Grasha, K.; Hassani, H.; Henshaw, J. D.; Jimenez-Donaire, M. J.; Klessen, R. S.; Kruijssen, J. M. D.; Pan, H.-A.; Saito, T.; Sormani, M. C.; Teng, Y.-H.; Williams, T. G. "A 2-3 mm high-resolution molecular line survey towards the centre of the nearby spiral galaxy NGC 6946," *Astronomy and Astrophysics*, 659: A173, 2022.
- Elmegreen, Bruce G.; Martinez, Zorayda; Hunter, Deidre A. "A Search for Correlations between Turbulence and Star Formation in THINGS Galaxies," *The Astrophysical Journal*, 928: 143, 2022.
- Emig, K. L.; White, G. J.; Salas, P.; Karim, R. L.; Van Weeren, R. J.; Teuben, P. J.; Zavagno, A.; Chiu, P.; Haverkorn, M.; Oonk, J. B. R.; Orrú, E.; Polderman, I. M.; Reich, W.; Röttgering, H. J. A.; Tielens, A. G. G. M. "Filamentary structures of ionized gas in Cygnus X," *Astronomy and Astrophysics*, 664: A88, 2022.
- Endsley, Ryan; Stark, Daniel P.; Bouwens, Rychard J.; Schouws, Sander; Smit, Renske; Stefanon, Mauro; Inami, Hanae; Bowler, Rebecca A. A.; Oesch, Pascal; Gonzalez, Valentino; Aravena, Manuel; Da Cunha, Elisabete; Dayal, Pratika; Ferrara, Andrea; Graziani, Luca; Nanayakkara, Themiya; Pallottini, Andrea; Schneider, Raffaella; Sommovigo, Laura; Topping, Michael; Van Der Werf, Paul; Hutter, Anne "The REBELS ALMA Survey: efficient Ly  $\alpha$  transmission of UV-bright  $z \sim 7$  galaxies from large velocity offsets and broad line widths," *Monthly Notices of the Royal Astronomical Society*, 517: 5642, 2022.
- Endsley, Ryan; Stark, Daniel P.; Fan, Xiaohui; Smit, Renske; Wang, Feige; Yang, Jinyi; Hainline, Kevin; Lyu, Jianwei; Bouwens, Rychard; Schouws, Sander "Radio and far-IR emission associated with a massive star-forming galaxy candidate at  $z \sim 6.8$ : a radio-loud AGN in the reionization era?," *Monthly Notices of the Royal Astronomical Society*, 512: 4248, 2022.
- Enia, Andrea; Talia, Margherita; Pozzi, Francesca; Cimatti, Andrea; Delvecchio, Ivan; Zamorani, Gianni; D'Amato, Quirino; Bisigello, Laura; Gruppioni, Carlotta; Rodighiero, Giulia; Calura, Francesco; Dallacasa, Daniele; Giulietti, Marika; Barchiesi, Luigi; Behiri, Meriem; Romano, Michael "A New Estimate of the Cosmic Star Formation Density from a Radio-selected Sample, and the Contribution of H-dark Galaxies at  $z \geq 3$ ," *The Astrophysical Journal*, 927: 204, 2022.
- Espaillet, C. C.; Macías, E.; Wendeborn, J.; Franco-Hernández, R.; Calvet, N.; Rillinger, A.; Cleeves, L. I.; D'Alessio, P. "Testing the Potential for Radio Variability in Disks around T Tauri Stars with Observations and Chemical Modeling," *The Astrophysical Journal*, 924: 104, 2022.
- Espinoza, C. M.; Vidal-Navarro, M.; Ho, W. C. G.; Deller, A.; Chatterjee, S. "VLA proper motion constraints on the origin, age, and potential magnetar future of PSR J1734-3333," *Astronomy and Astrophysics*, 659: A41, 2022.
- Esposito, Federico; Vallini, Livia; Pozzi, Francesca; Casasola, Viviana; Mingozzi, Matilde; Vignali, Cristian; Gruppioni, Carlotta; Salvestrini, Francesco "AGN impact on the molecular gas in galactic centres as probed by CO lines," *Monthly Notices of the Royal Astronomical Society*, 512: 686, 2022.
- Evans, A. S.; Frayer, D. T.; Charmandaris, Vassilis; Armus, Lee; Inami, Hanae; Surace, Jason; Linden, Sean; Soifer, B. T.; Diaz-Santos, Tanio; Larson, Kirsten L.; Rich, Jeffrey A.; Song, Yiqing; Barcos-Munoz, Loreto; Mazzarella, Joseph M.; Privo, George C.; U, Vivian; Medling, Anne M.; Böker, Torsten; Aalto, Susanne; Iwasawa, Kazushi; Howell, Justin H.; Van Der Werf, Paul; Appleton, Philip; Bohn, Thomas; Brown, Michael

## APPENDIX A: PUBLICATIONS

- J. I.; Hayward, Christopher C.; Hoshioka, Shunshi; Kemper, Francisca; Lai, Thomas; Law, David; Malkan, Matthew A.; Marshall, Jason; Murphy, Eric J.; Sanders, David; Stierwalt, Sabrina "GOALS-JWST: Hidden Star Formation and Extended PAH Emission in the Luminous Infrared Galaxy VV 114," *The Astrophysical Journal*, 940: L8, 2022.
- Evans, L.; Fontani, F.; Vastel, C.; Ceccarelli, C.; Caselli, P.; López-Sepulcre, A.; Neri, R.; Alves, F.; Chahine, L.; Favre, C.; Lattanzi, V. "SOLIS. XIII. Nitrogen fractionation towards the protocluster OMC-2 FIR4," *Astronomy and Astrophysics*, 657: A136, 2022.
- Farah, Joseph; Galison, Peter; Akiyama, Kazunori; Bouman, Katherine L.; Bower, Geoffrey C.; Chael, Andrew; Fuentes, Antonio; Gómez, José L.; Honma, Mareki; Johnson, Michael D.; Kofuji, Yutaro; Marrone, Daniel P.; Moriyama, Kotaro; Narayan, Ramesh; Pesce, Dominic W.; Tiede, Paul; Wielgus, Maciek; Zhao, Guang-Yao; Alberdi, Antxon; Alef, Walter; Algaba, Juan Carlos; Anantua, Richard; Asada, Keiichi; Azulay, Rebecca; Baczko, Anne-Kathrin; Ball, David; Baloković, Mislav; Barrett, John; Benson, Bradford A.; Bintley, Dan; Blackburn, Lindy; Blundell, Raymond; Boland, Wilfred; Boyce, Hope; Bremer, Michael; Brinkerink, Christiaan D.; Brissenden, Roger; Britzen, Silke; Broderick, Avery E.; Brogiere, Dominique; Bronzwaer, Thomas; Bustamente, Sandra; Byun, Do-Young; Carlstrom, John E.; Chan, Chi-Kwan; Chatterjee, Koushik; Chatterjee, Shami; Chen, Ming-Tang; Chen, Yongjun; Cho, Ilje; Christian, Pierre; Conway, John E.; Cordes, James M.; Crawford, Thomas M.; Crew, Geoffrey B.; Cruz-Osorio, Alejandro; Cui, Yuzhu; Davelaar, Jordy; Laurentis, Mariafelicia De; Deane, Roger; Dempsey, Jessica; Desvignes, Gregory; Doleman, Sheperd S.; Eatough, Ralph P.; Falcke, Heino; Fish, Vincent L.; Fomalont, Ed; Ford, H. Alyson; Fraga-Encinas, Raquel; Friberg, Per; Fromm, Christian M.; Gammie, Charles F.; Garc'A, Roberto; Gentaz, Olivier; Goddi, Ciriaco; Gold, Roman; Gómez-Ruiz, Arturo I.; Gu, Minfeng; Gurwell, Mark; Hada, Kazuhiro; Haggard, Daryl; Hecht, Michael H.; Hesper, Ronald; Ho, Luis C.; Ho, Paul; Huang, Chih-Wei L.; Huang, Lei; Hughes, David H.; Ikeda, Shiro; Inoue, Makoto; Issaoun, Sara; James, David J.; Jannuzi, Buell T.; Janssen, Michael; Jeter, Britton; Jiang, Wu; Jimenez-Rosales, Alejandra; Jorstad, Svetlana; Jung, Taehyun; Karami, Mansour; Karuppusamy, Ramesh; Kawashima, Tomohisa; Keating, Garrett K.; Kettenis, Mark; Kim, Dong-Jin; Kim, Jae-Young; Kim, Jongsoo; Kim, Junhan; Kino, Motoki; Koay, Jun Yi; Koch, Patrick M.; Koyama, Shoko; Kramer, Carsten; Kramer, Michael; Krichbaum, Thomas P.; Kuo, Cheng-Yu; Lauer, Tod R.; Lee, Sang-Sung; Levis, Aviad; Li, Yan-Rong; Li, Zhiyuan; Lico, Rocco; Lindahl, Greg; Lindqvist, Michael; Liu, Jun; Liu, Kuo; Liuzzo, Elisabetta; Lo, Wen-Ping; Lobanov, Andrei P.; Loinard, Laurent; Lonsdale, Colin; Lu, Ru-Sen; Macdonald, Nicholas R.; Mao, Jirong; Marchili, Nicola; Markoff, Sera; Marscher, Alan P.; Martí-Vidal, Iván; Matsushita, Satoki; Matthews, Lynn D.; Medeiros, Lia; Menten, Karl M.; Mizuno, Izumi; Mizuno, Yosuke; Moran, James M.; Moscibrodzka, Monika; Müller, Cornelia; Mejias, Alejandro Mus; Musoke, Gibwa; Nagai, Hiroshi; Nagar, Neil M.; Nakamura, Masanori; Narayanan, Gopal; Natarajan, Iniyang; Nathanail, Antonios; Neilsen, Joey; Neri, Roberto; Ni, Chunhong; Noutsos, Aristeidis; Nowak, Michael A.; Okino, Hiroki; Olivares, Héctor; Ortiz-León, Gisela N.; Oyama, Tomoaki; Zel, Feryal; Palumbo, Daniel C. M.; Park, Jongho; Patel, Nimesh; Pen, Ue-Li; Piétu, Vincent; Plambeck, Richard; Popstefanija, Aleksandar; Porth, Oliver; Pözl, Felix M.; Prather, Ben; Preciado-López, Jorge A.; Psaltis, Dimitrios; Pu, Hung-Yi; Ramakrishnan, Venkatesh; Rao, Ramprasad; Rawlings, Mark G.; Raymond, Alexander W.; Rezzolla, Luciano; Ripperda, Bart; Roelofs, Freek; Rogers, Alan; Ros, Eduardo; Rose, Mel; Roshanineshat, Arash; Rottmann, Helge; Roy, Alan L.; Ruszczyk, Chet; Rygl, Kazi L. J.; Sánchez, Salvador; Sánchez-Argüelles, David; Sasada, Mahito; Savolainen, Tuomas; Schloerb, F. Peter; Schuster, Karl-Friedrich; Shao, Lijing; Shen, Zhiqiang; Small, Des; Sohn, Bong Won; Soohoo, Jason; Sun, He; Tazaki, Fumie; Tetarenko, Alexandra J.; Tilanus, Remo P. J.; Titus, Michael; Toma, Kenji; Torne, Pablo; Traianou, Eftalia; Trent, Tyler; Trippe, Sascha; Bimmel, Ilse Van; Van Langevelde, Huib Jan; Van Rossum, Daniel R.; Wagner, Jan; Ward-Thompson, Derek; Wardle, John; Weintraub, Jonathan; Wex, Norbert; Wharton, Robert; Wiik, Kaj; Wong, George N.; Wu, Qingwen; Yoon, Doosoo; Young, André; Young, Ken; Younsi, Ziri; Yuan, Feng; Yuan, Ye-Fei; Zensus, J. Anton; Zhao, Shan-Shan; Event Horizon Telescope Collaboration "Selective Dynamical Imaging of Interferometric Data," *The Astrophysical Journal*, 930: L18, 2022.
- Farrah, Duncan; Efstathiou, Andreas; Afonso, Jose; Bernard-Salas, Jeronimo; Cairns, Joe; Clements, David L.; Croker, Kevin; Hatziminaoglou, Evanthis; Joyce, Maya; Lacy, Mark; Lebouteller, Vianney; Lieblisch, Alix; Lonsdale, Carol; Oliver, Seb; Pearson, Chris; Petty, Sara; Pitchford, Lura K.; Rigopoulou, Dimitra; Rowan-Robinson, Michael; Runburg, Jack; Spoon, Henrik; Verma, Aprajita; Wang, Lingyu "Stellar and black hole assembly in  $z < 0.3$  infrared-luminous mergers: Intermittent starbursts versus super-Eddington accretion," *Monthly Notices of the Royal Astronomical Society*, 513: 4770-4786, 2022.
- Fehr, Anna J.; Hughes, A. Meredith; Dawson, Rebekah I.; Marino, Rachel E.; Ackelsberg, Matan; Kittling, Jamar; Flaherty, Kevin M.; Nesvold, Erika; Carpenter, John; Andrews, Sean M.; Matthews, Brenda; Crotts, Katie; Kalas, Paul "Millimeter Dust Emission and Planetary Dynamics in the HD 106906 System," *The Astrophysical Journal*, 939: 56, 2022.
- Feng, Shuai; Shen, Shi-Yin; Yuan, Fang-Ting; Dai, Y. Sophia; Masters, Karen L. "The Velocity Map Asymmetry of Ionized Gas in MaNGA. I. The Catalog and General Properties," *The Astrophysical Journal Supplement Series*, 262: 6, 2022.
- Feng, Yi; Li, Di; Yang, Yuan-Pei; Zhang, Yongkun; Zhu, Weiwei; Zhang, Bing; Lu, Wenbin; Wang, Pei; Dai, Shi; Lynch, Ryan S.; Yao, Jumei; Jiang, Jinchen; Niu, Jiarui; Zhou, Dejiang; Xu, Heng; Miao, Chenchen; Niu, Chenhui; Meng, Lingqi; Qian, Lei; Tsai, Chao-Wei; Wang, Bojun; Xue, Mengyao; Yue, Youling; Yuan, Mao; Zhang, Songbo; Zhang, Lei "Frequency-dependent polarization of repeating fast radio bursts—implications for their origin," *Science*, 375: 1266, 2022.
- Fermi-Lat Collaboration; Ajello, M.; Atwood, W. B.; Baldini, L.; Ballet, J.; Barbiellini, G.; Bastieri, D.; Bellazzini, R.; Berretta, A.; Bhattacharyya, B.; Bissaldi, E.; Blandford, R. D.; Bloom, E.; Bonino, R.; Bruel, P.; Buehler, R.; Burns, E.; Buson, S.; Cameron, R. A.; Caraveo, P. A.; Cavazzuti, E.; Cibrario, N.; Ciprini, S.; Clark, C. J.; Cognard, I.; Coronado-Blázquez, J.; Crnogorčević, M.; Cromartie, H.; Crowter, K.; Cutini, S.; D'Ammando, F.; De Gaetano, S.; De Palma, F.; Digel, S. W.; Di Lalla, N.; Fana Dirirsa, F.; Di Venere, L.; Domínguez, A.; Ferrara, E. C.; Fiori, A.; Frankowski, A.; Fukazawa, Y.; Funk, S.; Fusco, P.; Gammaldi, V.; Gargano, F.; Gasparrini, D.; Giglietto, N.; Giordano, F.; Giroletti, M.; Green, D.; Grenier, I. A.; Guillemot, L.; Guiriec, S.; Gustafsson, M.; Harding, A. K.; Hays, E.; Hewitt, J. W.; Horan, D.; Hou, X.; Jóhannesson, G.; Keith, M. J.; Kerr, M.; Kramer, M.; Kuss, M.; Larsson, S.; Latronico, L.; Li, J.; Longo, F.; Loparco, F.; Lovellette, M. N.; Lubrano, P.; Maldera, S.; Manfreda, A.; Martí-Devesa, G.; Mazziotta, M. N.; Mereu, I.; Michelson, P. F.; Mirabal, N.; Mitthumsiri, W.; Mizuno, T.; Monzani, M. E.; Morselli, A.; Negro, M.; Nieder, L.; Ojha, R.; Omodei, N.; Orienti, M.; Orlando, E.; Ormes, J. F.; Paneque, D.; Parthasarathy, A.; Pei, Z.; Persic, M.; Pesce-Rollins, M.; Pillera, R.; Poon, H.; Porter, T. A.; Principe, G.; Racusin, J. L.; Rainò, S.; Rando, R.; Rani, B.; Ransom, S. M.; Ray, P. S.; Razzano, M.; Razaque, S.; Reimer, A.; Reimer, O.; Roy, J.; Sánchez-Conde, M.; Saz Parkinson, P. M.; Scargle, J.; Scotton, L.; Serini, D.; Sgrò, C.; Siskind, E. J.; Smith, D. A.; Spandre, G.; Spiewak, R.; Spinelli, P.; Stairs, I.; Suson, D. J.; Swihart, S. J.; Tabassum, S.; Thayer, J. B.; Theureau, G.; Torres, D. F.; Troja, E.; Valverde, J.; Wadiasingh, Z.; Wood, K.; Zaharijas, G. "A gamma-ray pulsar timing array constrains the nanohertz gravitational wave background," *Science*, 376: 521, 2022.
- Fernandez, Luis C.; Secrest, Nathan J.; Johnson, Megan C.; Schmitt, Henrique R.; Fischer, Travis C.; Cigan, Phillip J.; Dorland, Bryan N. "FRAMEx. II. Simultaneous X-Ray and Radio Variability in Active Galactic Nuclei-The Case of NGC 2992," *The Astrophysical Journal*, 927: 18, 2022.
- Ferrara, A.; Sommovigo, L.; Dayal, P.; Pallottini, A.; Bouwens, R. J.; Gonzalez, V.; Inami, H.; Smit, R.; Bowler, R. A. A.; Endsley, R.; Oesch, P.; Schouws,



- S.; Stark, D.; Stefanon, M.; Aravena, M.; Da Cunha, E.; De Looze, I.; Fudamoto, Y.; Graziani, L.; Hodge, J.; Riechers, D.; Schneider, R.; Algera, H. S. B.; Barrufet, L.; Hygate, A. P. S.; Labbé, I.; Li, C.; Nanayakkara, T.; Topping, M.; Van Der Werf, P. "The ALMA REBELS Survey. Epoch of Reionization giants: Properties of dusty galaxies at  $z \sim 7$ ," *Monthly Notices of the Royal Astronomical Society*, 512: 58, 2022.
- Finn, Molly K.; Indebetouw, Remy; Johnson, Kelsey E.; Costa, Allison H.; Chen, C.-H. Rosie; Kawamura, Akiko; Onishi, Toshikazu; Ott, Jürgen; Sewito, Marta; Tokuda, Kazuki; Wong, Tony; Zahorec, Sarolta "Structural and Dynamical Analysis of the Quiescent Molecular Ridge in the Large Magellanic Cloud," *The Astronomical Journal*, 164: 64, 2022.
- Flanagan, C. J. P.; Ellingsen, S. P.; Cole, A. A. "A sensitive search for water masers associated with star formation regions in the Local Group Galaxy NGC 6822," *Publications of the Astronomical Society of Australia*, 39: e022, 2022.
- Fogasy, J.; Knudsen, K. K.; Varenus, E. "VLA detects CO(1-0) emission in the  $z = 3.65$  quasar SDSS J160705+533558," *Astronomy and Astrophysics*, 660: A60, 2022.
- Fong, Wen-Fai; Nugent, Anya E.; Dong, Yuxin; Berger, Edo; Paterson, Kerry; Chornock, Ryan; Levan, Andrew; Blanchard, Peter; Alexander, Kate D.; Andrews, Jennifer; Cobb, Bethany E.; Cucchiara, Antonino; Fox, Derek; Fryer, Chris L.; Gordon, Alexa C.; Kilpatrick, Charles D.; Lunan, Ragnhild; Margutti, Raffaella; Miller, Adam; Milne, Peter; Nicholl, Matt; Perley, Daniel; Rastinejad, Jillian; Escorial, Alicia Rouco; Schroeder, Genevieve; Smith, Nathan; Tanvir, Nial; Terreran, Giacomo "Short GRB Host Galaxies. I. Photometric and Spectroscopic Catalogs, Host Associations, and Galactocentric Offsets," *The Astrophysical Journal*, 940: 56, 2022.
- Fornasini, Francesca M.; Elvis, Martin; Maksym, W. Peter; Fabbiano, Giuseppina; Bergmann, Thaisa Storchi; Gandhi, Poshak; Whittle, Mark "Termination Shocks and the Extended X-Ray Emission in Mrk 78," *The Astrophysical Journal*, 931: 65, 2022.
- Foss, Marie K.; Ihle, Håvard T.; Borowska, Jowita; Cleary, Kieran A.; Eriksen, Hans Kristian; Harper, Stuart E.; Kim, Junhan; Lamb, James W.; Lunde, Jonas G. S.; Philip, Liju; Rasmussen, Maren; Stutzer, Nils-Ole; Uzgil, Bade D.; Watts, Duncan J.; Wehus, Ingunn K.; Woody, David P.; Bond, J. Richard; Breyse, Patrick C.; Catha, Morgan; Church, Sarah E.; Chung, Dongwoo T.; Dickinson, Clive; Dunne, Delaney A.; Gaier, Todd; Gundersen, Joshua Ott; Harris, Andrew I.; Hobbs, Richard; Lawrence, Charles R.; Murray, Norman; Readhead, Anthony C. S.; Padmanabhan, Hamsa; Pearson, Timothy J.; Rennie, Thomas J.; Comap Collaboration "COMAP Early Science. III. CO Data Processing," *The Astrophysical Journal*, 933: 184, 2022.
- Foster, Joshua W.; Witte, Samuel J.; Lawson, Matthew; Linden, Tim; Gajjar, Vishal; Weniger, Christoph; Safdi, Benjamin R. "Extraterrestrial Axion Search with the Breakthrough Listen Galactic Center Survey," *Physical Review Letters*, 129: 251102, 2022.
- Francis, Logan; Johnstone, Doug; Lee, Jeong-Eun; Herczeg, Gregory J.; Long, Feng; Mairs, Steve; Contreras Peña, Carlos; Moriarty-Schieven, Gerald; Jcmt Transient Team "Accretion Burst Echoes as Probes of Protostellar Environments and Episodic Mass Assembly," *The Astrophysical Journal*, 937: 29, 2022.
- Francis, Logan; Marel, Nienke Van Der; Johnstone, Doug; Akiyama, Eiji; Bruderer, Simon; Dong, Ruobing; Hashimoto, Jun; Liu, Haoyu Baobab; Muto, Takayuki; Yang, Yi "Gap Opening and Inner Disk Structure in the Strongly Accreting Transition Disk of DM Tau," *The Astronomical Journal*, 164: 105, 2022.
- Franz, Noah; Croft, Steve; Siemion, Andrew P. V.; Traas, Raffy; Brzycki, Bryan; Gajjar, Vishal; Isaacson, Howard; Lebofsky, Matthew; Macmahon, David H. E.; Price, Danny C.; Sheikh, Sofia Z.; Demarines, Julia; Drew, Jamie; Worden, S. Pete "The Breakthrough Listen Search for Intelligent Life: Technosignature Search of Transiting TESS Targets of Interest," *The Astronomical Journal*, 163: 104, 2022.
- Frey, Sándor; Gabányi, Krisztina; An, Tao "The Quasar CTD 135 Is Not a Compact Symmetric Object," *Symmetry*, 14: 321, 2022.
- Frias Castillo, Marta; Rybak, Matus; Hodge, Jacqueline; Van Der Werf, Paul; Riechers, Dominik A.; Vieira, Daniel; Calistro Rivera, Gabriela; Martínez-Ramírez, Laura N.; Walter, Fabian; De Blok, Erwin; Narayanan, Desika; Wagg, Jeff "Kiloparsec-scale Imaging of the CO(1-0)-traced Cold Molecular Gas Reservoir in a  $z = 3.4$  Submillimeter Galaxy," *The Astrophysical Journal*, 930: 35, 2022.
- Fu, Shenming; Dell'Antonio, Ian; Chary, Ranga-Ram; Clowe, Douglas; Cooper, M. C.; Donahue, Megan; Evrard, August; Lacy, Mark; Lauer, Tod; Liu, Binyang; McCleary, Jacqueline; Meneghetti, Massimo; Miyatake, Hironao; Montes, Mireia; Natarajan, Priyamvada; Ntampaka, Michelle; Pierpaoli, Elena; Postman, Marc; Sohn, Jubee; Umetsu, Keiichi; Utsumi, Yousuke; Wilson, Gillian "LoVoCCS. I. Survey Introduction, Data Processing Pipeline, and Early Science Results," *The Astrophysical Journal*, 933: 84, 2022.
- Fudamoto, Y.; Smit, R.; Bowler, R. A. A.; Oesch, P. A.; Bouwens, R.; Stefanon, M.; Inami, H.; Endsley, R.; Gonzalez, V.; Schouws, S.; Stark, D.; Algera, H. S. B.; Aravena, M.; Barrufet, L.; Da Cunha, E.; Dayal, P.; Ferrara, A.; Graziani, L.; Hodge, J. A.; Hygate, A. P. S.; Inoue, A. K.; Nanayakkara, T.; Pallottini, A.; Pizzati, E.; Schneider, R.; Sommovigo, L.; Sugahara, Y.; Topping, M.; Van Der Werf, P.; Bethermin, M.; Cassata, P.; Dessauges-Zavadsky, M.; Ibar, E.; Faisst, A. L.; Fujimoto, S.; Ginolfi, M.; Hathi, N.; Jones, G. C.; Pozzi, F.; Schaerer, D. "The ALMA REBELS Survey: Average [C II]  $158 \mu\text{m}$  Sizes of Star-forming Galaxies from  $z = 7$  to  $z = 4$ ," *The Astrophysical Journal*, 934: 144, 2022.
- Fujimoto, S.; Brammer, G. B.; Watson, D.; Magdis, G. E.; Kokorev, V.; Greve, T. R.; Toft, S.; Walter, F.; Valiante, R.; Ginolfi, M.; Schneider, R.; Valentino, F.; Colina, L.; Vestergaard, M.; Marques-Chaves, R.; Fynbo, J. P. U.; Krips, M.; Steinhardt, C. L.; Cortzen, I.; Rizzo, F.; Oesch, P. A. "A dusty compact object bridging galaxies and quasars at cosmic dawn," *Nature*, 604: 261, 2022.
- Gajjar, Vishal; Leduc, Dominic; Chen, Jiani; Siemion, Andrew P. V.; Sheikh, Sofia Z.; Brzycki, Bryan; Croft, Steve; Czech, Daniel; Deboer, David; Demarines, Julia; Drew, Jamie; Isaacson, Howard; Lacki, Brian C.; Lebofsky, Matt; Macmahon, David H. E.; Ng, Cherry; De Pater, Imke; Perez, Karen I.; Price, Danny C.; Suresh, Akshay; Webb, Claire; Worden, S. Pete "Searching for Broadband Pulsed Beacons from 1883 Stars Using Neural Networks," *The Astrophysical Journal*, 932: 81, 2022.
- Galaz, Gaspar; Frayer, David T.; Blaña, Matías; Howk, J. Christopher; Puzia, Thomas; Johnston, Evelyn J.; Ordenes-Briceño, Yasna; Church, Sarah; Gil, Santiago; Joachimi, Katerine; Mora, Marcelo "The Giant Low Surface Brightness Galaxy Malin 1: New Constraints for Its Molecular Gas Mass from GBT/ARGUS Observations," *The Astrophysical Journal*, 940: L37, 2022.
- Gallego-Calvente, A. T.; Schödel, R.; Alberdi, A.; Najarro, F.; Yusef-Zadeh, F.; Shahzamanian, B.; Noguera-Lara, F. "Radio observations of massive stars in the Galactic centre: The Quintuplet cluster," *Astronomy and Astrophysics*, 664: A49, 2022.
- Gómez Rosas, Violeta; Isbell, Jacob W.; Jaffe, Walter; Petrov, Romain G.; Leftley, James H.; Hofmann, Karl-Heinz; Millour, Florentin; Burtscher, Leonard; Meisenheimer, Klaus; Meiland, Anthony; Waters, Laurens B. F. M.; Lopez, Bruno; Lagarde, Stéphane; Weigelt, Gerd; Berio, Philippe; Allouche, Fatme; Robbe-Dubois, Sylvie; Cruzalèbes, Pierre; Bettonvil, Felix; Henning, Thomas; Augereau, Jean-Charles; Antonelli, Pierre; Beckmann, Udo; Van Boekel, Roy; Bendjoya, Philippe; Danchi, William C.; Dominik, Carsten; Drevon, Julien; Gallimore, Jack F.; Graser, Uwe; Heininger, Matthias; Hocdé, Vincent; Hogerheijde, Michiel; Hron, Josef; Impellizzeri, Caterina M. V.; Klarmann, Lucia; Kokoulina, Elena; Labadie, Lucas; Lehmitz, Michael; Matter, Alexis; Paladini, Claudia; Pantin, Eric; Pott, Jörg-Uwe; Schertl, Dieter; Soullain, Anthony; Stee, Philippe; Tristram, Konrad; Varga, Jozsef; Woillez, Julien; Wolf, Sebastian; Yoffe, Gideon; Zins, Gerard "Thermal imaging of dust hiding the black hole in NGC 1068," *Nature*, 602: 403, 2022.
- Gao, Yulong; Gu, Qiusheng; Shi, Yong; Zhou, Luwenjia; Bao, Min; Yu, Xiaoling; Zhang, Zhi-Yu; Wang, Tao; Madden, Suzanne C.; Hayes, Matthew; Lu, Shiyong; Xu, Ke "The molecular gas resolved by ALMA

## APPENDIX A: PUBLICATIONS

- in the low-metallicity merging dwarf galaxy Haro 11," *Astronomy and Astrophysics*, 661: A136, 2022.
- García De La Concepción, J.; Colzi, L.; Jiménez-Serra, I.; Molpeceres, G.; Corchado, J. C.; Rivilla, V. M.; Martín-Pintado, J.; Beltrán, M. T.; Mininni, C. "The trans/cis ratio of formic (HCOOH) and thioformic (HC(O)SH) acids in the interstellar medium," *Astronomy and Astrophysics*, 658: A150, 2022.
- García-Vergara, Cristina; Rybak, Matus; Hodge, Jacqueline; Hennawi, Joseph F.; Decarli, Roberto; González-López, Jorge; Arrigoni-Battaia, Fabrizio; Aravena, Manuel; Farina, Emanuele P. "ALMA Reveals a Large Overdensity and Strong Clustering of Galaxies in Quasar Environments at  $z > 4$ ," *The Astrophysical Journal*, 927: 65, 2022.
- Garg, H.; Pinte, C.; Hammond, I.; Teague, R.; Hilder, T.; Price, D. J.; Calcino, J.; Christiaens, V.; Poblete, P. P. "A kinematic excess in the annular gap and gas-depleted cavity in the disc around HD 169142," *Monthly Notices of the Royal Astronomical Society*, 517: 5942, 2022.
- Garg, Prerak; Narayanan, Desika; Byler, Nell; Sanders, Ryan L.; Shapley, Alice E.; Strom, Allison L.; Davé, Romeel; Hirschmann, Michaela; Lovell, Christopher C.; Otter, Justin; Popping, Gergő; Privon, George C. "The BPT Diagram in Cosmological Galaxy Formation Simulations: Understanding the Physics Driving Offsets at High Redshift," *The Astrophysical Journal*, 926: 80, 2022.
- Garofalo, David; Moravec, Emily; Maccioni, Duccio; Singh, Chandra B. "Is Jet Re-orientation the Elusive Trigger for Star Formation Suppression in Radio Galaxies?," *Publications of the Astronomical Society of the Pacific*, 134: 114101, 2022.
- Garufi, A.; Dominik, C.; Ginski, C.; Benisty, M.; Van Holstein, R. G.; Henning, Th.; Pawellek, N.; Pinte, C.; Avenhaus, H.; Facchini, S.; Galicher, R.; Gratton, R.; Ménard, F.; Muro-Arena, G.; Milli, J.; Stolker, T.; Vigan, A.; Villenave, M.; Moulin, T.; Origne, A.; Rigal, F.; Sauvage, J.-F.; Weber, L. "A SPHERE survey of self-shadowed planet-forming disks," *Astronomy and Astrophysics*, 658: A137, 2022.
- Garufi, A.; Podio, L.; Codella, C.; Segura-Cox, D.; Vander Donckt, M.; Mercimek, S.; Bacciotti, F.; Fedele, D.; Kasper, M.; Pineda, J. E.; Humphreys, E.; Testi, L. "ALMA chemical survey of disk-outflow sources in Taurus (ALMA-DOT). VI. Accretion shocks in the disk of DG Tau and HL Tau," *Astronomy and Astrophysics*, 658: A104, 2022.
- Gautam, T.; Ridolfi, A.; Freire, P. C. C.; Wharton, R. S.; Gupta, Y.; Ransom, S. M.; Oswald, L. S.; Kramer, M.; Decesar, M. E. "Upgraded GMRT survey for pulsars in globular clusters. I. Discovery of a millisecond binary pulsar in NGC 6652," *Astronomy and Astrophysics*, 664: A54, 2022.
- Georgiev, Boris; Pesce, Dominic W.; Broderick, Avery E.; Wong, George N.; Dhruv, Vedant; Wielgus, Maciek; Gammie, Charles F.; Chan, Chi-Kwan; Chatterjee, Koushik; Emami, Razieh; Mizuno, Yosuke; Gold, Roman; Fromm, Christian M.; Ricarte, Angelo; Yoon, Doosoo; Joshi, Abhishek V.; Prather, Ben; Cruz-Osorio, Alejandro; Johnson, Michael D.; Porth, Oliver; Olivares, Héctor; Younsi, Ziri; Rezzolla, Luciano; Vos, Jesse; Qiu, Richard; Nathanail, Antonios; Narayan, Ramesh; Chael, Andrew; Anantua, Richard; Moscibrodzka, Monika; Akiyama, Kazunori; Alberdi, Antxon; Alef, Walter; Algaba, Juan Carlos; Asada, Keiichi; Azulay, Rebecca; Bach, Uwe; Baczkó, Anne-Kathrin; Ball, David; Baloković, Mislav; Barrett, John; Bauböck, Michi; Benson, Bradford A.; Bintley, Dan; Blackburn, Lindy; Blundell, Raymond; Bouman, Katherine L.; Bower, Geoffrey C.; Boyce, Hope; Bremer, Michael; Brinkerink, Christiaan D.; Brissenden, Roger; Britzen, Silke; Brogiere, Dominique; Bronzwaer, Thomas; Bustamante, Sandra; Byun, Do-Young; Carlstrom, John E.; Ceccobello, Chiara; Chatterjee, Shami; Chen, Ming-Tang; Chen, Yongjun; Cheng, Xiaopeng; Cho, Ilje; Christian, Pierre; Conroy, Nicholas S.; Conway, John E.; Cordes, James M.; Crawford, Thomas M.; Crew, Geoffrey B.; Cui, Yuzhu; Davelaar, Jordy; Laurentis, Mariafelicia De; Deane, Roger; Dempsey, Jessica; Desvignes, Gregory; Dexter, Jason; Doeleman, Sheperd S.; Dougal, Sean; Dzib, Sergio A.; Eatough, Ralph P.; Falcke, Heino; Farah, Joseph; Fish, Vincent L.; Fomalont, Ed; Ford, H. Alyson; Fraga-Encinas, Raquel; Freeman, William T.; Friberg, Per; Fuentes, Antonio; Galison, Peter; García, Roberto; Gentaz, Olivier; Goddi, Ciriaco; Gómez-Ruiz, Arturo I.; Gómez, José L.; Gu, Minfeng; Gurwell, Mark; Hada, Kazuhiro; Haggard, Daryl; Haworth, Kari; Hecht, Michael H.; Hesper, Ronald; Heumann, Dirk; Ho, Luis C.; Ho, Paul; Honma, Mareki; Huang, Chih-Wei L.; Huang, Lei; Hughes, David H.; Ikeda, Shiro; Impellizzeri, C. M. Violette; Inoue, Makoto; Issaoun, Sara; James, David J.; Jannuzi, Buell T.; Janssen, Michael; Jeter, Britton; Jiang, Wu; Jiménez-Rosales, Alejandra; Jorstad, Svetlana; Jung, Taehyun; Karami, Mansour; Karuppusamy, Ramesh; Kawashima, Tomohisa; Keating, Garrett K.; Kettenis, Mark; Kim, Dong-Jin; Kim, Jae-Young; Kim, Jongsoo; Kim, Junhan; Kino, Motoki; Koay, Jun Yi; Kocherlakota, Prashant; Kofuji, Yutaro; Koch, Patrick M.; Koyama, Shoko; Kramer, Carsten; Kramer, Michael; Krichbaum, Thomas P.; Kuo, Cheng-Yu; Bella, Noemi La; Lauer, Tod R.; Lee, Daeyoung; Lee, Sang-Sung; Lehner, Luis; Leung, Po Kin; Levis, Aviad; Li, Zhiyuan; Lico, Rocco; Lindahl, Greg; Lindqvist, Michael; Lisakov, Mikhail; Liu, Jun; Liu, Kuo; Liuzzo, Elisabetta; Lo, Wen-Ping; Lobanov, Andrei P.; Loinard, Laurent; Lonsdale, Colin J.; Lu, Ru-Sen; Mao, Jirong; Marchili, Nicola; Markoff, Sera; Marrone, Daniel P.; Marscher, Alan P.; Martí-Vidal, Iván; Matsushita, Satoki; Matthews, Lynn D.; Menten, Karl M.; Michalik, Daniel; Mizuno, Izumi; Moran, James M.; Moriyama, Kotaro; Müller, Cornelia; Mus, Alejandro; Musoke, Gibwa; Myserlis, Ioannis; Nadsdski, Andrew; Nagai, Hiroshi; Nagar, Neil M.; Nakamura, Masanori; Narayanan, Gopal; Natarajan, Iniyani; Fuentes, Santiago Navarro; Neilsen, Joey; Neri, Roberto; Ni, Chunhong; Noutsos, Aristeidis; Nowak, Michael A.; Oh, Junghwan; Okino, Hiroki; Ortiz-León, Gisela N.; Oyama, Tomoaki; Palumbo, Daniel C. M.; Paraschos, Georgios Filippos; Park, Jongho; Parsons, Harriet; Patel, Nimesh; Pen, Ue-Li; Piéту, Vincent; Plambeck, Richard; Popstefanija, Aleksandar; Pötzl, Felix M.; Preciado-López, Jorge A.; Pu, Hung-Yi; Ramakrishnan, Venkatesh; Rao, Ramprasad; Rawlings, Mark G.; Raymond, Alexander W.; Ripperda, Bart; Roelofs, Freek; Rogers, Alan; Ros, Eduardo; Romero-Cañizales, Cristina; Roshanineshat, Arash; Rottmann, Helge; Roy, Alan L.; Ruiz, Ignacio; Ruszczyk, Chet; Rygl, Kazi L. J.; Sánchez, Salvador; Sánchez-Argüelles, David; Sánchez-Portal, Miguel; Sasada, Mahito; Satapathy, Kaushik; Savolainen, Tuomas; Schloerb, F. Peter; Schonfeld, Jonathan; Schuster, Karl-Friedrich; Shao, Lijing; Shen, Zhiqiang; Small, Des; Sohn, Bong Won; Soohoo, Jason; Soucar, Kamal; Sun, He; Tazaki, Fumie; Tetarenko, Alexandra J.; Tiede, Paul; Tilanus, Remo P. J.; Titus, Michael; Torne, Pablo; Traianou, Efthalia; Trent, Tyler; Trippé, Sascha; Turk, Matthew; Bimmel, Ilse Van; Van Langevelde, Huib Jan; Van Rossum, Daniel R.; Wagner, Jan; Ward-Thompson, Derek; Wardle, John; Weintraub, Jonathan; Wex, Norbert; Wharton, Robert; Wiik, Kaj; Witzel, Gunther; Wondrak, Michael F.; Wu, Qingwen; Yamaguchi, Paul; Young, André; Young, Ken; Yuan, Feng; Yuan, Ye-Fei; Zensus, J. Anton; Zhang, Shuo; Zhao, Guang-Yao; Zhao, Shan-Shan "A Universal Power-law Prescription for Variability from Synthetic Images of Black Hole Accretion Flows," *The Astrophysical Journal*, 930: L20, 2022.
- Gerasimov, Ivan S.; Egorov, Oleg V.; Lozinskaya, Tatiana A.; Moiseev, Alexei V.; Oparin, Dmitry V. "Stellar feedback impact on the ionized gas kinematics in the dwarf galaxy Sextans A," *Monthly Notices of the Royal Astronomical Society*, 517: 4968, 2022.
- Ghasemi-Nodehi, M.; Tabatabaei, Fatemeh S.; Sargent, Mark; Murphy, Eric J.; Khosroshahi, Habib; Beswick, Rob; Bonaldi, Anna; Schinnerer, Eva "Evolution of thermal and nonthermal radio continuum emission on kpc scales-Predictions for SKA," *Monthly Notices of the Royal Astronomical Society*, 515: 1158, 2022.
- Ghosh, Rana; Sil, Milan; Kumar Mondal, Suman; Gorai, Prasanta; Sahu, Dipen; Kumar Kushwaha, Rahul; Sivaraman, Bhalamurugan; Das, Ankan "Phenol in High-mass Star-forming Regions," *Research in Astronomy and Astrophysics*, 22: 065021, 2022.
- Giacintucci, S.; Venturi, T.; Markevitch, M.; Bourdin, H.; Mazzotta, P.; Merluzzi, P.; Dallacasa, D.; Bardelli, S.; Sikhosana, S. P.; Smirnov, O.; Bernardi, G. "A Candle in the Wind: A Radio Filament in the Core of the A3562 Galaxy Cluster," *The Astrophysical Journal*, 934: 49, 2022.
- Giarratana, S.; Rhodes, L.; Marcote, B.; Fender, R.; Ghirlanda, G.; Giroletti, M.;

- Nava, L.; Paredes, J. M.; Rivasio, M. E.; Ribó, M.; Patel, M.; Rastinejad, J.; Schroeder, G.; Fong, W.; Gompertz, B. P.; Levan, A. J.; O'Brien, P. "VLBI observations of GRB 201015A, a relatively faint GRB with a hint of very high-energy gamma-ray emission," *Astronomy and Astrophysics*, 664: A36, 2022.
- Gilli, R.; Norman, C.; Calura, F.; Vito, F.; Decarli, R.; Marchesi, S.; Iwasawa, K.; Comastri, A.; Lanzuisi, G.; Pozzi, F.; D'Amato, Q.; Vignali, C.; Brusa, M.; Mignoli, M.; Cox, P. "Supermassive black holes at high redshift are expected to be obscured by their massive host galaxies' interstellar medium," *Astronomy and Astrophysics*, 666: A17, 2022.
- Giménez-Arteaga, Clara; Brammer, Gabriel B.; Marchesini, Danilo; Colina, Luis; Bajaj, Varun; Brinch, Malte; Calzetti, Daniela; Lange-Vagle, Daniel; Murphy, Eric J.; Perna, Michele; Piqueras-López, Javier; Snyder, Gregory F. "High-resolution Hubble Space Telescope Imaging Survey of Local Star-forming Galaxies. I. Spatially Resolved Obscured Star Formation with Ha and Paschen- $\beta$  Recombination Lines," *The Astrophysical Journal Supplement Series*, 263: 17, 2022.
- Ginolfi, M.; Piconcelli, E.; Zappacosta, L.; Jones, G. C.; Pentericci, L.; Maiolino, R.; Travascio, A.; Mencì, N.; Carniani, S.; Rizzo, F.; Arrigoni Battaia, F.; Cantalupo, S.; De Breuck, C.; Graziani, L.; Knudsen, K.; Laursen, P.; Mainieri, V.; Schneider, R.; Stanley, F.; Valiante, R.; Verhamme, A. "Detection of companion galaxies around hot dust-obscured hyper-luminous galaxy W0410-0913," *Nature Communications*, 13: 4574, 2022.
- Ginsburg, A.; Csengeri, T.; Galván-Madrid, R.; Cunningham, N.; Álvarez-Gutiérrez, R. H.; Baug, T.; Bonfand, M.; Bontemps, S.; Busquet, G.; Díaz-González, D. J.; Fernández-López, M.; Guzmán, A.; Herpin, F.; Liu, H.; López-Sepulcre, A.; Louvet, F.; Maud, L.; Motte, F.; Nakamura, F.; Nony, T.; Olguin, F. A.; Pouteau, Y.; Sanhueza, P.; Stutz, A. M.; Towner, A. P. M.; Alma-Imf Consortium; Armante, M.; Battersby, C.; Bronfman, L.; Braine, J.; Brouillet, N.; Chapillon, E.; Di Francesco, J.; Gusdorf, A.; Izumi, N.; Joncour, I.; Walker Lu, X.; Men'Shchikov, A.; Menten, K. M.; Moraux, E.; Molet, J.; Mundy, L.; Nguyen Luong, Q.; Reyes-Reyes, S. D.; Robitaille, J.; Rosolowsky, E.; Sandoval-Garrido, N. A.; Svoboda, B.; Tatematsu, K.; Walker, D. L.; Whitworth, A.; Wu, B.; Wyrowski, F. "ALMA-IMF. II. Investigating the origin of stellar masses: Continuum images and data processing," *Astronomy and Astrophysics*, 662: A9, 2022.
- Girdhar, A.; Harrison, C. M.; Mainieri, V.; Bittner, A.; Costa, T.; Kharb, P.; Mukherjee, D.; Arrigoni Battaia, F.; Alexander, D. M.; Calistro Rivera, G.; Circosta, C.; De Breuck, C.; Edge, A. C.; Farina, E. P.; Kakkad, D.; Lansbury, G. B.; Molyneux, S. J.; Mullaney, J. R.; S. Silpa; Thomson, A. P.; Ward, S. R. "Quasar feedback survey: multiphase outflows, turbulence, and evidence for feedback caused by low power radio jets inclined into the galaxy disc," *Monthly Notices of the Royal Astronomical Society*, 512: 1608, 2022.
- Giulietti, M.; Massardi, M.; Lapi, A.; Bonato, M.; Enia, A. F. M.; Negrello, M.; D'Amato, Q.; Behiri, M.; De Zotti, G. "The far-infrared/radio correlation for a sample of strongly lensed dusty star-forming galaxies detected by Herschel," *Monthly Notices of the Royal Astronomical Society*, 511: 1408, 2022.
- Glass, David H. W.; Sansom, Anne E.; Davis, Timothy A.; Popescu, Cristina C. "Cool interstellar medium as an evolutionary tracer in ALMA-observed local dusty early-type galaxies," *Monthly Notices of the Royal Astronomical Society*, 517: 5524, 2022.
- Glikman, E.; Lacy, M.; Lamassa, S.; Bradley, C.; Djorgovski, S. G.; Urrutia, T.; Gates, E. L.; Graham, M. J.; Urry, M.; Yoon, I. "The WISE-2MASS Survey: Red Quasars Into the Radio Quiet Regime," *The Astrophysical Journal*, 934: 119, 2022.
- Gloudeans, A. J.; Duncan, K. J.; Saxena, A.; Harikane, Y.; Hill, G. J.; Zeimann, G. R.; Röttgering, H. J. A.; Yang, D.; Best, P. N.; Bañados, E.; Drabant, A.; Hardcastle, M. J.; Hennawi, J. F.; Lansbury, G.; Magliocchetti, M.; Miley, G. K.; Nanni, R.; Shimwell, T. W.; Smith, D. J. B.; Venemans, B. P.; Wagenveld, J. D. "Discovery of 24 radio-bright quasars at  $4.9 \leq z \leq 6.6$  using low-frequency radio observations," *Astronomy and Astrophysics*, 668: A27, 2022.
- Glowacki, Marcin; Collier, Jordan D.; Kazemi-Moridani, Amir; Frank, Bradley; Roberts, Hayley; Darling, Jeremy; Klöckner, Hans-Rainer; Adams, Nathan; Baker, Andrew J.; Bershad, Matthew; Blecher, Tariq; Blyth, Sarah-Louise; Bowler, Rebecca; Catinella, Barbara; Chemin, Laurent; Crawford, Steven M.; Cress, Catherine; Davé, Romeel; Deane, Roger; De Blok, Erwin; Delhaize, Jacinta; Duncan, Kenneth; Elson, Ed; February, Sean; Gawiser, Eric; Hatfield, Peter; Healy, Julia; Henning, Patricia; Hess, Kelley M.; Heywood, Ian; Holwerda, Benne W.; Hoosain, Munira; Hughes, John P.; Hutchens, Zackary L.; Jarvis, Matt; Kannappan, Sheila; Katz, Neal; Kereš, Dušan; Korsaga, Marie; Kraan-Korteweg, Renée C.; Lah, Philip; Lochner, Michelle; Maddox, Natasha; Makhathini, Sphesihle; Meurer, Gerhardt R.; Meyer, Martin; Obreschkow, Danail; Oh, Se-Heon; Oosterloo, Tom; Oppor, Joshua; Pan, Hengxing; Pisano, D. J.; Randriamiarinarivo, Nandrianina; Ravindranath, Swara; Schröder, Anja C.; Skelton, Rosalind; Smirnov, Oleg; Smith, Mathew; Somerville, Rachel S.; Srikanand, Raghunathan; Staveley-Smith, Lister; Tanaka, Masayuki; Vaccari, Mattia; Van Driel, Wim; Verheijen, Marc; Walter, Fabian; Wu, John F.; Zwaan, Martin A. "Looking at the Distant Universe with the MeerKAT Array: Discovery of a Luminous OH Megamaser at  $z > 0.5$ ," *The Astrophysical Journal*, 931: L7, 2022.
- Gobat, R.; D'Eugenio, C.; Liu, D.; Caminha, G. B.; Daddi, E.; Blázquez, D. "The uncertain interstellar medium of high-redshift quiescent galaxies: Impact of methodology," *Astronomy and Astrophysics*, 668: L4, 2022.
- Gómez, José L.; Traianou, Efthalia; Krichbaum, Thomas P.; Lobanov, Andrei P.; Fuentes, Antonio; Lico, Rocco; Zhao, Guang-Yao; Bruni, Gabriele; Kovalev, Yuri Y.; Lähteenmäki, Anne; Voitsik, Petr A.; Lisakov, Mikhail M.; Angelakis, Emmanouil; Bach, Uwe; Casadio, Carolina; Cho, Ilje; Dey, Lankeswar; Gopakumar, Achamveedu; Gurvits, Leonid I.; Jorstad, Svetlana; Kovalev, Yuri A.; Lister, Matthew L.; Marscher, Alan P.; Myserlis, Ioannis; Pushkarev, Alexander B.; Ros, Eduardo; Savolainen, Tuomas; Tornikoski, Merja; Valtonen, Mauri J.; Zensus, Anton "Probing the Innermost Regions of AGN Jets and Their Magnetic Fields with RadioAstron. V. Space and Ground Millimeter-VLBI Imaging of OJ 287," *The Astrophysical Journal*, 924: 122, 2022.
- Gómez-Guijarro, C.; Elbaz, D.; Xiao, M.; Béthermin, M.; Franco, M.; Magnelli, B.; Daddi, E.; Dickinson, M.; Demarco, R.; Inami, H.; Rujopakarn, W.; Magdis, G. E.; Shu, X.; Chary, R.; Zhou, L.; Alexander, D. M.; Bournaud, F.; Ciesla, L.; Ferguson, H. C.; Finkelstein, S. L.; Giavalisco, M.; Iono, D.; Juneau, S.; Kartaltepe, J. S.; Lagache, G.; Le Floc'H, E.; Leiton, R.; Lin, L.; Motohara, K.; Mullaney, J.; Okumura, K.; Pannella, M.; Papovich, C.; Pope, A.; Sargent, M. T.; Silverman, J. D.; Treister, E.; Wang, T. "GOODS-ALMA 2.0: Source catalog, number counts, and prevailing compact sizes in 1.1 mm galaxies," *Astronomy and Astrophysics*, 658: A43, 2022.
- Gómez-Guijarro, C.; Elbaz, D.; Xiao, M.; Kokorev, V. I.; Magdis, G. E.; Magnelli, B.; Daddi, E.; Valentino, F.; Sargent, M. T.; Dickinson, M.; Béthermin, M.; Franco, M.; Pope, A.; Kalita, B. S.; Ciesla, L.; Demarco, R.; Inami, H.; Rujopakarn, W.; Shu, X.; Wang, T.; Zhou, L.; Alexander, D. M.; Bournaud, F.; Chary, R.; Ferguson, H. C.; Finkelstein, S. L.; Giavalisco, M.; Iono, D.; Juneau, S.; Kartaltepe, J. S.; Lagache, G.; Le Floc'H, E.; Leiton, R.; Leroy, L.; Lin, L.; Motohara, K.; Mullaney, J.; Okumura, K.; Pannella, M.; Papovich, C.; Treister, E. "GOODS-ALMA 2.0: Starbursts in the main sequence reveal compact star formation regulating galaxy evolution prequenching," *Astronomy and Astrophysics*, 659: A196, 2022.
- Gong, Hang "Discovery of a Compact X-Ray Object with a 614 s Periodicity in the Direction of the Galactic Center," *The Astrophysical Journal*, 933: 240, 2022.
- Goodwin, A. J.; Van Velzen, S.; Miller-Jones, J. C. A.; Mummery, A.; Bietenholz, M. F.; Wederfoot, A.; Hammerstein, E.; Bonnerot, C.; Hoffmann, J.; Yan, L. "AT2019azh: an unusually long-lived, radio-bright thermal tidal disruption event," *Monthly Notices of the Royal Astronomical Society*, 511: 5328, 2022.
- Gopal Krishna; Dabhade, Pratik "X-shaped radio galaxy 3C 223.1: A 'double boomerang' with an anomalous spectral gradient," *Astronomy and Astrophysics*, 663: L8, 2022.
- Gottlieb, C. A.; Decin, L.; Richards, A. M. S.; De Ceuster, F.; Homan, W.

## APPENDIX A: PUBLICATIONS

- Wallström, S. H. J.; Danilovich, T.; Millar, T. J.; Montargès, M.; Wong, K. T.; McDonald, I.; Baudry, A.; Bolte, J.; Cannon, E.; De Beck, E.; De Koter, A.; El Mellah, I.; Etoke, S.; Gobrecht, D.; Gray, M.; Herpin, F.; Jeste, M.; Kervella, P.; Khouri, T.; Lagadec, E.; Maes, S.; Malfait, J.; Menten, K. M.; Müller, H. S. P.; Pimpanuwat, B.; Plane, J. M. C.; Sahai, R.; Van De Sande, M.; Waters, L. B. F. M.; Yates, J.; Zijlstra, A. "ATOMIUM: ALMA tracing the origins of molecules in dust forming oxygen rich M-type stars. Motivation, sample, calibration, and initial results," *Astronomy and Astrophysics*, 660: A94, 2022.
- Greaves, Jane S.; Mason, Brian "Single-dish 1 cm-band radio photometry of protoplanetary discs: few centimetre-sized dust grains?," *Monthly Notices of the Royal Astronomical Society*, 513: 3180-3190, 2022.
- Greaves, Jane S.; Rimmer, Paul B.; Richards, Anita M. S.; Petkowski, Janusz J.; Bains, William; Ranjan, Sukrit; Seager, Sara; Clements, David L.; Silva, Clara Sousa; Fraser, Helen J. "Low levels of sulphur dioxide contamination of Venusian phosphine spectra," *Monthly Notices of the Royal Astronomical Society*, 514: 2994, 2022.
- Groeneveld, C.; Van Weeren, R. J.; Miley, G. K.; Morabito, L. K.; De Gasperin, F.; Callingham, J. R.; Sweijs, F.; Brügger, M.; Botteon, A.; Offringa, A.; Brunetti, G.; Moldon, J.; Bondi, M.; Kappes, A.; Röttgering, H. J. A. "Pushing sub-arcsecond resolution imaging down to 30 MHz with the trans-European International LOFAR Telescope," *Astronomy and Astrophysics*, 658: A9, 2022.
- Grossová, Romana; Werner, Norbert; Massaro, Francesco; Lakhchaura, Kiran; Pišek, Tomáš; Gabányi, Krisztina; Rajpurohit, Kamlesh; Canning, Rebecca E. A.; Nulsen, Paul; O'Sullivan, Ewan; Allen, Steven W.; Fabian, Andrew "Very Large Array Radio Study of a Sample of Nearby X-Ray and Optically Bright Early-type Galaxies," *The Astrophysical Journal Supplement Series*, 258: 30, 2022.
- Guevara Gómez, Juan Camilo; Jafarzadeh, Shahin; Wedemeyer, Sven; Szydlarski, Mikolaj "Propagation of transverse waves in the solar chromosphere probed at different heights with ALMA sub-bands," *Astronomy and Astrophysics*, 665: L2, 2022.
- Guidi, G.; Isella, A.; Testi, L.; Chandler, C. J.; Liu, H. B.; Schmid, H. M.; Rosotti, G.; Meng, C.; Jennings, J.; Williams, J. P.; Carpenter, J. M.; De Gregorio-Monsalvo, I.; Li, H.; Liu, S. F.; Ortolani, S.; Quanz, S. P.; Ricci, L.; Tazzari, M. "Distribution of solids in the rings of the HD 163296 disk: a multiwavelength study★," *Astronomy and Astrophysics*, 664: A137, 2022.
- Gültekin, Kayhan; Nyland, Kristina; Gray, Nichole; Fehmer, Greg; Huang, Tianchi; Sparkman, Matthew; Reines, Amy E.; Greene, Jenny E.; Cackett, Edward M.; Baldassare, Vivienne "Intermediate-mass black holes and the Fundamental Plane of black hole accretion," *Monthly Notices of the Royal Astronomical Society*, 516: 6123, 2022.
- Gupta, N.; Shukla, G.; Srianand, R.; Krogager, J.-K.; Noterdaeme, P.; Baker, A. J.; Combes, F.; Fynbo, J. P. U.; Momjian, E.; Hilton, M.; Hussain, T.; Moodley, K.; Petitjean, P.; Chen, H.-W.; Deka, P.; Dutta, R.; Jose, J.; Józsa, G. I. G.; Kaski, C.; Klöckner, H.-R.; Knowles, K.; Sikhosana, S.; Wagenveld, J. "MALS SALT-NOT Survey of MIR-selected Powerful Radio-bright AGN at  $0 < z < 3.5$ ," *The Astrophysical Journal*, 929: 108, 2022.
- Gupta, N.; Srianand, R.; Momjian, E.; Shukla, G.; Combes, F.; Krogager, J.-K.; Noterdaeme, P.; Petitjean, P. "H I Gas Playing Hide-and-seek around a Powerful FRI-type Quasar at  $z \approx 2.1$ ," *The Astrophysical Journal*, 927: L24, 2022.
- Gururajan, G.; Béthermin, M.; Theulé, P.; Spilker, J. S.; Aravena, M.; Archipley, M. A.; Chapman, S. C.; De Breuck, C.; Gonzalez, A.; Hayward, C. C.; Hezaveh, Y.; Hill, R.; Jarugula, S.; Litke, K. C.; Malkan, M.; Marrone, D. P.; Narayanan, D.; Phadke, K. A.; Reuter, C.; Vieira, J. D.; Vizgan, D.; Weiß, A. "High resolution spectral imaging of CO(7-6), [CII](2-1), and continuum of three high-z lensed dusty star-forming galaxies using ALMA," *Astronomy and Astrophysics*, 663: A22, 2022.
- Guzmán Ccolque, Estrella; Fernández-López, Manuel; Zapata, Luis A.; Baug, Tapas "Possible Explosive Dispersal Outflow in IRAS 16076-5134 Revealed with ALMA," *The Astrophysical Journal*, 937: 51, 2022.
- Haasler, D.; Rivilla, V. M.; Martín, S.; Holdship, J.; Viti, S.; Harada, N.; Mangum, J.; Sakamoto, K.; Muller, S.; Tanaka, K.; Yoshimura, Y.; Nakanishi, K.; Colzi, L.; Hunt, L.; Emig, K. L.; Aladro, R.; Humire, P.; Henkel, C.; Van Der Werf, P. "First extragalactic detection of a phosphorus-bearing molecule with ALCHEMI: Phosphorus nitride (PN)," *Astronomy and Astrophysics*, 659: A158, 2022.
- Hajela, A.; Margutti, R.; Bright, J. S.; Alexander, K. D.; Metzger, B. D.; Nedora, V.; Kathirgamaraju, A.; Margalit, B.; Radice, D.; Guidorzi, C.; Berger, E.; Macfadyen, A.; Giannios, D.; Chornock, R.; Heywood, I.; Sironi, L.; Gottlieb, O.; Coppejans, D.; Laskar, T.; Cendes, Y.; Duran, R. Barniol; Eftekhari, T.; Fong, W.; McDowell, A.; Nicholl, M.; Xie, X.; Zrake, J.; Bernuzzi, S.; Broekgaarden, F. S.; Kilpatrick, C. D.; Terreran, G.; Villar, V. A.; Blanchard, P. K.; Gomez, S.; Hosseinzadeh, G.; Matthews, D. J.; Rastinejad, J. C. "Evidence for X-Ray Emission in Excess to the Jet-afterglow Decay 3.5 yr after the Binary Neutron Star Merger GW 170817: A New Emission Component," *The Astrophysical Journal*, 927: L17, 2022.
- Hales, Antonio S.; Marino, Sebastián; Sheehan, Patrick D.; Ulloa, Silvio; Pérez, Sebastián; Matrà, Luca; Kral, Quentin; Wyatt, Mark; Dent, William; Carpenter, John "ALMA Observations of the HD 110058 Debris Disk," *The Astrophysical Journal*, 940: 161, 2022.
- Harada, Nanase; Martín, Sergio; Mangum, Jeffrey G.; Sakamoto, Kazushi; Muller, Sebastien; Rivilla, Víctor M.; Henkel, Christian; Meier, David S.; Colzi, Laura; Yamagishi, Mitsuyoshi; Tanaka, Kunihiko; Nakanishi, Kouichiro; Herrero-Illana, Rubén; Yoshimura, Yuki; Humire, P. K.; Aladro, Rebeca; Van Der Werf, Paul P.; Emig, Kimberly L. "ALCHEMI Finds a "Shocking" Carbon Footprint in the Starburst Galaxy NGC 253," *The Astrophysical Journal*, 938: 80, 2022.
- Harikane, Yuichi; Inoue, Akio K.; Mawatari, Ken; Hashimoto, Takuya; Yamanaka, Satoshi; Fudamoto, Yoshinobu; Matsuo, Hiroshi; Tamura, Yoichi; Dayal, Pratika; Yung, L. Y. Aaron; Hutter, Anne; Pacucci, Fabio; Sugahara, Yuma; Koekemoer, Anton M. "A Search for H-Dropout Lyman Break Galaxies at  $z \approx 12$ ," *The Astrophysical Journal*, 929: 1, 2022.
- Hartigan, Patrick; Hummel, Maxwell; Isella, Andrea; Downes, Turlough "ALMA Data Cubes and Continuum Maps of the Irradiated Western Wall in Carina," *The Astronomical Journal*, 164: 257, 2022.
- Hashimoto, Jun; Liu, Haoyu Baobab; Dong, Ruobing; Liu, Beibei; Muto, Takayuki "Grain Growth in the Dust Ring with a Crescent around the Very Low-mass Star ZZ Tau IRS with JVLA," *The Astrophysical Journal*, 941: 66, 2022.
- Hatsukade, Bunyo; Hashimoto, Tetsuya; Niino, Yuu; Hsu, Tzu-Yin "Diverse Properties of Molecular Gas in the Host Galaxies of Fast Radio Bursts," *The Astrophysical Journal*, 940: L34, 2022.
- Hayakawa, Ryota; Yamada, Shinya; Suda, Hirotake; Ichinohe, Yuto; Higurashi, Ryota; Sakemi, Haruka; Machida, Mami; Ohmura, Takumi; Katsuda, Satoru; Uchiyama, Hideki; Sato, Toshiki; Akamatsu, Hiroki; Axelsson, Magnus "X-ray hot spots in the eastern ear of the supernova remnant W 50 and the microquasar SS 433 system," *Publications of the Astronomical Society of Japan*, 74: 510, 2022.
- Hazboun, Jeffrey S.; Crump, Jack; Lommen, Andrea N.; Montano, Sergio; Berry, Samantha J. H.; Zeldes, Jesse; Teng, Elizabeth; Ray, Paul S.; Kerr, Matthew; Arzoumanian, Zaven; Bogdanov, Slavko; Deneva, Julia; Lewandowska, Natalia; Markwardt, Craig B.; Ransom, Scott; Enoto, Teruaki; Wood, Kent S.; Gendreau, Keith C.; Howe, David A.; Parthasarathy, Aditya "A Detection of Red Noise in PSR J1824-2452A and Projections for PSR B1937+21 Using NICER X-Ray Timing Data," *The Astrophysical Journal*, 928: 67, 2022.
- Hazboun, Jeffrey S.; Simon, Joseph; Madison, Dustin R.; Arzoumanian, Zaven; Cromartie, H. Thankful; Crowter, Kathryn; Decesar, Megan E.; Demorest, Paul B.; Dolch, Timothy; Ellis, Justin A.; Ferdman, Robert D.; Ferrara, Elizabeth C.; Fonseca, Emmanuel; Gentile, Peter A.; Jones, Glenn; Jones, Megan L.; Lam, Michael T.; Levin, Lina; Lorimer, Duncan R.; Lynch, Ryan S.; McLaughlin, Maura A.; Ng, Cherry; Nice, David J.; Pennucci, Timothy T.; Ransom, Scott M.; Ray, Paul S.; Spiewak, Renée; Stairs, Ingrid H.; Stovall, Kevin; Swiggum, Joseph K.; Zhu, Weiwei; The

- Nanograv Collaboration "Bayesian Solar Wind Modeling with Pulsar Timing Arrays," *The Astrophysical Journal*, 929: 39, 2022.
- He, Hao; Wilson, Christine; Brunetti, Nathan; Finn, Molly; Bemis, Ashley; Johnson, Kelsey "Embedded Young Massive Star Clusters in the Antennae Merger," *The Astrophysical Journal*, 928: 57, 2022.
- He, Jiao; Simons, Mart; Fedoseev, Gleb; Chuang, Ko-Ju; Qasim, Danna; Lamberts, Thanja; Ioppolo, Sergio; Mcguire, Brett A.; Cuppen, Herma; Linnartz, Harold "Methoxymethanol formation starting from CO hydrogenation," *Astronomy and Astrophysics*, 659: A65, 2022.
- Heald, G. H.; Heesen, V.; Sridhar, S. S.; Beck, R.; Bomans, D. J.; Brüggem, M.; Chyży, K. T.; Damas-Segovia, A.; Dettmar, R.-J.; English, J.; Henriksen, R.; Ideguchi, S.; Irwin, J.; Krause, M.; Li, J.-T.; Murphy, E. J.; Nikiel-Wroczyński, B.; Piotrowska, J.; Rand, R. J.; Shimwell, T.; Stein, Y.; Vargas, C. J.; Wang, Q. D.; Van Weeren, R. J.; Wiegert, T. "CHANG-ES XXIII: Influence of a galactic wind in NGC 5775," *Monthly Notices of the Royal Astronomical Society*, 509: 658-684, 2022.
- Heesen, V.; Staffehl, M.; Basu, A.; Beck, R.; Stein, M.; Tabatabaei, F. S.; Hardcastle, M. J.; Chyży, K. T.; Shimwell, T. W.; Adebahr, B.; Beswick, R.; Bomans, D. J.; Botteon, A.; Brinks, E.; Brüggem, M.; Dettmar, R.-J.; Drabent, A.; De Gasperin, F.; Gürkan, G.; Heald, G. H.; Horellou, C.; Nikiel-Wroczyński, B.; Paladino, R.; Piotrowska, J.; Röttgering, H. J. A.; Smith, D. J. B.; Tasse, C. "Nearby galaxies in the LOFAR Two-metre Sky Survey. I. Insights into the non-linearity of the radio-SFR relation," *Astronomy and Astrophysics*, 664: A83, 2022.
- Heimsoth, Daniel J.; Stephens, Ian W.; Arce, Héctor G.; Bourke, Tyler L.; Myers, Philip C.; Dunham, Michael M. "Evolution and Kinematics of Protostellar Envelopes in the Perseus Molecular Cloud," *The Astrophysical Journal*, 927: 88, 2022.
- Heintz, K. E.; Oesch, P. A.; Aravena, M.; Bouwens, R. J.; Dayal, P.; Ferrara, A.; Fudamoto, Y.; Graziani, L.; Inami, H.; Sommovigo, L.; Smit, R.; Stefanon, M.; Topping, M.; Pallottini, A.; Van Der Werf, P. "The ALMA REBELS Survey: The Cosmic H I Gas Mass Density in Galaxies at  $z \approx 7$ ," *The Astrophysical Journal*, 934: L27, 2022.
- Heinzel, Petr; Berlicki, Arkadiusz; Bárta, Miroslav; Rudawy, Paweł; Gunár, Stanislav; Labrosse, Nicolas; Radziszewski, Krzysztof "ALMA as a Prominence Thermometer: First Observations," *The Astrophysical Journal*, 927: L29, 2022.
- Henriques, Vasco M. J.; Jafarzadeh, Shahin; Guevara Gómez, Juan Camilo; Eklund, Henrik; Wedemeyer, Sven; Szydlarski, Mikołaj; Haugan, Stein Vidar H.; Mohan, Atul "The Solar ALMA Science Archive (SALSA). First release, SALAT, and FITS header standard," *Astronomy and Astrophysics*, 659: A31, 2022.
- Henshaw, Jonathan D.; Krumholz, Mark R.; Butterfield, Natalie O.; Mackey, Jonathan; Ginsburg, Adam; Haworth, Thomas J.; Noguera-Lara, Francisco; Barnes, Ashley T.; Longmore, Steven N.; Bally, John; Kruijssen, J. M. Diederik; Mills, Elisabeth A. C.; Beuther, Henrik; Walker, Daniel L.; Battersby, Cara; Bulatek, Alyssa; Henning, Thomas; Ott, Juergen; Soler, Juan D. "A wind-blown bubble in the Central Molecular Zone cloud G0.253+0.016," *Monthly Notices of the Royal Astronomical Society*, 509: 4758, 2022.
- Hewitt, D. M.; Snelders, M. P.; Hessels, J. W. T.; Nimmo, K.; Jahns, J. N.; Spitler, L. G.; Gourdji, K.; Hilmarsson, G. H.; Michilli, D.; Ould-Boukattine, O. S.; Scholz, P.; Seymour, A. D. "Arecibo observations of a burst storm from FRB 20121102A in 2016," *Monthly Notices of the Royal Astronomical Society*, 515: 3577, 2022.
- Heyer, Mark; Gregg, Benjamin; Calzetti, Daniela; Elmegreen, Bruce G.; Kennicutt, Robert; Adamo, Angela; Evans, Aaron S.; Grasha, Kathryn; Lowenthal, James D.; Narayanan, Gopal; Rosa-Gonzalez, Daniel; Schloerb, F. P.; Souccar, Kamal; Tang, Yuping; Teuben, Peter; Vega, Olga; Wall, William F.; Yun, Min S. "The Dense Gas Mass Fraction and the Relationship to Star Formation in M51," *The Astrophysical Journal*, 930: 170, 2022.
- Heywood, I.; Jarvis, M. J.; Hale, C. L.; Whittam, I. H.; Bester, H. L.; Hugo, B.; Kenyon, J. S.; Prescott, M.; Smirnov, O. M.; Tasse, C.; Afonso, J. M.; Best, P. N.; Collier, J. D.; Deane, R. P.; Frank, B. S.; Hardcastle, M. J.; Knowles, K.; Maddox, N.; Murphy, E. J.; Prandoni, I.; Randriamampandry, S. M.; Santos, M. G.; Sekhar, S.; Tabatabaei, F.; Taylor, A. R.; Thorat, K. "MIGHTEE: Total intensity radio continuum imaging and the COSMOS / XMM-LSS Early Science fields," *Monthly Notices of the Royal Astronomical Society*, 2110: , 2022.
- Heywood, I.; Rammala, I.; Camilo, F.; Cotton, W. D.; Yusef-Zadeh, F.; Abbott, T. D.; Adam, R. M.; Adams, G.; Aldera, M. A.; Asad, K. M. B.; Bauermeister, E. F.; Bennett, T. G. H.; Bester, H. L.; Bode, W. A.; Botha, D. H.; Botha, A. G.; Brederode, L. R. S.; Buchner, S.; Burger, J. P.; Cheetham, T.; De Villiers, D. I. L.; Dikgale-Mahlakoana, M. A.; Du Toit, L. J.; Esterhuysen, S. W. P.; Fanaroff, B. L.; February, S.; Fourie, D. J.; Frank, B. S.; Gamatham, R. R. G.; Geyer, M.; Goedhart, S.; Gouws, M.; Gumede, S. C.; Hlakola, M. J.; Hokwana, A.; Hoosen, S. W.; Horrell, J. M. G.; Hugo, B.; Isaacson, A. I.; Józsa, G. I. G.; Jonas, J. L.; Joubert, A. F.; Julie, R. P. M.; Kapp, F. B.; Kenyon, J. S.; Kotzé, P. P. A.; Kriek, N.; Kriel, H.; Krishnan, V. K.; Lehmensiek, R.; Liebenberg, D.; Lord, R. T.; Lunsky, B. M.; Madisa, K.; Magnus, L. G.; Mahgoub, O.; Makhaba, A.; Makhathini, S.; Malan, J. A.; Manley, J. R.; Marais, S. J.; Martens, A.; Mauch, T.; Merry, B. C.; Millenaar, R. P.; Mnyandu, N.; Mokone, O. J.; Monama, T. E.; Mphogo, M. C.; New, W. S.; Ngcebetsha, B.; Ngoashe, K. J.; Ockards, M. T.; Oozeer, N.; Otto, A. J.; Passmore, S. S.; Patel, A. A.; Peens-Hough, A.; Perkins, S. J.; Ramaila, A. J. T.; Ramanujam, N. M. R.; Ramudzuli, Z. R.; Ratcliffe, S. M.; Robynjtjes, A.; Salie, S.; Sambu, N.; Schollar, C. T. G.; Schwardt, L. C.; Schwartz, R. L.; Serylak, M.; Siebrits, R.; Sirothia, S. K.; Slabber, M.; Smirnov, O. M.; Sofeya, L.; Taljaard, B.; Tasse, C.; Tiplady, A. J.; Toruvanda, O.; Twum, S. N.; Van Balla, T. J.; Van Der Byl, A.; Van Der Merwe, C.; Van Tonder, V.; Van Wyk, R.; Venter, A. J.; Venter, M.; Wallace, B. H.; Welz, M. G.; Williams, L. P.; Xia, B. "The 1.28 GHz MeerKAT Galactic Center Mosaic," *The Astrophysical Journal*, 925: 165, 2022.
- Hill, Ryley; Chapman, Scott; Phadke, Kedar A.; Aravena, Manuel; Archipley, Melanie; Ashby, Matthew L. N.; Béthermin, Matthieu; Canning, Rebecca E. A.; Gonzalez, Anthony; Greve, Thomas R.; Gururajan, Gayathri; Hayward, Christopher C.; Hezaveh, Yashar; Jarugula, Sreevani; Macintyre, Duncan; Marrone, Daniel P.; Miller, Tim; Rennehan, Douglas; Reuter, Cassie; Rotermund, Kaja M.; Scott, Douglas; Spilker, Justin; Vieira, Joaquin D.; Wang, George; Weiß, Axel "Rapid build-up of the stellar content in the protocluster core SPT2349-56 at  $z = 4.3$ ," *Monthly Notices of the Royal Astronomical Society*, 512: 4352, 2022.
- Hincks, Adam D.; Radiconi, Federico; Romero, Charles; Madhavacheril, Mathew S.; Mroczkowski, Tony; Austermann, Jason E.; Barbavara, Eleonora; Battaglia, Nicholas; Battistelli, Elia; Bond, J. Richard; Calabrese, Erminia; De Bernardis, Paolo; Devlin, Mark J.; Dicker, Simon R.; Duff, Shannon M.; Duivenvoorden, Adriaan J.; Dunkley, Jo; Dünner, Rolando; Gallardo, Patricio A.; Govoni, Federica; Hill, J. Colin; Hilton, Matt; Hubmayr, Johannes; Hughes, John P.; Lamagna, Luca; Lokken, Martine; Masi, Silvia; Mason, Brian S.; McMahon, Jeff; Moodley, Kavilan; Murgia, Matteo; Naess, Sigurd; Page, Lyman; Piacentini, Francesco; Salatino, Maria; Sarazin, Craig L.; Schillaci, Alessandro; Sievers, Jonathan L.; Sifón, Cristóbal; Staggs, Suzanne; Ullom, Joel N.; Vacca, Valentina; Van Engelen, Alexander; Vissers, Michael R.; Wollack, Edward J.; Xu, Zhilei "A high-resolution view of the filament of gas between Abell 399 and Abell 401 from the Atacama Cosmology Telescope and MUSTANG-2," *Monthly Notices of the Royal Astronomical Society*, 210: 3335, 2022.
- Hirota, Tomoya; Wolak, Paweł; Hunter, Todd R.; Brogan, Crystal L.; Bartkiewicz, Anna; Durjasz, Michal; Kobak, Agnieszka; Olech, Mateusz; Szymczak, Marian; Burns, Ross A.; Aberfelds, Artis; Baek, Giseon; Brand, Jan; Breen, Shari; Byun, Do-Young; Caratti O Garatti, Alessio; Chen, Xi; Chibueze, James O.; Cyganowski, Claudia; Eislöffel, Jochen; Ellingsen, Simon; Hirano, Naomi; Hu, Bo; Kang, Ji-Hyun; Kim, Jeong-Sook; Kim, Jung-ha; Kim, Kee-Tae; Kim, Mi Kyoung; Kramer, Busaba; Lee, Jeong-Eun; Linz, Hendrik; Liu, Tie; Macleod, Gordon; Mccarthy, Tiede P.; Menten, Karl; Motogi, Kazuhito; Oh, Chung-Sik; Orosz, Gabor; Sobolev, Andrey M.; Stecklum, Bringfried; Sugiyama, Koichiro; Sunada,

## APPENDIX A: PUBLICATIONS

- Kazuyoshi; Uscanga, Lucero; Van Den Heever, Fanie; Volvach, Alexander E.; Volvach, Larisa N.; Wu, Yuan Wei; Yonekura, Yoshinori "Millimeter methanol emission in the high-mass young stellar object G24.33+0.14," *Publications of the Astronomical Society of Japan*, 74: 1234, 2022.
- Ho, Anna Y. Q.; Margalit, Ben; Bremer, Michael; Perley, Daniel A.; Yao, Yuhan; Dobie, Dougal; Kaplan, David L.; O'Brien, Andrew; Petitpas, Glen; Zic, Andrew "Luminous Millimeter, Radio, and X-Ray Emission from ZTF 20acigmel (AT 2020xnd)," *The Astrophysical Journal*, 932: 116, 2022.
- Ho, Anna Y. Q.; Perley, Daniel A.; Yao, Yuhan; Svinkin, Dmitry; De Ugarte Postigo, A.; Perley, R. A.; Kann, D. Alexander; Burns, Eric; Andreoni, Igor; Bellm, Eric C.; Bissaldi, Elisabetta; Bloom, Joshua S.; Brink, Thomas G.; Dekany, Richard; Drake, Andrew J.; Agüí Fernández, José Feliciano; Filippenko, Alexei V.; Frederiks, Dmitry; Graham, Matthew J.; Hristov, Boyan A.; Kasliwal, Mansi M.; Kulkarni, S. R.; Kumar, Harsh; Laher, Russ R.; Lysenko, Alexandra L.; Mailyan, Bagrat; Malacaria, Christian; Miller, A. A.; Poolakkil, S.; Riddle, Reed; Ridnaia, Anna; Rusholme, Ben; Savchenko, Volodymyr; Sollerman, Jesper; Thöne, Christina; Tsvetkova, Anastasia; Ulanov, Mikhail; Von Kienlin, Andreas "Cosmological Fast Optical Transients with the Zwicky Transient Facility: A Search for Dirty Fireballs," *The Astrophysical Journal*, 938: 85, 2022.
- Hoai, D. T.; Nhung, P. T.; Darriulat, P.; Diep, P. N.; Ngoc, N. B.; Thai, T. T.; Tuan-Anh, P. "Morpho-kinematics of the wind of asymptotic giant branch star L2 Pup," *Monthly Notices of the Royal Astronomical Society*, 510: 2363, 2022.
- Hofmann, Ryan A.; Reardon, Kevin P.; Milic, Ivan; Molnar, Momchil E.; Chai, Yi; Uitenbroek, Han "Evaluating Non-LTE Spectral Inversions with ALMA and IBIS," *The Astrophysical Journal*, 933: 244, 2022.
- Hogan, L.; Rigopoulou, D.; García-Burillo, S.; Alonso-Herrero, A.; Barrufet, L.; Combes, F.; García-Berete, I.; Magdis, G. E.; Pereira-Santaella, M.; Thatte, N.; Weiß, A. "Unveiling the main sequence to starburst transition region with a sample of intermediate redshift luminous infrared galaxies," *Monthly Notices of the Royal Astronomical Society*, 512: 2371, 2022.
- Holdship, Jonathan; Mangum, Jeffrey G.; Viti, Serena; Behrens, Erica; Harada, Nanase; Martín, Sergio; Sakamoto, Kazushi; Muller, Sebastien; Tanaka, Kunihiro; Nakanishi, Kouichiro; Herrero-Illana, Rubén; Yoshimura, Yuki; Aladro, Rebeca; Colzi, Laura; Emig, Kimberly L.; Henkel, Christian; Nishimura, Yuri; Rivilla, Víctor M.; Van Der Werf, Paul P.; Alma Comprehensive High-Resolution Extragalactic Molecular Inventory (Alchemi) Collaboration "Energizing Star Formation: The Cosmic-Ray Ionization Rate in NGC 253 Derived from ALCHEMI Measurements of H3O+ and SO," *The Astrophysical Journal*, 931: 89, 2022.
- Holoien, Thomas W.-S.; Neustadt, Jack M. M.; Vallye, Patrick J.; Auchettl, Katie; Hinkle, Jason T.; Romero-Cañizales, Cristina; Shappee, Benjamin J.; Kochanek, Christopher S.; Stanek, K. Z.; Chen, Ping; Dong, Subo; Prieto, Jose L.; Thompson, Todd A.; Brink, Thomas G.; Filippenko, Alexei V.; Zheng, Weikang; Bersier, David; Bose, Subhash; Burgasser, Adam J.; Channa, Sanyum; De Jaeger, Thomas; Hestenes, Julia; Im, Myungshin; Jeffers, Benjamin; Jun, Hyunsung D.; Lansbury, George; Post, Richard S.; Ross, Timothy W.; Stern, Daniel; Tang, Kevin; Tucker, Michael A.; Valenti, Stefano; Yunus, Sameen; Zhang, Keto D. "Investigating the Nature of the Luminous Ambiguous Nuclear Transient ASASSN-17jz," *The Astrophysical Journal*, 933: 196, 2022.
- Howard, Ward S.; Macgregor, Meredith A.; Osten, Rachel; Forbrich, Jan; Cranmer, Steven R.; Tristan, Isaiah; Weinberger, Alycia J.; Youngblood, Allison; Barclay, Thomas; Parke Loyd, R. O.; Shkolnik, Evgenya L.; Zic, Andrew; Wilner, David J. "The Mouse That Squeaked: A Small Flare from Proxima Cen Observed in the Millimeter, Optical, and Soft X-Ray with Chandra and ALMA," *The Astrophysical Journal*, 938: 103, 2022.
- Hsu, Shih-Ying; Liu, Sheng-Yuan; Liu, Tie; Sahu, Dipen; Lee, Chin-Fei; Tatematsu, Kenichi; Kim, Kee-Tae; Hirano, Naomi; Yang, Yao-Lun; Johnstone, Doug; Liu, Hongli; Juvela, Mika; Bronfman, Leonardo; Chen, Huei-Ru Vivien; Dutta, Somnath; Eden, David J.; Jhan, Kai-Syun; Kuan, Yi-Jehng; Lee, Chang Won; Lee, Jeong-Eun; Li, Shanghuo; Liu, Chun-Fan; Qin, Sheng-Li; Sanhueza, Patricio; Shang, Hsien; Soam, Archana; Traficante, Alessio; Zhou, Jianjun "ALMA Survey of Orion Planck Galactic Cold Clumps (ALMASOP): A Hot Corino Survey toward Protostellar Cores in the Orion Cloud," *The Astrophysical Journal*, 927: 218, 2022.
- Hu, Yue; Lazarian, A.; Beck, Rainer; Xu, Siyao "Role of Magnetic Fields in Fueling Seyfert Nuclei," *The Astrophysical Journal*, 941: 92, 2022.
- Huang, Jane; Ginski, Christian; Benisty, Myriam; Ren, Bin; Bohn, Alexander J.; Choquet, Élodie; Öberg, Karin I.; Ribas, Álvaro; Bae, Jaehan; Bergin, Edwin A.; Birnstiel, Til; Boehler, Yann; Facchini, Stefano; Harsono, Daniel; Hogerheijde, Michiel; Long, Feng; Manara, Carlo F.; Ménard, François; Pinilla, Paola; Pinte, Christophe; Rab, Christian; Williams, Jonathan P.; Zurlo, Alice "Disk Evolution Study through Imaging of Nearby Young Stars (DESTINYS): A Panchromatic View of DO Tau's Complex Kilo-astronomical-unit Environment," *The Astrophysical Journal*, 930: 171, 2022.
- Huang, L.; Chang, Z. X. "A cosmological distance measure using radio-loud quasars," *Monthly Notices of the Royal Astronomical Society*, 515: 1358, 2022.
- Huang, Yun; Lee, Kyoung-Soo; Cucciati, Olga; Lemaux, Brian C.; Sawicki, Marc; Malavasi, Nicola; Ramakrishnan, Vandana; Xue, Rui; Cassara, Letizia P.; Chiang, Yi-Kuan; Dey, Arjun; Gwyn, Stephen D. J.; Hathri, Nimish; Pentericci, Laura; Prescott, Moire K. M.; Zamorani, Gianni "Evaluating Ly $\alpha$  Emission as a Tracer of the Largest Cosmic Structure at z 2.47," *The Astrophysical Journal*, 941: 134, 2022.
- Hull, Charles L. H.; Yang, Haifeng; Cortés, Paulo C.; Dent, William R. F.; Kral, Quentin; Li, Zhi-Yun; Le Gouellec, Valentin J. M.; Hughes, A. Meredith; Milli, Julien; Teague, Richard; Wyatt, Mark C. "Polarization from Aligned Dust Grains in the  $\beta$  Pic Debris Disk," *The Astrophysical Journal*, 930: 49, 2022.
- Humire, P. K.; Henkel, C.; Hernández-Gómez, A.; Martín, S.; Mangum, J.; Harada, N.; Muller, S.; Sakamoto, K.; Tanaka, K.; Yoshimura, Y.; Nakanishi, K.; Mühle, S.; Herrero-Illana, R.; Meier, D. S.; Caux, E.; Aladro, R.; Mauersberger, R.; Viti, S.; Colzi, L.; Rivilla, V. M.; Gorski, M.; Menten, K. M.; Huang, K.-Y.; Aalto, S.; Van Der Werf, P. P.; Emig, K. L. "Methanol masers in NGC 253 with ALCHEMI," *Astronomy and Astrophysics*, 663: A33, 2022.
- Hunter, Laura Congreve; Van Zee, Liese; McQuinn, Kristen B. W.; Garner, Ray; Dolphin, Andrew E. "Determining the Timescale over Which Stellar Feedback Drives Turbulence in the Interstellar Medium: A Study of Four Nearby Dwarf Irregular Galaxies," *The Astronomical Journal*, 163: 132, 2022.
- Husemann, B.; Singha, M.; Scharwächter, J.; Mcelroy, R.; Neumann, J.; Smirnova-Pinchukova, I.; Urrutia, T.; Baum, S. A.; Bennert, V. N.; Combes, F.; Croom, S. M.; Davis, T. A.; Fournier, Y.; Galkin, A.; Gaspari, M.; Enke, H.; Krumpke, M.; O'Dea, C. P.; Pérez-Torres, M.; Rose, T.; Tremblay, G. R.; Walcher, C. J. "The Close AGN Reference Survey (CARS). IFU survey data and the BH mass dependence of long-term AGN variability," *Astronomy and Astrophysics*, 659: A124, 2022.
- Hutschenreuter, S.; Anderson, C. S.; Betti, S.; Bower, G. C.; Brown, J.-A.; Brüggem, M.; Carretti, E.; Clarke, T.; Clegg, A.; Costa, A.; Croft, S.; Eck, C. V.; Gaensler, B. M.; De Gasperin, F.; Haverkorn, M.; Heald, G.; Hull, C. L. H.; Inoue, M.; Johnston-Hollitt, M.; Kaczmarek, J.; Law, C.; Ma, Y. K.; Macmahon, D.; Mao, S. A.; Riseley, C.; Roy, S.; Shanahan, R.; Shimwell, T.; Stil, J.; Sobey, C.; O'Sullivan, S. P.; Tasse, C.; Vacca, V.; Vernstrom, T.; Williams, P. K. G.; Wright, M.; Enßlin, T. A. "The Galactic Faraday rotation sky 2020," *Astronomy and Astrophysics*, 657: A43, 2022.
- Hwang, Jihye; Kim, Jongsoo; Pattle, Kate; Lee, Chang Won; Koch, Patrick M.; Johnstone, Doug; Tomisaka, Kohji; Whitworth, Anthony; Furuya, Ray S.; Kang, Ji-Hyun; Lyo, A. -Ran; Chung, Eun Jung; Arzoumanian, Doris; Park, Geumsook; Kwon, Woojin; Kim, Shinyoung; Tamura, Motohide; Kwon, Jungmi; Soam, Archana; Han, Ilseung; Hoang, Thiem; Kim, Kyoung Hee; Onaka, Takashi; Eswaraiah, Chakali; Ward-Thompson, Derek; Liu, Hong-Li; Tang, Xindi; Chen, Wen Ping; Matsumura, Masafumi; Hoang, Thuong Duc; Chen, Zhiwei; Le Gouellec, Valentin J. M.; Kirchschrager,

- Florian; Poidevin, Frédéric; Bastien, Pierre; Qiu, Keping; Hasegawa, Tetsuo; Lai, Shih-Ping; Byun, Do-Young; Cho, Jungyeon; Choi, Minho; Choi, Youngwoo; Choi, Yunhee; Jeong, Il-Gyo; Kang, Miju; Kim, Hysung; Kim, Kee-Tae; Lee, Jeong-Eun; Lee, Sang-Sung; Lee, Yong-Hee; Lee, Hyeeseung; Kim, Mi-Ryang; Yoo, Hyunju; Yun, Hyeong-Sik; Chen, Mike; Francesco, James Di; Fiege, Jason; Fissel, Laura M.; Franzmann, Erica; Houde, Martin; Lacaille, Kevin; Matthews, Brenda; Sadavoy, Sarah; Moriarty-Schieven, Gerald; Tahani, Mehrnoosh; Ching, Tao-Chung; Dai, Y. Sophia; Duan, Yan; Gu, Qilao; Law, Chi-Yan; Li, Dalei; Li, Di; Li, Guangxing; Li, Hua-Bai; Liu, Tie; Lu, Xing; Qian, Lei; Wang, Hongchi; Wu, Jintai; Xie, Jinjin; Yuan, Jinghua; Zhang, Chuan-Peng; Zhang, Guoyin; Zhang, Yapeng; Zhou, Jianjun; Zhu, Lei; Berry, David; Friberg, Per; Graves, Sarah; Liu, Junhao; Mairs, Steve; Parsons, Harriet; Rawlings, Mark; Doi, Yasuo; Hayashi, Saeko; Hull, Charles L. H.; Inoue, Tsuyoshi; Inutsuka, Shu-Ichiro; Iwasaki, Kazunari; Kataoka, Akimasa; Kawabata, Koji; Kim, Gwanjeong; Kobayashi, Masato I. N.; Nagata, Tetsuya; Nakamura, Fumitaka; Nakanishi, Hiroyuki; Pyo, Tae-Soo; Saito, Hiro; Seta, Masumichi; Shimajiri, Yoshito; Shinnaga, Hiroko; Tsukamoto, Yusuke; Zenko, Tetsuya; Chen, Huei-Ru Vivien; Duan, Hao-Yuan; Fanciullo, Lapo; Kemper, Francisca; Lee, Chin-Fei; Lin, Sheng-Jun; Liu, Sheng-Yuan; Ohashi, Nagayoshi; Rao, Ramprasad; Tang, Ya-Wen; Wang, Jia-Wei; Yang, Meng-Zhe; Yen, Hsi-Wei; Bourke, Tyler L.; Chrysostomou, Antonio; Debattista, Victor; Eden, David; Eyres, Stewart; Falle, Sam; Fuller, Gary; Gledhill, Tim; Greaves, Jane; Griffin, Matt; Hatchell, Jennifer; Karoly, Janik; Kirk, Jason; Könyves, Vera; Longmore, Steven; Van Loo, Sven; De Looze, Ilse; Peretto, Nicolas; Priestley, Felix; Rawlings, Jonathan; Retter, Brendan; Richer, John; Rigby, Andrew; Savini, Giorgio; Scaife, Anna; Viti, Serena; Diep, Pham Ngoc; Ngoc, Nguyen Bich; Tram, Le Ngoc; André, Philippe; Coudé, Simon; Dowell, C. Darren; Friesen, Rachel; Robitaille, Jean-François "The JCMT BISTRO Survey: A Spiral Magnetic Field in a Hub-filament Structure, Monoceros R2," *The Astrophysical Journal*, 941: 51, 2022.
- Ighina, L.; Moretti, A.; Tavecchio, F.; Caccianiga, A.; Belladitta, S.; Dallacasa, D.; Della Ceca, R.; Sbarrato, T.; Spingola, C. "Direct observation of an extended X-ray jet at  $z = 6.1$ ," *Astronomy and Astrophysics*, 659: A93, 2022.
- Ighina, Luca; Leung, James K.; Broderick, Jess W.; Drouart, Guillaume; Seymour, Nick; Belladitta, Silvia; Caccianiga, Alessandro; Lenc, Emil; Moretti, Alberto; An, Tao; Galvin, Tim J.; Heald, George H.; Huynh, Minh T.; McConnell, David; Murphy, Tara; Pritchard, Joshua; Quici, Benjamin; Shabala, Stas S.; Tingay, Steven J.; Turner, Ross J.; Wang, Yuanming; White, Sarah V. "Constraining the radio properties of the  $z = 6.44$  QSO VIK J2318-3113," *Astronomy and Astrophysics*, 663: A73, 2022.
- Ignesti, Alessandro; Vulcani, Benedetta; Poggianti, Bianca M.; Paladino, Rosita; Shimwell, Timothy; Healy, Julia; Gitti, Myriam; Bacchini, Cecilia; Moretti, Alessia; Radovich, Mario; Van Weeren, Reinout J.; Roberts, Ian D.; Botteon, Andrea; Müller, Ancla; Mcgee, Sean; Fritz, Jacopo; Tomičić, Neven; Werle, Ariel; Mingozzi, Matilde; Gullieuszik, Marco; Verheijen, Marc "GASP XXXVIII: The LOFAR-MeerKAT-VLA View on the Nonthermal Side of a Jellyfish Galaxy," *The Astrophysical Journal*, 924: 64, 2022.
- Ihle, Håvard T.; Borowska, Jowita; Cleary, Kieran A.; Eriksen, Hans Kristian; Foss, Marie K.; Harper, Stuart E.; Kim, Junhan; Lunde, Jonas G. S.; Philip, Liju; Rasmussen, Maren; Stutzer, Nils-Ole; Uzgil, Bade D.; Watts, Duncan J.; Wehus, Ingunn Kathrine; Bond, J. Richard; Breyse, Patrick C.; Catha, Morgan; Church, Sarah E.; Chung, Dongwoo T.; Dickinson, Clive; Dunne, Delaney A.; Gaier, Todd; Gundersen, Joshua Ott; Harris, Andrew I.; Hobbs, Richard; Lamb, James W.; Lawrence, Charles R.; Murray, Norman; Readhead, Anthony C. S.; Padmanabhan, Hamsa; Pearson, Timothy J.; Rennie, Thomas J.; Woody, David P.; Compap Collaboration "COMAP Early Science. IV. Power Spectrum Methodology and Results," *The Astrophysical Journal*, 933: 185, 2022.
- Ikeda, Ryota; Tadaki, Ken-Ichi; Iono, Daisuke; Kodama, Tadayuki; Chan, Jeffrey C. C.; Hatsukade, Bunyo; Hayashi, Masao; Izumi, Takuma; Kohno, Kotaro; Koyama, Yusei; Shimakawa, Rhythm; Suzuki, Tomoko L.; Tamura, Yoichi; Tanaka, Ichi "High-resolution ALMA Study of CO J = 2-1 Line and Dust Continuum Emissions in Cluster Galaxies at  $z = 1.46$ ," *The Astrophysical Journal*, 933: 11, 2022.
- Ilyushin, V. V.; Müller, H. S. P.; Jørgensen, J. K.; Bauerecker, S.; Maul, C.; Bakhmat, Y.; Alekseev, E. A.; Dorovskaya, O.; Vlasenko, S.; Lewen, F.; Schlemmer, S.; Berezkin, K.; Lees, R. M. "Rotational and rovibrational spectroscopy of CD3OH with an account of CD3OH toward IRAS 16293-2422," *Astronomy and Astrophysics*, 658: A127, 2022.
- Imai, Muneaki; Oya, Yoko; Svoboda, Brian; Liu, Hanyu Baobab; Lefloch, Bertrand; Viti, Serena; Zhang, Yichen; Ceccarelli, Cecilia; Codella, Claudio; Chandler, Claire J.; Sakai, Nami; Aikawa, Yuri; Alves, Felipe O.; Balucani, Nadia; Bianchi, Eleonora; Bouvier, Mathilde; Busquet, Gemma; Caselli, Paola; Caux, Emmanuel; Charley, Steven; Choudhury, Spandan; Cuello, Nicolas; Simone, Marta De; Dulieu, Francois; Durán, Aurora; Evans, Lucy; Favre, Cécile; Fedele, Davide; Feng, Siyi; Fontani, Francesco; Francis, Logan; Hama, Tetsuya; Hanawa, Tomoyuki; Herbst, Eric; Hirano, Shingo; Hirota, Tomoya; Isella, Andrea; Jiménez-Serra, Izaskun; Johnstone, Doug; Kahane, Claudine; Le Gal, Romane; Loinard, Laurent; López-Sepulcre, Ana; Maud, Luke T.; Maureira, María José; Menard, Francois; Mercimek, Seyma; Miotello, Anna; Moellenbrock, George; Mori, Shoji; Murillo, Nadia M.; Nakatani, Riouhei; Nomura, Hideko; Oba, Yasuhiro; O'Donoghue, Ross; Ohashi, Satoshi; Okoda, Yuki; Ospina-Zamudio, Juan; Pineda, Jaime; Podio, Linda; Rimola, Albert; Sakai, Takeshi; Segura-Cox, Dominique; Shirley, Yancy; Taquet, Vianney; Testi, Leonardo; Vastel, Charlotte; Watanabe, Naoki; Watanabe, Yoshimasa; Witzel, Arezu; Xue, Ci; Zhao, Bo; Yamamoto, Satoshi "Chemical and Physical Characterization of the Isolated Protostellar Source CB68: FAUST IV," *The Astrophysical Journal*, 934: 70, 2022.
- Imanishi, Masatoshi; Nakanishi, Kouichiro; Izumi, Takuma; Baba, Shunsuke "ALMA Sub-arcsecond-resolution 183 GHz H<sub>2</sub>O and Dense Molecular Line Observations of Nearby Ultraluminous Infrared Galaxies," *The Astrophysical Journal*, 926: 159, 2022.
- Inami, Hanae; Algera, Hiddo S. B.; Schouws, Sander; Sommovigo, Laura; Bouwens, Rychard; Smit, Renske; Stefanon, Mauro; Bowler, Rebecca A. A.; Endsley, Ryan; Ferrara, Andrea; Oesch, Pascal; Stark, Daniel; Aravena, Manuel; Barrufet, Laia; Da Cunha, Elisabete; Dayal, Pratika; De Looze, Ilse; Fudamoto, Yoshinobu; Gonzalez, Valentino; Graziani, Luca; Hodge, Jacqueline A.; Hygate, Alexander P. S.; Nanayakkara, Themiya; Pallottini, Andrea; Riechers, Dominik A.; Schneider, Raffaella; Topping, Michael; Van Der Werf, Paul "The ALMA REBELS Survey: dust continuum detections at  $z > 6.5$ ," *Monthly Notices of the Royal Astronomical Society*, 515: 3126, 2022.
- Inami, Hanae; Surace, Jason; Armus, Lee; Evans, Aaron S.; Larson, Kirsten L.; Barcos-Munoz, Loreto; Stierwalt, Sabrina; Mazzarella, Joseph M.; Privon, George C.; Song, Yiqing; Linden, Sean T.; Hayward, Christopher C.; Böker, Torsten; U, Vivian; Bohn, Thomas; Charmandaris, Vassilis; Diaz-Santos, Tanio; Howell, Justin H.; Lai, Thomas; Medling, Anne M.; Rich, Jeffrey A.; Aalto, Susanne; Appleton, Philip; Brown, Michael J. I.; Hoshioka, Shunshi; Iwasawa, Kazushi; Kemper, Francisca; Law, David; Malkan, Matthew A.; Marshall, Jason; Murphy, Eric J.; Sanders, David; Van Der Werf, Paul "GOALS-JWST: Unveiling Dusty Compact Sources in the Merging Galaxy IIZw096," *The Astrophysical Journal*, 940: L6, 2022.
- Ingallinera, A.; Cavallaro, F.; Loru, S.; Marvil, J.; Umana, G.; Triggilio, C.; Breen, S.; Bordiu, C.; Buemi, C. S.; Bufano, F.; Collier, J.; Etoka, S.; Filipović, M. D.; Goldman, S. R.; Hopkins, A. M.; Koribalski, B. S.; Leto, P.; Norris, R. P.; Riggi, S.; Schillirò, F.; Tremblay, C.; Van Loon, J. Th "Evolutionary Map of the Universe (EMU): 18-cm OH-maser discovery in ASKAP continuum images of the SCORPIO field," *Monthly Notices of the Royal Astronomical Society*, 512: L21-L26, 2022.
- Irwin, Judith; Dyer, Jacqueline; Drake, Leonardo; Wang, Q. Daniel; Stil, Jeroen; Stein, Yelena; English, Jayanne; Wiegert, Theresa "CHANG-ES XXVII: A radio/X-ray catalogue of compact sources in and around edge-on galaxies," *Monthly Notices of the Royal Astronomical Society*, 512: 5755, 2022.

## APPENDIX A: PUBLICATIONS

- Issaoun, Sara; Wielgus, Maciek; Jorstad, Svetlana; Krichbaum, Thomas P.; Blackburn, Lindy; Janssen, Michael; Chan, Chi-Kwan; Pesce, Dominic W.; Gómez, José L.; Akiyama, Kazunori; Mościbrodzka, Monika; Martí-Vidal, Iván; Chael, Andrew; Lico, Rocco; Liu, Jun; Ramakrishnan, Venkatesh; Lisakov, Mikhail; Fuentes, Antonio; Zhao, Guang-Yao; Moriyama, Kotaro; Broderick, Avery E.; Tiede, Paul; Macdonald, Nicholas R.; Mizuno, Yosuke; Traianou, Efthalia; Loinard, Laurent; Davelaar, Jordy; Gurwell, Mark; Lu, Ru-Sen; Alberdi, Antxon; Alef, Walter; Algaba, Juan Carlos; Anantua, Richard; Asada, Keiichi; Azulay, Rebecca; Bach, Uwe; Baczko, Anne-Kathrin; Ball, David; Baloković, Mislav; Barrett, John; Bauböck, Michi; Benson, Bradford A.; Bintley, Dan; Blundell, Raymond; Boland, Wilfred; Bouman, Katherine L.; Bower, Geoffrey C.; Boyce, Hope; Bremer, Michael; Brinkerink, Christiaan D.; Brissenden, Roger; Britzen, Silke; Brogiere, Dominique; Bronzwaer, Thomas; Bustamante, Sandra; Byun, Do-Young; Carlstrom, John E.; Ceccobello, Chiara; Chatterjee, Koushik; Chatterjee, Shami; Chen, Ming-Tang; Chen, Yongjun; Cho, Ilje; Christian, Pierre; Conroy, Nicholas S.; Conway, John E.; Cordes, James M.; Crawford, Thomas M.; Crew, Geoffrey B.; Cruz-Osorio, Alejandro; Cui, Yuzhu; Laurentis, Mariafelicia De; Deane, Roger; Dempsey, Jessica; Desvignes, Gregory; Dexter, Jason; Doeleman, Sheperd S.; Dhruv, Vedant; Dzib Quijano, Sergio Abraham; Eatough, Ralph P.; Emami, Razieh; Falcke, Heino; Farah, Joseph; Fish, Vincent L.; Fomalont, Ed; Ford, H. Alyson; Fraga-Encinas, Raquel; Freeman, William T.; Friberg, Per; Fromm, Christian M.; Galison, Peter; Gammie, Charles F.; García, Roberto; Gentaz, Olivier; Georgiev, Boris; Goddi, Ciriaco; Gold, Roman; Gómez-Ruiz, Arturo I.; Gu, Minfeng; Hada, Kazuhiro; Haggard, Daryl; Hecht, Michael H.; Hesper, Ronald; Ho, Luis C.; Ho, Paul; Honma, Mareki; Huang, Chih-Wei L.; Huang, Lei; Hughes, David H.; Ikeda, Shiro; Impellizzeri, C. M. Violette; Inoue, Makoto; James, David J.; Jannuzi, Buell T.; Jeter, Britton; Jiang, Wu; Jimenez-Rosales, Alejandra; Johnson, Michael D.; Joshi, Abhishek V.; Jung, Taehyun; Karami, Mansour; Karuppusamy, Ramesh; Kawashima, Tomohisa; Keating, Garrett K.; Kettenis, Mark; Kim, Dong-Jin; Kim, Jae-Young; Kim, Jongsoo; Kim, Junhan; Kino, Motoki; Koay, Jun Yi; Kocherlakota, Prashant; Kofuji, Yutaro; Koch, Patrick M.; Koyama, Shoko; Kramer, Carsten; Kramer, Michael; Kuo, Cheng-Yu; Bella, Noemi La; Lauer, Tod R.; Lee, Daeyoung; Lee, Sang-Sung; Leung, Po Kin; Levis, Aviad; Li, Zhiyuan; Lico, Rocco; Lindahl, Greg; Lindqvist, Michael; Liu, Kuo; Liuzzo, Elisabetta; Lo, Wen-Ping; Lobanov, Andrei P.; Lonsdale, Colin; Mao, Jirong; Marchili, Nicola; Markoff, Sera; Marrone, Daniel P.; Marscher, Alan P.; Matsushita, Satoki; Matthews, Lynn D.; Medeiros, Lia; Menten, Karl M.; Michalik, Daniel; Mizuno, Izumi; Mizuno, Yosuke; Moran, James M.; Müller, Cornelia; Mus, Alejandro; Musoke, Gibwa; Myserlis, Ioannis; Nadolski, Andrew; Nagai, Hiroshi; Nagar, Neil M.; Nakamura, Masanori; Narayan, Ramesh; Narayanan, Gopal; Natarajan, Iniyam; Nathanail, Antonios; Neilsen, Joey; Neri, Roberto; Ni, Chunhong; Noutsos, Aristeidis; Nowak, Michael A.; Oh, Junghwan; Okino, Hiroki; Olivares, Héctor; Ortiz-León, Gisela N.; Oyama, Tomoaki; Özel, Feryal; Palumbo, Daniel C. M.; Paraschos, Georgios Filippou; Park, Jongho; Parsons, Harriet; Patel, Nimesh; Pen, Ue-Li; Piétu, Vincent; Plambeck, Richard; Popstefanija, Aleksandar; Porth, Oliver; Pötzel, Felix M.; Prather, Ben; Preciado-López, Jorge A.; Psaltis, Dimitrios; Pu, Hung-Yi; Rao, Ramprasad; Rawlings, Mark G.; Raymond, Alexander W.; Rezzolla, Luciano; Ricarte, Angelo; Ripperda, Bart; Roelofs, Freek; Rogers, Alan; Ros, Eduardo; Romero-Canizales, Cristina; Roshanineshat, Arash; Rottmann, Helge; Roy, Alan L.; Ruiz, Ignacio; Ruszczyk, Chet; Rygl, Kazi L. J.; Sánchez, Salvador; Sánchez-Arguelles, David; Sanchez-Portal, Miguel; Sasada, Mahito; Satapathy, Kaushik; Savolainen, Tuomas; Schloerb, F. Peter; Schuster, Karl-Friedrich; Shao, Lijing; Shen, Zhiqiang; Small, Des; Sohn, Bong Won; Soohoo, Jason; Souccar, Kamal; Sun, He; Tazaki, Fumie; Tetarenko, Alexandra J.; Tiede, Paul; Tilanus, Remo P. J.; Titus, Michael; Torne, Pablo; Trent, Tyler; Trippa, Sascha; Van Bemmel, Ilse; Van Langevelde, Huib Jan; Van Rossum, Daniel R.; Vos, Jesse; Wagner, Jan; Ward-Thompson, Derek; Wardle, John; Weintraub, Jonathan; Wex, Norbert; Wharton, Robert; Wiik, Kaj; Witzel, Gunther; Wondrak, Michael; Wong, George N.; Wu, Qingwen; Yamaguchi, Paul; Yoon, Doosoo; Young, André; Young, Ken; Younsi, Ziri; Yuan, Feng; Yuan, Ye-Fei; Zensus, J. Anton; Zhang, Shuo; Zhao, Shan-Shan "Resolving the Inner Parsec of the Blazar J1924-2914 with the Event Horizon Telescope," *The Astrophysical Journal*, 934: 145, 2022.
- Izquierdo-Villalba, David; Sesana, Alberto; Bonoli, Silvia; Colpi, Monica "Massive black hole evolution models confronting the n-Hz amplitude of the stochastic gravitational wave background," *Monthly Notices of the Royal Astronomical Society*, 509: 3488, 2022.
- Jacobson-Galán, W. V.; Dessart, L.; Jones, D. O.; Margutti, R.; Coppejans, D. L.; Dimitriadis, G.; Foley, R. J.; Kilpatrick, C. D.; Matthews, D. J.; Rest, S.; Terreran, G.; Aleo, P. D.; Auchettl, K.; Blanchard, P. K.; Coulter, D. A.; Davis, K. W.; De Boer, T. J. L.; Demarchi, L.; Drout, M. R.; Earl, N.; Gagliano, A.; Gall, C.; Hjorth, J.; Huber, M. E.; Ibiak, A. L.; Milisavljevic, D.; Pan, Y.-C.; Rest, A.; Ridden-Harper, R.; Rojas-Bravo, C.; Siebert, M. R.; Smith, K. W.; Taggart, K.; Tinyanton, S.; Wang, Q.; Zenati, Y. "Final Moments. I. Precursor Emission, Envelope Inflation, and Enhanced Mass Loss Preceding the Luminous Type II Supernova 2020tfl," *The Astrophysical Journal*, 924: 15, 2022.
- Jaiswal, Sumit; An, Tao; Wang, Ailing; Tingay, Steven "VLBI properties of compact interplanetary scintillators detected by the Murchison Widefield Array," *Monthly Notices of the Royal Astronomical Society*, 509: 2122, 2022.
- James, Mackenzie M.; Pascucci, Ilaria; Liu, Yao; Banzatti, Andrea; Krijt, Sebastiaan; Long, Feng; Kamp, Inga "Testing the Retrieval of Inner Disk Water Enrichment with Spitzer/IRS and JWST/MIRI," *The Astrophysical Journal*, 941: 187, 2022.
- Järvelä, E.; Dahale, R.; Crepaldi, L.; Berton, M.; Congiu, E.; Antonucci, R. "Unravelling the origin of extended radio emission in narrow-line Seyfert 1 galaxies with the JVLA," *Astronomy and Astrophysics*, 658: A12, 2022.
- Jennings, Jeff; Tazzari, Marco; Clarke, Cathie J.; Booth, Richard A.; Rosotti, Giovanni P. "Superresolution trends in the ALMA Taurus survey: structured inner discs and compact discs," *Monthly Notices of the Royal Astronomical Society*, 514: 6053, 2022.
- Jhan, Kai-Syun; Lee, Chin-Fei; Johnstone, Doug; Liu, Tie; Liu, Sheng-Yuan; Hirano, Naomi; Tatematsu, Ken'ichi; Dutta, Somnath; Moraghan, Anthony; Shang, Hsien; Lee, Jeong-Eun; Li, Shanghuo; Liu, Chun-Fan; Hsu, Shih-Ying; Kwon, Woojin; Sahu, Dipen; Liu, Xun-Chuan; Kim, Kee-Tae; Luo, Qiuyi; Qin, Sheng-Li; Sanhueza, Patricio; Bronfman, Leonardo; Qizhou, Zhang; Eden, David; Traficante, Alessio; Lee, Chang Won; Almasop Team "ALMA Survey of Orion Planck Galactic Cold Clumps (ALMASOP): Deriving Inclination Angle and Velocity of the Protostellar Jets from Their SiO Knots," *The Astrophysical Journal*, 931: L5, 2022.
- Jiménez-Palau, C.; Solanes, J. M.; Perea, J. D.; Del Olmo, A.; Tous, J. L. "The local universe in the era of large surveys - II. multi-wavelength characterization of activity in nearby SO galaxies," *Monthly Notices of the Royal Astronomical Society*, 515: 3956, 2022.
- Jin, Shuowen; Daddi, Emanuele; Magdis, Georgios E.; Liu, Daizhong; Weaver, John R.; Tan, Qinghua; Valentino, Francesco; Gao, Yu; Schinnerer, Eva; Calabrò, Antonello; Gu, Qiuhseng; Sese, David Blaquez "Diagnosing deceptively cold dusty galaxies at  $3.5 < z < 6$ : A substantial population of compact starbursts with high infrared optical depths," *Astronomy and Astrophysics*, 665: A3, 2022.
- Jones, Michael G.; Sand, David J.; Bellazzini, Michele; Spekkens, Kristine; Cannon, John M.; Mutlu-Pakdil, Burçin; Karunakaran, Ananthan; Beccari, Giacomo; Magrini, Laura; Cresci, Giovanni; Inoue, John L.; Fuson, Jackson; Adams, Elizabeth A. K.; Battaglia, Giuseppina; Bennet, Paul; Crnojević, Denija; Caldwell, Nelson; Guhathakurta, Puragra; Haynes, Martha P.; Muñoz, Ricardo R.; Seth, Anil; Strader, Jay; Toloba, Elisa; Zaritsky, Dennis "AGC 226178 and NGVS 3543: Two Deceptive Dwarfs toward Virgo," *The Astrophysical Journal*, 926: L15, 2022.
- Jones, Michael G.; Sand, David J.; Bellazzini, Michele; Spekkens, Kristine; Karunakaran, Ananthan; Adams, Elizabeth A. K.; Battaglia, Giuseppina;



- Beccari, Giacomo; Bennet, Paul; Cannon, John M.; Cresci, Giovanni; Crnojević, Denija; Caldwell, Nelson; Fuson, Jackson; Guhathakurta, Puragra; Haynes, Martha P.; Inoue, John L.; Magrini, Laura; Muñoz, Ricardo R.; Mutlu-Pakdil, Burçin; Seth, Anil; Strader, Jay; Toloba, Elisa; Zaritsky, Dennis "Young, Blue, and Isolated Stellar Systems in the Virgo Cluster. II. A New Class of Stellar System," *The Astrophysical Journal*, 935: 51, 2022.
- Jørgensen, Jes K.; Kuruwita, Rajika L.; Harsono, Daniel; Haugbølle, Troels; Kristensen, Lars E.; Bergin, Edwin A. "Binarity of a protostar affects the evolution of the disk and planets," *Nature*, 606: 272, 2022.
- Jorstad, S. G.; Marscher, A. P.; Raiteri, C. M.; Villata, M.; Weaver, Z. R.; Zhang, H.; Dong, L.; Gómez, J. L.; Perel, M. V.; Savchenko, S. S.; Larionov, V. M.; Carosati, D.; Chen, W. P.; Kurtanidze, O. M.; Marchini, A.; Matsumoto, K.; Mortari, F.; Aceti, P.; Acosta-Pulido, J. A.; Andreeva, T.; Apolonio, G.; Arena, C.; Arkharov, A.; Bachev, R.; Banfi, M.; Bonnoli, G.; Borman, G. A.; Bozhilov, V.; Carnerero, M. I.; Damjanovic, G.; Ehgamberdiev, S. A.; Elsässer, D.; Frasca, A.; Gabellini, D.; Grishina, T. S.; Gupta, A. C.; Hagen-Thorn, V. A.; Hallum, M. K.; Hart, M.; Hasuda, K.; Hemrich, F.; Hsiao, H. Y.; Ibraymov, S.; Irsamambetova, T. R.; Ivanov, D. V.; Joner, M. D.; Kimeridze, G. N.; Klimanov, S. A.; Knött, J.; Kopatskaya, E. N.; Kurtanidze, S. O.; Kurtenkov, A.; Kuutma, T.; Larionova, E. G.; Leonini, S.; Lin, H. C.; Lorey, C.; Mannheim, K.; Marino, G.; Minev, M.; Mirzaqulov, D. O.; Morozova, D. A.; Nikiforova, A. A.; Nikolashvili, M. G.; Ovcharov, E.; Papini, R.; Pursimo, T.; Rahimov, I.; Reinhart, D.; Sakamoto, T.; Salvaggio, F.; Semkov, E.; Shakhovskoy, D. N.; Sigua, L. A.; Steineke, R.; Stojanovic, M.; Strigachev, A.; Troitskaya, Y. V.; Troitskiy, I. S.; Tsai, A.; Valcheva, A.; Vasilyev, A. A.; Vince, O.; Waller, L.; Zaharieva, E.; Chatterjee, R. "Rapid quasi-periodic oscillations in the relativistic jet of BL Lacertae," *Nature*, 609: 265, 2022.
- Joseph, P.; George, K.; Paul, K. T. "Active galactic nucleus feedback in NGC 3982," *Astronomy and Astrophysics*, 667: A88, 2022.
- Kabasares, Kyle M.; Barth, Aaron J.; Buote, David A.; Boizelle, Benjamin D.; Walsh, Jonelle L.; Baker, Andrew J.; Darling, Jeremy; Ho, Luis C.; Cohn, Jonathan "Black Hole Mass Measurements of Early-type Galaxies NGC 1380 and NGC 6861 through ALMA and HST Observations and Gas-dynamical Modeling," *The Astrophysical Journal*, 934: 162, 2022.
- Kakkad, D.; Sani, E.; Rojas, A. F.; Mallmann, Nicolas D.; Veilleux, S.; Bauer, Franz E.; Ricci, F.; Mushotsky, R.; Koss, M.; Ricci, C.; Treister, E.; Privon, George C.; Nguyen, N.; Bär, R.; Harrison, F.; Oh, K.; Powell, M.; Riffel, R.; Stern, D.; Trakhtenbrot, B.; Urry, C. M. "BASS XXXI: Outflow scaling relations in low redshift X-ray AGN host galaxies with MUSE," *Monthly Notices of the Royal Astronomical Society*, 511: 2105, 2022.
- Kalita, Boris S.; Daddi, Emanuele; Bournaud, Frederic; Rich, Robert Michael; Valentino, Francesco; Gómez-Guijarro, Carlos; Codis, Sandrine; Delvecchio, Ivan; Elbaz, David; Strazzullo, Veronica; De Souza Magalhaes, Victor; Pety, Jérôme; Tan, Qinghua "Bulge formation inside quiescent lopsided stellar disks: Connecting accretion, star formation, and morphological transformation in a  $z \sim 3$  galaxy group," *Astronomy and Astrophysics*, 666: A44, 2022.
- Kamiński, Tomek; Mazurek, Helena J.; Menten, Karl M.; Tylenda, Romuald "A search for cool molecular gas in GK Persei and other classical novae," *Astronomy and Astrophysics*, 659: A109, 2022.
- Kaneko, Hiroyuki; Kuno, Nario; Iono, Daisuke; Tamura, Yoichi; Tosaki, Tomoka; Nakanishi, Kouichiro; Sawada, Tsuyoshi "Properties of molecular gas in galaxies in early and mid stages of Interaction. III. Resolved Kennicutt-Schmidt law," *Publications of the Astronomical Society of Japan*, 74: 343, 2022.
- Kao, Melodie M.; Sebastian Pineda, J. "Radio Emission from Binary Ultracool Dwarf Systems," *The Astrophysical Journal*, 932: 21, 2022.
- Karachentsev, Igor D.; Cannon, John M.; Fuson, Jackson; Inoue, John L.; Tully, R. Brent; Anand, Gagandeep S.; Kaisin, Serafim S. "KK 242, A Faint Companion to the Isolated Scd Galaxy NGC 6503," *The Astronomical Journal*, 163: 51, 2022.
- Karas, Vladimír; Zajaček, Michal; Kunneriath, Devaky; Dovčiak, Michal "Electromagnetic signatures of strong-field gravity from accreting black-holes," *Advances in Space Research*, 69: 448, 2022.
- Karunakaran, Ananthan; Spekkens, Kristine; Carroll, Rhys; Sand, David J.; Bennet, Paul; Crnojević, Denija; Jones, Michael G.; Mutlu-Pakdil, Burçin "HI properties of satellite galaxies around local volume hosts," *Monthly Notices of the Royal Astronomical Society*, 516: 1741, 2022.
- Kastner, Joel H.; Moraga Baez, Paula; Balick, Bruce; Bublitz, Jesse; Montez, Rodolfo; Frank, Adam; Blackman, Eric "Panchromatic HST/WFC3 Imaging Studies of Young, Rapidly Evolving Planetary Nebulae. I. NGC 6302," *The Astrophysical Journal*, 927: 100, 2022.
- Kauffmann, Guinevere; Maraston, Claudia; Comparat, Johan; Crowther, Paul "A study of 1000 galaxies with unusually young and massive stars in the SDSS: a search for hidden black holes," *Monthly Notices of the Royal Astronomical Society*, 513: 1063, 2022.
- Kaur, B.; Kanekar, N.; Rafelski, M.; Neeleman, M.; Prochaska, J. X.; Revalski, M. "Jansky Very Large Array Detections of CO(1-0) Emission in H I-absorption-selected Galaxies at  $z \sim 2$ ," *The Astrophysical Journal*, 933: L42, 2022.
- Kaur, B.; Kanekar, N.; Revalski, M.; Rafelski, M.; Neeleman, M.; Prochaska, J. X.; Walter, F. "A Massive, Dusty, HI Absorption-Selected Galaxy at  $z = 2.46$  Identified in a CO Emission Survey," *The Astrophysical Journal*, 934: 87, 2022.
- Kawamuro, Taiki; Ricci, Claudio; Imanishi, Masatoshi; Mushotzky, Richard F.; Izumi, Takuma; Ricci, Federica; Bauer, Franz E.; Koss, Michael J.; Trakhtenbrot, Benny; Ichikawa, Kohei; Rojas, Alejandra F.; Smith, Krista Lynne; Shimizu, Tarō; Oh, Kyuseok; Den Brok, Jakob S.; Baba, Shunsuke; Baloković, Mislav; Chang, Chin-Shin; Kakkad, Darshan; Pfeifle, Ryan W.; Privon, George C.; Temple, Matthew J.; Ueda, Yoshihiro; Harrison, Fiona; Powell, Meredith C.; Stern, Daniel; Urry, Meg; Sanders, David B. "BASS XXXII: Studying the Nuclear Millimeter-wave Continuum Emission of AGNs with ALMA at Scales  $\sim 100$ -200 pc," *The Astrophysical Journal*, 938: 87, 2022.
- Kawana, Yuka; Saito, Toshiki; Okumura, Sachiko K.; Kawabe, Ryohei; Espada, Daniel; Iono, Daisuke; Kaneko, Hiroyuki; Lee, Minju M.; Michiyama, Tomonari; Motohara, Kentaro; Nakanishi, Kouichiro; Pettitt, Alex R.; Randriamanakoto, Zaza; Ueda, Junko; Yamashita, Takuji "Multiwavelength and Multi-CO View of the Minor Merger Driven Star Formation in the Nearby LIRG NGC 3110," *The Astrophysical Journal*, 929: 100, 2022.
- Kayal, Abhijit; Singh, Veeresh; Chandra, C. H. Ishwara; Wadadekar, Yogesh; Dutta, Sushant "Detection of radio-AGN in dust-obscured galaxies using deep uGMRT radio continuum observations," *Journal of Astrophysics and Astronomy*, 43: 84, 2022.
- Keller, Aya; O'Brien, Sean; Kamdar, Adyant; Rapidis, Nicholas M.; Leder, Alexander F.; Van Bibber, Karl "A Model-independent Radio Telescope Dark Matter Search," *The Astrophysical Journal*, 927: 71, 2022.
- Kervella, Pierre; Borgniet, Simon; Domiciano De Souza, Armando; Mérand, Antoine; Gallenne, Alexandre; Rivinius, Thomas; Lacour, Sylvestre; Carciofi, Alex; Faes, Daniel Moser; Le Bouquin, Jean-Baptiste; Taormina, Monica; Pilecki, Bogumił; Berger, Jean-Philippe; Bendjoya, Philippe; Klement, Robert; Millour, Florentin; Janot-Pacheco, Eduardo; Spang, Alain; Vakili, Farrokh "The binary system of the spinning-top Be star Achernar," *Astronomy and Astrophysics*, 667: A111, 2022.
- Khouri, Theo; Vlemmings, Wouter H. T.; Tafaya, Daniel; Pérez-Sánchez, Andrés F.; Sánchez Contreras, Carmen; Gómez, José F.; Imai, Hiroshi; Sahai, Raghvendra "Observational identification of a sample of likely recent common-envelope events," *Nature Astronomy*, 6: 275, 2022.
- Khusanova, Y.; Bañados, E.; Mazzucchelli, C.; Rojas-Ruiz, S.; Momjian, E.; Walter, F.; Decarli, R.; Venemans, B.; Farina, E. P.; Meyer, R.; Wang, F.; Yang, J. "The [CII] and FIR properties of  $z > 6$  radio-loud quasars," *Astronomy and Astrophysics*, 664: A39, 2022.
- Kim, Changseok; Woo, Jong-Hak; Jadhav, Yashashree; Chung, Aeree; Baek, Junhyun; Lee, Jeong Ae; Shin, Jaemin; Hwang, Ho Seong; Luo, Rongxin; Son, Donghoo; Kim, Hyungi; Woo, Hyuk "Determining Star Formation Rates of Active Galactic Nucleus Host Galaxies Based on SED Fitting with Submillimeter Data," *The Astrophysical Journal*, 928: 73, 2022.

## APPENDIX A: PUBLICATIONS

- Kim, D.-C.; Kim, Minjin; Yoon, Ilsang; Momjian, E.; Kim, Ji Hoon; Letai, J.; Evans, A. S. "Adaptive optics and VLBA imaging observations of recoiling supermassive black hole candidates," *Monthly Notices of the Royal Astronomical Society*, 517: 4081, 2022.
- Kim, Dae-Won; Kravchenko, Evgeniya V.; Kutkin, Alexander M.; Böttcher, Markus; Gómez, José L.; Gurwell, Mark; Jorstad, Svetlana G.; Lähteenmäki, Anne; Marscher, Alan P.; Ramakrishnan, Venkatesh; Tornikoski, Merja; Trippe, Sascha; Weaver, Zachary; Williamson, Karen E. "Radio and  $\gamma$ -Ray Activity in the Jet of the Blazar S5 0716+714," *The Astrophysical Journal*, 925: 64, 2022.
- Kim, Honggeun; Nhan, Bang D.; Hewitt, Jacqueline N.; Kern, Nicholas S.; Dillon, Joshua S.; De Lera Acedo, Eloy; Dynes, Scott B. C.; Mahesh, Nivedita; Fagnoni, Nicolas; Deboer, David R. "The Impact of Beam Variations on Power Spectrum Estimation for 21 cm Cosmology. I. Simulations of Foreground Contamination for HERA," *The Astrophysical Journal*, 941: 207, 2022.
- Kim, Jaeyeon; Chevance, Mélanie; Krujissen, J. M. Diederik; Leroy, Adam K.; Schruha, Andreas; Barnes, Ashley T.; Bigiel, Frank; Blanc, Guillermo A.; Cao, Yixian; Congiu, Enrico; Dale, Daniel A.; Faesi, Christopher M.; Glover, Simon C. O.; Grasha, Kathryn; Groves, Brent; Hughes, Annie; Klessen, Ralf S.; Kreckel, Kathryn; Mcelroy, Rebecca; Pan, Hsi-An; Pety, Jérôme; Querejeta, Miguel; Razza, Alessandro; Rosolowsky, Erik; Saito, Toshiki; Schinnerer, Eva; Sun, Jiayi; Tomičić, Neven; Usero, Antonio; Williams, Thomas G. "Environmental dependence of the molecular cloud lifecycle in 54 main-sequence galaxies," *Monthly Notices of the Royal Astronomical Society*, 516: 3006, 2022.
- Kim, Sang-Hyun; Lee, Sang-Sung; Lee, Jee Won; Hodgson, Jeffrey A.; Kang, Sincheol; Algaba, Juan-Carlos; Kim, Jae-Young; Hodges, Mark; Agudo, Ivan; Fuentes, Antonio; Escudero, Juan; Myserlis, Ioannis; Traianou, Efthalia; Lähteenmäki, Anne; Tornikoski, Merja; Tammi, Joni; Ramakrishnan, Venkatesh; Järvelä, Emilia "Magnetic field strengths of the synchrotron self-absorption region in the jet of CTA 102 during radio flares," *Monthly Notices of the Royal Astronomical Society*, 510: 815, 2022.
- Kirsten, F.; Marcote, B.; Nimmo, K.; Hessels, J. W. T.; Bhardwaj, M.; Tendulkar, S. P.; Keimpema, A.; Yang, J.; Snelders, M. P.; Scholz, P.; Pearlman, A. B.; Law, C. J.; Peters, W. M.; Giroletti, M.; Paragi, Z.; Bassa, C.; Hewitt, D. M.; Bach, U.; Bezrukovs, V.; Burgay, M.; Buttaccio, S. T.; Conway, J. E.; Corongiu, A.; Feiler, R.; Forssén, O.; Gawroński, M. P.; Karuppusamy, R.; Kharinov, M. A.; Lindqvist, M.; Maccaferri, G.; Melnikov, A.; Ould-Boukattine, O. S.; Possenti, A.; Surcis, G.; Wang, N.; Yuan, J.; Aggarwal, K.; Anna-Thomas, R.; Bower, G. C.; Blaauw, R.; Burke-Spolaor, S.; Cassanelli, T.; Clarke, T. E.; Fonseca, E.; Gaensler, B. M.; Gopinath, A.; Kaspi, V. M.; Kassim, N.; Lazio, T. J. W.; Leung, C.; Li, D. Z.; Lin, H. H.; Masui, K. W.; Mckinven, R.; Michilli, D.; Mikhailov, A. G.; Ng, C.; Orbidans, A.; Pen, U. L.; Petroff, E.; Rahman, M.; Ransom, S. M.; Shin, K.; Smith, K. M.; Stairs, I. H.; Vlemmings, W. "A repeating fast radio burst source in a globular cluster," *Nature*, 602: 585, 2022.
- Kisiel, Z.; Kolesniková, L.; Belloche, A.; Guillemin, J.-C.; Pszczołkowski, L.; Alonso, E. R.; Garrod, R. T.; Białkowska-Jaworska, E.; León, I.; Müller, H. S. P.; Menten, K. M.; Alonso, J. L. "Millimetre-wave laboratory study of glycinamide and a search for it with ALMA towards Sagittarius B2(N)," *Astronomy and Astrophysics*, 657: A99, 2022.
- Klitsch, A.; Christensen, L.; Valentino, F.; Kanekar, N.; Møller, P.; Zwaan, M. A.; Fynbo, J. P. U.; Neeleman, M.; Prochaska, J. X. "CO excitation and line energy distributions in gas-selected galaxies," *Monthly Notices of the Royal Astronomical Society*, 514: 2346, 2022.
- Knowles, K.; Cotton, W. D.; Rudnick, L.; Camilo, F.; Goedhart, S.; Deane, R.; Ramatsoku, M.; Bietenholz, M. F.; Brügggen, M.; Button, C.; Chen, H.; Chibueze, J. O.; Clarke, T. E.; De Gasperin, F.; Ianjamasimanana, R.; Józsa, G. I. G.; Hilton, M.; Kesebonye, K. C.; Kolokythas, K.; Kraan-Korteweg, R. C.; Lawrie, G.; Lochner, M.; Loubser, S. I.; Marchegiani, P.; Mhlahlo, N.; Moodley, K.; Murphy, E.; Namumba, B.; Oozeer, N.; Parekh, V.; Pillay, D. S.; Passmoor, S. S.; Ramaila, A. J. T.; Ranchod, S.; Retana-Montenegro, E.; Sebokolodi, L.; Sikhosana, S. P.; Smirnov, O.; Thorat, K.; Venturi, T.; Abbott, T. D.; Adam, R. M.; Adams, G.; Aldera, M. A.; Bauermeister, E. F.; Bennett, T. G. H.; Bode, W. A.; Botha, D. H.; Botha, A. G.; Brederode, L. R. S.; Buchner, S.; Burger, J. P.; Cheetham, T.; De Villiers, D. I. L.; Dikgale-Mahlakoana, M. A.; Du Toit, L. J.; Esterhuysen, S. W. P.; Fadana, G.; Fanaroff, B. L.; Fataar, S.; Foley, A. R.; Fourie, D. J.; Frank, B. S.; Gamatham, R. R. G.; Gatsi, T. G.; Geyer, M.; Gouws, M.; Gumede, S. C.; Heywood, I.; Hlakola, M. J.; Hokwana, A.; Hoosen, S. W.; Horn, D. M.; Horrell, J. M. G.; Hugo, B. V.; Isaacson, A. R.; Jonas, J. L.; Jordaan, J. D. B.; Joubert, A. F.; Julie, R. P. M.; Kapp, F. B.; Kasper, V. A.; Kenyon, J. S.; Kotzé, P. P. A.; Kotze, A. G.; Kriek, N.; Kriel, H.; Krishnan, V. K.; Kusel, T. W.; Legodi, L. S.; Lehmensiek, R.; Liebenberg, D.; Lord, R. T.; Lunsky, B. M.; Madisa, K.; Magnus, L. G.; Main, J. P. L.; Makhaba, A.; Makhathini, S.; Malan, J. A.; Manley, J. R.; Marais, S. J.; Maree, M. D. J.; Martens, A.; Mauch, T.; Mcalpine, K.; Merry, B. C.; Millenaar, R. P.; Mokone, O. J.; Monama, T. E.; Mphogo, M. C.; New, W. S.; Ngcebethsha, B.; Ngoasheng, K. J.; Ockards, M. T.; Otto, A. J.; Patel, A. A.; Peens-Hough, A.; Perkins, S. J.; Ramanujam, N. M.; Ramudzuli, Z. R.; Ratcliffe, S. M.; Renil, R.; Robyntjies, A.; Rust, A. N.; Salie, S.; Sambu, N.; Schollar, C. T. G.; Schwarzd, L. C.; Schwartz, R. L.; Serylak, M.; Siebrits, R.; Sirothia, S. K.; Slabber, M.; Sofeya, L.; Taljaard, B.; Tasse, C.; Tiplady, A. J.; Toruvanda, O.; Twum, S. N.; Van Balla, T. J.; Van Der Byl, A.; Van Der Merwe, C.; Van Dyk, C. L.; Van Tonder, V.; Van Wyk, R.; Venter, A. J.; Venter, M.; Welz, M. G.; Williams, L. P.; Xia, B. "The MeerKAT Galaxy Cluster Legacy Survey. I. Survey Overview and Highlights," *Astronomy and Astrophysics*, 657: A56, 2022.
- Kobelski, Adam R.; Tarr, Lucas A.; Jaeggli, Sarah A.; Luber, Nicholas; Warren, Harry P.; Savage, Sabrina "A Publicly Available Multiobservatory Data Set of an Enhanced Network Patch from the Photosphere to the Corona," *The Astrophysical Journal Supplement Series*, 261: 15, 2022.
- Koch, Patrick M.; Tang, Ya-Wen; Ho, Paul T. P.; Hsieh, Pei-Ying; Wang, Jia-Wei; Yen, Hsi-Wei; Duarte-Cabral, Ana; Peretto, Nicolas; Su, Yu-Nung "A Multiscale Picture of the Magnetic Field and Gravity from a Large-scale Filamentary Envelope to Core-accreting Dust Lanes in the High-mass Star-forming Region W51," *The Astrophysical Journal*, 940: 89, 2022.
- Koda, Jin; Watson, Linda; Combes, Françoise; Rubio, Monica; Boissier, Samuel; Yagi, Masafumi; Thilker, David; Lee, Amanda M.; Komiya, Yutaka; Morokuma-Matsui, Kana; Verdugo, Celia "First Detection of the Molecular Cloud Population in the Extended Ultraviolet Disk of M83," *The Astrophysical Journal*, 941: 3, 2022.
- Kokorev, V.; Brammer, G.; Fujimoto, S.; Kohno, K.; Magdis, G. E.; Valentino, F.; Toft, S.; Oesch, P.; Davidzon, I.; Bauer, F. E.; Coe, D.; Egami, E.; Oguri, M.; Ouchi, M.; Postman, M.; Richard, J.; Jolly, J.-B.; Knudsen, K. K.; Sun, F.; Weaver, J. R.; Ao, Y.; Baker, A. J.; Bradley, L.; Caputi, K. I.; Dessauges-Zavadsky, M.; Espada, D.; Hatsukade, B.; Koekemoer, A. M.; Muñoz Arancibia, A. M.; Shimasaku, K.; Umehata, H.; Wang, T.; Wang, W.-H. "ALMA Lensing Cluster Survey: Hubble Space Telescope and Spitzer Photometry of 33 Lensed Fields Built with CHARGE," *The Astrophysical Journal Supplement Series*, 263: 38, 2022.
- Kolesniková, L.; Belloche, A.; Koucký, J.; Alonso, E. R.; Garrod, R. T.; Luková, K.; Menten, K. M.; Müller, H. S. P.; Kania, P.; Urban, Š. "Laboratory rotational spectroscopy of acrylamide and a search for acrylamide and propionamide toward Sgr B2(N) with ALMA," *Astronomy and Astrophysics*, 659: A111, 2022.
- Koley, Atanu; Roy, Nirupam; Momjian, Emmanuel; Sarma, Anuj P.; Datta, Abhirup "Magnetic field measurement in TMC-1C using 22.3 GHz CCS Zeeman splitting," *Monthly Notices of the Royal Astronomical Society*, 516: L48, 2022.
- Kolokythas, Konstantinos; Vaddi, Sravani; O'Sullivan, Ewan; Loubser, Ilani; Babul, Arif; Raychaudhury, Somak; Lagos, Patricia; Jarrett, Thomas H. "The Complete Local-Volume Groups Sample - IV. Star formation and gas content in group-dominant galaxies," *Monthly Notices of the Royal Astronomical Society*, 510: 4191, 2022.
- Komugi, Shinya; Toba, Yoshiaki; Matsuoka, Yoshiaki; Saito, Toshiki; Yamashita, Takuji "Detection of Extended Millimeter Emission in the Host Galaxy of 3C 273 and Its Implications for QSO Feedback via High Dynamic Range

- ALMA Imaging," *The Astrophysical Journal*, 930: 3, 2022.
- Konishi, R.; Enokiya, R.; Fukui, Y.; Muraoka, K.; Tokuda, K.; Onishi, T. "Discovery of a Giant Molecular Loop in the Central Region of NGC 253," *The Astrophysical Journal*, 929: 63, 2022.
- Koptelova, Ekaterina; Hwang, Chong-Yuan "A BL Lacertae Object at a Cosmic Age of 800 Myr," *The Astrophysical Journal*, 929: L7, 2022.
- Koryukova, T. A.; Pushkarev, A. B.; Plavin, A. V.; Kovalev, Y. Y. "Tracing Milky Way scattering by compact extragalactic radio sources," *Monthly Notices of the Royal Astronomical Society*, 515: 1736, 2022.
- Kosogorov, N. A.; Kovalev, Y. Y.; Perucho, M.; Kovalev, Yu A. "Parsec-scale properties of the peculiar gigahertz-peaked spectrum quasar 0858-279," *Monthly Notices of the Royal Astronomical Society*, 510: 1480, 2022.
- Koss, Michael J.; Ricci, Claudio; Trakhtenbrot, Benny; Oh, Kyuseok; Den Brok, Jakob S.; Mejía-Restrepo, Julian E.; Stern, Daniel; Privon, George C.; Treister, Ezequiel; Powell, Meredith C.; Mushotzky, Richard; Bauer, Franz E.; Ananna, Tonima T.; Baloković, Mislav; Bär, Rudolf E.; Becker, George; Bessiere, Patricia; Burtscher, Leonard; Caglar, Turgay; Congiu, Enrico; Evans, Phil; Harrison, Fiona; Heida, Marianne; Ichikawa, Kohei; Kamraj, Nikita; Lamperti, Isabella; Pacucci, Fabio; Ricci, Federica; Riffel, Rogério; Rojas, Alejandra F.; Schawinski, Kevin; Temple, Matthew J.; Urry, C. Megan; Veilleux, Sylvain; Williams, Jonathan "BASS. XXII. The BASS DR2 AGN Catalog and Data," *The Astrophysical Journal Supplement Series*, 261: 2, 2022.
- Koss, Michael J.; Trakhtenbrot, Benny; Ricci, Claudio; Bauer, Franz E.; Treister, Ezequiel; Mushotzky, Richard; Urry, C. Megan; Ananna, Tonima T.; Baloković, Mislav; Den Brok, Jakob S.; Cenko, S. Bradley; Harrison, Fiona; Ichikawa, Kohei; Lamperti, Isabella; Lein, Amy; Mejía-Restrepo, Julian E.; Oh, Kyuseok; Pacucci, Fabio; Pfeifle, Ryan W.; Powell, Meredith C.; Privon, George C.; Ricci, Federica; Salvato, Mara; Schawinski, Kevin; Shimizu, Taro; Smith, Krista L.; Stern, Daniel "BASS. XXI. The Data Release 2 Overview," *The Astrophysical Journal Supplement Series*, 261: 1, 2022.
- Koss, Michael J.; Trakhtenbrot, Benny; Ricci, Claudio; Oh, Kyuseok; Bauer, Franz E.; Stern, Daniel; Caglar, Turgay; Den Brok, Jakob S.; Mushotzky, Richard; Ricci, Federica; Mejía-Restrepo, Julian E.; Lamperti, Isabella; Treister, Ezequiel; Bär, Rudolf E.; Harrison, Fiona; Powell, Meredith C.; Privon, George C.; Riffel, Rogério; Rojas, Alejandra F.; Schawinski, Kevin; Urry, C. Megan "BASS. XXVI. DR2 Host Galaxy Stellar Velocity Dispersions," *The Astrophysical Journal Supplement Series*, 261: 6, 2022.
- Koucký, J.; Kolesníková, L.; Luková, K.; Vávra, K.; Kania, P.; Coutens, A.; Loison, J.-C.; Jørgensen, J. K.; Belloche, A.; Urban, Š. "Millimetre-wave spectroscopy of 2-hydroxyprop-2-enal and an astronomical search with ALMA," *Astronomy and Astrophysics*, 666: A158, 2022.
- Kovačević, Anđjelka B.; Radović, Viktor; Ilić, Dragana; Popović, Luka Č.; Assef, Roberto J.; Sánchez-Sáez, Paula; Nikutta, Robert; Raiteri, Claudia M.; Yoon, Ilsang; Homayouni, Yasaman; Li, Yan-Rong; Caplar, Neven; Czerny, Bozena; Panda, Swayamtrupta; Ricci, Claudio; Jankov, Isidora; Landt, Hermine; Wolf, Christian; Kovačević-Dojčinović, Jelena; Lakićević, Maša; Savić, Đorđe V.; Vince, Oliver; Simić, Saša; Čvorović-Hajdinjak, Iva; Marčeta-Mandić, Sladjana "The LSST Era of Supermassive Black Hole Accretion Disk Reverberation Mapping," *The Astrophysical Journal Supplement Series*, 262: 49, 2022.
- Kramarenko, I. G.; Pushkarev, A. B.; Kovalev, Y. Y.; Lister, M. L.; Hovatta, T.; Savolainen, T. "A decade of joint MOJAVE-Fermi AGN monitoring: localization of the gamma-ray emission region," *Monthly Notices of the Royal Astronomical Society*, 510: 469, 2022.
- Kremer, Kyle; Ye, Claire S.; Kiroğlu, Fulya; Lombardi, James C.; Ransom, Scott M.; Rasio, Frederic A. "Formation of Low-mass Black Holes and Single Millisecond Pulsars in Globular Clusters," *The Astrophysical Journal*, 934: L1, 2022.
- Kubo, Mariko; Umehata, Hideki; Matsuda, Yuichi; Kajisawa, Masaru; Steidel, Charles C.; Yamada, Toru; Tanaka, Ichi; Hatsukade, Bunyo; Tamura, Yoichi; Nakanishi, Kouichiro; Kohno, Kotaro; Lee, Kianhong; Matsuda, Keiichi; Ao, Yiping; Nagao, Tohru; Yun, Min S. "An AGN with an Ionized Gas Outflow in a Massive Quiescent Galaxy in a Protocluster at  $z = 3.09$ ," *The Astrophysical Journal*, 935: 89, 2022.
- Kulkarni, Varsha P.; Bowen, David V.; Straka, Lorrie A.; York, Donald G.; Gupta, Neeraj; Noterdaeme, Pasquier; Srikanth, Raghunathan "Damped Ly $\alpha$  Absorbers in Star-forming Galaxies at  $z < 0.15$  Detected with the Hubble Space Telescope and Implications for Galactic Evolution," *The Astrophysical Journal*, 929: 150, 2022.
- Kumar, Vipin; Vig, S.; Veena, V. S.; Mohan, S.; Ghosh, S. K.; Tej, A.; Ojha, D. K. "Investigating star-formation activity towards the southern H II region RCW 42," *Monthly Notices of the Royal Astronomical Society*, 515: 5730, 2022.
- Kumari, Shobha; Pal, Sabyasachi "Search for hybrid morphology radio galaxies from the FIRST survey at 1400 MHz," *Monthly Notices of the Royal Astronomical Society*, 514: 4290, 2022.
- Kun, Emma; Bartos, Imre; Becker Tjus, Julia; Biermann, Peter L.; Franckowiak, Anna; Halzen, Francis "Multiwavelength Search for the Origin of IceCube's Neutrinos," *The Astrophysical Journal*, 934: 180, 2022.
- Kun, Emma; Jaroschewski, Ilja; Ghorbanietamad, Armin; Frey, Sándor; Becker Tjus, Julia; Britzen, Silke; Gabányi, Krisztina Éva; Kiselev, Vladimir; Schlegel, Leander; Schroller, Marcel; Reichherzer, Patrick; Cui, Lang; Wang, Xin; Shen, Yuling "Multimessenger Picture of J1048+7143," *The Astrophysical Journal*, 940: 163, 2022.
- Kuo, I. -Hsuan Genevieve; Yen, Hsi-Wei; Gu, Pin-Gao; Chang, Tze-En "Kinematical Constraint on Eccentricity in the Protoplanetary Disk MWC 758 with ALMA," *The Astrophysical Journal*, 938: 50, 2022.
- Kurtovic, N. T.; Pinilla, P.; Penzlin, Anna B. T.; Benisty, M.; Pérez, L.; Ginski, C.; Isella, A.; Kley, W.; Menard, F.; Pérez, S.; Bayo, A. "The morphology of CS Cha circumbinary disk suggesting the existence of a Saturn-mass planet," *Astronomy and Astrophysics*, 664: A151, 2022.
- Kwon, Woojin; Pattle, Kate; Sadavoy, Sarah; Hull, Charles L. H.; Johnstone, Doug; Ward-Thompson, Derek; Francesco, James Di; Koch, Patrick M.; Furuya, Ray; Doi, Yasuo; Le Gouellec, Valentin J. M.; Hwang, Jihye; Lyo, A. -Ran; Soam, Archana; Tang, Xindi; Hoang, Thiem; Kirchschrager, Florian; Eswaraiah, Chakali; Fanciullo, Lapo; Kim, Kyoung Hee; Onaka, Takashi; Könyves, Vera; Kang, Ji-Hyun; Lee, Chang Won; Tamura, Motohide; Bastien, Pierre; Hasegawa, Tetsuo; Lai, Shih-Ping; Qiu, Keping; Berry, David; Arzoumanian, Doris; Bourke, Tyler L.; Byun, Do-Young; Chen, Wen Ping; Chen, Hui-Ru Vivien; Chen, Mike; Chen, Zhiwei; Ching, Tao-Chung; Cho, Jungyeon; Choi, Yunhee; Choi, Minho; Chrysostomou, Antonio; Chung, Eun Jung; Coudé, Simon; Dai, Sophia; Diep, Pham Ngoc; Duan, Yan; Duan, Hao-Yuan; Eden, David; Fiege, Jason; Fissel, Laura M.; Franzmann, Erica; Friberg, Per; Friesen, Rachel; Fuller, Gary; Gledhill, Tim; Graves, Sarah; Greaves, Jane; Griffin, Matt; Gu, Qilao; Han, Ilseung; Hatchell, Jennifer; Hayashi, Saeko; Houde, Martin; Inoue, Tsuyoshi; Inutsuka, Shu-Ichiro; Iwasaki, Kazunari; Jeong, Il-Gyo; Kang, Miju; Karoly, Janik; Kataoka, Akimasa; Kawabata, Koji; Kemper, Francisca; Kim, Kee-Tae; Kim, Gwanjeong; Kim, Mi-Ryang; Kim, Shinyoung; Kim, Jongsoo; Kirk, Jason; Kobayashi, Masato I. N.; Kusune, Takayoshi; Kwon, Jungmi; Lacaille, Kevin; Law, Chi-Yan; Lee, Chin-Fei; Lee, Yong-Hee; Lee, Hyesung; Lee, Jeong-Eun; Lee, Sang-Sung; Li, Dalei; Li, Di; Li, Hua-Bai; Lin, Sheng-Jun; Liu, Sheng-Yuan; Liu, Hong-Li; Liu, Junhao; Liu, Tie; Lu, Xing; Mairs, Steve; Matsumura, Masafumi; Matthews, Brenda; Moriarty-Schieven, Gerald; Nagata, Tetsuya; Nakamura, Fumitaka; Nakanishi, Hiroyuki; Ngoc, Nguyen Bich; Ohashi, Nagayoshi; Park, Geumsook; Parsons, Harriet; Peretto, Nicolas; Priestley, Felix; Pyo, Tae-Soo; Qian, Lei; Rao, Ramprasad; Rawlings, Jonathan; Rawlings, Mark G.; Retter, Brendan; Richer, John; Rigby, Andrew; Saito, Hiro; Savini, Giorgio; Seta, Masumichi; Shimajiri, Yoshito; Shinnaga, Hiroko; Tahani, Mehmoosh; Tang, Ya-Wen; Tomisaka, Kohji; Tram, Le Ngoc; Tsukamoto, Yusuke; Viti, Serena; Wang, Hongchi; Wang, Jia-Wei; Whitworth, Anthony; Wu, Jintai; Xie, Jinjin; Yen, Hsi-Wei; Yoo, Hyunju; Yuan, Jinghua; Yun, Hyeong-Sik; Zenko, Tetsuya; Zhang, Yapeng; Zhang, Chuan-Peng; Zhang, Guoyin; Zhou, Jianjun; Zhu, Lei;

## APPENDIX A: PUBLICATIONS

- Looze, Ilse De; André, Philippe; Dowell, C. Darren; Eyres, Stewart; Falle, Sam; Robitaille, Jean-François; Loo, Sven Van "B-fields in Star-forming Region Observations (BISTRO): Magnetic Fields in the Filamentary Structures of Serpens Main," *The Astrophysical Journal*, 926: 163, 2022.
- Labrosse, Nicolas; Rodger, Andrew S.; Radziszewski, Krzysztof; Rudawy, Pawel; Antolin, Patrick; Fletcher, Lyndsay; Levens, Peter J.; Peat, Aaron W.; Schmieder, Brigitte; Simões, Paulo J. A. "First high resolution interferometric observation of a solar prominence with ALMA," *Monthly Notices of the Royal Astronomical Society*, 513: L30, 2022.
- Ladeyshchikov, D. A.; Tsvilev, A. P.; Sobolev, A. M.; Popova, E. A. "Search for Bright Masers in the Water Vapor Line towards the Dust Clumps of the Galaxy," *Astronomy Reports*, 66: 278, 2022.
- Lai, Thomas S.-Y.; Armus, Lee; U, Vivian; Díaz-Santos, Tanio; Larson, Kirsten L.; Evans, Aaron; Malkan, Matthew A.; Appleton, Philip; Rich, Jeff; Müller-Sánchez, Francisco; Inami, Hanae; Bohn, Thomas; McKinney, Jed; Finnerty, Luke; Law, David R.; Linden, Sean T.; Medling, Anne M.; Privon, George C.; Song, Yiqing; Stierwalt, Sabrina; Van Der Werf, Paul P.; Barcos-Muñoz, Loreto; Smith, J. D. T.; Togi, Aditya; Aalto, Susanne; Böker, Torsten; Charmandaris, Vassilis; Howell, Justin; Iwasawa, Kazushi; Kemper, Francisca; Mazzarella, Joseph M.; Murphy, Eric J.; Brown, Michael J. I.; Hayward, Christopher C.; Marshall, Jason; Sanders, David; Surace, Jason "GOALS-JWST: Tracing AGN Feedback on the Star-forming Interstellar Medium in NGC 7469," *The Astrophysical Journal*, 941: L36, 2022.
- Lamarque, C.; Smith, J. D.; Kreckel, K.; Linden, S. T.; Rogers, N. S. J.; Skillman, E.; Berg, D.; Murphy, E.; Pogge, R.; Donnelly, G. P.; Kennicutt, R.; Bolatto, A.; Croxall, K.; Groves, B.; Ferkinhoff, C. "Direct Far-infrared Metal Abundances (FIRA). I. M101," *The Astrophysical Journal*, 925: 194, 2022.
- Lamperti, I.; Pereira-Santaella, M.; Perna, M.; Colina, L.; Arribas, S.; García-Burillo, S.; González-Alfonso, E.; Aalto, S.; Alonso-Herrero, A.; Combes, F.; Labiano, A.; Piqueras-López, J.; Rigopoulou, D.; Van Der Werf, P. "Physics of ULIRGs with MUSE and ALMA: The PUMA project. IV. No tight relation between cold molecular outflow rates and AGN luminosities," *Astronomy and Astrophysics*, 668: A45, 2022.
- Lanz, Lauranne; Stepanoff, Sofia; Hickox, Ryan C.; Alatalo, Katherine; French, K. Decker; Rowlands, Kate; Nyland, Kristina; Appleton, Philip N.; Lacy, Mark; Medling, Anne; Mulchaey, John S.; Sazonova, Elizaveta; Urry, Claudia Megan "Are Active Galactic Nuclei in Post-starburst Galaxies Driving the Change or Along for the Ride?," *The Astrophysical Journal*, 935: 29, 2022.
- Laskar, Tanmoy; Escorial, Alicia Rouco; Schroeder, Genevieve; Fong, Wen-Fai; Berger, Edo; Veres, Péter; Bhandari, Shivani; Rastinejad, Jillian; Kilpatrick, Charles D.; Tohuvavohu, Aaron; Margutti, Raffaella; Alexander, Kate D.; Delaunay, James; Kennea, Jamie A.; Nugent, Anya; Paterson, K.; Williams, Peter K. G. "The First Short GRB Millimeter Afterglow: The Wide-angled Jet of the Extremely Energetic SGRB 211106A," *The Astrophysical Journal*, 935: L11, 2022.
- Launhardt, Ralf; Loinard, Laurent; Dzib, Sergio A.; Forbrich, Jan; Bower, Geoffrey C.; Henning, Thomas K.; Mioduszewski, Amy J.; Reffert, Sabine "Nonthermal Radio Continuum Emission from Young Nearby Stars," *The Astrophysical Journal*, 931: 43, 2022.
- Law, Casey J.; Connor, Liam; Aggarwal, Kshitij "On the Fast Radio Burst and Persistent Radio Source Populations," *The Astrophysical Journal*, 927: 55, 2022.
- Law, Charles J.; Crystian, Sage; Teague, Richard; Öberg, Karin I.; Rich, Evan A.; Andrews, Sean M.; Bae, Jaehan; Flaherty, Kevin; Guzmán, Viviana V.; Huang, Jane; Ilee, John D.; Kastner, Joel H.; Loomis, Ryan A.; Long, Feng; Pérez, Laura M.; Pérez, Sebastián; Qi, Chunhua; Rosotti, Giovanni P.; Ruíz-Rodríguez, Dary; Tsukagoshi, Takashi; Wilner, David J. "CO Line Emission Surfaces and Vertical Structure in Midinclination Protoplanetary Disks," *The Astrophysical Journal*, 932: 114, 2022.
- Law, Chi-Yan; Tan, Jonathan C.; Gorai, Prasanta; Zhang, Yichen; Fedriani, Rubén; Tafuya, Daniel; Tanaka, Kei E. I.; Cosentino, Giuliana; Yang, Yao-Lun; Mardones, Diego; Beltrán, María T.; Garay, Guido "Isolated Massive Star Formation in G28.20-0.05," *The Astrophysical Journal*, 939: 120, 2022.
- Law, David R.; Belfiore, Francesco; Bershady, Matthew A.; Cappellari, Michele; Drory, Niv; Masters, Karen L.; Westfall, Kyle B.; Bizyaev, Dmitry; Bundy, Kevin; Pan, Kaike; Yan, Renbin "SDSS-IV MaNGA: Understanding Ionized Gas Turbulence Using Integral Field Spectroscopy of 4500 Star-forming Disk Galaxies," *The Astrophysical Journal*, 928: 58, 2022.
- Le Reste, Alexandra; Hayes, Matthew; Cannon, John M.; Herenz, Edmund Christian; Melinder, Jens; Menacho, Veronica; Östlin, Göran; Puschnig, Johannes; Rivera-Thorsen, T. Emil; Kunth, Daniel; Velikonja, Nick "LARS XIII: High Angular Resolution 21 cm H I Observations of Lya Emitting Galaxies," *The Astrophysical Journal*, 934: 69, 2022.
- Lee, Bumhyun; Wang, Jing; Chung, Aeree; Ho, Luis C.; Wang, Ran; Michiyama, Tomonari; Molina, Juan; Kim, Yongjung; Shao, Li; Kilborn, Virginia; Wang, Shun; Lin, Xuchen; Kim, Dawoon E.; Catinella, Barbara; Cortese, Luca; Deg, Nathan; Denes, Helga; Elagali, Ahmed; For, Bi-Qing; Kleiner, Dane; Koribalski, Bärbel S.; Lee-Waddell, Karen; Rhee, Jonghwan; Spekkens, Kristine; Westmeier, Tobias; Wong, O. Ivy; Bigiel, Frank; Bosma, Albert; Holwerda, Benne W.; Van Der Hulst, Jan M.; Roychowdhury, Sambit; Verdes-Montenegro, Lourdes; Zwaan, Martin A. "ALMA/ACA CO Survey of the IC 1459 and NGC 4636 Groups: Environmental Effects on the Molecular Gas of Group Galaxies," *The Astrophysical Journal Supplement Series*, 262: 31, 2022.
- Lee, Chin-Fei; Codella, Claudio; Ceccarelli, Cecilia; López-Sepulcre, Ana "Stratified Distribution of Organic Molecules at the Planet-formation Scale in the HH 212 Disk Atmosphere," *The Astrophysical Journal*, 937: 10, 2022.
- Lee, Chin-Fei; Li, Zhi-Yun; Shang, Hsien; Hirano, Naomi "Magnetocentrifugal Origin for Protostellar Jets Validated through Detection of Radial Flow at the Jet Base," *The Astrophysical Journal*, 927: L27, 2022.
- Lee, Janice C.; Whitmore, Bradley C.; Thilker, David A.; Deger, Sinan; Larson, Kirsten L.; Ubeda, Leonardo; Anand, Gagandeep S.; Boquien, Médéric; Chandar, Rupali; Dale, Daniel A.; Emsellem, Eric; Leroy, Adam K.; Rosolowsky, Erik; Schinnerer, Eva; Schmidt, Judy; Lilly, James; Turner, Jordan; Van Dyk, Schuyler; White, Richard L.; Barnes, Ashley T.; Belfiore, Francesco; Bigiel, Frank; Blanc, Guillermo A.; Cao, Yixian; Chevance, Melanie; Congiu, Enrico; Egorov, Oleg V.; Glover, Simon C. O.; Grasha, Kathryn; Groves, Brent; Henshaw, Jonathan D.; Hughes, Annie; Klessen, Ralf S.; Koch, Eric; Kreckel, Kathryn; Kruijssen, J. M. Diederik; Liu, Daizhong; Lopez, Laura A.; Mayker, Ness; Meidt, Sharon E.; Murphy, Eric J.; Pan, Hsi-An; Pety, Jérôme; Querejeta, Miguel; Razza, Alessandro; Saito, Toshiki; Sánchez-Blázquez, Patricia; Santoro, Francesco; Sardone, Amy; Scheuermann, Fabian; Schruba, Andreas; Sun, Jiayi; Usero, Antonio; Watkins, E.; Williams, Thomas G. "The PHANGS-HST Survey: Physics at High Angular Resolution in Nearby Galaxies with the Hubble Space Telescope," *The Astrophysical Journal Supplement Series*, 258: 10, 2022.
- Lee, K. H.; Bartos, I.; Eddins, A.; Corsi, A.; Márka, Z.; Privon, G. C.; Márka, S. "Radio Constraints on r-process Nucleosynthesis by Collapsars," *The Astrophysical Journal*, 934: L5, 2022.
- Leemker, M.; Booth, A. S.; Van Dishoeck, E. F.; Pérez-Sánchez, A. F.; Szulágyi, J.; Bosman, A. D.; Bruderer, S.; Facchini, S.; Hogerheijde, M. R.; Panque-Carreño, T.; Sturm, J. A. "Gas temperature structure across transition disk cavities," *Astronomy and Astrophysics*, 663: A23, 2022.
- Lelli, Federico; Davis, Timothy A.; Bureau, Martin; Cappellari, Michele; Liu, Lijie; Ruffa, Ilaria; Smith, Mark D.; Williams, Thomas G. "WISDOM Project - XIII. Feeding molecular gas to the supermassive black hole in the starburst AGN-host galaxy Fairall 49," *Monthly Notices of the Royal Astronomical Society*, 516: 4066, 2022.
- Lellouch, E.; Butler, B.; Moreno, R.; Gurwell, M.; Lavvas, P.; Bertrand, T.; Fouchet, T.; Strobel, D. F.; Moullet, A. "Pluto's atmosphere observations with ALMA: Spatially-resolved maps of CO and HCN emission and first detection of HNC," *Icarus*, 372: 114722, 2022.
- Lellouch, E.; Moreno, R.; Bockelée-Morvan, D.; Biver, N.; Santos-Sanz, P.

- "Size and albedo of the largest detected Oort-cloud object: Comet C/2014 UN271 (Bernardinelli-Bernstein)," *Astronomy and Astrophysics*, 659: L1, 2022.
- Leroy, Adam K.; Rosolowsky, Erik; Usero, Antonio; Sandstrom, Karin; Schinnerer, Eva; Schrubba, Andreas; Bolatto, Alberto D.; Sun, Jiayi; Barnes, Ashley T.; Belfiore, Francesco; Bigiel, Frank; Den Brok, Jakob S.; Cao, Yixian; Chiang, I. -Da; Chevance, Mélanie; Dale, Daniel A.; Eibensteiner, Cosima; Faesi, Christopher M.; Glover, Simon C. O.; Hughes, Annie; Jiménez Donaire, María J.; Klessen, Ralf S.; Koch, Eric W.; Kruijssen, J. M. Diederik; Liu, Daizhong; Meidt, Sharon E.; Pan, Hsi-An; Pety, Jérôme; Puschign, Johannes; Querejeta, Miguel; Saito, Toshiki; Sardone, Amy; Watkins, Elizabeth J.; Weiss, Axel; Williams, Thomas G. "Low-J CO Line Ratios from Single-dish CO Mapping Surveys and PHANGS-ALMA," *The Astrophysical Journal*, 927: 149, 2022.
- Levkov, D. G.; Panin, A. G.; Tkachev, I. I. "Propagation Effects in the FRB 20121102A Spectra," *The Astrophysical Journal*, 925: 109, 2022.
- Levy, Rebecca C.; Bolatto, Alberto D.; Leroy, Adam K.; Sormani, Mattia C.; Emig, Kimberly L.; Gorski, Mark; Lenkić, Laura; Mills, Elisabeth A. C.; Tarantino, Elizabeth; Teuben, Peter; Villeux, Sylvain; Walter, Fabian "The Morpho-kinematic Architecture of Super Star Clusters in the Center of NGC 253," *The Astrophysical Journal*, 935: 19, 2022.
- Lewandowska, N.; Demorest, P. B.; McLaughlin, M. A.; Kilian, P.; Hankins, T. H. "Single Pulse Dispersion Measure of the Crab Pulsar," *The Astrophysical Journal*, 935: 84, 2022.
- Li, J. J.; Immer, K.; Reid, M. J.; Sanna, A.; Rygl, K. L. J.; Xu, Y.; Zhang, B.; Brunthaler, A.; Menten, K. M. "Accurate Distances of Massive Young Stars in the Scutum Spiral Arm," *The Astrophysical Journal Supplement Series*, 262: 42, 2022.
- Li, Jianan; Venemans, Bram P.; Walter, Fabian; Decarli, Roberto; Wang, Ran; Cai, Zheng "Spatially Resolved Molecular Interstellar Medium in a  $z = 6.6$  Quasar Host Galaxy," *The Astrophysical Journal*, 930: 27, 2022.
- Li, Jian-Kang; Zhao, Hai-Chen; Tao, Zhen-Zhao; Zhang, Tong-Jie; Xiao-Hui, Sun "Drift Rates of Narrowband Signals in Long-term SETI Observations for Exoplanets," *The Astrophysical Journal*, 938: 1, 2022.
- Li, Shanghuo; Sanhueza, Patricio; Lee, Chang Won; Zhang, Qizhou; Beuther, Henrik; Palau, Aina; Liu, Hong-Li; Smith, Howard A.; Liu, Haiyu Baobab; Jiménez-Serra, Izaskun; Kim, Kee-Tae; Feng, Siyi; Liu, Tie; Wang, Junzhi; Li, Di; Qiu, Keping; Lu, Xing; Girart, Josep Miquel; Wang, Ke; Li, Fei; Li, Juan; Cao, Yue; Kim, Shinyoung; Strom, Shaye "ALMA Observations of NGC 6334S. II. Subsonic and Transonic Narrow Filaments in a High-mass Star Formation Cloud," *The Astrophysical Journal*, 926: 165, 2022.
- Li, Shanghuo; Sanhueza, Patricio; Lu, Xing; Lee, Chang Won; Zhang, Qizhou; Bovino, Stefano; Sabatini, Giovanni; Liu, Tie; Kim, Kee-Tae; Morii, Kaho; Tafuya, Daniel; Tatematsu, Ken'Ichi; Sakai, Takeshi; Wang, Junzhi; Li, Fei; Silva, Andrea; Izumi, Natsuko; Allingham, David "The ALMA Survey of 70  $\mu\text{m}$  Dark High-mass Clumps in Early Stages (ASHES). VII. Chemistry of Embedded Dense Cores," *The Astrophysical Journal*, 939: 102, 2022.
- Li, Yingjie; Xu, Ye; Li, Jingjing; Wu, Yuanwei; Bian, Shaibo; Lin, Zehao; Yang, Wenjin; Hao, Chaojie; Liu, Dejian "Light Deflection under the Gravitational Field of Jupiter-Testing General Relativity," *The Astrophysical Journal*, 925: 47, 2022.
- Liao, Mai; Wang, Junxian; Kang, Wenyong; Zhou, Minhua "Exploring the connection between ultraviolet/optical variations and radio emission in radio-quiet quasars: clues about the origin of radio emission," *Monthly Notices of the Royal Astronomical Society*, 512: 296, 2022.
- Lico, R.; Casadio, C.; Jorstad, S. G.; Gómez, J. L.; Marscher, A. P.; Traianou, E.; Kim, J.-Y.; Zhao, G.-Y.; Fuentes, A.; Cho, I.; Krichbaum, T. P.; Hervet, O.; O'Brien, S.; Boccasardi, B.; Myserlis, I.; Agudo, I.; Alberdi, A.; Weaver, Z. R.; Zensus, J. A. "New jet feature in the parsec-scale jet of the blazar OJ 287 connected to the 2017 teraelectronvolt flaring activity," *Astronomy and Astrophysics*, 658: L10, 2022.
- Ligterink, Niels F. W.; Ahmadi, Aida; Luitel, Bijaya; Coutens, Audrey; Calcutt, Hannah; Tychoniec, Łukasz; Linnartz, Harold; Jørgensen, Jes K.; Garrod, Robin T.; Bouwman, Jordy "The Prebiotic Molecular Inventory of Serpens SMM1: II. The Building Blocks of Peptide Chains," *ACS Earth and Space Chemistry*, 6: 455, 2022.
- Lin, Lihwai; Ellison, Sara L.; Pan, Hsi-An; Thorp, Mallory D.; Yu, Po-Chieh; Belfiore, Francesco; Hsieh, Bau-Ching; Maiolino, Roberto; Ramya, S.; Sánchez, Sebastián F.; Su, Yung-Chau "The ALMaQUEST Survey. VII. Star Formation Scaling Relations of Green Valley Galaxies," *The Astrophysical Journal*, 926: 175, 2022.
- Lin, Zhe-Yu Daniel; Li, Zhi-Yun; Yang, Haifeng; Stephens, Ian; Looney, Leslie; Harrison, Rachel; Fernández-López, Manuel "Thermal emission and scattering by aligned grains: Plane-parallel model and application to multiwavelength polarization of the HL Tau disc," *Monthly Notices of the Royal Astronomical Society*, 512: 3922, 2022.
- Ling, Chenxiaoj; Yan, Haojing "Morphological Evolution of the Hosts of Far-infrared/Submillimeter Galaxies," *The Astrophysical Journal*, 929: 40, 2022.
- Ling, Jason; Isella, Andrea; Johns-Krull, Christopher; Lazio, T. Joseph W. "Searching for Stellar and Planetary Emission in Large Field-of-view Radio Sky Surveys," *The Astrophysical Journal*, 926: 228, 2022.
- Litke, Katrina C.; Marrone, Daniel P.; Aravena, Manuel; Béthermin, Matthieu; Chapman, Scott C.; Dong, Chenxing; Hayward, Christopher C.; Hill, Ryley; Jarugula, Sreevani; Malkan, Matthew A.; Narayanan, Desika; Reuter, Cassie A.; Spilker, Justin S.; Sulzenauer, Nikolaus; Vieira, Joaquin D.; Weiß, Axel "Multiphase ISM in the  $z = 5.7$  Hyperluminous Starburst SPT 0346-52," *The Astrophysical Journal*, 928: 179, 2022.
- Liu, Bin; Chartab, N.; Nayyeri, H.; Cooray, A.; Yang, C.; Riechers, D. A.; Gurwell, M.; Zhu, Zong-Hong; Serjeant, S.; Borsato, E.; Negrello, M.; Marchetti, L.; Corsini, E. M.; Van Der Werf, P. "Massive Molecular Gas Reservoir in a Luminous Submillimeter Galaxy during Cosmic Noon," *The Astrophysical Journal*, 929: 41, 2022.
- Liu, Hong-Li; Tej, Anandmayee; Liu, Tie; Goldsmith, Paul F.; Stutz, Amelia; Juvela, Mika; Qin, Sheng-Li; Xu, Feng-Wei; Bronfman, Leonardo; Evans, Neal J.; Saha, Anindya; Issac, Namitha; Tatematsu, Ken'Ichi; Wang, Ke; Li, Shanghuo; Zhang, Siju; Baug, Tapas; Dewangan, Lokesh; Wu, Yue-Fang; Zhang, Yong; Lee, Chang Won; Liu, Xun-Chuan; Zhou, Jianwen; Soam, Archana "ATOMS: ALMA Three-millimeter Observations of Massive Star-forming regions - IX. A pilot study towards IRDC G034.43+00.24 on multi-scale structures and gas kinematics," *Monthly Notices of the Royal Astronomical Society*, 511: 4480, 2022.
- Liu, Hong-Li; Tej, Anandmayee; Liu, Tie; Issac, Namitha; Saha, Anindya; Goldsmith, Paul F.; Wang, Jun-Zhi; Zhang, Qizhou; Qin, Sheng-Li; Wang, Ke; Li, Shanghuo; Soam, Archana; Dewangan, Lokesh; Lee, Chang Won; Li, Pak-Shing; Liu, Xun-Chuan; Zhang, Yong; Ren, Zhiyuan; Juvela, Mika; Bronfman, Leonardo; Wu, Yue-Fang; Tatematsu, Ken'Ichi; Chen, Xi; Li, Di; Stutz, Amelia; Zhang, Siju; Toth, L. Viktor; Luo, Qiu-Yi; Xu, Feng-Wei; Li, Jinzeng; Liu, Rong; Zhou, Jianwen; Zhang, Chao; Tang, Mengyao; Zhang, Chao; Baug, Tapas; Mannfors, E.; Chakali, Eswaraiah; Dutta, Somnath "ATOMS: ALMA Three-millimeter Observations of Massive Star-forming regions - V. Hierarchical fragmentation and gas dynamics in IRDC G034.43+00.24," *Monthly Notices of the Royal Astronomical Society*, 510: 5009-5022, 2022.
- Liu, Lijie; Bureau, Martin; Li, Guang-Xing; Davis, Timothy A.; Nguyen, Dieu D.; Liang, Fu-Heng; Choi, Woorak; Smith, Mark R.; Iguchi, Satoru "WISDOM Project - XII. Clump properties and turbulence regulated by clump-clump collisions in the dwarf galaxy NGC 404," *Monthly Notices of the Royal Astronomical Society*, 517: 632, 2022.
- Liu, Yao; Linz, Hendrik; Fang, Min; Henning, Thomas; Wolf, Sebastian; Flock, Mario; Rosotti, Giovanni P.; Wang, Hongchi; Li, Dafa "Underestimation of the dust mass in protoplanetary disks: Effects of disk structure and dust properties," *Astronomy and Astrophysics*, 668: A175, 2022.
- Liu, Yao; Zhu, Ming "Evolution of Galaxy Types and H I Gas in Hickson Compact Groups," *Research in Astronomy and Astrophysics*, 22: 105018, 2022.
- Liu, Yuanqi; Wang, Ran; Momjian, Emmanuel; Wagg, Jeff; Yang, Xiaolong; An, Tao; Shao, Yali; Carilli, Chris L.; Wu, Xue-Bing; Fan, Xiaohui;

## APPENDIX A: PUBLICATIONS

- Walter, Fabian; Jiang, Linhua; Li, Qiong; Li, Jianan; Fei, Qinyue; Xu, Fuxiang "Exploring the Radio Spectral Energy Distribution of the Ultraluminous Radio-quiet Quasar SDSS J0100+2802 at Redshift 6.3," *The Astrophysical Journal*, 929: 69, 2022.
- Liu, Yuanqi; Wang, Ran; Momjian, Emmanuel; Zhang, Yingkang; An, Tao; Yang, Xiaolong; Wagg, Jeff; Bañados, Eduardo; Omont, Alain "VLBA Reveals the Absence of a Compact Radio Core in the Radio-intermediate Quasar J2242+0334 at  $z = 5.9$ ," *The Astrophysical Journal*, 939: L5, 2022.
- Loi, F.; Serra, P.; Murgia, M.; Govoni, F.; Anderson, C.; Heald, G.; Kleiner, D.; Lenc, E.; Vacca, V.; Maccagni, F. M.; Dettmar, R. J. "A depolarizing H I tidal tail in the western lobe of Fornax A," *Astronomy and Astrophysics*, 660: A48, 2022.
- Long, Feng; Andrews, Sean M.; Rosotti, Giovanni; Harsono, Daniel; Pinilla, Paola; Wilner, David J.; Öberg, Karin I.; Teague, Richard; Trapman, Leon; Tabone, Benoît "Gas Disk Sizes from CO Line Observations: A Test of Angular Momentum Evolution," *The Astrophysical Journal*, 931: 6, 2022.
- Long, Feng; Andrews, Sean M.; Zhang, Shangjia; Qi, Chunhua; Benisty, Myriam; Facchini, Stefano; Isella, Andrea; Wilner, David J.; Bae, Jaehan; Huang, Jane; Loomis, Ryan A.; Öberg, Karin I.; Zhu, Zhaohuan "ALMA Detection of Dust Trapping around Lagrangian Points in the LkCa 15 Disk," *The Astrophysical Journal*, 937: L1, 2022.
- López-Gutiérrez, M. M.; Bravo-Alfaro, H.; Van Gorkom, J. H.; Caretta, C. A.; Durret, F.; Núñez-Beltrán, L. M.; Jaffé, Y. L.; Hirschmann, M.; Pérez-Millán, D. "Environmental cluster effects and galaxy evolution: The H I properties of the Abell clusters A85/A496/A2670," *Monthly Notices of the Royal Astronomical Society*, 517: 1218, 2022.
- Lovell, C. C.; Geach, J. E.; Davé, R.; Narayanan, D.; Coppin, K. E. K.; Li, Q.; Franco, M.; Privon, G. C. "An orientation bias in observations of submillimetre galaxies," *Monthly Notices of the Royal Astronomical Society*, 515: 3644, 2022.
- Lowe, Ian; Mason, Brian; Bhandarkar, Tanay; Clark, S. E.; Devlin, Mark; Dicker, Simon R.; Duff, Shannon M.; Friesen, Rachel; Hacar, Alvaro; Hensley, Brandon; Mroczkowski, Tony; Naess, Sigurd; Romero, Charles; Sadavoy, Sarah; Salatino, Maria; Sarazin, Craig; Orłowski-Scherer, John; Schillaci, Alessandro; Sievers, Jonathan; Stanke, Thomas; Stutz, Amelia; Xu, Zhilei "A Study of 90 GHz Dust Emissivity on Molecular Cloud and Filament Scales," *The Astrophysical Journal*, 929: 102, 2022.
- Lu, Anan; Boyce, Hope; Haggard, Daryl; Bureau, Martin; Liang, Fu-Heng; Liu, Lijie; Choi, Woora; Cappellari, Michele; Chemin, Laurent; Chevance, Mélanie; Davis, Timothy A.; Drissen, Laurent; Elford, Jacob S.; Gensior, Jindra; Kruijssen, J. M. Diederik; Martin, Thomas; Massé, Etienne; Robert, Carmelle; Ruffa, Ilaria; Rousseau-Nepton, Laurie; Sarzi, Marc; Savard, Gabriel; Williams, Thomas G. "WISDOM project - XI. Star formation efficiency in the bulge of the AGN-host Galaxy NGC 3169 with SITELLE and ALMA," *Monthly Notices of the Royal Astronomical Society*, 514: 5035, 2022.
- Lu, Ting-Yi; Goto, Tomotsugu; Hashimoto, Tetsuya; Santos, Daryl Joe D.; Wong, Yi Hang Valerie; Kim, Seong Jin; Hsiao, Tiger Y.-Y.; Kilerci, Ece; Ho, Simon C.-C.; Nagao, Tohru; Matsuoka, Yoshiki; Onoue, Masafusa; Toba, Yoshiki; Shellqs Collaboration "Subaru High-z Exploration of Low-Luminosity Quasars (SHELLQs) - XV. Constraining the cosmic reionization at  $5.5 < z < 7$ ," *Monthly Notices of the Royal Astronomical Society*, 517: 1264, 2022.
- Lu, Xing; Li, Guang-Xing; Zhang, Qizhou; Lin, Yuxin "A massive Keplerian protostellar disk with flyby-induced spirals in the Central Molecular Zone," *Nature Astronomy*, 6: 837, 2022.
- Luber, N.; Müller, A.; Van Gorkom, J. H.; Poggianti, B. M.; Vulcani, B.; Franchetto, A.; Bacchini, C.; Bettoni, D.; Deb, T.; Fritz, J.; Gullieuszik, M.; Ignesti, A.; Jaffe, Y.; Moretti, A.; Paladino, R.; Ramatsoku, M.; Serra, P.; Smith, R.; Tomicic, N.; Tonnesen, S.; Verheijen, M.; Wolter, A. "GASP XXXVII: The Most Extreme Jellyfish Galaxies Compared with Other Disk Galaxies in Clusters, an H I Study," *The Astrophysical Journal*, 927: 39, 2022.
- Luber, N.; Pearson, Sarah; Putman, Mary E.; Besla, Gurtina; Stierwalt, Sabrina; Meyers, Joel P. "Investigating the Baryon Cycle in Interacting Dwarfs with the Very Large Array and Pan-STARRS," *The Astrophysical Journal*, 163: 49, 2022.
- Luo, Qiu-Yi; Liu, Tie; Tatematsu, Ken'ichi; Liu, Sheng-Yuan; Li, Pak Shing; Di Francesco, James; Johnstone, Doug; Goldsmith, Paul F.; Dutta, Somnath; Hirano, Naomi; Lee, Chin-Fei; Li, Di; Kim, Kee-Tae; Won Lee, Chang; Lee, Jeong-Eun; Liu, Xun-Chuan; Juvela, Mika; He, Jinhua; Qin, Sheng-Li; Liu, Hong-Li; Eden, David; Kwon, Woojin; Sahu, Dipen; Li, Shanghuo; Xu, Feng-Wei; Zhang, Si-Ju; Hsu, Shih-Ying; Bronfman, Leonardo; Sanhueza, Patricio; Pelkonen, Veli-Matti; Zhou, Jian-Wen; Liu, Rong; Gu, Qi-Lao; Wu, Yue-Fang; Mai, Xiao-Feng; Falgarone, Edith; Shen, Zhi-Qiang "ALMA Survey of Orion Planck Galactic Cold Clumps (ALMASOP): How Do Dense Core Properties Affect the Multiplicity of Protostars?," *The Astrophysical Journal*, 931: 158, 2022.
- Luo, Yingjie; Chen, Bin; Yu, Sijie; Battaglia, Marina; Sharma, Rohit "Multiple Regions of Nonthermal Quasiperiodic Pulsations during the Impulsive Phase of a Solar Flare," *The Astrophysical Journal*, 940: 137, 2022.
- Lyu, Fen; Cheng, Ji-Gui; Liang, En-Wei; Deng, Can-Min; An, Tao; Lin, Qing "Confining Burst Energy Function and Spectral Fringe Pattern of FRB 20121102A with Multifrequency Observations," *The Astrophysical Journal*, 941: 127, 2022.
- Macgregor, Meredith A.; Hurt, Spencer A.; Stark, Christopher C.; Howard, Ward S.; Weinberger, Alycia J.; Ren, Bin; Schneider, Glenn; Choquet, Elodie; Mawet, Dmitri "ALMA Images the Eccentric HD 53143 Debris Disk," *The Astrophysical Journal*, 933: L1, 2022.
- Macleod, G. C.; Yonekura, Y.; Tanabe, Y.; Baan, W. A.; Brogan, C. L.; Burns, R. A.; Chibueze, J. O.; Houde, M.; Hunter, T. R.; Kurtz, S. E.; Rajabi, F.; Smits, D. P.; Stecklum, B.; Sugiyama, K. "Two periods instead of one in a single 6.7 GHz methanol maser feature in G9.62+0.20E," *Monthly Notices of the Royal Astronomical Society*, 516: L96, 2022.
- Maeda, Fumiya; Egusa, Fumi; Ohta, Kouji; Fujimoto, Yusuke; Habe, Asao; Asada, Yoshihisa "CO(2-1)/CO(1-0) Line Ratio on a 100 Parsec Scale in the Nearby Barred Galaxy NGC 1300," *The Astrophysical Journal*, 926: 96, 2022.
- Mahony, Elizabeth K.; Allison, James R.; Sadler, Elaine M.; Ellison, Sara L.; Mao, Sui Ann; Morganti, Raffaella; Moss, Vanessa A.; Seta, Amit; Tadhunter, Clive N.; Weng, Simon; Whiting, Matthew T.; Yoon, Hyein; Bell, Martin; Bunton, John D.; Harvey-Smith, Lisa; Kimball, Amy; Koribalski, Bärbel S.; Voronkov, Max A. "H I absorption at  $z = 0.7$  against the lobe of the powerful radio galaxy PKS 0409-75," *Monthly Notices of the Royal Astronomical Society*, 509: 1690, 2022.
- Maina, E. K.; Mohapatra, Abhisek; Józsa, G. I. G.; Gupta, N.; Combes, F.; Deka, P.; Wagnveld, J. D.; Sriannand, R.; Balashev, S. A.; Chen, Hsiao-Wen; Krogager, J.-K.; Momjian, E.; Noterdaeme, P.; Petitjean, P. "Mapping H I 21-cm in the Klemola 31 group at  $z = 0.029$ : emission and absorption towards PKS 2020-370," *Monthly Notices of the Royal Astronomical Society*, 516: 2050, 2022.
- Maiorano, Michele; De Paolis, Francesco; Nucita, Achille A. "Description and Application of the Surfing Effect," *Universe*, 8: 620, 2022.
- Maity, A. K.; Dewangan, L. K.; Sano, H.; Tachihara, K.; Fukui, Y.; Bhadari, N. K. "Unraveling the Observational Signatures of Cloud-Cloud Collision and Hub-filament Systems in W31," *The Astrophysical Journal*, 934: 2, 2022.
- Malefahlo, Eliab D.; Jarvis, Matt J.; Santos, Mario G.; White, Sarah V.; Adams, Nathan J.; Bowler, Rebecca A. A. "A deep radio view of the evolution of the cosmic star formation rate density from a stellar-mass-selected sample in VLA-COSMOS," *Monthly Notices of the Royal Astronomical Society*, 509: 4291, 2022.
- Mancera Piña, Pavel E.; Fraternali, Filippo; Oosterloo, Tom; Adams, Elizabeth A. K.; Oman, Kyle A.; Leisman, Lukas "No need for dark matter: resolved kinematics of the ultra-diffuse galaxy AGC 114905," *Monthly Notices of the Royal Astronomical Society*, 521: 3230, 2022.
- Manna, Arijit; Pal, Sabyasachi "First detection of methyl formate in the hot molecular core IRAS 18566+0408," *Astrophysics and Space Science*, 367: 94, 2022.

- Manna, Arijit; Pal, Sabyasachi "Detection of interstellar cyanamide (NH<sub>2</sub>CN) towards the hot molecular core G10.47+0.03," *Journal of Astrophysics and Astronomy*, 43: 83, 2022.
- Manna, Arijit; Pal, Sabyasachi "Identification of interstellar amino acetonitrile in the hot molecular core G10.47+0.03: Possible glycine survey candidate for the future," *Life Sciences and Space Research*, 34: 9, 2022.
- Manning, Sinclair M.; Casey, Caitlin M.; Zavala, Jorge A.; Magdis, Georgios E.; Drew, Patrick M.; Champagne, Jaclyn B.; Aravena, Manuel; Béthermin, Matthieu; Clements, David L.; Finkelstein, Steven L.; Fujimoto, Seiji; Hayward, Christopher C.; Hodge, Jacqueline A.; Ilbert, Olivier; Kartaltepe, Jeyhan S.; Knudsen, Kirsten K.; Koekemoer, Anton M.; Man, Allison W. S.; Sanders, David B.; Sheth, Kartik; Spilker, Justin S.; Staguhn, Johannes; Talia, Margherita; Treister, Ezequiel; Yun, Min S. "Characterization of Two 2 mm detected Optically Obscured Dusty Star-forming Galaxies," *The Astrophysical Journal*, 925: 23, 2022.
- Manoharan, P. K.; Perillat, Phil; Salter, C. J.; Ghosh, Tapasi; Raizada, Shikha; Lynch, Ryan S.; Bonsall-Pisano, Amber; Joshi, B. C.; Roshi, Anish; Brum, Christiano; Venkataraman, Arun "Probing the Plasma Tail of Interstellar Comet 2/Borisov," *The Planetary Science Journal*, 3: 266, 2022.
- Maresca, Jacob; Dye, Simon; Amvrosiadis, Aristeidis; Bendo, George; Cooray, Asantha; De Zotti, Gianfranco; Dunne, Loretta; Eales, Stephen; Furlanetto, Cristina; González-Nuevo, Joaquín; Greener, Michael; Ivison, Robert; Lapi, Andrea; Negrello, Mattia; Riechers, Dominik; Serjeant, Stephen; Tergolina, Mônica; Wardlow, Julie "Modelling high-resolution ALMA observations of strongly lensed dusty star-forming galaxies detected by Herschel," *Monthly Notices of the Royal Astronomical Society*, 512: 2426, 2022.
- Margulès, L.; Remijan, A.; Belloche, A.; Motiyenko, R. A.; Mcguire, B. A.; Xue, C.; Müller, H. S. P.; Garrod, R. T.; Menten, K. M.; Guillemin, J.-C. "Submillimeter wave spectroscopy and astronomical search for 1-propanimine," *Astronomy and Astrophysics*, 663: A132, 2022.
- Marinelli, A. D.; Isequilla, N.; Ortega, M. E.; Paron, S. "Study of the fragmentation of high mass molecular clumps," *Boletín de la Asociación Argentina de Astronomía La Plata Argentina*, 63: 146, 2022.
- Markov, V.; Carniani, S.; Vallini, L.; Ferrara, A.; Pallottini, A.; Maiolino, R.; Gallerani, S.; Pentericci, L. "The interstellar medium of high-redshift galaxies: Gathering clues from C III] and [C II] lines," *Astronomy and Astrophysics*, 663: A172, 2022.
- Marongiu, M.; Guidorzi, C.; Stratta, G.; Gomboc, A.; Jordana-Mitjans, N.; Dichiaro, S.; Kobayashi, S.; Kopač, D.; Mundell, C. G. "Radio data challenge the broadband modelling of GRB 160131A afterglow," *Astronomy and Astrophysics*, 658: A11, 2022.
- Marr, Metea; Dong, Ruobing "The Appearance of Vortices in Protoplanetary Disks in Near-infrared Scattered Light," *The Astrophysical Journal*, 930: 80, 2022.
- Martin, G.; Bazkiaei, A. E.; Iodice, M. Spavone E.; Mihos, J. C.; Montes, M.; Benavides, J. A.; Brough, S.; Carlin, J. L.; Collins, C. A.; Duc, P. A.; Gómez, F. A.; Galaz, G.; Hernández-Toledo, H. M.; Jackson, R. A.; Kaviraj, S.; Knapen, J. H.; Martínez-Lombilla, C.; Mcgee, S.; O'Ryan, D.; Prole, D. J.; Rich, R. M.; Román, J.; Shah, E. A.; Starkenburg, T. K.; Watkins, A. E.; Zaritsky, D.; Pichon, C.; Armus, L.; Bianconi, M.; Buitrago, F.; Busá, I.; Davis, F.; Demarco, R.; Desmons, A.; García, P.; Graham, A. W.; Holwerda, B.; Hon, D. S.-H.; Khalid, A.; Klehammer, J.; Klutse, D. Y.; Lazar, I.; Nair, P.; Noakes-Kettel, E. A.; Rutkowski, M.; Saha, K.; Sahu, N.; Sola, E.; Vázquez-Mata, J. A.; Vera-Casanova, A.; Yoon, I. "Preparing for low surface brightness science with the Vera C. Rubin Observatory: characterisation of tidal features from mock images," *Monthly Notices of the Royal Astronomical Society*, 513: 1459, 2022.
- Martínez, N. C.; Areal, M. B.; Paron, S. "Studying a hot molecular core embedded in a photodissociation region," *Boletín de la Asociación Argentina de Astronomía La Plata Argentina*, 63: 140, 2022.
- Martínez-Brunner, Rafael; Casassus, Simon; Pérez, Sebastián; Hales, Antonio; Weber, Philipp; Carcamo, Miguel; Arce-Tord, Carla; Cieza, Lucas; Garufi, Antonio; Marino, Sebastián; Zurló, Alice "High-resolution ALMA observations of V4046 Sgr: a circumbinary disc with a thin ring," *Monthly Notices of the Royal Astronomical Society*, 510: 1248, 2022.
- Martsen, Ashley R.; Ransom, Scott M.; Decesar, Megan E.; Freire, Paulo C. C.; Hessels, Jason W. T.; Ho, Anna Y. Q.; Lynch, Ryan S.; Stairs, Ingrid H.; Wang, Yuankun "Radio Pulse Profiles and Polarization of the Terzan 5 Pulsars," *The Astrophysical Journal*, 941: 22, 2022.
- Maschmann, Daniel; Melchior, Anne-Laure; Combes, Françoise; Mazzilli Ciraulo, Barbara; Freundlich, Jonathan; Halle, Anaëlle; Drabent, Alexander "Central star formation in double-peak, gas-rich radio galaxies," *Astronomy and Astrophysics*, 664: A125, 2022.
- Massardi, M.; Bonato, M.; López-Cañiego, M.; Galluzzi, V.; De Zotti, G.; Bonavera, L.; González-Nuevo, J.; Lapi, A.; Liuzzo, E. "Selecting a complete sample of blazars in sub-millimetre catalogues," *Monthly Notices of the Royal Astronomical Society*, 513: 6013, 2022.
- Matthews, L. D.; Dupree, A. K. "Spatially Resolved Observations of Betelgeuse at  $\lambda 7$  mm and  $\lambda 1.3$  cm Just prior to the Great Dimming," *The Astrophysical Journal*, 934: 131, 2022.
- Maud, Luke T.; Asaki, Yoshiharu; Dent, William R. F.; Hirota, Akihiko; Fomalont, Edward B.; Takahashi, Satoko; Matsushita, Satoki; Phillips, Neil M.; Sawada, Tsuyoshi; Corder, Stuart; Carpenter, John "ALMA High-frequency Long-baseline Campaign in 2017: An Investigation of Phase-referencing Cycle Times and Effective Baseline Lengths Using Band-to-band and In-band Phase Calibration Techniques," *The Astrophysical Journal Supplement Series*, 259: 10, 2022.
- Maureira, María José; Gong, Munan; Pineda, Jaime E.; Liu, Huiyu Baobab; Silsbee, Kedron; Caselli, Paola; Zamponi, Joaquín; Segura-Cox, Dominique M.; Schmiedeke, Anika "Dust Hot Spots at 10 au Scales around the Class O Binary IRAS 16293-2422 A: A Departure from the Passive Irradiation Model," *The Astrophysical Journal*, 941: L23, 2022.
- Mazoochi, F.; Miraghaei, H.; Riaz, N. "The relation between the radio emission of the core and host galaxy properties in Fanaroff-Riley type II radio galaxies," *Publications of the Astronomical Society of Australia*, 39: e021, 2022.
- Mccaffrey, Trevor V.; Kimball, Amy E.; Momjian, Emmanuel; Richards, Gordon T. "Kiloparsec-scale Radio Structure in z 0.25 Radio-quiet QSOs," *The Astronomical Journal*, 164: 122, 2022.
- Mcguire, Brett A. "2021 Census of Interstellar, Circumstellar, Extragalactic, Protoplanetary Disk, and Exoplanetary Molecules," *The Astrophysical Journal Supplement Series*, 259: 30, 2022.
- Mckinnon, M. M. "Exponential Fluctuations in the Modes of Orthogonal Polarization in Pulsar Radio Emission," *The Astrophysical Journal*, 937: 92, 2022.
- Mei, Alessio; Banerjee, Biswajit; Oganessian, Gor; Salafia, Om Sharan; Giarratana, Stefano; Branchesi, Marica; D'Avanzo, Paolo; Campana, Sergio; Ghirlanda, Giancarlo; Ronchini, Samuele; Shukla, Amit; Tiwari, Pawan "Gigaelectronvolt emission from a compact binary merger," *Nature*, 612: 236, 2022.
- Mejía-Restrepo, Julian E.; Trakhtenbrot, Benny; Koss, Michael J.; Oh, Kyuseok; Den Brok, Jakob; Stern, Daniel; Powell, Meredith C.; Ricci, Federica; Caglar, Turgay; Ricci, Claudio; Bauer, Franz E.; Treister, Ezequiel; Harrison, Fiona A.; Urry, C. M.; Ananna, Tonima Tasnim; Asmus, Daniel; Assef, Roberto J.; Bär, Rudolf E.; Bessiere, Patricia S.; Bertscher, Leonard; Ichikawa, Kohei; Kakkad, Darshan; Kamraj, Nikita; Muroshitzky, Richard; Privon, George C.; Rojas, Alejandra F.; Sani, Eleonora; Schwawinski, Kevin; Veilleux, Sylvain "BASS. XXV. DR2 Broad-line-based Black Hole Mass Estimates and Biases from Obscuration," *The Astrophysical Journal Supplement Series*, 261: 5, 2022.
- Mendigutía, I.; Solano, E.; Vioque, M.; Balaguer-Núñez, L.; Ribas, A.; Huéllamo, N.; Rodrigo, C. "Gaia EDR3 comparative study of protoplanetary disk fractions in young stellar clusters," *Astronomy and Astrophysics*, 664: A66, 2022.
- Menezes, Fabian; Selhorst, Caius L.; De Castro, Carlos Guillermo Giménez; Valio, Adriana "Subterahertz Radius and Limb Brightening of the Sun Derived from SST and ALMA," *Monthly Notices of the Royal Astronomical Society*, 511: 877, 2022.

## APPENDIX A: PUBLICATIONS

- Meng, F.; Sánchez-Monge, Á.; Schilke, P.; Ginsburg, A.; Depree, C.; Budaiev, N.; Jeff, D.; Schmiedeke, A.; Schwörer, A.; Veena, V. S.; Möller, Th. "The physical and chemical structure of Sagittarius B2. VI. UCHii regions in Sgr B2," *Astronomy and Astrophysics*, 666: A31, 2022.
- Meyer, Romain A.; Decarli, Roberto; Walter, Fabian; Li, Qiong; Wang, Ran; Mazzucchelli, Chiara; Bañados, Eduardo; Farina, Emanuele P.; Venemans, Bram "Constraining Galaxy Overdensities around Three z 6.5 Quasars with ALMA and MUSE," *The Astrophysical Journal*, 927: 141, 2022.
- Michel, Arnaud; Sadavoy, Sarah I.; Sheehan, Patrick D.; Looney, Leslie W.; Cox, Erin G. "A Millimeter-multiwavelength Continuum Study of VLA 1623 West," *The Astrophysical Journal*, 937: 104, 2022.
- Michiyama, Tomonari; Inoue, Yoshiyuki; Doi, Akihiro; Khangulyan, Dmitry "ALMA Detection of Parsec-scale Blobs at the Head of a Kiloparsec-scale Jet in the Nearby Seyfert Galaxy NGC 1068," *The Astrophysical Journal*, 936: L1, 2022.
- Migliori, G.; Siemiginowska, A.; Cheung, C. C.; Celotti, A.; Giroletti, M.; Giovannini, G.; Paggi, A.; Liuzzo, E. "Discovery of a bright extended X-ray jet in RGB J1512+020A," *Monthly Notices of the Royal Astronomical Society*, 512: 4639, 2022.
- Miraghaei, Halime "A Statistical Analysis on the Morphology and Color of Galaxies Hosting Radio-loud Active Galactic Nuclei," *The Astronomical Journal*, 164: 246, 2022.
- Missaglia, Valentina; Murgia, Matteo; Massaro, Francesco; Paggi, Alessandro; Jimenez-Gallardo, Ana; Forman, William R.; Kraft, Ralph P.; Balmaverde, Barbara "High-frequency Radio Imaging of 3CR 403.1 with the Sardinia Radio Telescope," *The Astrophysical Journal*, 936: 10, 2022.
- Miyawaki, Ryosuke; Hayashi, Masahiko; Hasegawa, Tetsuo "W 49 N MCN-a: A disk-accreting massive protostar embedded in an early-phase hot molecular core," *Publications of the Astronomical Society of Japan*, 74: 705, 2022.
- Mohan, A.; Wedemeyer, S.; Hauschildt, P. H.; Pandit, S.; Saberi, M. "EMISSA (Exploring millimetre indicators of solar-stellar activity). II. Towards a robust indicator of stellar activity," *Astronomy and Astrophysics*, 664: L9, 2022.
- Molina, Francisco; Vos, Joris; Németh, Péter; Østensen, Roy; Vuković, Maja; Tkachenko, Andrew; Van Winckel, Hans "Orbital and atmospheric parameters of two wide O-type subdwarf binaries: BD-11o162 and Feige 80," *Astronomy and Astrophysics*, 658: A122, 2022.
- Mooley, K. P.; Margalit, B.; Law, C. J.; Perley, D. A.; Deller, A. T.; Lazio, T. J. W.; Bietenholz, M. F.; Shimwell, T.; Intema, H. T.; Gaensler, B. M.; Metzger, B. D.; Dong, D. Z.; Hallinan, G.; Ofek, E. O.; Sironi, L. "Late-time Evolution and Modeling of the Off-axis Gamma-Ray Burst Candidate FIRST J141918.9+394036," *The Astrophysical Journal*, 924: 16, 2022.
- Mooley, Kunal P.; Anderson, Jay; Lu, Wenbin "Optical superluminal motion measurement in the neutron-star merger GW170817," *Nature*, 610: 273, 2022.
- Moravec, Emily; Svoboda, Jiří; Borkar, Abhijeet; Boorman, Peter; Kynoch, Daniel; Panessa, Francesca; Mingo, Beatriz; Guainazzi, Matteo "Do radio active galactic nuclei reflect X-ray binary spectral states?," *Astronomy and Astrophysics*, 662: A28, 2022.
- Morishita, T.; Abdurro'Uf; Hirashita, H.; Newman, A. B.; Stiavelli, M.; Chiaberge, M. "Compact Dust Emission in a Gravitationally Lensed Massive Quiescent Galaxy at z = 2.15 Revealed in 130 pc Resolution Observations by the Atacama Large Millimeter/submillimeter Array," *The Astrophysical Journal*, 938: 144, 2022.
- Morokuma-Matsui, Kana; Bekki, Kenji; Wang, Jing; Serra, Paolo; Koyama, Yusei; Morokuma, Tomoki; Egusa, Fumi; For, Bi-Qing; Nakanishi, Kouichiro; Koribalski, Bärbel S.; Okamoto, Takashi; Kodama, Tadayuki; Lee, Bumhyun; Maccagni, Filippo M.; Miura, Rie E.; Espada, Daniel; Takeuchi, Tsutomu T.; Yang, Dong; Lee, Minju M.; Ueda, Masaki; Matsushita, Kyoko "CO(J = 1-0) Mapping Survey of 64 Galaxies in the Fornax Cluster with the ALMA Morita Array," *The Astrophysical Journal Supplement Series*, 263: 40, 2022.
- Morris, Melissa Elizabeth; Wilcots, Eric; Hooper, Eric; Heinz, Sebastian "How Does Environment Affect the Morphology of Radio AGN?," *The Astronomical Journal*, 163: 280, 2022.
- Motte, F.; Bontemps, S.; Csengeri, T.; Pouteau, Y.; Louvet, F.; Stutz, A. M.; Cunningham, N.; López-Sepulcre, A.; Brouillet, N.; Galván-Madrid, R.; Ginsburg, A.; Maud, L.; Men'Shchikov, A.; Nakamura, F.; Nony, T.; Sanhueza, P.; Álvarez-Gutiérrez, R. H.; Armante, M.; Baug, T.; Bonfand, M.; Busquet, G.; Chapillon, E.; Díaz-González, D.; Fernández-López, M.; Guzmán, A. E.; Herpin, F.; Liu, H.-L.; Olguin, F.; Towner, A. P. M.; Bally, J.; Battersby, C.; Braine, J.; Bronfman, L.; Chen, H. -R. V.; Dell'Ova, P.; Di Francesco, J.; González, M.; Gusdorf, A.; Hennebelle, P.; Izumi, N.; Joncour, I.; Lee, Y.-N.; Lefloch, B.; Lesaffre, P.; Lu, X.; Menten, K. M.; Mignon-Risse, R.; Molet, J.; Moraux, E.; Mundy, L.; Nguyen Luong, Q.; Reyes, N.; Reyes Reyes, S. D.; Robitaille, J.-F.; Rosolowsky, E.; Sandoval-Garrido, N. A.; Schuller, F.; Svoboda, B.; Tatematsu, K.; Thomasson, B.; Walker, D.; Wu, B.; Whitworth, A. P.; Wyrowski, F. "ALMA-IMF. I. Investigating the origin of stellar masses: Introduction to the Large Program and first results," *Astronomy and Astrophysics*, 662: A8, 2022.
- Moutzouri, M.; Mackey, J.; Carrasco-González, C.; Gong, Y.; Brose, R.; Zargaryan, D.; Toalá, J. A.; Menten, K. M.; Gvaramadze, V. V.; Rugel, M. R. "And then they were two: Detection of non-thermal radio emission from the bow shocks of two runaway stars," *Astronomy and Astrophysics*, 663: A80, 2022.
- Mroczkowski, Tony; Donahue, Megan; Van Marrewijk, Joshiwa; Clarke, Tracy E.; Hoffer, Aaron; Intema, Huib; Di Mascolo, Luca; Popping, Gergö; Pratt, Gabriel W.; Sun, Ming; Voit, Mark "The strongest cool core in REXCESS: Missing X-ray cavities in RXC J2014.8-2430," *Astronomy and Astrophysics*, 665: A48, 2022.
- Murchikova, Lena; White, Christopher J.; Ressler, Sean M. "Remarkable Correspondence of the Sagittarius A\* Submillimeter Variability with a Stellar-wind-fed Accretion Flow Model," *The Astrophysical Journal*, 932: L21, 2022.
- Murillo, N. M.; Van Dishoeck, E. F.; Hacar, A.; Harsono, D.; Jørgensen, J. K. "A cold accretion flow onto one component of a multiple protostellar system," *Astronomy and Astrophysics*, 658: A53, 2022.
- Murphy, Eric J. "The Relative Importance of Thermal Gas, Radiation, and Magnetic Pressures around Star-forming Regions in Normal Galaxies and Dusty Starbursts," *The Astrophysical Journal*, 938: 135, 2022.
- Murphy, Eric Joseph "The Role of Radio Observations in Studies of Infrared-Bright Galaxies: Prospects for a Next-Generation Very Large Array," *Universe*, 8: 329, 2022.
- Mus, A.; Martí-Vidal, I.; Wielgus, M.; Stroud, G. "A first search of transients in the Galactic center from 230 GHz ALMA observations," *Astronomy and Astrophysics*, 666: A39, 2022.
- Nagy, David; Dessauges-Zavadsky, Miroslava; Richard, Johan; Schaerer, Daniel; Combes, Françoise; Messa, Matteo; Chisholm, John "Radial profiles of lensed z 1 galaxies on sub-kiloparsec scales," *Astronomy and Astrophysics*, 657: A25, 2022.
- Nair, A.; Vivek, M. "Fraction of broad absorption line quasars in different radio morphologies," *Monthly Notices of the Royal Astronomical Society*, 511: 4946, 2022.
- Nanci, C.; Giroletti, M.; Orienti, M.; Migliori, G.; Moldón, J.; Garrappa, S.; Kadler, M.; Ros, E.; Buson, S.; An, T.; Pérez-Torres, M. A.; D'Ammando, F.; Mohan, P.; Agudo, I.; Sohn, B. W.; Castro-Tirado, A. J.; Zhang, Y. "Observing the inner parsec-scale region of candidate neutrino-emitting blazars," *Astronomy and Astrophysics*, 663: A129, 2022.
- Narang, Mayank "The nature of the radio source detected towards the exoplanet system 1RXS1609.1-210524," *Monthly Notices of the Royal Astronomical Society*, 515: 2015, 2022.
- Narang, Nancy; Chandrashekar, Kalugodu; Jafarzadeh, Shahin; Fleck, Bernhard; Szydlarski, Mikołaj; Wedemeyer, Sven "Power distribution of oscillations in the atmosphere of a plage region. Joint observations with ALMA, IRIS, and SDO," *Astronomy and Astrophysics*, 661: A95, 2022.
- Nascimento, R. S.; Rodríguez-Ardila, A.; Dahmer-Hahn, L.; Fonseca-Faria,



- M. A.; Riffel, R.; Marinello, M.; Beuchert, T.; Callingham, J. R. "Optical properties of Peaked Spectrum radio sources," *Monthly Notices of the Royal Astronomical Society*, 511: 214, 2022.
- Nayana, A. J.; Chandra, Poonam; Krishna, Anoop; Anupama, G. C. "Radio Evolution of a Type IIb Supernova SN 2016gkg," *The Astrophysical Journal*, 934: 186, 2022.
- Nazari, P.; Meijerhof, J. D.; Van Gelder, M. L.; Ahmadi, A.; Van Dishoeck, E. F.; Tabone, B.; Langeroodi, D.; Ligterink, N. F. W.; Jaspers, J.; Beltrán, M. T.; Fuller, G. A.; Sánchez-Monge, Á.; Schilke, P. "N-bearing complex organics toward high-mass protostars. Constant ratios pointing to formation in similar pre-stellar conditions across a large mass range," *Astronomy and Astrophysics*, 668: A109, 2022.
- Ngeow, Chow-Choong; Bhardwaj, Anupam; Dekany, Richard; Duev, Dmitry A.; Graham, Matthew J.; Groom, Steven L.; Mahabal, Ashish A.; Masci, Frank J.; Medford, Michael S.; Riddle, Reed "Zwicky Transient Facility and Globular Clusters: The RR Lyrae gri-band Period-Luminosity-Metallicity and Period-Wesenheit-Metallicity Relations," *The Astronomical Journal*, 163: 239, 2022.
- Ngeow, Chow-Choong; Bhardwaj, Anupam; Henderson, Jing-Yi; Graham, Matthew J.; Laher, Russ R.; Medford, Michael S.; Purdum, Josiah; Rusholme, Ben "Zwicky Transient Facility and Globular Clusters: The Period-Luminosity and Period-Wesenheit Relations for Type II Cepheids," *The Astronomical Journal*, 164: 154, 2022.
- Nguyen, Dieu D.; Bureau, Martin; Thater, Sabine; Nyland, Kristina; Den Brok, Mark; Cappellari, Michele; Davis, Timothy A.; Greene, Jenny E.; Neumayer, Nadine; Imanishi, Masatoshi; Izumi, Takuma; Kawamuro, Taiki; Baba, Shunsuke; Nguyen, Phuong M.; Iguchi, Satoru; Tsukui, Takafumi; Lam, T. N.; Ho, Than "The MBHBM Project - II. Molecular gas kinematics in the lenticular galaxy NGC 3593 reveal a supermassive black hole," *Monthly Notices of the Royal Astronomical Society*, 509: 2920, 2022.
- Nguyen, H.; Rugel, M. R.; Murugesan, C.; Menten, K. M.; Brunthaler, A.; Urquhart, J. S.; Dokara, R.; Dzib, S. A.; Gong, Y.; Khan, S.; Medina, S.-N. X.; Ortiz-León, G. N.; Reich, W.; Wyrowski, F.; Yang, A. Y.; Beuther, H.; Cotton, W. D.; Pandian, J. D. "A global view on star formation: The GLOSTAR Galactic plane survey. V. 6.7 GHz methanol maser catalogue," *Astronomy and Astrophysics*, 666: A59, 2022.
- Nhung, Pham T.; Hoai, Do T.; Tuan-Anh, Pham; Darrulat, Pierre; Diep, Pham N.; Ngoc, Nguyen B.; Thai, Tran T. "Mira Ceti, Atypical Archetype," *The Astrophysical Journal*, 927: 169, 2022.
- Nieder, L.; Kerr, M.; Clark, C. J.; Bruel, P.; Cromartie, H. T.; Ransom, S. M.; Ray, P. S. "Is the Black-widow Pulsar PSR J1555-2908 in a Hierarchical Triple System?," *The Astrophysical Journal*, 931: L3, 2022.
- Niu, C.-H.; Aggarwal, K.; Li, D.; Zhang, X.; Chatterjee, S.; Tsai, C.-W.; Yu, W.; Law, C. J.; Burke-Spolaor, S.; Cordes, J. M.; Zhang, Y.-K.; Ocker, S. K.; Yao, J.-M.; Wan, P.; Feng, Y.; Niino, Y.; Bochenek, C.; Cruces, M.; Connor, L.; Jiang, J.-A.; Dai, S.; Luo, R.; Li, G.-D.; Miao, C.-C.; Niu, J.-R.; Anna-Thomas, R.; Sydnor, J.; Stern, D.; Wang, W.-Y.; Yuan, M.; Yue, Y.-L.; Zhou, D.-J.; Yan, Z.; Zhu, W.-W.; Zhang, B. "A repeating fast radio burst associated with a persistent radio source," *Nature*, 606: 873, 2022.
- Nokhrina, E. E.; Pashchenko, I. N.; Kutkin, A. M. "Parabolic jet shape on parsec scales in high redshift AGN," *Monthly Notices of the Royal Astronomical Society*, 509: 1899, 2022.
- Nolting, C.; Lacy, M.; Croft, S.; Fragile, P. C.; Linden, S. T.; Nyland, K.; Patil, P. "Observations and Simulations of Radio Emission and Magnetic Fields in Minkowski's Object," *The Astrophysical Journal*, 936: 130, 2022.
- Norfolk, Brodie J.; Pinte, Christophe; Calcino, Josh; Hammond, Iain; Van Der Marel, Nienke; Price, Daniel J.; Maddison, Sarah T.; Christiaens, Valentin; Gonzalez, Jean-François; Blakely, Dori; Rosotti, Giovanni; Ginski, Christian "The Origin of the Doppler Flip in HD 100546: A Large-scale Spiral Arm Generated by an Inner Binary Companion," *The Astrophysical Journal*, 936: L4, 2022.
- Oei, Martijn S. S. L.; Van Weeren, Reinout J.; Hardcastle, Martin J.; Botteon, Andrea; Shimwell, Tim W.; Dabhade, Pratik; Gast, Aivin R. D. J. G. I. B.; Röttgering, Huub J. A.; Brügggen, Marcus; Tasse, Cyril; Williams, Wendy L.; Shulevski, Aleksandar "The discovery of a radio galaxy of at least 5 Mpc," *Astronomy and Astrophysics*, 660: A2, 2022.
- Oh, Junghwan; Hodgson, Jeffrey A.; Trippe, Sascha; Krichbaum, Thomas P.; Kam, Minchul; Paraschos, Georgios Filippos; Kim, Jae-Young; Rani, Bindu; Sohn, Bong Won; Lee, Sang-Sung; Lico, Rocco; Liuzzo, Elisabetta; Bremer, Michael; Zensus, Anton "A persistent double nuclear structure in 3C 84," *Monthly Notices of the Royal Astronomical Society*, 509: 1024, 2022.
- Ohashi, Satoshi; Codella, Claudio; Sakai, Nami; Chandler, Claire J.; Ceccarelli, Cecilia; Alves, Felipe; Fedele, Davide; Hanawa, Tomoyuki; Durán, Aurora; Favre, Cécile; López-Sepulcre, Ana; Loinard, Laurent; Mercimek, Seyma; Murillo, Nadia M.; Podio, Linda; Zhang, Yichen; Aikawa, Yuri; Balucani, Nadia; Bianchi, Eleonora; Bouvier, Mathilde; Busquet, Gemma; Caselli, Paola; Caux, Emmanuel; Charnley, Steven; Choudhury, Spandan; Cuello, Nicolas; De Simone, Marta; Dulieu, Francois; Evans, Lucy; Feng, Siyi; Fontani, Francesco; Francis, Logan; Hama, Tetsuya; Herbst, Eric; Hirano, Shingo; Hirota, Tomoya; Imai, Muneaki; Isella, Andrea; Jiménez-Serra, Izaskun; Johnstone, Doug; Kahane, Claudine; Le Gal, Romane; Lefloch, Bertrand; Maud, Luke T.; Maureira, Maria Jose; Menard, Francois; Miotello, Anna; Moellenbrock, George; Mori, Shoji; Nakatani, Riouhei; Nomura, Hideko; Oba, Yasuhiro; O'Donoghue, Ross; Okoda, Yuki; Ospina-Zamudio, Juan; Oya, Yoko; Pineda, Jaime; Rimola, Albert; Sakai, Takeshi; Segura-Cox, Dominique; Shirley, Yancy; Svoboda, Brian; Taquet, Vianney; Testi, Leonardo; Vastel, Charlotte; Viti, Serena; Watanabe, Naoki; Watanabe, Yoshimasa; Witzel, Arezu; Xue, Ci; Zhao, Bo; Yamamoto, Satoshi "Misaligned Rotations of the Envelope, Outflow, and Disks in the Multiple Protostellar System of VLA 1623-2417: FAUST. III," *The Astrophysical Journal*, 927: 54, 2022.
- Ohashi, Satoshi; Kobayashi, Hiroshi; Sai, Jinshi; Sakai, Nami "No Evidence of the Significant Grain Growth but Tentative Discovery of Disk Substructure in a Disk around the Class I Protostar L1489 IRS," *The Astrophysical Journal*, 933: 23, 2022.
- Ohashi, Satoshi; Nakatani, Riouhei; Liu, Hanyu Baobab; Kobayashi, Hiroshi; Zhang, Yichen; Hanawa, Tomoyuki; Sakai, Nami "Formation of Dust Clumps with Sub-Jupiter Mass and Cold Shadowed Region in Gravitationally Unstable Disk around Class 0/I Protostar in L1527 IRS," *The Astrophysical Journal*, 934: 163, 2022.
- Okino, Hiroki; Akiyama, Kazunori; Asada, Keiichi; Gómez, José L.; Hada, Kazuhiro; Honma, Mareki; Krichbaum, Thomas P.; Kino, Motoki; Nagai, Hiroshi; Bach, Uwe; Blackburn, Lindy; Bouman, Katherine L.; Chael, Andrew; Crew, Geoffrey B.; Doeleman, Sheperd S.; Fish, Vincent L.; Goddi, Ciriaco; Issaoun, Sara; Johnson, Michael D.; Jorstad, Svetlana; Koyama, Shoko; Lonsdale, Colin J.; Lu, Ru-Sen; Martí-Vidal, Ivan; Matthews, Lynn D.; Mizuno, Yosuke; Moriyma, Kotaro; Nakamura, Masanori; Pu, Hung-Yi; Ros, Eduardo; Savolainen, Tuomas; Tazaki, Fumie; Wagner, Jan; Wielgus, Maciek; Zensus, Anton "Collimation of the Relativistic Jet in the Quasar 3C 273," *The Astrophysical Journal*, 940: 65, 2022.
- Oligun, Fernando A.; Sanhueza, Patricio; Ginsburg, Adam; Chen, Hwei-Ru Vivien; Zhang, Qizhou; Li, Shanghuo; Lu, Xing; Sakai, Takeshi "Digging into the Interior of Hot Cores with ALMA (DIHCA). II. Exploring the Inner Binary (Multiple) System Embedded in G335 MM1 ALMA1," *The Astrophysical Journal*, 929: 68, 2022.
- Olofsson, H.; Khouri, T.; Sargent, B. A.; Winnberg, A.; Blommaert, J. A. D. L.; Groenewegen, M. A. T.; Muller, S.; Kastner, J. H.; Meixner, M.; Otsuka, M.; Patel, N.; Ryde, N.; Srinivasan, S. "CO line observations of OH/IR stars in the inner Galactic Bulge: Characteristics of stars at the tip of the AGB," *Astronomy and Astrophysics*, 665: A82, 2022.
- Olofsson, J.; Thébault, P.; Kennedy, G. M.; Bayo, A. "The halo around HD 32297:  $\mu$ m-sized cometary dust," *Astronomy and Astrophysics*, 664: A122, 2022.
- O'Neill, S.; Kiehlmann, S.; Readhead, A. C. S.; Aller, M. F.; Blandford, R. D.; Liodakis, I.; Lister, M. L.; Mróz, P.; O'Dea, C. P.; Pearson, T. J.; Ravi, V.; Vallisneri, M.; Cleary, K. A.; Graham, M. J.; Grainge, K. J. B.; Hodges, M. W.; Hovatta, T.; Lähteenmäki, A.; Lamb, J. W.; Lazio, T. J. W.; Max-

## APPENDIX A: PUBLICATIONS

- Moerbeck, W.; Pavlidou, V.; Prince, T. A.; Reeves, R. A.; Tornikoski, M.; Vergara De La Parra, P.; Zensus, J. A. "The Unanticipated Phenomenology of the Blazar PKS 2131-021: A Unique Supermassive Black Hole Binary Candidate," *The Astrophysical Journal*, 926: L35, 2022.
- O'Neill, Theo J.; Inebetouw, Rémy; Bolatto, Alberto D.; Madden, Suzanne C.; Wong, Tony "Effects of CO-dark Gas on Measurements of Molecular Cloud Stability and the Size-Linewidth Relationship," *The Astrophysical Journal*, 933: 179, 2022.
- O'Neill, Theo J.; Inebetouw, Rémy; Sandstrom, Karin; Bolatto, Alberto D.; Jameson, Katherine E.; Carlson, Lynn R.; Finn, Molly K.; Meixner, Margaret; Sabbì, Elena; Sewilo, Marta "Sequential Star Formation in the Young SMC Region NGC 602: Insights from ALMA," *The Astrophysical Journal*, 938: 82, 2022.
- Ono, Yoshiaki; Fujimoto, Seiji; Harikane, Yuichi; Ouchi, Masami; Vallini, Livia; Ferrara, Andrea; Shibuya, Takatoshi; Pallottini, Andrea; Inoue, Akio K.; Imanishi, Masatoshi; Shimasaku, Kazuhiro; Hashimoto, Takuya; Lee, Chien-Hsiu; Sugahara, Yuma; Tamura, Yoichi; Kohno, Kotaro; Schramm, Malte "ALMA Observations of CO Emission from Luminous Lyman-break Galaxies at  $z = 6.0293-6.2037$ ," *The Astrophysical Journal*, 941: 74, 2022.
- Orlowski-Scherer, John; Haridas, Saianeesh K.; Di Mascolo, Luca; Sarmiento, Karen Perez; Romero, Charles E.; Dicker, Simon; Mroczkowski, Tony; Bhandarkar, Tanay; Churazov, Eugene; Clarke, Tracy E.; Devlin, Mark; Gaspari, Massimo; Lowe, Ian; Mason, Brian; Sarazin, Craig L.; Sievers, Jonathon; Sunyaev, Rashid "GBT/MUSTANG-2 9" resolution imaging of the SZ effect in MS0735.6+7421. Confirmation of the SZ cavities through direct imaging," *Astronomy and Astrophysics*, 667: L6, 2022.
- Ortega, M. E.; Marinelli, A.; Isequilla, N. L.; Paron, S. "Unveiling the substructure of the massive clump AGAL G035.1330-00.7450," *Astronomy and Astrophysics*, 658: A102, 2022.
- Osinga, E.; Van Weeren, R. J.; Andrade-Santos, F.; Rudnick, L.; Bonafede, A.; Clarke, T.; Duncan, K.; Giacintucci, S.; Mroczkowski, T.; Röttgering, H. J. A. "The detection of cluster magnetic fields via radio source depolarisation," *Astronomy and Astrophysics*, 665: A71, 2022.
- Otter, Justin Atsushi; Rowlands, Kate; Alatalo, Katherine; Leung, Ho-Hin; Wild, Vivienne; Luo, Yuanze; Petric, Andreea O.; Sazonova, Elizaveta; Stark, David V.; Heckman, Timothy; Davis, Timothy A.; Ellison, Sara; French, K. Decker; Baker, William; Bluck, Asa F. L.; Lanz, Lauranne; Lin, Lihwai; Liu, Charles; López Cobá, Carlos; Masters, Karen L.; Nair, Preethi; Pan, Hsi-An; Riffel, Rogemar A.; Scudder, Jillian M.; Smercina, Adam; Van De Voort, Freeke; Weaver, John R. "Resolved Molecular Gas Observations of MaNGA Post-starbursts Reveal a Tumultuous Past," *The Astrophysical Journal*, 941: 93, 2022.
- Paine, Jennie; Darling, Jeremy "3D Kinematics of Stellar SiO Masers in the Galactic Center," *The Astrophysical Journal*, 927: 181, 2022.
- Pajdosz-Śmierciak, Urszula; Śmierciak, Bartosz; Jamroz, Marek "Possible jet reorientation in low-frequency radio structures of blazars," *Monthly Notices of the Royal Astronomical Society*, 514: 2122, 2022.
- Pan, Hsi-An; Schinnerer, Eva; Hughes, Annie; Leroy, Adam; Groves, Brent; Barnes, Ashley Thomas; Belfiore, Francesco; Bigiel, Frank; Blanc, Guillermo A.; Cao, Yixian; Chevance, Mélanie; Congiu, Enrico; Dale, Daniel A.; Eibensteiner, Cosima; Emsellem, Eric; Faesi, Christopher M.; Glover, Simon C. O.; Grasha, Kathryn; Herrera, Cinthya N.; Ho, I.-Ting; Klessen, Ralf S.; Kruijssen, J. M. Diederik; Lang, Philipp; Liu, Daizhong; Mcelroy, Rebecca; Meidt, Sharon E.; Murphy, Eric J.; Pety, Jérôme; Querejeta, Miguel; Razza, Alessandro; Rosolowsky, Erik; Saito, Toshiki; Santoro, Francesco; Schrubba, Andreas; Sun, Jiayi; Tomičić, Neven; Usero, Antonio; Utomo, Dyas; Williams, Thomas G. "The Gas-Star Formation Cycle in Nearby Star-forming Galaxies. II. Resolved Distributions of CO and H $\alpha$  Emission for 49 PHANGS Galaxies," *The Astrophysical Journal*, 927: 9, 2022.
- Pandge, M. B.; Kale, Ruta; Dabhade, Pratik; Mahato, Mousumi; Raychaudhury, Somak "Giant Metrewave Radio Telescope unveils steep-spectrum antique filaments in the galaxy cluster Abell 725," *Monthly Notices of the Royal Astronomical Society*, 509: 1837, 2022.
- Paneque-Carreño, T.; Miotello, A.; Van Dishoeck, E. F.; Pérez, L. M.; Facchini, S.; Izquierdo, A. F.; Tychoniec, L.; Testi, L. "Vertically extended and asymmetric CN emission in the Elias 2-27 protoplanetary disk," *Astronomy and Astrophysics*, 666: A168, 2022.
- Panessa, Francesca; Chiaraluca, Elia; Bruni, Gabriele; Dallacasa, Daniele; Laor, Ari; Baldi, Ranieri D.; Behar, Ehud; Mchardy, Ian; Tombesi, Francesco; Vagnetti, Fausto "Hard-X-ray-selected active galactic nuclei - II. Spectral energy distributions in the 5-45 GHz domain," *Monthly Notices of the Royal Astronomical Society*, 515: 473, 2022.
- Panja, Alik; Sun, Yan; Chen, Wen Ping; Mondal, Soumen "Star and Cluster Formation in the Sh2-112 Filamentary Cloud Complex," *The Astrophysical Journal*, 939: 46, 2022.
- Paraschos, G. F.; Krichbaum, T. P.; Kim, J.-Y.; Hodgson, J. A.; Oh, J.; Ros, E.; Zensus, J. A.; Marscher, A. P.; Jorstad, S. G.; Gurwell, M. A.; Lähteenmäki, A.; Tornikoski, M.; Kiehlmann, S.; Readhead, A. C. S. "Jet kinematics in the transversely stratified jet of 3C 84. A two-decade overview," *Astronomy and Astrophysics*, 665: A1, 2022.
- Paré, Dylan M.; Lang, Cornelia C.; Morris, Mark R. "A Very Large Array Study of Newly Discovered Southern Latitude Nonthermal Filaments in the Galactic Center: Radio Continuum Total-intensity and Spectral Index Properties," *The Astrophysical Journal*, 941: 123, 2022.
- Parent, E.; Sewalls, H.; Freire, P. C. C.; Matheny, T.; Lyne, A. G.; Perera, B. B. P.; Cardoso, F.; Mclaughlin, M. A.; Allen, B.; Brazier, A.; Camilo, F.; Chatterjee, S.; Cordes, J. M.; Crawford, F.; Deneva, J. S.; Dong, F. A.; Ferdman, R. D.; Fonseca, E.; Hessels, J. W. T.; Kaspi, V. M.; Knispel, B.; Van Leeuwen, J.; Lynch, R. S.; Meyers, B. M.; Mckee, J. W.; Mickaliger, M. B.; Patel, C.; Ransom, S. M.; Rochon, A.; Scholz, P.; Stairs, I. H.; Stappers, B. W.; Tan, C. M.; Zhu, W. W. "Study of 72 Pulsars Discovered in the PALFA Survey: Timing Analysis, Glitch Activity, Emission Variability, and a Pulsar in an Eccentric Binary," *The Astrophysical Journal*, 924: 135, 2022.
- Parker, Raeesa; Ward-Thompson, Derek; Kirk, Jason "Taxonomy of protoplanetary discs observed with ALMA," *Monthly Notices of the Royal Astronomical Society*, 511: 2453, 2022.
- Pascale, Massimo; Frye, Brenda L.; Dai, Liang; Foo, Nicholas; Qin, Yujing; Leimbach, Reagen; Bauer, Adam Michael; Merlin, Emiliano; Coe, Dan; Diego, Jose; Yan, Haojing; Zitrin, Adi; Cohen, Seth H.; Conselice, Christopher J.; Dole, Hervé; Harrington, Kevin; Jansen, Rolf A.; Kamieneski, Patrick; Windhorst, Rogier A.; Yun, Min S. "Possible Ongoing Merger Discovered by Photometry and Spectroscopy in the Field of the Galaxy Cluster PLCK G165.7+67.0," *The Astrophysical Journal*, 932: 85, 2022.
- Pasini, T.; Edler, H. W.; Brüggem, M.; De Gasperin, F.; Botteon, A.; Rajpurohit, K.; Van Weeren, R. J.; Gastaldello, F.; Gaspari, M.; Brunetti, G.; Cuciti, V.; Nanci, C.; Di Gennaro, G.; Rossetti, M.; Dallacasa, D.; Hoang, D. N.; Riseley, C. J. "Particle re-acceleration and diffuse radio sources in the galaxy cluster Abell 1550," *Astronomy and Astrophysics*, 663: A105, 2022.
- Patil, Pallavi; Whittle, Mark; Nyland, Kristina; Lonsdale, Carol; Lacy, Mark; Kimball, Amy E.; Lonsdale, Colin; Peters, Wendy; Clarke, Tracy E.; Efstathiou, Andreas; Giacintucci, Simona; Kim, Minjin; Lanz, Lauranne; Mukherjee, Dipanjan; Polisensky, Emil "Radio Spectra of Luminous, Heavily Obscured WISE-NVSS Selected Quasars," *The Astrophysical Journal*, 934: 26, 2022.
- Peirson, A. L.; Liodakis, I.; Readhead, A. C. S.; Lister, M. L.; Perlman, E. S.; Aller, M. F.; Blandford, R. D.; Grainge, K. J. B.; Green, D. A.; Gurwell, M. A.; Hodges, M. W.; Hovatta, T.; Kiehlmann, S.; Lähteenmäki, A.; Max-Moerbeck, W.; Mcaloone, T.; O'Neill, S.; Pavlidou, V.; Pearson, T. J.; Ravi, V.; Reeves, R. A.; Scott, P. F.; Taylor, G. B.; Titterton, D. J.; Tornikoski, M.; Vedantham, H. K.; Wilkinson, P. N.; Williams, D. T.; Zensus, J. A. "New Tests of Milli-lensing in the Blazar PKS 1413 + 135," *The Astrophysical Journal*, 927: 24, 2022.
- Peng, Sijia; Li, Zhiyuan; Liu, Xin; Nyland, Kristina; Wrobel, Joan M.; Hou, Meicun "Very Large Array Multiband Radio Imaging of the Triple AGN

- Candidate SDSS J0849+1114," *The Astrophysical Journal*, 934: 89, 2022.
- Peng, Yaping; Liu, Tie; Qin, Sheng-Li; Baug, Tapas; Liu, Hong-Li; Wang, Ke; Garay, Guido; Zhang, Chao; Chen, Long-Fei; Lee, Chang Won; Juvela, Mika; Li, Dalei; Tatematsu, Ken'Ichi; Liu, Xun-Chuan; Lee, Jeong-Eun; Luo, Gan; Dewangan, Lokesh; Wu, Yue-Fang; Zhang, Li; Bronfman, Leonardo; Ge, Jixing; Tang, Mengyao; Zhang, Yong; Xu, Feng-Wei; Wang, Yao; Zhou, Bing "ATOMS: ALMA Three-millimeter Observations of Massive Star-forming regions - X. Chemical differentiation among the massive cores in G9.62+0.19," *Monthly Notices of the Royal Astronomical Society*, 512: 4419, 2022.
- Pensabene, A.; Van Der Werf, P.; Decarli, R.; Bañados, E.; Meyer, R. A.; Riechers, D.; Venemans, B.; Walter, F.; Weiß, A.; Brusa, M.; Fan, X.; Wang, F.; Yang, J. "Unveiling the warm and dense ISM in  $z > 6$  quasar host galaxies via water vapor emission," *Astronomy and Astrophysics*, 667: A9, 2022.
- Perera, B. B. P.; Smith, A. J.; Vaddi, S.; Carballo-Rubio, R.; Mcgilvray, A.; Venkataraman, A.; Roshi, D. Anish; Manoharan, P. K.; Perillat, P.; Lieb, E.; Lorimer, D. R.; McLaughlin, M. A.; Agarwal, D.; Aggarwal, K.; Ransom, S. M. "Search for fast radio transients using Arecibo drift-scan observations at 1.4 GHz," *Monthly Notices of the Royal Astronomical Society*, 509: 1929, 2022.
- Perlman, Eric S.; Meyer, Eileen T.; Wang, Q. Daniel; Yuan, Qiang; Henriksen, Richard; Irwin, Judith; Li, Jiangtao; Wiegert, Theresa; Li, Haochuan; Yang, Yang "Light-curve Evolution of the Nearest Tidal Disruption Event: A Late-time, Radio-only Flare," *The Astrophysical Journal*, 925: 143, 2022.
- Péroux, C.; Weng, S.; Karki, A.; Augustin, R.; Kulkarni, V. P.; Szakacs, R.; Klitsch, A.; Hamanowicz, A.; Fresco, A. Y.; Zwaan, M. A.; Biggs, A.; Fox, A. J.; Hayes, M.; Howk, J. C.; Kacprzak, G. G.; Kassin, S.; Kuntschner, H.; Nelson, D.; Pettini, M. "MUSE-ALMA haloes VII: survey science goals & design, data processing and final catalogues," *Monthly Notices of the Royal Astronomical Society*, 516: 5618, 2022.
- Pessa, I.; Schinnerer, E.; Leroy, A. K.; Koch, E. W.; Rosolowsky, E.; Williams, T. G.; Pan, H.-A.; Schrubba, A.; Usero, A.; Belfiore, F.; Bigiel, F.; Blanc, G. A.; Chevance, M.; Dale, D.; Emsellem, E.; Gensior, J.; Glover, S. C. O.; Grasha, K.; Groves, B.; Klessen, R. S.; Kreckel, K.; Kruijssen, J. M. D.; Liu, D.; Meidt, S. E.; Pety, J.; Querejeta, M.; Saito, T.; Sanchez-Blazquez, P.; Watkins, E. J. "Variations in the  $\Sigma_{\text{SF}} - \Sigma_{\text{mol}} - \Sigma_{\text{plane}}$  across galactic environments in PHANGS galaxies," *Astronomy and Astrophysics*, 663: A61, 2022.
- Petley, J. W.; Morabito, L. K.; Alexander, D. M.; Rankine, A. L.; Fawcett, V. A.; Rosario, D. J.; Matthews, J. H.; Shimwell, T. M.; Drabent, A. "Connecting radio emission to AGN wind properties with broad absorption line quasars," *Monthly Notices of the Royal Astronomical Society*, 515: 5159, 2022.
- Petter, Grayson C.; Hickox, Ryan C.; Alexander, David M.; Geach, James E.; Myers, Adam D.; Rosario, David J.; Fawcett, Victoria A.; Klindt, Lizelke; Whalen, Kelly E. "Host Dark Matter Halos of SDSS Red and Blue Quasars: No Significant Difference in Large-scale Environment," *The Astrophysical Journal*, 927: 16, 2022.
- Phillips, Camryn; Ransom, Scott "Algorithmic Pulsar Timing," *The Astronomical Journal*, Volume 163, 163: 12 pp., 2022.
- Pinchuk, Pavlo; Margot, Jean-Luc "A Machine Learning-based Direction-of-origin Filter for the Identification of Radio Frequency Interference in the Search for Technosignatures," *The Astronomical Journal*, 163: 76, 2022.
- Pineda, Jaime E.; Harju, Jorma; Caselli, Paola; Sipilä, Olli; Juvela, Mika; Vastel, Charlotte; Rosolowsky, Erik; Burkert, Andreas; Friesen, Rachel K.; Shirley, Yancy; Maureira, María José; Choudhury, Spandan; Segura-Cox, Dominique M.; Güsten, Rolf; Punanova, Anna; Bizzocchi, Luca; Goodman, Alyssa A. "An Interferometric View of H-MM1. I. Direct Observation of NH<sub>3</sub> Depletion," *The Astronomical Journal*, 163: 294, 2022.
- Pingel, N. M.; Dempsey, J.; McClure-Griffiths, N. M.; Dickey, J. M.; Jameson, K. E.; Arce, H.; Anglada, G.; Bland-Hawthorn, J.; Breen, S. L.; Buckland-Willis, F.; Clark, S. E.; Dawson, J. R.; Dénes, H.; Di Teodoro, E. M.; For, B.-Q.; Foster, Tyler J.; Gómez, J. F.; Imai, H.; Joncas, G.; Kim, C.-G.; Lee, M.-Y.; Lynn, C.; Leahy, D.; Ma, Y. K.; Marchal, A.; McConnell, D.; Miville-Deschênes, M.-A.; Moss, V. A.; Murray, C. E.; Nidever, D.; Peek, J.; Stanimirović, S.; Staveley-Smith, L.; Tepper-García, T.; Tremblay, C. D.; Uscanga, L.; Van Loon, J. Th.; Vázquez-Semadeni, E.; Allison, J. R.; Anderson, C. S.; Ball, Lewis; Bell, M.; Bock, D. C.-J.; Bunton, J.; Cooray, F. R.; Cornwell, T.; Koribalski, B. S.; Gupta, N.; Hayman, D. B.; Harvey-Smith, L.; Lee-Waddell, K.; Ng, A.; Phillips, C. J.; Voronkov, M.; Westmeier, T.; Whiting, M. T. "GASKAP-HI pilot survey science I: ASKAP zoom observations of HI emission in the Small Magellanic Cloud," *Publications of the Astronomical Society of Australia*, 39: e005, 2022.
- Pinilla, P.; Benisty, M.; Kurtović, N. T.; Bae, J.; Dong, R.; Zhu, Z.; Andrews, S.; Carpenter, J.; Ginski, C.; Huang, J.; Isella, A.; Pérez, L.; Ricci, L.; Rosotti, G.; Villenave, M.; Wilner, D. "Distributions of gas and small and large grains in the LkHa 330 disk trace a young planetary system," *Astronomy and Astrophysics*, 665: A128, 2022.
- Plavin, A. V.; Kovalev, Y. Y.; Pushkarev, A. B. "Direction of Parsec-scale Jets for 9220 Active Galactic Nuclei," *The Astrophysical Journal Supplement Series*, 260: 4, 2022.
- Plavin, A.; Paragi, Z.; Marcote, B.; Keimpema, A.; Hessels, J. W. T.; Nimmo, K.; Vedantham, H. K.; Spitler, L. G. "FRB 121102: Drastic changes in the burst polarization contrasts with the stability of the persistent emission," *Monthly Notices of the Royal Astronomical Society*, 511: 6033, 2022.
- Piškec, T.; Werner, N.; Grossová, R.; Topinka, M.; Simionescu, A.; Allen, S. W. "The relation between accretion rate and jet power in early-type galaxies with thermally unstable hot atmospheres," *Monthly Notices of the Royal Astronomical Society*, 517: 3682, 2022.
- Potdar, Ajay; Das, Swagat R.; Issac, Namitha; Tej, Anandmayee; Vig, Sarita; Chandra, C. H. Ishwara "Galactic H II region IRAS 17149 - 3916 - a multiwavelength study," *Monthly Notices of the Royal Astronomical Society*, 510: 658, 2022.
- Pouteau, Y.; Motte, F.; Nony, T.; Galván-Madrid, R.; Men'Shchikov, A.; Bontemps, S.; Robitaille, J.-F.; Louvet, F.; Ginsburg, A.; Herpin, F.; López-Sepulcre, A.; Dell'Ova, P.; Gusdorf, A.; Sanhueza, P.; Stutz, A. M.; Brouillet, N.; Thomasson, B.; Armante, M.; Baug, T.; Bonfand, M.; Busquet, G.; Csengeri, T.; Cunningham, N.; Fernández-López, M.; Liu, H.-L.; Olguin, F.; Towner, A. P. M.; Bally, J.; Braine, J.; Bronfman, L.; Joncour, I.; González, M.; Hennebelle, P.; Lu, X.; Menten, K. M.; Moraux, E.; Tatematsu, K.; Walker, D.; Whitworth, A. P. "ALMA-IMF. III. Investigating the origin of stellar masses: top-heavy core mass function in the W43-MM2&MM3 mini-starburst," *Astronomy and Astrophysics*, 664: A26, 2022.
- Powell, Devon M.; Vegetti, Simona; Mckean, J. P.; Spingola, Cristiana; Stacey, Hannah R.; Fassnacht, Christopher D. "A lensed radio jet at milliarcsecond resolution I: Bayesian comparison of parametric lens models," *Monthly Notices of the Royal Astronomical Society*, 516: 1808, 2022.
- Punsly, Brian; Groeneveld, Christian; Hill, Gary J.; Marziani, Paola; Zeimann, Gregory R.; Schneider, Donald P. "The Energetics of the Central Engine in the Powerful Quasar 3C 298," *The Astronomical Journal*, 163: 194, 2022.
- Purkayastha, S.; Kanekar, N.; Chengalur, J. N.; Malhotra, S.; Rhoads, J.; Ghosh, T. "A Green Pea Starburst Arising from a Galaxy-Galaxy Merger," *The Astrophysical Journal*, 933: L11, 2022.
- Qin, Sheng-Li; Liu, Tie; Liu, Xunchuan; Goldsmith, Paul F.; Li, Di; Zhang, Qizhou; Liu, Hong-Li; Wu, Yuefang; Bronfman, Leonardo; Juvela, Mika; Lee, Chang Won; Garay, Guido; Zhang, Yong; He, Jinhua; Hsu, Shih-Ying; Shen, Zhi-Qiang; Lee, Jeong-Eun; Wang, Ke; Tang, Ningyu; Tang, Mengyao; Zhang, Chao; Yue, Yinghua; Xue, Qiaowei; Li, Shanghuo; Peng, Yaping; Dutta, Somnath; Ge, Jixing; Xu, Fengwei; Chen, Long-Fei; Baug, Tapas; Dewangan, Lokesh; Tej, Anandmayee "ATOMS: ALMA Three-millimeter Observations of Massive Star-forming regions - VIII. A search for hot cores by using C2H5CN, CH3OCHO, and CH3OH lines,"

## APPENDIX A: PUBLICATIONS

- Monthly Notices of the Royal Astronomical Society, 511: 3463, 2022.
- Quici, Benjamin; Turner, Ross J.; Seymour, Nicholas; Hurley-Walker, Natasha; Shabala, Stanislav S.; Ishwara-Chandra, C. H. "Selecting and modelling remnant AGNs with limited spectral coverage," Monthly Notices of the Royal Astronomical Society, 514: 3466, 2022.
- Raiteri, Claudia M.; Carnerero, Maria I.; Balmaverde, Barbara; Bellm, Eric C.; Clarkson, William; D'Ammando, Filippo; Paolillo, Maurizio; Richards, Gordon T.; Villata, Massimo; Yoachim, Peter; Yoon, Ilsang "Blazar Variability with the Vera C. Rubin Legacy Survey of Space and Time," The Astrophysical Journal Supplement Series, 258: 3, 2022.
- Rajguru, Garima; Chatterjee, Ritaban "Moderate correlation between the accretion disk and jet power in a large sample of Fermi blazars," Physical Review D, 106: 063001, 2022.
- Rajohnson, Sambatriniaina H. A.; Frank, Bradley S.; Ponomareva, Anastasia A.; Maddox, Natasha; Kraan-Korteweg, Renã© E. C.; Jarvis, Matt J.; Adams, Elizabeth A. K.; Oosterloo, Tom; Baes, Maarten; Spekkens, Kristine; Adams, Nathan J.; Glowacki, Marcin; Kurapati, Sushma; Prandoni, Isabella; Heywood, Ian; Collier, Jordan D.; Sekhar, Srikrishna; Taylor, Russ "MIGTTEE-H I: the H I Size-Mass relation over the last billion years," Monthly Notices of the Royal Astronomical Society, 512: 2697, 2022.
- Rajpurohit, K.; Hoeft, M.; Wittor, D.; Van Weeren, R. J.; Vazza, F.; Rudnick, L.; Rajpurohit, S.; Forman, W. R.; Riseley, C. J.; Brienza, M.; Bonafede, A.; Rajpurohit, A. S.; Domínguez-Fernández, P.; Eilek, J.; Bonnassieux, E.; Brüggem, M.; Loi, F.; Röttgering, H. J. A.; Drabent, A.; Locatelli, N.; Botteon, A.; Brunetti, G.; Clarke, T. E. "Turbulent magnetic fields in the merging galaxy cluster MACS J0717.5+3745," Astronomy and Astrophysics, 657: A2, 2022.
- Rajwade, K. M.; Bezuidenhout, M. C.; Caleb, M.; Driessen, L. N.; Jankowski, F.; Malenta, M.; Morello, V.; Sanidas, S.; Stappers, B. W.; Surnis, M. P.; Barr, E. D.; Chen, W.; Kramer, M.; Wu, J.; Buchner, S.; Serylak, M.; Combes, F.; Fong, W.; Gupta, N.; Jagannathan, P.; Kilpatrick, C. D.; Krogager, J.-K.; Noterdaeme, P.; Núnëz, C.; Prochaska, J. Xavier; Srianand, R.; Tejos, N. "First discoveries and localisations of Fast Radio Bursts with MeerTRAP: a real-time, commensal MeerKAT survey," Monthly Notices of the Royal Astronomical Society, 514: pp.1961-1974, 2022.
- Ramos Almeida, C.; Bischetti, M.; García-Burillo, S.; Alonso-Herrero, A.; Audibert, A.; Ciccone, C.; Ferruglio, C.; Tadhunter, C. N.; Pierce, J. C. S.; Pereira-Santaella, M.; Bessiere, P. S. "The diverse cold molecular gas contents, morphologies, and kinematics of type-2 quasars as seen by ALMA," Astronomy and Astrophysics, 658: A155, 2022.
- Rastinejad, Jillian C.; Gompertz, Benjamin P.; Levan, Andrew J.; Fong, Wen-Fai; Nicholl, Matt; Lamb, Gavin P.; Malesani, Daniele B.; Nugent, Anya E.; Oates, Samantha R.; Tanvir, Nial R.; De Ugarte Postigo, Antonio; Kilpatrick, Charles D.; Moore, Christopher J.; Metzger, Brian D.; Ravasio, Maria Edvige; Rossi, Andrea; Schroeder, Genevieve; Jencson, Jacob; Sand, David J.; Smith, Nathan; Agüí Fernández, José Feliciano; Berger, Edo; Blanchard, Peter K.; Chornock, Ryan; Cobb, Bethany E.; De Pasquale, Massimiliano; Fynbo, Johan P. U.; Izzo, Luca; Kann, D. Alexander; Laskar, Tanmoy; Marini, Ester; Paterson, Kerry; Escorial, Alicia Rouco; Sears, Huei M.; Thöne, Christina C. "A kilonova following a long-duration gamma-ray burst at 350 Mpc," Nature, 612: 223, 2022.
- Ravi, Vikram; Dykaar, Hannah; Codd, Jackson; Zaccagnini, Ginevra; Dong, Dillon; Drout, Maria R.; Gaensler, B. M.; Hallinan, Gregg; Law, Casey "FIRST J153350.8+272729: The Radio Afterglow of a Decades-old Tidal Disruption Event," The Astrophysical Journal, 925: 220, 2022.
- Ravi, Vikram; Law, Casey J.; Li, Dongzi; Aggarwal, Kshitij; Bhardwaj, Mohit; Burke-Spolaor, Sarah; Connor, Liam; Lazio, T. Joseph W.; Simard, Dana; Somalwar, Jean; Tendulkar, Shriharsh P. "The host galaxy and persistent radio counterpart of FRB 20201124A," Monthly Notices of the Royal Astronomical Society, 513: 982, 2022.
- Ray, Paul S.; Nieder, Lars; Clark, Colin J.; Ransom, Scott M.; Cromartie, H. Thankful; Frail, Dale A.; Mooley, Kunal P.; Intema, Huib; Jagannathan, Preshanth; Demorest, Paul; Stovall, Kevin; Halpern, Jules P.; Deneva, Julia; Guillot, Sebastien; Kerr, Matthew; Swihart, Samuel J.; Bruel, Philippe; Stappers, Ben W.; Lyne, Andrew; Mickaliger, Mitch; Camilo, Fernando; Ferrara, Elizabeth C.; Wolff, Michael T.; Michelson, P. F. "Discovery, Timing, and Multiwavelength Observations of the Black Widow Millisecond Pulsar PSR J1555-2908," The Astrophysical Journal, 927: 216, 2022.
- Rebollido, Isabel; Ribas, Álvaro; De Gregorio-Monsalvo, Itziar; Villaver, Eva; Montesinos, Benjamín; Chen, Christine; Canovas, Héctor; Henning, Thomas; Moór, Attila; Perrin, Marshall; Rivière-Marichalar, Pablo; Eiroa, Carlos "The search for gas in debris discs: ALMA detection of CO gas in HD 36546," Monthly Notices of the Royal Astronomical Society, 509: 693-700, 2022.
- Redaelli, Elena; Bovino, Stefano; Sanhueza, Patricio; Morii, Kaho; Sabatini, Giovanni; Caselli, Paola; Giannetti, Andrea; Li, Shanghuo "The Core Population and Kinematics of a Massive Clump at Early Stages: An Atacama Large Millimeter/submillimeter Array View," The Astrophysical Journal, 936: 169, 2022.
- Reddy, Vishnu; Kelley, Michael S.; Dotson, Jessie; Farnocchia, Davide; Erasmus, Nicolas; Polishook, David; Masiero, Joseph; Benner, Lance A. M.; Bauer, James; Alarcon, Miguel R.; Balam, David; Bamberger, Daniel; Bell, David; Barnardi, Fabrizio; Bressi, Terry H.; Brozovic, Marina; Brucker, Melissa J.; Buzzi, Luca; Cano, Juan; Cantillo, David; Cennamo, Ramona; Chastel, Serge; Chingis, Omarov; Choi, Young-Jun; Christensen, Eric; Denneau, Larry; Drózdź, Marek; Elenin, Leonid; Erece, Orhan; Faggioli, Laura; Falco, Carmelo; Glamazda, Dmitry; Graziani, Filippo; Heinze, Aren N.; Holman, Matthew J.; Ivanov, Alexander; Jacques, Cristovao; Janse Van Rensburg, Petro; Kaiser, Galina; Kamiński, Krzysztof; Kamińska, Monika K.; Kaplan, Murat; Kim, Dong-Heun; Kim, Myung-Jin; Kiss, Csaba; Kokina, Tatiana; Kuznetsov, Eduard; Larsen, Jeffrey A.; Lee, Hee-Jae; Lees, Robert C.; De León, Julia; Licandro, Javier; Mainzer, Amy; Marciniak, Anna; Marsset, Michael; Mastaler, Ron A.; Mathias, Donovan L.; Mcmillan, Robert S.; Medeiros, Hissa; Micheli, Marco; Mokhnatkin, Artem; Moon, Hong-Kyu; Morate, David; Naidu, Shantanu P.; Nastasi, Alessandro; Novichonok, Artem; Ogloza, Waldemar; Pál, András; Pérez-Toledo, Fabricio; Perminov, Alexander; Petrescu, Elisabeta; Popescu, Marcel; Read, Mike T.; Reichart, Daniel E.; Reva, Inna; Roh, Dong-Goo; Rumpf, Clemens; Satpathy, Akash; Schmalz, Sergei; Scotti, James V.; Serebryanskiy, Aleksander; Serra-Ricart, Miquel; Sonbas, Eda; Szakáts, Robert; Taylor, Patrick A.; Tonry, John L.; Tubbiolo, Andrew F.; Veres, Peter; Wainscoat, Richard; Warner, Elizabeth; Weiland, Henry J.; Wells, Guy; Weryk, Robert; Wheeler, Lorien F.; Wiebe, Yulia; Yim, Hong-Suh; Žejmo, Michal; Zhornichenko, Anastasiya; Zoła, Stanisław; Michel, Patrick "Apophis Planetary Defense Campaign," The Planetary Science Journal, 3: 123, 2022.
- Redwing, Erin; De Pater, Imke; Luszcz-Cook, Stacia; De Kleer, Katherine; Moullet, Arielle; Rojo, Patricio M. "NaCl and KCl in Io's Atmosphere," The Planetary Science Journal, 3: 238, 2022.
- Remijan, A.; Xue, C.; Margulès, L.; Belloche, A.; Motiyenko, R. A.; Carder, J.; Codella, C.; Balucani, N.; Brogan, C. L.; Ceccarelli, C.; Hunter, T. R.; Maris, A.; Melandri, S.; Siebert, M.; Mcguire, B. A. "Expanding the submillimeter wave spectroscopy and astronomical search for thioacetamide (CH<sub>3</sub>CSNH<sub>2</sub>) in the ISM," Astronomy and Astrophysics, 658: A85, 2022.
- Rennie, Thomas J.; Harper, Stuart E.; Dickinson, Clive; Philip, Liju; Cleary, Kieran A.; Bond, Richard J.; Borowska, Jowita; Breysse, Patrick C.; Catha, Morgan; Cepeda-Arroita, Roke; Chung, Dongwoo T.; Church, Sarah E.; Dunne, Delaney A.; Eriksen, Hans Kristian; Foss, Marie Kristine; Gaier, Todd; Gundersen, Joshua Ott; Harris, Andrew I.; Hensley, Brandon; Hobbs, Richard; Ihle, Håvard T.; Lamb, James W.; Lawrence, Charles R.; Lunde, Jonas G. S.; Paladini, Roberta; Pearson, Timothy J.; Rasmussen, Maren; Readhead, Anthony C. S.; Stutzer, Nils-Ole; Watts, Duncan J.; Wehus, Ingunn Kathrine; Woody, David P.; Comap Collaboration "COMAP Early Science. VI. A First Look at the COMAP Galactic Plane Survey," The Astrophysical Journal, 933: 187, 2022.

- Retana-Montenegro, E. "What is the origin of the stacked radio emission in radio-undetected quasars?. Insights from a radio-infrared image stacking analysis," *Astronomy and Astrophysics*, 663: A153, 2022.
- Reusch, Simeon; Stein, Robert; Kowalski, Marek; Van Velzen, Sjoert; Franckowiak, Anna; Lunardini, Cecilia; Murase, Kohta; Winter, Walter; Miller-Jones, James C. A.; Kasliwal, Mansi M.; Gilfanov, Marat; Garrappa, Simone; Paliya, Vaidehi S.; Ahumada, Tomás; Anand, Shreya; Barbarino, Cristina; Bellm, Eric C.; Brinnel, Valéry; Buson, Sara; Cenko, S. Bradley; Coughlin, Michael W.; De, Kishalay; Dekany, Richard; Frederick, Sara; Gal-Yam, Avishay; Gezari, Suvi; Giroletti, Marcello; Graham, Matthew J.; Karambelkar, Viraj; Kimura, Shigeo S.; Kong, Albert K. H.; Kool, Erik C.; Laher, Russ R.; Medvedev, Pavel; Necker, Jannis; Nordin, Jakob; Perley, Daniel A.; Rigault, Mickael; Rusholme, Ben; Schulze, Steve; Schweyer, Tassilo; Singer, Leo P.; Sollerman, Jesper; Strotjohann, Nora Linn; Sunyaev, Rashid; Van Santen, Jakob; Walters, Richard; Zhang, B. Theodore; Zimmerman, Erez "Candidate Tidal Disruption Event AT2019fdr Coincident with a High-Energy Neutrino," *Physical Review Letters*, 128: 221101, 2022.
- Ricci, C.; Ananna, T. T.; Temple, M. J.; Urry, C. M.; Koss, M. J.; Trakhtenbrot, B.; Ueda, Y.; Stern, D.; Bauer, F. E.; Treister, E.; Privo, G. C.; Oh, K.; Paltani, S.; Stalevski, M.; Ho, L. C.; Fabian, A. C.; Mushotzky, R.; Chang, C. S.; Ricci, F.; Kakkad, D.; Sartori, L.; Baer, R.; Caglar, T.; Powell, M.; Harrison, F. "BASS XXXVII: The Role of Radiative Feedback in the Growth and Obscuration Properties of Nearby Supermassive Black Holes," *The Astrophysical Journal*, 938: 67, 2022.
- Ricci, Federica; Treister, Ezequiel; Bauer, Franz E.; Mejía-Restrepo, Julian E.; Koss, Michael J.; Den Brok, Jakob S.; Baloković, Mislav; Bär, Rudolf; Bessiere, Patricia; Caglar, Turgay; Harrison, Fiona; Ichikawa, Kohei; Kakkad, Darshan; Lamperti, Isabella; Mushotzky, Richard; Oh, Kyuseok; Powell, Meredith C.; Privo, George C.; Ricci, Claudio; Riffel, Rogerio; Rojas, Alejandra F.; Sani, Eleonora; Smith, Krista L.; Stern, Daniel; Trakhtenbrot, Benny; Urry, C. Megan; Veilleux, Sylvain "BASS. XXIX. The Near-infrared View of the Broad-line Region (BLR): The Effects of Obscuration in BLR Characterization," *The Astrophysical Journal Supplement Series*, 261: 8, 2022.
- Ricci, L.; Boccardi, B.; Nokhrina, E.; Perucho, M.; Macdonald, N.; Mattia, G.; Grandi, P.; Madika, E.; Krichbaum, T. P.; Zensus, J. A. "Exploring the disk-jet connection in NGC 315," *Astronomy and Astrophysics*, 664: A166, 2022.
- Rico-Villas, F.; González-Alfonso, E.; Martín-Pintado, J.; Rivilla, V. M.; Martín, S. "On the thermal structure of the proto-super star cluster 13 in NGC 253," *Monthly Notices of the Royal Astronomical Society*, 516: 1094, 2022.
- Ridolfi, A.; Freire, P. C. C.; Gautam, T.; Ransom, S. M.; Barr, E. D.; Buchner, S.; Burgay, M.; Abbate, F.; Venkatraman Krishnan, V.; Vleschower, L.; Possenti, A.; Stappers, B. W.; Kramer, M.; Chen, W.; Padmanabh, P. V.; Champion, D. J.; Bailes, M.; Levin, L.; Keane, E. F.; Breton, R. P.; Bezuidenhout, M.; Grießmeier, J.-M.; Künkel, L.; Men, Y.; Camilo, F.; Geyer, M.; Hugo, B. V.; Jameson, A.; Parthasarathy, A.; Serylak, M. "TRAPUM discovery of 13 new pulsars in NGC 1851 using MeerKAT," *Astronomy and Astrophysics*, 664: A27, 2022.
- Riechers, Dominik A.; Weiss, Axel; Walter, Fabian; Carilli, Christopher L.; Cox, Pierre; Decarli, Roberto; Neri, Roberto "Microwave background temperature at a redshift of 6.34 from H<sub>2</sub>O absorption," *Nature*, 602: 58, 2022.
- Riseley, C. J.; Rajpurohit, K.; Loi, F.; Botteon, A.; Timmerman, R.; Biava, N.; Bonafede, A.; Bonassieux, E.; Brunetti, G.; Enßlin, T.; Di Gennaro, G.; Ignesti, A.; Shimwell, T.; Stuardi, C.; Vernstrom, T.; Van Weeren, R. J. "A MeerKAT-meets-LOFAR study of MS 1455.0 + 2232: a 590 kiloparsec 'mini'-halo in a sloshing cool-core cluster," *Monthly Notices of the Royal Astronomical Society*, 512: 4210, 2022.
- Roberts, I. D.; Van Weeren, R. J.; Timmerman, R.; Botteon, A.; Gendron-Marsolais, M.; Ignesti, A.; Rottgering, H. J. A. "LoTSS jellyfish galaxies. III. The first identification of jellyfish galaxies in the Perseus cluster," *Astronomy and Astrophysics*, 658: A44, 2022.
- Roberts, Ian D.; Lang, Maojin; Trotsenko, Daria; Bemis, Ashley R.; Ellison, Sara L.; Lin, Lihwai; Pan, Hsi-An; Ignesti, Alessandro; Leslie, Sarah; Van Weeren, Reinout J. "LoTSS Jellyfish Galaxies. IV. Enhanced Star Formation in the Leading Half of Cluster Galaxies and Gas Compression in IC3949," *The Astrophysical Journal*, 941: 77, 2022.
- Rodríguez-Kamenetzky, Adriana R.; Carrasco-González, Carlos; Rodríguez, Luis F.; Ray, Tom P.; Sanna, Alberto; Moscadelli, Luca; Hoare, Melvin; Galván-Madrid, Roberto; Shang, Hsien; Lizano, Susana; Eislöffel, Jochen; Lim, Jeremy; Torrelles, José M.; Ho, Paul; Feeney-Johansson, Anton "Resolving the Collimation Zone of an Intermediate-mass Protostellar Jet," *The Astrophysical Journal*, 931: L26, 2022.
- Romani, Roger W.; Deller, Adam; Guillemot, Lucas; Ding, Hao; De Vries, Martijn; Parker, Chase; Zavala, Robert T.; Chalumeau, Aurélien; Cognard, Ismaël "The Bow Shock and Kinematics of PSR J1959+2048," *The Astrophysical Journal*, 930: 101, 2022.
- Romano, M.; Morselli, L.; Cassata, P.; Ginolfi, M.; Schaerer, D.; Béthermin, M.; Capak, P.; Faisst, A.; Le Fèvre, O.; Silverman, J. D.; Yan, L.; Bardelli, S.; Boquien, M.; Dessauges-Zavadsky, M.; Fujimoto, S.; Hathi, N. P.; Jones, G. C.; Koekemoer, A. M.; Lemaux, B. C.; Méndez-Hernández, H.; Narayanan, D.; Talia, M.; Vergani, D.; Zamorani, G.; Zucca, E. "The ALPINE-ALMA [CII] survey: The population of [CII]-undetected galaxies and their role in the L [CII]-SFR relation," *Astronomy and Astrophysics*, 660: A14, 2022.
- Rosborough, Sara A.; Robinson, A.; Seelig, T. "The kinematics and ionization structure of the extended emission-line region of QSO E1821+643," *Monthly Notices of the Royal Astronomical Society*, 515: 3319, 2022.
- Rose, Tom; Edge, Alastair; Kiehlmann, Sebastian; Baek, Junhyun; Chung, Aeere; Jung, Tae-Hyun; Kim, Jae-Woo; Readhead, Anthony C. S.; Sedgewick, Aidan "The variability of brightest cluster galaxies at high radio frequencies," *Monthly Notices of the Royal Astronomical Society*, 509: 2869, 2022.
- Roshi, D. Anish; Peters, W. M.; Emig, K. L.; Salas, P.; Oonk, J. B. R.; Lebrón, M. E.; Dickey, J. M. "Arecibo-Green Bank-LOFAR Carbon Radio Recombination Line Observations toward Cold H I Clouds," *The Astrophysical Journal*, 925: 7, 2022.
- Rota, A. A.; Manara, C. F.; Miotello, A.; Lodato, G.; Facchini, S.; Koutoulaki, M.; Herczeg, G.; Long, F.; Tazzari, M.; Cabrit, S.; Harsono, D.; Ménard, F.; Pinilla, P.; Van Der Plas, G.; Ragusa, E.; Yen, H.-W. "Observational constraints on gas disc sizes in the protoplanetary discs of multiple systems in the Taurus region," *Astronomy and Astrophysics*, 662: A121, 2022.
- Rowlinson, A.; Meijn, J.; Bright, J.; Van Der Horst, A. J.; Chastain, S.; Fijma, S.; Fender, R.; Heywood, I.; Wijers, R. A. M. J.; Woudt, P. A.; Andersson, A.; Sivakoff, G. R.; Tremou, E.; Driessen, L. N. "Search and identification of transient and variable radio sources using MeerKAT observations: a case study on the MAXI J1820+070 field," *Monthly Notices of the Royal Astronomical Society*, 517: 2894, 2022.
- Roychowdhury, Agniva; Meyer, Eileen T.; Georganopoulos, Markos; Breiding, Peter; Petropoulou, Maria "Circumnuclear Dust in AP Librae and the Source of Its VHE Emission," *The Astrophysical Journal*, 924: 57, 2022.
- Rozek, Agata; Lowry, Stephen C.; Rozitis, Benjamin; Dover, Lord R.; Taylor, Patrick A.; Virkki, Anne; Green, Simon F.; Snodgrass, Colin; Fitzsimmons, Alan; Campbell-White, Justyn; Sajadian, Sedighe; Bozza, Valerio; Burgdorf, Martin J.; Dominik, Martin; Jaimes, R. Figuera; Hinse, Tobias C.; Hundertmark, Markus; Jørgensen, Uffe G.; Longa-Peña, Penélope; Rabus, Markus; Rahvar, Sohrab; Skottfelt, Jesper; Southworth, John "Physical properties of near-Earth asteroid (2102) Tantalus from multi-wavelength observations," *Monthly Notices of the Royal Astronomical Society*, 515: 4551, 2022.
- Rudnick, L.; Brüggem, M.; Brunetti, G.; Cotton, W. D.; Forman, W.; Jones, T. W.; Nolting, C.; Schellenberger, G.; Van Weeren, R. "Intracluster Magnetic Filaments and an Encounter with a Radio Jet," *The Astrophysical Journal*, 935: 168, 2022.
- Ruffa, Ilaria; Prandoni, Isabella; Davis, Timothy A.; Laing, Robert A.; Paladino, Rosita; Casasola, Viviana; Parma, Paola; Bureau, Martin "The AGN

## APPENDIX A: PUBLICATIONS

- fuelling/feedback cycle in nearby radio galaxies - IV. Molecular gas conditions and jet-ISM interaction in NGC 3100," *Monthly Notices of the Royal Astronomical Society*, 510: 4485, 2022.
- Ruiz-Carmona, R.; Sfaradi, I.; Horesh, A. "Type IIP supernova SN2016X in radio frequencies," *Astronomy and Astrophysics*, 666: A82, 2022.
- Ruiz-Rodríguez, D. A.; Williams, J. P.; Kastner, J. H.; Cieza, L.; Leemker, M.; Principe, D. A. "A chemical map of the outbursting V883 Ori system: Vertical and radial structures," *Monthly Notices of the Royal Astronomical Society*, 515: 2646, 2022.
- Ruiz-Rodríguez, Dary A.; Cieza, Lucas A.; Casassus, Simon; Almendros-Abad, Victor; Jofré, Paula; Muzic, Koraljka; Ramirez, Karla Peña; Batalla-Falcon, Grace; Dunham, Michael M.; González-Ruilova, Camilo; Hales, Antonio; Humphreys, Elizabeth; Nogueira, Pedro H.; Paladini, Claudia; Tobin, John; Williams, Jonathan P.; Zurlo, Alice "Discovery of a Brown Dwarf with Quasi-spherical Mass Loss," *The Astrophysical Journal*, 938: 54, 2022.
- Runburg, Jack; Farrah, Duncan; Sajina, Anna; Lacy, Mark; Lidua, Jenna; Hatziminaoglou, Evanthia; Brandt, W. N.; Chen, Chien-Ting J.; Nyland, Kristina; Shirley, Raphael; Clements, D. L.; Pitchford, Lura K. "Consistent Analysis of the AGN LF in X-Ray and MIR in the XMM-LSS Field," *The Astrophysical Journal*, 924: 133, 2022.
- Rybak, M.; Hodge, J. A.; Greve, T. R.; Riechers, D.; Lamperti, I.; Van Marrewijk, J.; Walter, F.; Wagg, J.; Van Der Werf, P. P. "PRUSSIC. I. A JVLA survey of HCN, HCO+, and HNC (1-0) emission in z ~ 3 dusty galaxies: Low dense-gas fractions in high-redshift star-forming galaxies," *Astronomy and Astrophysics*, 667: A70, 2022.
- Rybarczyk, Daniel R.; Gong, Munan; Stanimirović, Snežana; Babler, Brian; Murray, Claire E.; Winters, Jan Martin; Luo, Gan; Dame, T. M.; Steffes, Lucille "The Role of Neutral Hydrogen in Setting the Abundances of Molecular Species in the Milky Way's Diffuse Interstellar Medium. II. Comparison between Observations and Theoretical Models," *The Astrophysical Journal*, 926: 190, 2022.
- Rybarczyk, Daniel R.; Stanimirović, Snežana; Gong, Munan; Babler, Brian; Murray, Claire E.; Gerin, Maryvonne; Winters, Jan Martin; Luo, Gan; Dame, T. M.; Steffes, Lucille "The Role of Neutral Hydrogen in Setting the Abundances of Molecular Species in the Milky Way's Diffuse Interstellar Medium. I. Observational Constraints from ALMA and NOEMA," *The Astrophysical Journal*, 928: 79, 2022.
- Sabatini, Giovanni; Bovino, Stefano; Sanhueza, Patricio; Morii, Kaho; Li, Shanghuo; Redaelli, Elena; Zhang, Qizhou; Lu, Xing; Feng, Siyi; Tafuya, Daniel; Izumi, Natsuko; Sakai, Takeshi; Tatematsu, Ken'ichi; Allingham, David "The ALMA Survey of 70  $\mu$ m Dark High-mass Clumps in Early Stages (ASHES). VI. The Core-scale CO Depletion," *The Astrophysical Journal*, 936: 80, 2022.
- Saberi, M.; Khouri, T.; Veilla-Prieto, L.; Fonfría, J. P.; Vlemmings, W. H. T.; Wedemeyer, S. "First detection of AIF line emission towards M-type AGB stars," *Astronomy and Astrophysics*, 663: A54, 2022.
- Saha, Anindya; Tej, Anandmayee; Liu, Hong-Li; Liu, Tie; Issac, Namitha; Lee, Chang Won; Garay, Guido; Goldsmith, Paul F.; Juvela, Mika; Qin, Sheng-Li; Stutz, Amelia; Li, Shanghuo; Wang, Ke; Baug, Tapas; Bronfman, Leonardo; Xu, Feng-Wei; Zhang, Yong; Eswaraiiah, Chakali "ATOMS: ALMA three-millimeter observations of massive star-forming regions - XII: Fragmentation and multiscale gas kinematics in protoclusters G12.42+0.50 and G19.88-0.53," *Monthly Notices of the Royal Astronomical Society*, 516: 1983, 2022.
- Sahai, R.; Huang, P.-S.; Scibelli, S.; Morris, M. R.; Hinkle, K.; Lee, C.-F. "The Rapidly Evolving Asymptotic Giant Branch Star, V Hya: ALMA Finds a Multiring Circus with High-velocity Outflows," *The Astrophysical Journal*, 929: 59, 2022.
- Sai, Jinshi; Ohashi, Nagayoshi; Maury, Anaëlle J.; Maret, Sébastien; Yen, Hsi-Wei; Aso, Yusuke; Gaudel, Mathilde "Which Part of Dense Cores Feeds Material to Protostars? The Case of L1489 IRS," *The Astrophysical Journal*, 925: 12, 2022.
- Saito, Toshiki; Takano, Shuro; Harada, Nanase; Nakajima, Taku; Schinnerer, Eva; Liu, Daizhong; Taniguchi, Akio; Izumi, Takuma; Watanabe, Yumi; Bamba, Kazuharu; Herbst, Eric; Kohno, Kotaro; Nishimura, Yuri; Stuber, Sophia; Tamura, Yoichi; Tosaki, Tomoka "The Kiloparsec-scale Neutral Atomic Carbon Outflow in the Nearby Type 2 Seyfert Galaxy NGC 1068: Evidence for Negative AGN Feedback," *The Astrophysical Journal*, 927: L32, 2022.
- Saito, Toshiki; Takano, Shuro; Harada, Nanase; Nakajima, Taku; Schinnerer, Eva; Liu, Daizhong; Taniguchi, Akio; Izumi, Takuma; Watanabe, Yumi; Yumi; Bamba, Kazuharu; Kohno, Kotaro; Nishimura, Yuri; Stuber, Sophia; Tosaki, Tomoka "AGN-driven Cold Gas Outflow of NGC 1068 Characterized by Dissociation-sensitive Molecules," *The Astrophysical Journal*, 935: 155, 2022.
- Sajina, Anna; Lacy, Mark; Pope, Alexandra "The Past and Future of Mid-Infrared Studies of AGN," *Universe*, 8: 356, 2022.
- Sakai, Takeshi; Sanhueza, Patricio; Furuya, Kenji; Tatematsu, Ken'ichi; Li, Shanghuo; Aikawa, Yuri; Lu, Xing; Zhang, Qizhou; Morii, Kaho; Nakamura, Fumitaka; Takemura, Hideaki; Izumi, Natsuko; Hirota, Tomoya; Silva, Andrea; Guzman, Andres E.; Sakai, Nami; Yamamoto, Satoshi "The ALMA Survey of 70  $\mu$ m Dark High-mass Clumps in Early Stages (ASHES). V. Deuterated Molecules in the 70  $\mu$ m Dark IRDC G14.492-00.139," *The Astrophysical Journal*, 925: 144, 2022.
- Salafia, Om Sharan; Ravaio, Maria Edvige; Yang, Jun; An, Tao; Orienti, Monica; Ghirlanda, Giancarlo; Nava, Lara; Giroletti, Marcello; Mohan, Prashanth; Spinelli, Riccardo; Zhang, Yingkang; Marcote, Benito; Cimò, Giuseppe; Wu, Xuefeng; Li, Zhixuan "Multiwavelength View of the Close-by GRB 190829A Sheds Light on Gamma-Ray Burst Physics," *The Astrophysical Journal*, 931: L19, 2022.
- Salvestrini, F.; Gruppioni, C.; Hatziminaoglou, E.; Pozzi, F.; Vignali, C.; Casasola, V.; Paladino, R.; Aalto, S.; Andreani, P.; Marchesi, S.; Stanke, T. "The molecular gas properties in local Seyfert 2 galaxies," *Astronomy and Astrophysics*, 663: A28, 2022.
- Samudre, Ashwin; George, Lijo T.; Bansal, Mahak; Wadadekar, Yogesh "Data-efficient classification of radio galaxies," *Monthly Notices of the Royal Astronomical Society*, 509: 2269, 2022.
- Samuel, Joseph; Nityananda, Rajaram; Thyagarajan, Nithyanandan "Invariants in Polarimetric Interferometry: A Non-Abelian Gauge Theory," *Physical Review Letters*, 128: 091101, 2022.
- Sanchez Contreras, C.; Alcolea, J.; Rodriguez Cardoso, R.; Bujarrabal, V.; Castro-Carrizo, A.; Quintana-Lacaci, G.; Veilla-Prieto, L.; Santander-García, M. "Dissecting the central regions of OH 231.8+4.2 with ALMA: A salty rotating disk at the base of a young bipolar outflow," *Astronomy and Astrophysics*, 665: A88, 2022.
- Sánchez-García, M.; García-Burillo, S.; Pereira-Santaella, M.; Colina, L.; Usero, A.; Querejeta, M.; Alonso-Herrero, A.; Fuente, A. "Spatially resolved star-formation relations of dense molecular gas in NGC 1068," *Astronomy and Astrophysics*, 660: A83, 2022.
- Sánchez-García, M.; Pereira-Santaella, M.; García-Burillo, S.; Colina, L.; Alonso-Herrero, A.; Villar-Martín, M.; Saito, T.; Díaz-Santos, T.; Piqueras López, J.; Arribas, S.; Bellocchi, E.; Cazzoli, S.; Labiano, A. "Duality in spatially resolved star formation relations in local LIRGs," *Astronomy and Astrophysics*, 659: A102, 2022.
- Sand, Ketan R.; Faber, Jakob T.; Gajjar, Vishal; Michilli, Daniele; Andersen, Bridget C.; Joshi, Bhal Chandra; Kudale, Sanjay; Pilia, Maura; Brzycki, Bryan; Cassanelli, Tomas; Croft, Steve; Dey, Biprateep; John, Hoang; Leung, Calvin; Mckinven, Ryan; Ng, Cherry; Pearlman, Aaron B.; Petroff, Emily; Price, Danny C.; Siemion, Andrew; Smith, Kendrick; Tendulkar, Shriharsh P. "Multiband Detection of Repeating FRB 20180916B," *The Astrophysical Journal*, 932: 98, 2022.
- Sanz-Novo, M.; Alonso, J. L.; Rivilla, V. M.; Mcguire, B. A.; León, I.; Mata, S.; Jimenez-Serra, I.; Martín-Pintado, J. "Laboratory detection and astronomical study of interstellar acetohydroxamic acid, a glycine isomer," *Astronomy and Astrophysics*, 666: A134, 2022.
- Sanz-Novo, M.; Belloche, A.; Rivilla, V. M.; Garrod, R. T.; Alonso, J. L.; Redondo, P.; Barrientos, C.; Kolesniková, L.; Valle, J. C.; Rodríguez-Almeida, L.; Jimenez-Serra, I.; Martín-Pintado, J.; Müller, H. S. P.; Menten, K. M. "Toward the limits of complexity of interstellar chemistry:

- Rotational spectroscopy and astronomical search for n- and i-butanol," *Astronomy and Astrophysics*, 666: A114, 2022.
- Sargent, Andrew J.; Johnson, Megan C.; Reines, Amy E.; Secrest, Nathan J.; Van Der Horst, Alexander J.; Cigan, Phil J.; Darling, Jeremy; Greene, Jenny E. "Wandering Black Hole Candidates in Dwarf Galaxies at VLBI Resolution," *The Astrophysical Journal*, 933: 160, 2022.
- Sasikumar, Silpa; Kharb, P.; Harrison, C. M.; Girdhar, A.; Mukherjee, D.; Mainieri, V.; Jarvis, M. E. "The Quasar Feedback Survey: Revealing the interplay of jets, winds & emission line gas in Type 2 quasars with radio polarization," *Monthly Notices of the Royal Astronomical Society*, 513: 4208, 2022.
- Sasmal, Tapan K.; Bera, Soumen; Pal, Sabyasachi; Mondal, Soumen "A New Catalog of Head-Tail Radio Galaxies from the VLA FIRST Survey," *The Astrophysical Journal Supplement Series*, 259: 31, 2022.
- Satapathy, Kaushik; Psaltis, Dimitrios; Özel, Feryal; Medeiros, Lia; Dougall, Sean T.; Chan, Chi-Kwan; Wielgus, Maciek; Prather, Ben S.; Wong, George N.; Gammie, Charles F.; Akiyama, Kazunori; Alberdi, Antxon; Alef, Walter; Algaba, Juan Carlos; Anantua, Richard; Asada, Keiichi; Azulay, Rebecca; Baczkó, Anne-Kathrin; Ball, David; Baloković, Mislav; Barrett, John; Benson, Bradford A.; Bintley, Dan; Blackburn, Lindy; Blundell, Raymond; Boland, Wilfred; Bouman, Katherine L.; Bower, Geoffrey C.; Boyce, Hope; Bremer, Michael; Brinkerink, Christiaan D.; Brissenden, Roger; Britzen, Silke; Broderick, Avery E.; Brogiere, Dominique; Bronzwaer, Thomas; Bustamente, Sandra; Byun, Do-Young; Carlstrom, John E.; Chael, Andrew; Chatterjee, Koushik; Chatterjee, Shami; Chen, Ming-Tang; Chen, Yongjun; Cho, Ilje; Christian, Pierre; Conway, John E.; Cordes, James M.; Crawford, Thomas M.; Crew, Geoffrey B.; Cruz-Osorio, Alejandro; Cui, Yuzhu; Davelaar, Jordy; De Laurentis, Mariafelicia; Deane, Roger; Dempsey, Jessica; Desvignes, Gregory; Dexter, Jason; Doleman, Sheperd S.; Eatough, Ralph P.; Falcke, Heino; Farah, Joseph; Fish, Vincent L.; Fomalont, Ed; Ford, H. Alyson; Fraga-Encinas, Raquel; Friberg, Per; Fromm, Christian M.; Fuentes, Antonio; Galison, Peter; García, Roberto; Gentz, Olivier; Georgiev, Boris; Goddi, Ciriaco; Gold, Roman; Gómez-Ruiz, Arturo I.; Gómez, José L.; Gu, Minfeng; Gurwell, Mark; Hada, Kazuhiro; Haggard, Daryl; Hecht, Michael H.; Hesper, Ronald; Ho, Luis C.; Ho, Paul; Honma, Mareki; Huang, Chih-Wei L.; Huang, Lei; Hughes, David H.; Ikeda, Shiro; Inoue, Makoto; Issaoun, Sara; James, David J.; Jannuzi, Buell T.; Janssen, Michael; Jeter, Britton; Jiang, Wu; Jimenez-Rosales, Alejandra; Johnson, Michael D.; Jorstad, Svetlana; Jung, Taehyun; Karami, Mansour; Karuppusamy, Ramesh; Kawashima, Tomohisa; Keating, Garrett K.; Kettenis, Mark; Kim, Dong-Jin; Kim, Jae-Young; Kim, Jongsoo; Kim, Junhan; Kino, Motoki; Koay, Jun Yi; Kofuji, Yutaro; Koch, Patrick M.; Koyama, Shoko; Kramer, Carsten; Kramer, Michael; Krichbaum, Thomas P.; Kuo, Cheng-Yu; Lauer, Tod R.; Lee, Sang-Sung; Levis, Aviad; Li, Yan-Rong; Li, Zhiyuan; Lindqvist, Michael; Lico, Rocco; Lindahl, Greg; Liu, Jun; Liu, Kuo; Liuzzo, Elisabetta; Lo, Wen-Ping; Lobanov, Andrei P.; Loinard, Laurent; Lonsdale, Colin; Lu, Ru-Sen; Macdonald, Nicholas R.; Mao, Jirong; Marchili, Nicola; Markoff, Sera; Marrone, Daniel P.; Marscher, Alan P.; Martí-Vidal, Iván; Matsushita, Satoki; Matthews, Lynn D.; Menten, Karl M.; Mizuno, Izumi; Mizuno, Yosuke; Moran, James M.; Moriyama, Kotaro; Moscibrodzka, Monika; Müller, Cornelia; Mejías, Alejandro Mus; Musoke, Gibwa; Nagai, Hiroshi; Nagar, Neil M.; Nakamura, Masanori; Narayan, Ramesh; Narayanan, Gopal; Natarajan, Iniyán; Nathanail, Antonios; Neilsen, Joey; Neri, Roberto; Ni, Chunchong; Noutsos, Aristeidis; Nowak, Michael A.; Okino, Hiroki; Olivares, Héctor; Ortiz-León, Gisela N.; Oyama, Tomoaki; Palumbo, Daniel C. M.; Park, Jongho; Patel, Nimesh; Pen, Ue-Li; Pesce, Dominic W.; Piétu, Vincent; Plambeck, Richard; Popstefanija, Aleksandar; Porth, Oliver; Pötzel, Felix M.; Preciado-López, Jorge A.; Pu, Hung-Yi; Ramakrishnan, Venkatesh; Rao, Ramprasad; Rawlings, Mark G.; Raymond, Alexander W.; Rezzolla, Luciano; Ripperda, Bart; Roelofs, Freek; Rogers, Alan; Ros, Eduardo; Rose, Mel; Roshanineshat, Arash; Rottmann, Helge; Roy, Alan L.; Ruszczyk, Chet; Rygl, Kazi L. J.; Sánchez, Salvador; Sánchez-Argüelles, David; Sasada, Mahito; Savolainen, Tuomas; Schloerb, F. Peter; Schuster, Karl-Friedrich; Shao, Lijing; Shen, Zhiqiang; Small, Des; Sohn, Bong Won; Soohoo, Jason; Sun, He; Tazaki, Fumie; Tetarenko, Alexandra J.; Tiede, Paul; Tilanus, Remo P. J.; Titus, Michael; Toma, Kenji; Torne, Pablo; Traianou, Efthalia; Trent, Tyler; Trippe, Sascha; Van Bemmell, Ilse; Van Langevelde, Huib Jan; Van Rossum, Daniel R.; Wagner, Jan; Ward-Thompson, Derek; Wardle, John; Weintraub, Jonathan; Wex, Norbert; Wharton, Robert; Wiik, Kaj; Wu, Qingwen; Yoon, Doosoo; Young, André; Young, Ken; Younsi, Ziri; Yuan, Feng; Yuan, Ye-Fei; Zensus, J. Anton; Zhao, Guang-Yao; Zhao, Shan-Shan "The Variability of the Black Hole Image in M87 at the Dynamical Timescale," *The Astrophysical Journal*, 925: 13, 2022.
- Satyal, Suman; Quarles, Billy; Rosario-Franco, Marialis "Moon packing around an Earth-mass planet," *Monthly Notices of the Royal Astronomical Society*, 516: 39, 2022.
- Schlegel, E. M.; Lacey, C. K.; Pannuti, Thomas G.; Lozinskaya, T.; Moiseev, A. "The Nearby Dwarf Irregular Galaxy IC 1613 and Its Complex Bubble Region: Chandra and VLA Observations," *The Astronomical Journal*, 163: 66, 2022.
- Schouws, Sander; Stefanon, Mauro; Bouwens, Rychard; Smit, Renske; Hodge, Jacqueline; Labbé, Ivo; Algera, Hiddo; Boogaard, Leindert; Carniani, Stefano; Fudamoto, Yoshinobu; Holwerda, Benne W.; Illingworth, Garth D.; Maiolino, Roberto; Maseda, Michael; Oesch, Pascal; Van Der Werf, Paul "Significant Dust-obscured Star Formation in Luminous Lyman-break Galaxies at z 7-8," *The Astrophysical Journal*, 928: 31, 2022.
- Schroeder, Genevieve; Laskar, Tanmoy; Fong, Wen-Fai; Nugent, Anya E.; Berger, Edo; Chornock, Ryan; Alexander, Kate D.; Andrews, Jennifer; Bussmann, R. Shane; Castro-Tirado, Alberto J.; Goyal, Armaan V.; Kilpatrick, Charles D.; Lally, Maura; Miller, Adam A.; Milne, Peter; Paterson, Kerry; Escorial, Alicia Rouco; Stroh, Michael C.; Terreran, Giacomo; Zauderer, Bevin Ashley "A Radio-selected Population of Dark, Long Gamma-Ray Bursts: Comparison to the Long Gamma-Ray Burst Population and Implications for Host Dust Distributions," *The Astrophysical Journal*, 940: 53, 2022.
- Schuessler, Caden; Remijan, Anthony; Xue, Ci; Carder, Joshua; Scolati, Haley; Mcguire, Brett "Searching for Propionamide (C2H5CONH2) toward Sagittarius B2 at Centimeter Wavelengths," *The Astrophysical Journal*, 941: 102, 2022.
- Scott, T. C.; Cortese, L.; Lagos, P.; Brinks, E.; Finoguenov, A.; Coccatto, L. "FGC 1287 and its enigmatic 250 kpc long HI tail in the outskirts of Abell 1367," *Monthly Notices of the Royal Astronomical Society*, 511: 980, 2022.
- Sebastian, Biny; Kharb, Preeti; Lister, Matthew L.; Marshall, Herman L.; O'Dea, Christopher P.; Baum, Stefi A. "Investigating the Origin of X-Ray Jets: A Case Study of Four Hybrid Morphology MOJAVE Blazars," *The Astrophysical Journal*, 935: 59, 2022.
- Secrest, Nathan J.; Von Hausegger, Sebastian; Rameez, Mohamed; Mohayae, Roya; Sarkar, Subir "A Challenge to the Standard Cosmological Model," *The Astrophysical Journal*, 937: L31, 2022.
- Sekhar, Srikrishna; Jagannathan, Preshanth; Kirk, Brian; Bhatnagar, Sanjay; Taylor, Russ "Direction-dependent Corrections in Polarimetric Radio Imaging. III. A-to-Z Solver-Modeling the Full Jones Antenna Aperture Illumination Pattern," *The Astronomical Journal*, 163: 87, 2022.
- Sewiło, Marta; Cordiner, Martin; Charnley, Steven B.; Oliveira, Joana M.; Garcia-Berrios, Emmanuel; Schilke, Peter; Ward, Jacob L.; Wiseman, Jennifer; Indebetouw, Remy; Tokuda, Kazuki; Van Loon, Jacco Th.; Sánchez-Monge, Álvaro; Allen, Veronica; Chen, C. -H. Rosie; Hamedani Golshan, Roya; Karska, Agata; Kristensen, Lars E.; Kurtz, Stan E.; Möller, Thomas; Onishi, Toshikazu; Zahorec, Sarolta "ALMA Observations of Molecular Complexity in the Large Magellanic Cloud: The N 105 Star-forming Region," *The Astrophysical Journal*, 931: 102, 2022.
- Sewiło, Marta; Karska, Agata; Kristensen, Lars E.; Charnley, Steven B.; Chen, C. -H. Rosie; Oliveira, Joana M.; Cordiner, Martin; Wiseman, Jennifer; Sánchez-Monge, Álvaro; Van Loon, Jacco Th.; Indebetouw, Remy; Schilke, Peter; Garcia-Berrios, Emmanuel "The Detection of Deuterated

## APPENDIX A: PUBLICATIONS

- Water in the Large Magellanic Cloud with ALMA," *The Astrophysical Journal*, 933: 64, 2022.
- Shanahan, Russell; Stil, Jeroen M.; Anderson, Loren; Beuther, Henrik; Goldsmith, Paul; Ott, Jürgen; Rugel, Michael; Soler, Juan; Syed, Jonas "Polarized Emission from Four Supernova Remnants in the THOR Survey," *The Astrophysical Journal*, 939: 92, 2022.
- Shao, Chengyu; Cheng, Xiaopeng; Thomas, Tam, Pak-Hin; Yang, Lili; Cui, Yudong; Pal, Partha Sarathi; Zhang, Zhongli; Sohn, Bong Won; Sugiyama, Koichiro; Chen, Wen; Hao, Longfei "Is Fermi 1544-0649 a Misaligned Blazar? Discovering the Jet Structure with Very Long Baseline Interferometry," *The Astrophysical Journal*, 934: 39, 2022.
- Shao, Yali; Wagg, Jeff; Wang, Ran; Momjian, Emmanuel; Carilli, Chris L.; Walter, Fabian; Riechers, Dominik A.; Intema, Huib T.; Weiss, Axel; Brunthaler, Andreas; Menten, Karl M. "The radio spectral turnover of radio-loud quasars at  $z > 5$ ," *Astronomy and Astrophysics*, 659: A159, 2022.
- Shao, Yali; Wang, Ran; Weiss, Axel; Wagg, Jeff; Carilli, Chris L.; Strauss, Michael A.; Walter, Fabian; Cox, Pierre; Fan, Xiaohui; Menten, Karl M.; Narayanan, Desika; Riechers, Dominik; Bertoldi, Frank; Omont, Alain; Jiang, Linhua "The interstellar medium distribution, gas kinematics, and system dynamics of the far-infrared luminous quasar SDSS J2310+1855 at  $z = 6.0$ ," *Astronomy and Astrophysics*, 668: A121, 2022.
- Sharda, Piyush; Menon, Shyam H.; Federrath, Christoph; Krumholz, Mark R.; Beattie, James R.; Jameson, Katherine E.; Tokuda, Kazuki; Burkhart, Blakesley; Crocker, Roland M.; Law, Charles J.; Seta, Amit; Gaetz, Terrance J.; Pingel, Nickolas M.; Seitzzahl, Ivo R.; Sano, Hidetoshi; Fukui, Yasuo "First extragalactic measurement of the turbulence driving parameter: ALMA observations of the star-forming region N159E in the Large Magellanic Cloud," *Monthly Notices of the Royal Astronomical Society*, 509: 2180, 2022.
- Sharma, Shyam S.; Roy, Jayanta; Bhattacharyya, Bhaswati; Levin, Lina; Stappers, Ben W.; Pennucci, Timothy T.; Schult, Levi; Singh, Shubham; Kaninghat, Aswathy "Wide-band Timing of GMRT-discovered Millisecond Pulsars," *The Astrophysical Journal*, 936: 86, 2022.
- Sheehan, Patrick D.; Tobin, John J.; Li, Zhi-Yun; Van'T Hoff, Merel L. R.; Jørgensen, Jes K.; Kwon, Woojin; Looney, Leslie W.; Ohashi, Nagayoshi; Takakuwa, Shigehisa; Williams, Jonathan P.; Aso, Yusuke; Gavino, Sacha; Gregorio-Monsalvo, Itziar De; Han, Ilseung; Lee, Chang Won; Plunkett, Adele; Sharma, Rajeeb; Aikawa, Yuri; Lai, Shih-Ping; Lee, Jeong-Eun; Lin, Zhe-Yu Daniel; Saigo, Kazuya; Tomida, Kengo; Yen, Hsi-Wei "A VLA View of the Flared, Asymmetric Disk around the Class 0 Protostar L1527 IRS," *The Astrophysical Journal*, 934: 95, 2022.
- Sheehan, Patrick D.; Tobin, John J.; Looney, Leslie W.; Megeath, S. Thomas "The VLA/ALMA Nascent Disk and Multiplicity (VANDAM) Survey of Orion Protostars. VI. Insights from Radiative Transfer Modeling," *The Astrophysical Journal*, 929: 76, 2022.
- Shen, Lu; Lemaux, Brian C.; Lubin, Lori M.; Liu, Guilin; Béthermin, Matthieu; Boquien, Médéric; Cucciati, Olga; Le Fèvre, Olivier; Talia, Margherita; Vergani, Daniela; Zamorani, Gianni; Faisst, Andreas L.; Ginolfi, Michele; Gruppioni, Carlotta; Jones, Gareth C.; Bardelli, Sandro; Hathi, Nimish; Koekemoer, Anton M.; Romano, Michael; Schaerer, Daniel; Zucca, Elena; Fang, Wenjuan; Forrest, Ben; Gal, Roy; Hung, Denise; Shah, Ekta A.; Staab, Priti; Vanderhoof, Brittany; Ibar, Eduardo "The ALPINE-ALMA [C II] Survey: The Infrared-Radio Correlation and Active Galactic Nucleus Fraction of Star-forming Galaxies at  $z = 4.4$ - $5.9$ ," *The Astrophysical Journal*, 935: 177, 2022.
- Shimwell, T. W.; Hardcastle, M. J.; Tasse, C.; Best, P. N.; Röttgering, H. J. A.; Williams, W. L.; Botteon, A.; Drabent, A.; Mechev, A.; Shulevski, A.; Van Weeren, R. J.; Bester, L.; Brüggén, M.; Brunetti, G.; Callingham, J. R.; Chyży, K. T.; Conway, J. E.; Dijkema, T. J.; Duncan, K.; De Gasperin, F.; Hale, C. L.; Haverkorn, M.; Hugo, B.; Jackson, N.; Mevius, M.; Miley, G. K.; Morabito, L. K.; Morganti, R.; Offringa, A.; Oonk, J. B. R.; Rafferty, D.; Sabater, J.; Smith, D. J. B.; Schwarz, D. J.; Smirnov, O.; O'Sullivan, S. P.; Vedantham, H.; White, G. J.; Albert, J. G.; Alegre, L.; Asabere, B.; Bacon, D. J.; Bonafede, A.; Bonnassieux, E.; Brienza, M.; Bilicki, M.; Bonato, M.; Calistro Rivera, G.; Cassano, R.; Cochrane, R.; Croston, J. H.; Cuciti, V.; Dallacasa, D.; Danezi, A.; Dettmar, R. J.; Di Gennaro, G.; Edler, H. W.; Enßlin, T. A.; Emig, K. L.; Franzen, T. M. O.; García-Vergara, C.; Grange, Y. G.; Gürkan, G.; Hajduk, M.; Heald, G.; Heesen, V.; Hoang, D. N.; Hoefl, M.; Horellou, C.; Iacobelli, M.; Jamroz, M.; Jelić, V.; Kondapally, R.; Kukreti, P.; Kunert-Bajraszewska, M.; Magliocchetti, M.; Mahatma, V.; Małek, K.; Mandal, S.; Massaro, F.; Meyer-Zhao, Z.; Mingo, B.; Mostert, R. I. J.; Nair, D. G.; Nakoneczny, S. J.; Nikiel-Wroczyński, B.; Orrù, E.; Pajdosz-Śmierciak, U.; Pasini, T.; Prandoni, I.; Van Piggelen, H. E.; Rajpurohit, K.; Retana-Montenegro, E.; Riseley, C. J.; Rowlinson, A.; Saxena, A.; Schrijvers, C.; Sweijen, F.; Siewert, T. M.; Timmerman, R.; Vaccari, M.; Vink, J.; West, J. L.; Wołowska, A.; Zhang, X.; Zheng, J. "The LOFAR Two-metre Sky Survey. V. Second data release," *Astronomy and Astrophysics*, 659: A1, 2022.
- Shivaei, Irene; Popping, Gergő; Rieke, George; Reddy, Naveen; Pope, Alexandra; Kennicutt, Robert; Mobasher, Bahram; Coil, Alison; Fudamoto, Yoshinobu; Kriek, Mariska; Lyu, Jianwei; Oesch, Pascal; Sanders, Ryan; Shapley, Alice; Siana, Brian "Infrared Spectral Energy Distributions and Dust Masses of Sub-solar Metallicity Galaxies at  $z = 2.3$ ," *The Astrophysical Journal*, 928: 68, 2022.
- Shu, Xinwen; Yang, Lei; Liu, Daizhong; Wang, Wei-Hao; Wang, Tao; Han, Yunkun; Huang, Xingxing; Lim, Chen-Fatt; Chang, Yu-Yen; Zheng, Wei; Zheng, Xianzhong; Wang, Junxian; Kong, Xu "A Census of Optically Dark Massive Galaxies in the Early Universe from Magnification by Lensing Galaxy Clusters," *The Astrophysical Journal*, 926: 155, 2022.
- Shukla, Gitika; Srianand, Raghunathan; Gupta, Neeraj; Petitjean, Patrick; Baker, Andrew J.; Krogager, Jens-Kristian; Noterdaeme, Pasquier "Spatially resolved Lyman- $\alpha$  emission around radio bright quasars," *Monthly Notices of the Royal Astronomical Society*, 510: 786, 2022.
- Shuvo, Onic I.; Johnson, Megan C.; Secrest, Nathan J.; Gliozzi, Mario; Fischer, Travis C.; Cigan, Phillip J.; Fernandez, Luis C.; Dorland, Bryan N. "FRAMEx. III. Radio Emission in the Immediate Vicinity of Radio-quiet AGNs," *The Astrophysical Journal*, 936: 76, 2022.
- Siebert, Mark A.; Lee, Kin Long Kelvin; Remijan, Anthony J.; Burkhardt, Andrew M.; Burkhardt, Andrew M.; Loomis, Ryan A.; McCarthy, Michael C.; McGuire, Brett A.; Gotham Collaboration "CH3-Terminated Carbon Chains in the GOTHAM Survey of TMC-1: Evidence of Interstellar CH3C7N," *The Astrophysical Journal*, 924: 21, 2022.
- Siebert, Mark A.; Van De Sande, Marie; Millar, Thomas J.; Remijan, Anthony J. "Investigating Anomalous Photochemistry in the Inner Wind of IRC+10216 through Interferometric Observations of HC3N," *The Astrophysical Journal*, 941: 90, 2022.
- Silassen, Nikolaj B.; Jin, Shuowen; Magdis, Georgios E.; Daddi, Emanuele; Weaver, John R.; Gobat, Raphael; Kokorev, Vasily; Valentino, Francesco; Finoguenov, Alexis; Shuntov, Marko; Gómez-Guijarro, Carlos; Coogan, Rosemary; Greve, Thomas R.; Toft, Sune; Blaquez Sese, David "A galaxy group candidate at  $z \approx 3.7$  in the COSMOS field," *Astronomy and Astrophysics*, 665: L7, 2022.
- Simonte, M.; Andernach, H.; Brüggén, M.; Schwarz, D. J.; Prandoni, I.; Willis, A. G. "Giant radio galaxies in the LOW-Frequency ARray Two-metre Sky Survey Boötes deep field," *Monthly Notices of the Royal Astronomical Society*, 515: 2032, 2022.
- Simpson, Anna M.; Brown, Michael E.; Schemel, Madeline J.; Butler, Bryan J. "An ALMA Search for High-albedo Objects Among the Midsized Jupiter Trojan Population," *The Astronomical Journal*, 164: 23, 2022.
- Sinha, Akriti; Basu, Aritra; Datta, Abhirup; Chakraborty, Arnab "Deep uGMRT observations of the ELAIS-North 1 field: statistical properties of radio-infrared relations up to  $z = 2$ ," *Monthly Notices of the Royal Astronomical Society*, 514: 4343, 2022.
- Sinigaglia, Francesco; Rodighiero, Giulia; Elson, Ed; Vaccari, Mattia; Maddox, Natasha; Frank, Bradley S.; Jarvis, Matt J.; Oosterloo, Tom; Davé, Romeel; Salvato, Mara; Baes, Maarten; Bellstedt, Sabine; Bisigello, Laura; Collier, Jordan D.; Cook, Robin H. W.; Davies, Luke J. M.; Delhaize, Jacinta; Driver, Simon P.; Foster, Caroline; Kurapati, Sushma; Lagos, Claudia Del P.; Lidman, Christopher; Mancera Piña, Pavel E.; Meyer,



- Martin J.; Mogotsi, K. Moses; Pan, Hengxing; Ponomareva, Anastasia A.; Prandoni, Isabella; Rajohnson, Sambatriniaina H. A.; Robotham, Aaron S. G.; Santos, Mario G.; Sekhar, Srikrishna; Spekkens, Kristine; Thorne, Jessica E.; Van Der Hulst, Jan M.; Wong, O. Ivy "MIGHTEE-HI: Evolution of HI Scaling Relations of Star-forming Galaxies at  $z < 0.5$ ," *The Astrophysical Journal*, 935: L13, 2022.
- Sita, Madelyn L.; Changala, P. Bryan; Xue, Ci; Burkhardt, Andrew M.; Shingledecker, Christopher N.; Kelvin Lee, Kin Long; Loomis, Ryan A.; Momjian, Emmanuel; Siebert, Mark A.; Gupta, Divita; Herbst, Eric; Remijan, Anthony J.; McCarthy, Michael C.; Cooke, Ilsa R.; Mcguire, Brett A. "Discovery of Interstellar 2-Cyanoindene (2-C9H7CN) in GOTHAM Observations of TMC-1," *The Astrophysical Journal*, 938: L12, 2022.
- Slob, M. M.; Callingham, J. R.; Röttgering, H. J. A.; Williams, W. L.; Duncan, K. J.; De Gasperin, F.; Hardcastle, M. J.; Miley, G. K. "Extragalactic peaked-spectrum radio sources at low frequencies are young radio galaxies," *Astronomy and Astrophysics*, 668: A186, 2022.
- Smircina, Adam; Smith, John-David T.; French, K. Decker; Bell, Eric F.; Dale, Daniel A.; Medling, Anne M.; Nyland, Kristina; Privon, George C.; Rowlands, Kate; Walter, Fabian; Zabludoff, Ann I. "After The Fall: Resolving the Molecular Gas in Post-starburst Galaxies," *The Astrophysical Journal*, 929: 154, 2022.
- Smirnova, K.; Wiebe, D. "Molecular and Atomic Gas in Star-forming Complexes: NGC 5194, NGC 5457, NGC 628, and NGC 6946," *Astronomy Reports*, 66: 330, 2022.
- Smirnov-Pinchukov, Grigori V.; Moór, Attila; Semenov, Dmitry A.; Abrahám, Péter; Henning, Thomas; Kóspál, Ágnes; Hughes, A. Meredith; Di Folco, Emmanuel "Lack of other molecules in CO-rich debris discs: is it primordial or secondary gas?," *Monthly Notices of the Royal Astronomical Society*, 510: 1148, 2022.
- Smith, D. J. B.; Krause, M. G.; Hardcastle, M. J.; Drake, A. B. "Relic jet activity in 'Hanny's Voorwerp' revealed by the LOFAR two metre sky survey," *Monthly Notices of the Royal Astronomical Society*, 514: 3879, 2022.
- Smith, E.; Lynch, Ryan S.; Pisano, D. J. "Simulating Spectral Kurtosis Mitigation against Realistic Radio Frequency Interference Signals," *The Astronomical Journal*, 164: 123, 2022.
- Sobolewska, Małgosia; Migliori, Giulia; Ostorero, Luisa; Siemiginowska, Aneta; Stawarz, Łukasz; Guainazzi, Matteo; Hardcastle, Martin J. "The Origin of High-energy Emission in the Young Radio Source PKS 1718-649," *The Astrophysical Journal*, 941: 52, 2022.
- Soker, Noam; Bublitz, Jesse; Kastner, Joel H. "A Twin-jet Structure Rather than Jet Rotation in the Young Stellar Object OMC 2/FIR 6b," *The Astrophysical Journal*, 928: 159, 2022.
- Sokolovsky, Kirill V.; Li, Kwan-Lok; De Oliveira, Raimundo Lopes; Ness, Jan-Uwe; Mukai, Koji; Chomiuk, Laura; Aydi, Elias; Steinberg, Elad; Vurm, Indrek; Metzger, Brian D.; Babul, Aliya-Nur; Kawash, Adam; Linford, Justin D.; Nelson, Thomas; Page, Kim L.; Rupen, Michael P.; Sokoloski, Jennifer L.; Strader, Jay; Kilkenny, David "The first nova eruption in a novalike variable: YZ Ret as seen in X-rays and  $\gamma$ -rays," *Monthly Notices of the Royal Astronomical Society*, 514: pp.2239-2258, 2022.
- Sokolovsky, Kirill V.; Strader, Jay; Swihart, Samuel J.; Aydi, Elias; Bahramian, Arash; Chomiuk, Laura; Heinke, Craig O.; Hughes, Allison K.; Li, Kwan-Lok; De Oliveira, Raimundo Lopes; Miller-Jones, James C. A.; Mukai, Koji; Sand, David J.; Shishkovsky, Laura; Tremou, Evangelia; Voggel, Karina "1RXH J082623.6-505741: A New Long-period Cataclysmic Variable with an Evolved Donor and a Low Mass-transfer Rate," *The Astrophysical Journal*, 934: 142, 2022.
- Somalwar, Jean J.; Ravi, Vikram; Dong, Dillon; Graham, Matthew; Hallinan, Gregg; Law, Casey; Lu, Wenbin; Myers, Steven T. "The Nascent Milliquasar VT J154843.06+220812.6: Tidal Disruption Event or Extreme Accretion State Change?," *The Astrophysical Journal*, 929: 184, 2022.
- Sommovigo, L.; Ferrara, A.; Carniani, S.; Pallottini, A.; Dayal, P.; Pizzati, E.; Ginolfi, M.; Markov, V.; Faisst, A. "A new look at the infrared properties of  $z < 5$  galaxies," *Monthly Notices of the Royal Astronomical Society*, 517: 5930, 2022.
- Song, Y.; Linden, S. T.; Evans, A. S.; Barcos-Muñoz, L.; Murphy, E. J.; Momjian, E.; Díaz-Santos, T.; Larson, K. L.; Privon, G. C.; Huang, X.; Armus, L.; Mazzarella, J. M.; U, V.; Inami, H.; Charmandaris, V.; Ricci, C.; Emig, K. L.; Mckinney, J.; Yoon, I.; Kunneriath, D.; Lai, T. S.-Y.; Rodas-Quito, E. E.; Saravia, A.; Gao, T.; Meynardie, W.; Sanders, D. B. "Characterizing Compact 15-33 GHz Radio Continuum Sources in Local U/LIRGs," *The Astrophysical Journal*, 940: 52, 2022.
- Sotnikova, Yu V.; Wu, Zhongzu; Mufakharov, T. V.; Mikhailov, A. G.; Mingaliev, M. G.; Erkenov, A. K.; Semenova, T. A.; Bursov, N. N.; Udovitskiy, R. Y.; Stolyarov, V. A.; Tsybulev, P. G.; Chen, Y. J.; Zhang, J. S.; Shen, Z.; Jiang, D. R. "Radio continuum properties of OH megamaser galaxies," *Monthly Notices of the Royal Astronomical Society*, 510: 2495, 2022.
- Speedie, Jessica; Dong, Ruobing "Testing Velocity Kinks as a Planet Detection Method: Do Velocity Kinks in Surface Gas Emission Trace Planetary Spiral Wakes in the Midplane Continuum?," *The Astrophysical Journal*, 940: L43, 2022.
- Spencer, Ralph E.; Garrett, Michael; Bray, Justin D.; Green, David A. "Major and minor flares on Cygnus X-3 revisited," *Monthly Notices of the Royal Astronomical Society*, 512: 2618, 2022.
- Spilker, Justin S.; Hayward, Christopher C.; Marrone, Daniel P.; Aravena, Manuel; Béthermin, Matthieu; Burgoyne, James; Chapman, Scott C.; Greve, Thomas R.; Gururajan, Gayathri; Hezaveh, Yashar D.; Hill, Ryley; Litke, Katrina C.; Lovell, Christopher C.; Malkan, Matthew A.; Murphy, Eric J.; Narayanan, Desika; Phadke, Kedar A.; Reuter, Cassie; Stark, Antony A.; Sulzenauer, Nikolaus; Vieira, Joaquin D.; Vizgan, David; Weiß, Axel "Chaotic and Clumpy Galaxy Formation in an Extremely Massive Reionization-era Halo," *The Astrophysical Journal*, 929: L3, 2022.
- Spilker, Justin S.; Suess, Katherine A.; Setton, David J.; Bezanson, Rachel; Feldmann, Robert; Greene, Jenny E.; Kriek, Mariska; Lower, Sidney; Narayanan, Desika; Verrico, Margaret "Star Formation Suppression by Tidal Removal of Cold Molecular Gas from an Intermediate-redshift Massive Post-starburst Galaxy," *The Astrophysical Journal*, 936: L11, 2022.
- Srianand, Raghunathan; Gupta, Neeraj; Petitjean, Patrick; Momjian, Emmanuel; Balashev, Sergei A.; Combes, Françoise; Chen, Hsiao-Wen; Krogager, Jens-Kristian; Noterdaeme, Pasquier; Rahmani, Hadi; Baker, Andrew J.; Emig, Kimberly L.; Józsa, Gyula I. G.; Kloeckner, Hans-Rainer; Moodley, Kavilan "Emergence of a new H I 21-cm absorption component at  $z \approx 1.1726$  towards the  $\gamma$ -ray blazar PKS 2355-106," *Monthly Notices of the Royal Astronomical Society*, 516: 1339, 2022.
- Srinivasaragavan, G. P.; Sfaradi, I.; Jencson, J.; De, K.; Horesch, A.; Kasliwal, M. M.; Tinyanont, S.; Hankins, M.; Schulze, S.; Ashley, M. C. B.; Graham, M. J.; Karambelkar, V.; Lau, R.; Mahabal, A. A.; Moore, A. M.; Ofek, E. O.; Sharma, Y.; Sollerman, J.; Soon, J.; Soria, R.; Travouillon, T.; Walters, R. "PGIR 20eid (SN 2020qmp): A Type IIP Supernova at 15.6 Mpc discovered by the Palomar Gattini-IR survey," *Astronomy and Astrophysics*, 660: A138, 2022.
- Stacey, H. R.; Arrigoni Battaia, F. "Luck of the Irish? A companion of the Cloverleaf connected by a bridge of molecular gas," *Monthly Notices of the Royal Astronomical Society*, 517: L11, 2022.
- Stacey, H. R.; Costa, T.; Mckean, J. P.; Sharon, C. E.; Calistro Rivera, G.; Glikman, E.; Van Der Werf, P. P. "Red quasars blow out molecular gas from galaxies during the peak of cosmic star formation," *Monthly Notices of the Royal Astronomical Society*, 517: 3377, 2022.
- Stapper, L. M.; Hogerheijde, M. R.; Van Dishoeck, E. F.; Mentel, R. "The mass and size of Herbig disks as seen by ALMA," *Astronomy and Astrophysics*, 658: A112, 2022.
- Stinebring, Dan R.; Rickett, Barney J.; Minter, Anthony H.; Hill, Alex S.; Jussila, Adam P.; Mathis, Lele; Mclaughlin, Maura A.; Ocker, Stella Koch; Ransom, Scott M. "A Scintillation Arc Survey of 22 Pulsars with Low to Moderate Dispersion Measures," *The Astrophysical Journal*, 941: 34, 2022.
- Storer, Dara; Dillon, Joshua S.; Jacobs, Daniel C.; Morales, Miguel F.; Hazelton, Bryna J.; Ewall-Wice, Aaron; Abdurashidova, Zara; Aguirre,

## APPENDIX A: PUBLICATIONS

- James E.; Alexander, Paul; Ali, Zaki S.; Balfour, Yanga; Beardsley, Adam P.; Bernardi, Gianni; Billings, Tashalee S.; Bowman, Judd D.; Bradley, Richard F.; Bull, Philip; Burba, Jacob; Carey, Steven; Carilli, Chris L.; Cheng, Carina; Deboer, David R.; De Lera Acedo, Eloy; Dexter, Matt; Dynes, Scott; Ely, John; Fagnoni, Nicolas; Fritz, Randall; Furlanetto, Steven R.; Gale-Sides, Kingsley; Glendenning, Brian; Gorthi, Deepthi; Greig, Bradley; Grobbelaar, Jasper; Halday, Ziyaad; Hewitt, Jacqueline N.; Hickish, Jack; Huang, Tian; Josaitis, Alec; Julius, Austin; Kariseb, Maccalvin; Kern, Nicholas S.; Kerrigan, Joshua; Kittiwisit, Piyanat; Kohn, Saul A.; Kolopanis, Matthew; Lanman, Adam; La Plante, Paul; Liu, Adrian; Louts, Anita; Macmahon, David; Malan, Lourence; Malgas, Cresshim; Martinot, Zachary E.; Mesinger, Andrei; Molewa, Mathakane; Mosiane, Tshogofalang; Murray, Steven G.; Neben, Abraham R.; Nikolic, Bojan; Nunhokee, Chuneeta Devi; Parsons, Aaron R.; Pascua, Robert; Patra, Nipanjana; Pieterse, Samantha; Pober, Jonathan C.; Razavi-Ghods, Nima; Riley, Daniel; Robnett, James; Rosie, Kathryn; Santos, Mario G.; Sims, Peter; Singh, Saurabh; Smith, Craig; Tan, Jianrong; Thyagarajan, Nithyanandan; Williams, Peter K. G.; Zheng, Haoxuan "Automated Detection of Antenna Malfunctions in Large-N Interferometers: A Case Study With the Hydrogen Epoch of Reionization Array," *Radio Science*, 57: e07376, 2022.
- Stuardi, C.; Bonafede, A.; Rajpurohit, K.; Brüggem, M.; De Gasperin, F.; Hoang, D.; Van Weeren, R. J.; Vazza, F. "Using the polarization properties of double radio relics to probe the turbulent compression scenario," *Astronomy and Astrophysics*, 666: A8, 2022.
- Sturm, J. A.; McClure, M. K.; Harsono, D.; Facchini, S.; Long, F.; Kama, M.; Bergin, E. A.; Van Dishoeck, E. F. "Tracing pebble drift and trapping using radial carbon depletion profiles in protoplanetary disks," *Astronomy and Astrophysics*, 660: A126, 2022.
- Su, Yung-Chau; Lin, Lihwai; Pan, Hsi-An; López Cobá, Carlos; Hsieh, Bau-Ching; Sánchez, Sebastián F.; Thorp, Mallory D.; Bureau, Martin; Ellison, Sara L. "The ALMaQUEST Survey. VIII. What Causes the Discrepancy in the Velocity between the CO and H $\alpha$  Rotation Curves in Galaxies?," *The Astrophysical Journal*, 934: 173, 2022.
- Sugahara, Yuma; Inoue, Akio K.; Fudamoto, Yoshinobu; Hashimoto, Takuya; Harikane, Yuichi; Yamanaka, Satoshi "Bridging Optical and Far-infrared Emission-line Diagrams of Galaxies from Local to the Epoch of Reionization: Characteristic High [O III] 88  $\mu$ m/SFR at  $z > 6$ ," *The Astrophysical Journal*, 935: 119, 2022.
- Sullivan, Devin; Wilner, David J.; Matrà, Luca; Wyatt, Mark C.; Andrews, Sean M.; Macgregor, Meredith A.; Matthews, Brenda "An ALMA 1.3 millimeter Search for Debris Disks around Solar-type Stars in the Pleiades," *The Astronomical Journal*, 164: 100, 2022.
- Sumida, Viktor Y. D.; Schutzer, A. De A.; Caproni, A.; Abraham, Z. "The relativistic parsec-scale jets of the blazars TXS 0506+056 and PKS 0502+049 and their possible association with gamma-ray flares and neutrino production," *Monthly Notices of the Royal Astronomical Society*, 509: 1646, 2022.
- Sun, Fengwu; Egami, Eiichi "Do post-starburst galaxies host compact molecular gas reservoirs?," *Monthly Notices of the Royal Astronomical Society*, 517: L126, 2022.
- Sun, Fengwu; Egami, Eiichi; Fujimoto, Seiji; Rawle, Timothy; Bauer, Franz E.; Kohno, Kotaro; Smail, Ian; Pérez-González, Pablo G.; Ao, Yiping; Chapman, Scott C.; Combes, Françoise; Dessauges-Zavadsky, Miroslava; Espada, Daniel; González-López, Jorge; Koekemoer, Anton M.; Kokorev, Vasily; Lee, Minju M.; Morokuma-Matsui, Kana; Muñoz Arancibia, Alejandra M.; Oguri, Masamune; Pelló, Roser; Ueda, Yoshihiro; Uematsu, Ryosuke; Valentino, Francesco; Van Der Werf, Paul; Walth, Gregory L.; Zemcov, Michael; Zitri, Adi "ALMA Lensing Cluster Survey: ALMA-Herschel Joint Study of Lensed Dusty Star-forming Galaxies across  $z = 0.5 - 6$ ," *The Astrophysical Journal*, 932: 77, 2022.
- Sun, Jiayi; Leroy, Adam K.; Rosolowsky, Erik; Hughes, Annie; Schinnerer, Eva; Schrubba, Andreas; Koch, Eric W.; Blanc, Guillermo A.; Chiang, I.-Da; Groves, Brent; Liu, Daizhong; Meidt, Sharon; Pan, Hsi-An; Pety, Jérôme; Querejeta, Miguel; Saito, Toshiki; Sandstrom, Karin; Sardone, Amy; Usero, Antonio; Utomo, Dyas; Williams, Thomas G.; Barnes, Ashley T.; Benincasa, Samantha M.; Bigiel, Frank; Bolatto, Alberto D.; Boquien, Médéric; Chevance, Mélanie; Dale, Daniel A.; Deger, Sinan; Emsellem, Eric; Glover, Simon C. O.; Grasha, Kathryn; Henshaw, Jonathan D.; Klessen, Ralf S.; Kreckel, Kathryn; Kruijssen, J. M. Diederik; Ostriker, Eve C.; Thilker, David A. "Molecular Cloud Populations in the Context of Their Host Galaxy Environments: A Multiwavelength Perspective," *The Astronomical Journal*, 164: 43, 2022.
- Sun, Yan; Zhang, Bo; Reid, Mark J.; Xu, Shuangjing; Wen, Shiming; Zhang, Jingdong; Zheng, Xingwu "A Very Long Baseline Array Trigonometric Parallax for RR Aql and the Mira Period-Luminosity Relation," *The Astrophysical Journal*, 931: 74, 2022.
- Supan, L.; Fischetto, G.; Castelletti, G. "Supernova remnant G46.8-0.3: A new case of interaction with molecular material," *Astronomy and Astrophysics*, 664: A89, 2022.
- Suresh, Akshay; Cordes, James M.; Chatterjee, Shami; Gajjar, Vishal; Perez, Karen I.; Siemion, Andrew P. V.; Lebofsky, Matt; Macmahon, David H. E.; Ng, Cherry "4-8 GHz Fourier-domain Searches for Galactic Center Pulsars," *The Astrophysical Journal*, 933: 121, 2022.
- Sutter, Jessica; Fadda, Dario "[C II] Map of the Molecular Ring and Arms of the Spiral Galaxy NGC 7331," *The Astrophysical Journal*, 926: 82, 2022.
- Suzuki, Tomoko L.; Glazebrook, Karl; Schreiber, Corentin; Kodama, Tadayuki; Kacprzak, Glenn G.; Leiton, Roger; Nanayakkara, Themiyā; Oesch, Pascal A.; Papovich, Casey; Spitler, Lee; Straatman, Caroline M. S.; Tran, Kim-Vy; Wang, Tao "Low Star Formation Activity and Low Gas Content of Quiescent Galaxies at  $z = 3.5-4.0$  Constrained with ALMA," *The Astrophysical Journal*, 936: 61, 2022.
- Swiggum, Cameren; Tremonti, Christy; Perrotta, Serena; Schaefer, Adam; Hickox, Ryan C.; Coil, Alison L.; Sell, Paul H.; Diamond-Stanic, Aleksandar M.; Krause, Jalyn; Mosby, Gregory "Understanding the Nature of an Unusual Post-starburst Quasar with Exceptionally Strong Ne V Emission," *The Astrophysical Journal*, 929: 79, 2022.
- Swihart, Samuel J.; Strader, Jay; Chomiuk, Laura; Aydi, Elias; Sokolovsky, Kirill V.; Ray, Paul S.; Kerr, Matthew "A New Flaring Black Widow Candidate and Demographics of Black Widow Millisecond Pulsars in the Galactic Field," *The Astrophysical Journal*, 941: 199, 2022.
- Syed, J.; Soler, J. D.; Beuther, H.; Wang, Y.; Suri, S.; Henshaw, J. D.; Rienen, M.; Bialy, S.; Rezaei Kh., S.; Stil, J. M.; Goldsmith, P. F.; Rugel, M. R.; Glover, S. C. O.; Klessen, R. S.; Kerp, J.; Urquhart, J. S.; Ott, J.; Roy, N.; Schneider, N.; Smith, R. J.; Longmore, S. N.; Linz, H. "The 'Maggie' filament: Physical properties of a giant atomic cloud," *Astronomy and Astrophysics*, 657: A1, 2022.
- Taank, Mukesh; Marchal, Antoine; Martin, Peter G.; Vujeva, Luka "Mapping the Thermal Condensation of Diffuse H I in the North Celestial Pole Loop," *The Astrophysical Journal*, 937: 81, 2022.
- Tabatabaei, F. S.; Cotton, W.; Schinnerer, E.; Beck, R.; Brunthaler, A.; Menten, K. M.; Braine, J.; Corbelli, E.; Kramer, C.; Beckman, J. E.; Knapen, J. H.; Paladino, R.; Koch, E.; Camps Fariña, A. "Cloud-scale radio surveys of star formation and feedback in Triangulum Galaxy M 33: VLA observations," *Monthly Notices of the Royal Astronomical Society*, 517: 2990, 2022.
- Tadaki, Ken-Ichi; Tsujita, Akiyoshi; Tamura, Yoichi; Kohno, Kotaro; Hatsukade, Bunyo; Iono, Daisuke; Lee, Minju M.; Matsuda, Yuichi; Michiyama, Tomonari; Nagao, Tohru; Nakanishi, Kouichiro; Nishimura, Yuri; Saito, Toshiki; Umehata, Hideki; Zavala, Jorge "Detection of nitrogen and oxygen in a galaxy at the end of reionization," *Publications of the Astronomical Society of Japan*, 74: L9, 2022.
- Tafaya, Daniel; Toalá, Jesús A.; Unnikrishnan, Ramlal; Vlemmings, Wouter H. T.; Guerrero, Martín A.; Kimeswenger, Stefan; Van Hoof, Peter A. M.; Zapata, Luis A.; Treviño-Morales, Sandra P.; Rodríguez-González, Janis B. "First Images of the Molecular Gas around a Born-again Star Revealed by ALMA," *The Astrophysical Journal*, 925: L4, 2022.
- Takeda, L.; Diaz, M.; Campbell, R. D.; Lyke, J. E.; Lawrence, S. S.; Linford, J. D.; Sokolovsky, K. V. "Optical and NIR data and modelling of nova V5668 Sgr," *Monthly Notices of the Royal Astronomical Society*, 511:

- 1591, 2022.
- Tamhane, Prathamesh D.; Mcnamara, Brian R.; Russell, Helen R.; Edge, Alastair C.; Fabian, Andrew C.; Nulsen, Paul E. J.; Babyk, Iurii V. "Molecular flows in contemporary active galaxies and the efficacy of radio-mechanical feedback," *Monthly Notices of the Royal Astronomical Society*, 516: 861, 2022.
- Tang, Mengyao; Palau, Aina; Zapata, Luis A.; Qin, Sheng-Li "W51 North: A protocluster emerging out of a thermally inhibited fragmenting cloud," *Astronomy and Astrophysics*, 657: A30, 2022.
- Taniguchi, Kotomi; Tanaka, Kei E. I.; Zhang, Yichen; Fedriani, Rubén; Tan, Jonathan C.; Takakuwa, Shigehisa; Nakamura, Fumitaka; Saito, Masao; Majumdar, Liton; Herbst, Eric "Vibrationally Excited Lines of HC3N Associated with the Molecular Disk around the G24.78+0.08 A1 Hypercompact H II Region," *The Astrophysical Journal*, 931: 99, 2022.
- Taylor, Rhys; Köppen, Joachim; Jáchym, Pavel; Minchin, Robert; Palouš, Jan; Rosenberg, Jessica L.; Schneider, Stephen; Wunsch, Richard; Deshev, Boris "The Arecibo Galaxy Environment Survey. XII. Optically Dark H I Clouds in the Leo I Group," *The Astronomical Journal*, 164: 233, 2022.
- Teague, Richard; Bae, Jaehan; Andrews, Sean M.; Benisty, Myriam; Bergin, Edwin A.; Facchini, Stefano; Huang, Jane; Longarini, Cristiano; Wilner, David "Mapping the Complex Kinematic Substructure in the TW Hya Disk," *The Astrophysical Journal*, 936: 163, 2022.
- Teague, Richard; Bae, Jaehan; Benisty, Myriam; Andrews, Sean M.; Facchini, Stefano; Huang, Jane; Wilner, David "Gas and Dust Shadows in the TW Hydrae Disk," *The Astrophysical Journal*, 930: 144, 2022.
- Temi, P.; Gaspari, M.; Brighenti, F.; Werner, N.; Grossova, R.; Gitti, M.; Sun, M.; Amblard, A.; Simionescu, A. "Probing Multiphase Gas in Local Massive Elliptical Galaxies via Multiwavelength Observations," *The Astrophysical Journal*, 928: 150, 2022.
- Teng, Yu-Hsuan; Sandstrom, Karin M.; Sun, Jiayi; Leroy, Adam K.; Johnson, L. Clifton; Bolatto, Alberto D.; Kruijssen, J. M. Diederik; Schrubba, Andreas; Usero, Antonio; Barnes, Ashley T.; Bigiel, Frank; Blanc, Guillermo A.; Groves, Brent; Israel, Frank P.; Liu, Daizhong; Rosolowsky, Erik; Schinnerer, Eva; Smith, J. D.; Walter, Fabian "Molecular Gas Properties and CO-to-H<sub>2</sub> Conversion Factors in the Central Kiloparsec of NGC 3351," *The Astrophysical Journal*, 925: 72, 2022.
- Terreran, G.; Jacobson-Galán, W. V.; Groh, J. H.; Margutti, R.; Coppejans, D. L.; Dimitriadis, G.; Kilpatrick, C. D.; Matthews, D. J.; Siebert, M. R.; Angus, C. R.; Brink, T. G.; Filippenko, A. V.; Foley, R. J.; Jones, D. O.; Tinyanont, S.; Gall, C.; Pfister, H.; Zenati, Y.; Ansari, Z.; Auchettl, K.; El-Badry, K.; Magnier, E. A.; Zheng, W. "The Early Phases of Supernova 2020pni: Shock Ionization of the Nitrogen-enriched Circumstellar Material," *The Astrophysical Journal*, 926: 20, 2022.
- Thelen, Alexander E.; Nixon, Conor A.; Cosentino, Richard G.; Cordiner, Martin A.; Teanby, Nicholas A.; Newman, Claire E.; Irwin, Patrick G. J.; Charnley, Steven B. "Variability in Titan's Mesospheric HCN and Temperature Structure as Observed by ALMA," *The Planetary Science Journal*, 3: 146, 2022.
- Thieme, Travis J.; Lai, Shih-Ping; Lin, Sheng-Jun; Cheong, Pou-leng; Lee, Chin-Fei; Yen, Hsi-Wei; Li, Zhi-Yun; Lam, Ka Ho; Zhao, Bo "Accretion Flows or Outflow Cavities? Uncovering the Gas Dynamics around Lupus 3-MMS," *The Astrophysical Journal*, 925: 32, 2022.
- Thomas, Benjamin P.; Wheeler, J. Craig; Dwarkadas, Vikram V.; Stockdale, Christopher; Vinkó, Jozsef; Pooley, David; Xu, Yerong; Zeimann, Greg; Macqueen, Phillip "Seven Years of SN 2014C: A Multiwavelength Synthesis of an Extraordinary Supernova," *The Astrophysical Journal*, 930: 57, 2022.
- Thorp, Mallory D.; Ellison, Sara L.; Pan, Hsi-An; Lin, Lihwai; Patton, David R.; Bluck, Asa F. L.; Walters, Dan; Scudder, Jillian M. "The ALMAQUEST Survey X: what powers merger induced star formation?," *Monthly Notices of the Royal Astronomical Society*, 516: 1462, 2022.
- Thyagarajan, Nithyanandan; Carilli, Chris L. "A Geometric View of Closure Phases in Interferometry," *Publications of the Astronomical Society of Australia*, 39: e014, 2022.
- Thyagarajan, Nithyanandan; Nityananda, Rajaram; Samuel, Joseph "Invariants in copolar interferometry: An Abelian gauge theory," *Physical Review D*, 105: 043019, 2022.
- Timmerman, R.; Van Weeren, R. J.; Botteon, A.; Röttgering, H. J. A.; Mcnamara, B. R.; Sweijen, F.; Birzan, L.; Morabito, L. K. "Measuring cavity powers of active galactic nuclei in clusters using a hybrid X-ray-radio method. A new window on feedback opened by subarcsecond LOFAR-VLBI observations," *Astronomy and Astrophysics*, 668: A65, 2022.
- Timmerman, R.; Van Weeren, R. J.; Callingham, J. R.; Cotton, W. D.; Perley, R.; Morabito, L. K.; Gizani, N. A. B.; Bridle, A. H.; O'Dea, C. P.; Baum, S. A.; Tremblay, G. R.; Kharb, P.; Kassim, N. E.; Röttgering, H. J. A.; Botteon, A.; Sweijen, F.; Tasse, C.; Brüggem, M.; Moldon, J.; Shimwell, T.; Brunetti, G. "Origin of the ring structures in Hercules A. Sub-arcsecond 144 MHz to 7 GHz observations," *Astronomy and Astrophysics*, 658: A5, 2022.
- Titov, Oleg; Frey, Sándor; Melnikov, Alexey; Lambert, Sébastien; Shu, Fengchun; Xia, Bo; González, Javier; Tercero, Belén; Gulayev, Sergey; Weston, Stuart; Natusch, Tim "Unprecedented change in the position of four radio sources," *Monthly Notices of the Royal Astronomical Society*, 512: 874, 2022.
- Tiwari, Juhí; Singh, Kulinder Pal "The complex intracluster medium of Abell 1569 and its interaction with central radio galaxies," *Monthly Notices of the Royal Astronomical Society*, 509: 3321, 2022.
- Tiwari, Prabhakar; Jain, Pankaj "A mechanism to explain galaxy alignment over a range of scales," *Monthly Notices of the Royal Astronomical Society*, 513: 604, 2022.
- Tobin, John J.; Cox, Erin G.; Looney, Leslie W. "A 16 au Binary in the Class 0 Protostar L1157 MMS," *The Astrophysical Journal*, 928: 61, 2022.
- Tobin, John J.; Offner, Stella S. R.; Kratter, Kaitlin M.; Megeath, S. Thomas; Sheehan, Patrick D.; Looney, Leslie W.; Diaz-Rodriguez, Ana Karla; Osorio, Mayra; Anglada, Guillem; Sadavoy, Sarah I.; Furlan, Elise; Segura-Cox, Dominique; Karnath, Nicole; Van'T Hoff, Merel L. R.; Van Dishoeck, Ewine F.; Li, Zhi-Yun; Sharma, Rajeeb; Stutz, Amelia M.; Tychoniec, Łukasz "The VLA/ALMA Nascent Disk And Multiplicity (VANDAM) Survey of Orion Protostars. V. A Characterization of Protostellar Multiplicity," *The Astrophysical Journal*, 925: 39, 2022.
- Tokuda, Kazuki; Minami, Taisei; Fukui, Yasuo; Inoue, Tsuyoshi; Nishioka, Takeru; Tsuge, Kizetsu; Zahorecz, Sarolta; Sano, Hidetoshi; Konishi, Ayu; Rosie Chen, C.-H.; Sewito, Marta; Madden, Suzanne C.; Nayak, Omnarayani; Saigo, Kazuya; Nishimura, Atsushi; Tanaka, Kei E. I.; Sawada, Tsuyoshi; Indebetouw, Remy; Tachihara, Kengo; Kawamura, Akiko; Onishi, Toshikazu "An ALMA Study of the Massive Molecular Clump N159W-North in the Large Magellanic Cloud: A Possible Gas Flow Penetrating One of the Most Massive Protocluster Systems in the Local Group," *The Astrophysical Journal*, 933: 20, 2022.
- Tokuda, Kazuki; Zahorecz, Sarolta; Kunitoshi, Yuri; Higashino, Kosuke; Tanaka, Kei E. I.; Konishi, Ayu; Suzuki, Taisei; Kitano, Naoya; Harada, Naoto; Shimonishi, Takashi; Neelamkodan, Naslim; Fukui, Yasuo; Kawamura, Akiko; Onishi, Toshikazu; Machida, Masahiro N. "The First Detection of a Protostellar CO Outflow in the Small Magellanic Cloud with ALMA," *The Astrophysical Journal*, 936: L6, 2022.
- Tokuoka, Tsuyoshi; Inoue, Akio K.; Hashimoto, Takuya; Ellis, Richard S.; Laporte, Nicolas; Sugahara, Yuma; Matsuo, Hiroshi; Tamura, Yoichi; Fudamoto, Yoshinobu; Moriwaki, Kana; Roberts-Borsani, Guido; Shimizu, Ikkoh; Yamanaka, Satoshi; Yoshida, Naoki; Zackrisson, Erik; Zheng, Wei "Possible Systematic Rotation in the Mature Stellar Population of a  $z = 9.1$  Galaxy," *The Astrophysical Journal*, 933: L19, 2022.
- Topping, Michael W.; Stark, Daniel P.; Endsley, Ryan; Bouwens, Rychard J.; Schouws, Sander; Smit, Renske; Stefanon, Mauro; Inami, Hanae; Bowler, Rebecca A. A.; Oesch, Pascal; Gonzalez, Valentino; Dayal, Pratika; Da Cunha, Elisabete; Algera, Hidido; Van Der Werf, Paul; Pallottini, Andrea; Barrufet, Laia; Schneider, Raffaella; De Looze, Ilse; Sommovigo, Laura; Whittler, Lily; Graziani, Luca; Fudamoto, Yoshinobu; Ferrara, Andrea "The ALMA REBELS Survey: specific star formation rates in the reionization era," *Monthly Notices of the Royal Astronomical Society*, 516: 1462, 2022.

## APPENDIX A: PUBLICATIONS

- Society, 516: 975, 2022.
- Tozzi, P.; Gilli, R.; Liu, A.; Borgani, S.; Lepore, M.; Di Mascolo, L.; Saro, A.; Pentericci, L.; Carilli, C.; Miley, G.; Mroczkowski, T.; Pannella, M.; Rasia, E.; Rosati, P.; Anderson, C. S.; Calabrò, A.; Churazov, E.; Dannerbauer, H.; Feruglio, C.; Fiore, F.; Gobat, R.; Jin, S.; Nonino, M.; Norman, C.; Röttgering, H. J. A. "The 700 ks Chandra Spiderweb Field. II. Evidence for inverse-Compton and thermal diffuse emission in the Spiderweb galaxy," *Astronomy and Astrophysics*, 667: A134, 2022.
- Tozzi, P.; Pentericci, L.; Gilli, R.; Pannella, M.; Fiore, F.; Miley, G.; Nonino, M.; Röttgering, H. J. A.; Strazzullo, V.; Anderson, C. S.; Borgani, S.; Calabrò, A.; Carilli, C.; Dannerbauer, H.; Di Mascolo, L.; Feruglio, C.; Gobat, R.; Jin, S.; Liu, A.; Mroczkowski, T.; Norman, C.; Rasia, E.; Rosati, P.; Saro, A. "The 700 ks Chandra Spiderweb Field. I. Evidence for widespread nuclear activity in the protocluster," *Astronomy and Astrophysics*, 662: A54, 2022.
- Tripodì, R.; Feruglio, C.; Fiore, F.; Bischetti, M.; D'Odorico, V.; Carniani, S.; Cristiani, S.; Gallerani, S.; Maiolino, R.; Marconi, A.; Pallottini, A.; Piconcelli, E.; Vallini, L.; Zana, T. "Black hole and host galaxy growth in an isolated  $z \approx 6$  QSO observed with ALMA," *Astronomy and Astrophysics*, 665: A107, 2022.
- Tristram, Konrad R. W.; Impellizzeri, C. M. Violette; Zhang, Zhi-Yu; Villard, Eric; Henkel, Christian; Viti, Serena; Burtscher, Leonard; Combes, Françoise; García-Burillo, Santiago; Martín, Sergio; Meisenheimer, Klaus; Van Der Werf, Paul P. "ALMA imaging of the cold molecular and dusty disk in the type 2 active nucleus of the Circinus galaxy," *Astronomy and Astrophysics*, 664: A142, 2022.
- Tsuboi, Masato; Tsutsumi, Takahiro; Miyazaki, Atsushi; Miyawaki, Ryosuke; Miyoshi, Makoto "ALMA astrometry of the objects within 0.5 pc of Sagittarius A\*," *Publications of the Astronomical Society of Japan*, 74: 738, 2022.
- Tsujita, Akiyoshi; Tadaki, Ken-Ichi; Kohno, Kotaro; Hatsukade, Bunyo; Egusa, Fumi; Tamura, Yoichi; Nishimura, Yuri; Zavala, Jorge; Saito, Toshiaki; Umehata, Hideki; Lee, Minju M. "Central concentration of warm and dense molecular gas in a strongly lensed submillimeter galaxy at  $z = 6$ ," *Publications of the Astronomical Society of Japan*, 74: 1429, 2022.
- Tsukagoshi, Takashi; Nomura, Hideko; Muto, Takayuki; Kawabe, Ryohei; Kanagawa, Kazuhiro D.; Okuzumi, Satoshi; Ida, Shigeru; Walsh, Catherine; Millar, Tom J.; Takahashi, Sanemichi Z.; Hashimoto, Jun; Uyama, Taichi; Tamura, Motohide "ALMA High-resolution Multiband Analysis for the Protoplanetary Disk around TW Hya," *The Astrophysical Journal*, 928: 49, 2022.
- Turner, Jordan A.; Dale, Daniel A.; Lilly, James; Boquien, Mederic; Deger, Sinan; Lee, Janice C.; Whitmore, Bradley C.; Anand, Gagandeep S.; Benincasa, Samantha M.; Bigiel, Frank; Blanc, Guillermo A.; Chevance, Mélanie; Emsellem, Eric; Faesi, Christopher M.; Glover, Simon C. O.; Grasha, Kathryn; Hughes, Annie; Klessen, Ralf S.; Kreckel, Kathryn; Kruijssen, J. M. Diederik; Leroy, Adam K.; Pan, Hsi-An; Rosolowsky, Erik; Schruba, Andreas; Williams, Thomas G. "PHANGS: constraining star formation time-scales using the spatial correlations of star clusters and giant molecular clouds," *Monthly Notices of the Royal Astronomical Society*, 516: 4612, 2022.
- Tusay, Nick; Huston, Macy J.; Dedrick, Cayla M.; Kerby, Stephen; Palumbo, Michael L.; Iii; Croft, Steve; Wright, Jason T.; Robertson, Paul; Sheikh, Sofia; Duffy, Laura; Foote, Gregory; Hyde, Andrew; Lafond, Julia; Mullikin, Ella; Parts, Winter; Sandhaus, Phoebe; Smith, Hillary H.; Sneed, Evan L.; Czech, Daniel; Gajjar, Vishal; Breakthrough Listen "A Search for Radio Technosignatures at the Solar Gravitational Lens Targeting Alpha Centauri," *The Astronomical Journal*, 164: 116, 2022.
- U, Vivian; Lai, Thomas; Bianchin, Marina; Remigio, Raymond P.; Armus, Lee; Larson, Kirsten L.; Diaz-Santos, Tanio; Evans, Aaron; Stierwalt, Sabrina; Law, David R.; Malkan, Matthew A.; Linden, Sean; Song, Yiqing; Van Der Werf, Paul P.; Gao, Tianmu; Privon, George C.; Medling, Anne M.; Barcos-Muñoz, Loreto; Hayward, Christopher C.; Inami, Hanae; Rich, Jeff; Aalto, Susanne; Appleton, Philip; Bohn, Thomas; Böker, Torsten; Brown, Michael J. I.; Charmandaris, Vassilis; Finnerty, Luke; Howell, Justin; Iwasawa, Kazushi; Kemper, Francisca; Marshall, Jason; Mazzarella, Joseph M.; Mckinney, Jed; Muller-Sanchez, Francisco; Murphy, Eric J.; Sanders, David; Surace, Jason "GOALS-JWST: Resolving the Circumnuclear Gas Dynamics in NGC 7469 in the Mid-infrared," *The Astrophysical Journal*, 940: L5, 2022.
- Uchiyama, Hisakazu; Yamashita, Takuji; Nagao, Tohru; Ichikawa, Kohei; Toba, Yoshiki; Ishikawa, Shogo; Kubo, Mariko; Kajisawa, Masaru; Kawaguchi, Toshihiro; Kawakatu, Nozomu; Lee, Chien-Hsiu; Noboriguchi, Akatoki "A Wide and Deep Exploration of Radio Galaxies with Subaru HSC (WERGS). VII. Redshift Evolution of Radio Galaxy Environments at  $z = 0.3-1.4$ ," *The Astrophysical Journal*, 934: 68, 2022.
- Uchiyama, Hisakazu; Yamashita, Takuji; Toshikawa, Jun; Kashikawa, Nobunari; Ichikawa, Kohei; Kubo, Mariko; Ito, Kei; Kawakatu, Nozomu; Nagao, Tohru; Toba, Yoshiki; Ono, Yoshiaki; Harikane, Yuichi; Imanishi, Masatoshi; Kajisawa, Masaru; Lee, Chien-Hsiu; Liang, Yongming "A Wide and Deep Exploration of Radio Galaxies with Subaru HSC (WERGS). VI. Distant Filamentary Structures Pointed Out by High- $z$  Radio Galaxies at  $z \approx 4$ ," *The Astrophysical Journal*, 926: 76, 2022.
- Ueda, Junko; Michiyama, Tomonari; Iono, Daisuke; Miyamoto, Yusuke; Saito, Toshiaki "Spatially-resolved relation between [C II] 3P1-3P0 and 12CO (1-0) in Arp 220," *Publications of the Astronomical Society of Japan*, 74: 407, 2022.
- Ueda, Takahiro; Kataoka, Akimasa; Tsukagoshi, Takashi "Massive Compact Dust Disk with a Gap around CW Tau Revealed by ALMA Multiband Observations," *The Astrophysical Journal*, 930: 56, 2022.
- Urquhart, Ryan; McDermott, Lauren I.; Strader, Jay; Seth, Anil C.; Chomiuk, Laura; Neumayer, Nadine; Nguyen, Dieu D.; Tremou, Evangelia "X-Ray and Radio Observations of Central Black Holes in Nearby Low-mass Early-type Galaxies: Preliminary Evidence for Low Eddington Fractions," *The Astrophysical Journal*, 940: 111, 2022.
- Urquhart, S. A.; Bendo, G. J.; Serjeant, S.; Bakx, T.; Hagimoto, M.; Cox, P.; Neri, R.; Lehnert, M.; Sedgwick, C.; Weiner, C.; Dannerbauer, H.; Amvrosiadis, A.; Andreani, P.; Baker, A. J.; Beelen, A.; Berta, S.; Borsato, E.; Buat, V.; Butler, K. M.; Cooray, A.; De Zotti, G.; Dunne, L.; Dye, S.; Eales, S.; Enia, A.; Fan, L.; Gavazzi, R.; González-Nuevo, J.; Harris, A. I.; Herrera, C. N.; Hughes, D.; Ismail, D.; Ivison, R.; Jin, S.; Jones, B.; Kohno, K.; Krips, M.; Lagache, G.; Marchetti, L.; Massardi, M.; Messias, H.; Negrello, M.; Omont, A.; Perez-Fournon, I.; Riechers, D. A.; Scott, D.; Smith, M. W. L.; Stanley, F.; Tamura, Y.; Temi, P.; Vlahakis, C.; Weiß, A.; Van Der Werf, P.; Verma, A.; Yang, C.; Young, A. J. "The bright extragalactic ALMA redshift survey (BEARS) I: redshifts of bright gravitationally lensed galaxies from the Herschel ATLAS," *Monthly Notices of the Royal Astronomical Society*, 511: 3017, 2022.
- Vacca, Valentina; Govoni, Federica; Murgia, Matteo; Perley, Richard A.; Feretti, Luigina; Giovannini, Gabriele; Carretti, Ettore; Gastaldello, Fabio; Cova, Filippo; Marchegiani, Paolo; Battistelli, Elia; Boschin, Walter; Enßlin, Torsten A.; Girardi, Marisa; Loi, Francesca; Radiconi, Federico "Puzzling large-scale polarization in the galaxy cluster Abell 523," *Monthly Notices of the Royal Astronomical Society*, 514: 4969, 2022.
- Vacca, Valentina; Shimwell, Timothy; Perley, Richard A.; Govoni, Federica; Murgia, Matteo; Feretti, Luigina; Giovannini, Gabriele; Loi, Francesca; Carretti, Ettore; Cova, Filippo; Gastaldello, Fabio; Girardi, Marisa; Enßlin, Torsten; Akamatsu, Hiroki; Bonafede, Annalisa; Bonnasieux, Etienne; Boschin, Walter; Botteon, Andrea; Brunetti, Gianfranco; Brügggen, Marcus; Finoguenov, Alexis; Hoang, Duy; Iacobelli, Marco; Orrù, Emanuela; Paladino, Rosita; Röttgering, Huub; Van Weeren, Reinout; Vitello, Fabio; Wittor, Denis "Spectral study of the diffuse synchrotron source in the galaxy cluster Abell 523," *Monthly Notices of the Royal Astronomical Society*, 511: 3389, 2022.
- Vacca, William D.; Sandell, Göran "Multiwavelength Observations of MWC 297: Constraints on Disk Inclination and Mass Outflow," *The Astrophysical Journal*, 941: 189, 2022.
- Valentino, Francesco; Brammer, Gabriel; Fujimoto, Seiji; Heintz, Kasper E.; Weaver, John R.; Strait, Victoria; Gould, Katrina M. L.; Mason, Charlotte;

- Watson, Darach; Laursen, Peter; Toft, Sune "The Archival Discovery of a Strong Ly $\alpha$  and [C II] Emitter at  $z = 7.677$ ," *The Astrophysical Journal*, 929: L9, 2022.
- Van Bommel, Ilse M.; Kettenis, Mark; Small, Des; Janssen, Michael; Moellenbrock, George A.; Petry, Dirk; Goddi, Ciriaco; Linford, Justin D.; Rygl, Kazi L. J.; Liuzzo, Elisabetta; Marcote, Benito; Bayandina, Olga S.; Schweighart, Neal; Verkouter, Marjolein; Keimpema, Aard; Szomoru, Arpad; Van Langevelde, Huib Jan "CASA on the Fringe-Development of VLBI Processing Capabilities for CASA," *Publications of the Astronomical Society of the Pacific*, 134: 114502, 2022.
- Van Den Eijnden, J.; Degenaar, N.; Russell, T. D.; Miller-Jones, J. C. A.; Rouco Escorial, A.; Wijnands, R.; Sivakoff, G. R.; Hernández Santisteban, J. V. "Radio monitoring of transient Be/X-ray binaries and the inflow-outflow coupling of strongly magnetized accreting neutron stars," *Monthly Notices of the Royal Astronomical Society*, 516: 4844, 2022.
- Van Der Vlugt, D.; Hodge, J. A.; Algera, H. S. B.; Smail, I.; Leslie, S. K.; Radcliffe, J. F.; Riechers, D. A.; Röttgering, H. "An Ultra-deep Multiband Very Large Array (VLA) Survey of the Faint Radio Sky (COSMOS-XS): New Constraints on the Cosmic Star Formation History," *The Astrophysical Journal*, 941: 10, 2022.
- Van Gelder, M. L.; Jaspers, J.; Nazari, P.; Ahmadi, A.; Van Dishoeck, E. F.; Beltrán, M. T.; Fuller, G. A.; Sánchez-Monge, Á.; Schilke, P. "Methanol deuteration in high-mass protostars," *Astronomy and Astrophysics*, 667: A136, 2022.
- Van Gelder, M. L.; Nazari, P.; Tabone, B.; Ahmadi, A.; Van Dishoeck, E. F.; Beltrán, M. T.; Fuller, G. A.; Sakai, N.; Sánchez-Monge, Á.; Schilke, P.; Yang, Y.-L.; Zhang, Y. "Importance of source structure on complex organics emission. I. Observations of CH<sub>3</sub>OH from low-mass to high-mass protostars," *Astronomy and Astrophysics*, 662: A67, 2022.
- Van Terwisga, S. E.; Hacar, A.; Van Dishoeck, E. F.; Oonk, R.; Portegies Zwart, S. "Survey of Orion Disks with ALMA (SODA). I. Cloud-level demographics of 873 protoplanetary disks," *Astronomy and Astrophysics*, 661: A53, 2022.
- Vanderhoof, Brittany N.; Faisst, A. L.; Shen, L.; Lemaux, B. C.; Béthermin, M.; Capak, P. L.; Cassata, P.; Le Fèvre, O.; Schaerer, D.; Silverman, J.; Yan, L.; Boquien, M.; Gal, R.; Kartaltepe, J.; Lubin, L. M.; Dessauges-Zavadsky, M.; Fudamoto, Y.; Ginolfi, M.; Hathi, N. P.; Jones, G. C.; Koekemoer, A. M.; Narayanan, D.; Romano, M.; Talia, M.; Vergani, D.; Zamorani, G. "The ALPINE-ALMA [C II] survey: Investigation of 10 galaxies at  $z = 4.5$  with [O II] and [C II] line emission - ISM properties and [O II]-SFR relation," *Monthly Notices of the Royal Astronomical Society*, 511: 1303, 2022.
- Van'T Hoff, Merel L. R.; Harsono, Daniel; Van Gelder, Martijn L.; Hsieh, Tien-Hao; Tobin, John J.; Jensen, Sigurd S.; Hirano, Naomi; Jørgensen, Jes K.; Bergin, Edwin A.; Van Dishoeck, Ewine F. "Imaging the Water Snowline around Protostars with Water and HCO<sup>+</sup> Isotopologues," *The Astrophysical Journal*, 924: 5, 2022.
- Van'T Hoff, Merel L. R.; Leemker, Margot; Tobin, John J.; Harsono, Daniel; Jørgensen, Jes K.; Bergin, Edwin A. "The Young Embedded Disk L1527 IRS: Constraints on the Water Snowline and Cosmic-Ray Ionization Rate from HCO<sup>+</sup> Observations," *The Astrophysical Journal*, 932: 6, 2022.
- Vastel, C.; Alves, F.; Ceccarelli, C.; Bouvier, M.; Jiménez-Serra, I.; Sakai, T.; Caselli, P.; Evans, L.; Fontani, F.; Le Gal, R.; Chandler, C. J.; Svoboda, B.; Maud, L.; Codella, C.; Sakai, N.; López-Sepulcre, A.; Moellenbrock, G.; Aikawa, Y.; Balucani, N.; Bianchi, E.; Busquet, G.; Caux, E.; Charnley, S.; Cuello, N.; De Simone, M.; Dulieu, F.; Durán, A.; Fedele, D.; Feng, S.; Francis, L.; Hama, T.; Hanawa, T.; Herbst, E.; Hirota, T.; Imai, M.; Isella, A.; Johnstone, D.; Lefloch, B.; Loinard, L.; Maureira, M.; Murillo, N. M.; Mercimek, S.; Mori, S.; Menard, F.; Miotello, A.; Nakatani, R.; Nomura, H.; Oba, Y.; Ohashi, S.; Okoda, Y.; Ospina-Zamudio, J.; Oya, Y.; Pineda, J. E.; Podio, L.; Rimola, A.; Cox, D. Segura; Shirley, Y.; Testi, L.; Viti, S.; Watanabe, N.; Watanabe, Y.; Witzel, A.; Xue, C.; Zhang, Y.; Zhao, B.; Yamamoto, S. "FAUST. V. Hot methanol in the [BHB2007] 11 protobinary system; hot corino versus shock origin," *Astronomy and Astrophysics*, 664: A171, 2022.
- Vávra, K.; Kolesníková, L.; Belloche, A.; Garrod, R. T.; Koucký, J.; Uhlířková, T.; Luková, K.; Guillemin, J.-C.; Kania, P.; Müller, H. S. P.; Menten, K. M.; Urban, Š. "Millimeter wave spectrum and search for vinyl isocyanate toward Sgr B2(N) with ALMA," *Astronomy and Astrophysics*, 666: A50, 2022.
- Velović, Velibor; Filipović, M. D.; Barnes, L.; Norris, R. P.; Tremblay, C. D.; Heald, G.; Rudnick, L.; Shabala, S. S.; Pannuti, T. G.; Andernach, H.; Titov, O.; Waddell, S. G. H.; Koribalski, B. S.; Grupe, D.; Jarrett, T.; Alsaberi, R. Z. E.; Carretti, E.; Collier, J. D.; Einecke, S.; Galvin, T. J.; Hotan, A.; Manojlović, P.; Marvil, J.; Nandra, K.; Reiprich, T. H.; Rowell, G.; Salvato, M.; Whiting, M. "Collimation of the kiloparsec-scale radio jets in NGC 2663," *Monthly Notices of the Royal Astronomical Society*, 516: 1865, 2022.
- Vietri, A.; Järvelä, E.; Berton, M.; Ciroi, S.; Congiu, E.; Chen, S.; Di Mille, F. "Spectacular 240 kpc double-sided relativistic jets in a spiral-hosted narrow-line Seyfert 1 galaxy," *Astronomy and Astrophysics*, 662: A20, 2022.
- Villanueva, Vicente; Bolatto, Alberto D.; Vogel, Stuart; Brown, Tobias; Wilson, Christine D.; Zabel, Nikki; Ellison, Sara; Stevens, Adam R. H.; Jiménez Donaire, María Jesús; Spekkens, Kristine; Tharp, Mallory; Davis, Timothy A.; Parker, Laura C.; Roberts, Ian D.; Basra, Dhruv; Boselli, Alessandro; Catinella, Barbara; Chung, Aeere; Cortese, Luca; Lee, Bumhyun; Watts, Adam "VERTICO. IV. Environmental Effects on the Gas Distribution and Star Formation Efficiency of Virgo Cluster Spirals," *The Astrophysical Journal*, 940: 176, 2022.
- Villaraos, D.; Herrera-Aguilar, A.; Nucamendi, U.; González-Juárez, G.; Lizardo-Castro, R. "A general relativistic mass-to-distance ratio for a set of megamaser AGN black holes," *Monthly Notices of the Royal Astronomical Society*, 517: 4213, 2022.
- Villanave, M.; Stapelfeldt, K. R.; Duchêne, G.; Ménard, F.; Lambrechts, M.; Sierra, A.; Flores, C.; Dent, W. R. F.; Wolff, S.; Ribas, Á.; Benisty, M.; Cuello, N.; Pinte, C. "A Highly Settled Disk around Oph163131," *The Astrophysical Journal*, 930: 11, 2022.
- Vioque, Miguel; Oudmaijer, René D.; Wichittanakom, Chumpon; Mendigutía, Ignacio; Baines, Deborah; Panić, Olja; Iglesias, Daniela; Miley, James; Pérez-Martínez, Ricardo "Identification and Spectroscopic Characterization of 128 New Herbig Stars," *The Astrophysical Journal*, 930: 39, 2022.
- Vizgan, David; Meredith Hughes, A.; Carter, Evan S.; Flaherty, Kevin M.; Pan, Margaret; Chiang, Eugene; Schlichting, Hilke; Wilner, David J.; Andrews, Sean M.; Carpenter, John M.; Moor, Attila; Macgregor, Meredith A. "Multiwavelength Vertical Structure in the AU Mic Debris Disk: Characterizing the Collisional Cascade," *The Astrophysical Journal*, 935: 131, 2022.
- Vleeschower, L.; Stappers, B. W.; Bailes, M.; Barr, E. D.; Kramer, M.; Ransom, S.; Ridolfi, A.; Krishnan, V. Venkatraman; Possenti, A.; Keith, M. J.; Burgay, M.; Freire, P. C. C.; Spiewak, R.; Champion, D. J.; Bezuidenhout, M. C.; Nițu, I. C.; Chen, W.; Parthasarathy, A.; Decesar, M. E.; Buchner, S.; Stairs, I. H.; Hessels, J. W. T. "Discoveries and Timing of Pulsars in NGC 6440," *Monthly Notices of the Royal Astronomical Society*, 513: 1386, 2022.
- Vurgun, Eda; Linares, Manuel; Ransom, Scott; Papitto, Alessandro; Bogdanov, Slavko; Bozzo, Enrico; Rea, Nanda; García-Senz, Domingo; Freire, Paulo; Stairs, Ingrid "The Neutron Star Population in M28: A Joint Chandra/GBT Look at Pulsar Paradise," *The Astrophysical Journal*, 941: 76, 2022.
- Wahl, H. M.; Mclaughlin, M. A.; Gentile, P. A.; Jones, M. L.; Spiewak, R.; Arzoumanian, Z.; Crowter, K.; Demorest, P. B.; Decesar, M. E.; Dolch, T.; Ellis, J. A.; Ferdman, R. D.; Ferrara, E. C.; Fonseca, E.; Garver-Daniels, N.; Jones, G.; Lam, M. T.; Levin, L.; Lewandowska, N.; Lorimer, D. R.; Lynch, R. S.; Madison, D. R.; Ng, C.; Nice, D. J.; Pennucci, T. T.; Ransom, S. M.; Ray, P.; Stairs, I. H.; Stovall, K.; Swiggum, J. K.; Zhu, W. W. "The NANOGrav 12.5 yr Data Set: Polarimetry and Faraday Rotation Measures from Observations of Millisecond Pulsars with the Green Bank Telescope," *The Astrophysical Journal*, 926: 168, 2022.

## APPENDIX A: PUBLICATIONS

- Wallace, J.; Battersby, C.; Mills, E. A. C.; Henshaw, J. D.; Sormani, M. C.; Ginsburg, A.; Barnes, A. T.; Hatchfield, H. P.; Glover, S. C. O.; Anderson, L. D. "ALMA Uncovers Highly Filamentary Structure toward the Sgr E Region," *The Astrophysical Journal*, 939: 58, 2022.
- Walter, Fabian; Neeleman, Marcel; Decarli, Roberto; Venemans, Bram; Meyer, Romain; Weiss, Axel; Bañados, Eduardo; Bosman, Sarah E. I.; Carilli, Chris; Fan, Xiaohui; Riechers, Dominik; Rix, Hans-Walter; Thompson, Todd A. "ALMA 200 pc Imaging of a  $z \approx 7$  Quasar Reveals a Compact, Disk-like Host Galaxy," *The Astrophysical Journal*, 927: 21, 2022.
- Wang, Qiaohong; Taylor, Stephen R. "Controlling outlier contamination in multimessenger time-domain searches for supermassive binary black holes," *Monthly Notices of the Royal Astronomical Society*, 516: 5874, 2022.
- Wang, Tsan-Ming; Magnelli, Benjamin; Schinnerer, Eva; Liu, Daizhong; Modak, Ziad Aziz; Jiménez-Andrade, Eric Faustino; Karoumpis, Christos; Kokorev, Vasily; Bertoldi, Frank "A3COSMOS: A census on the molecular gas mass and extent of main-sequence galaxies across cosmic time," *Astronomy and Astrophysics*, 660: A142, 2022.
- Wang, Xuezheng; Jiang, Wu; Shen, Zhiqiang; Huang, Lei; Hada, Kazuhiro; Cui, Yuzhu; Lu, Ru-Sen "Multifrequency VLBI Observations of the M84 Inner Jet/Counterjet," *The Astrophysical Journal*, 941: 140, 2022.
- Wang, Yuwei; Qiu, Keping; Cao, Yue; Cheng, Yu; Liu, Junhao; Hu, Bo "Surveys of Clumps, Cores, and Condensations in Cygnus X. II. Radio Properties of Massive Dense Cores," *The Astrophysical Journal*, 927: 185, 2022.
- Weaver, Zachary R.; Jorstad, Svetlana G.; Marscher, Alan P.; Morozova, Daria A.; Troitsky, Ivan S.; Agudo, Iván; Gómez, José L.; Lähteenmäki, Anne; Tammi, Joni; Tornikoski, Merja "Kinematics of Parsec-scale Jets of Gamma-Ray Blazars at 43 GHz during 10 yr of the VLBA-BU-BLAZAR Program," *The Astrophysical Journal Supplement Series*, 260: 12, 2022.
- Wenner, Nycolie; Sarma, A. P.; Momjian, E. "Long-term Variability of Class I Methanol Masers in the High-mass Star-forming Region DR21(OH)," *The Astrophysical Journal*, 930: 114, 2022.
- Westmeier, T.; Deg, N.; Spekkens, K.; Reynolds, T. N.; Shen, A. X.; Gaudet, S.; Goliath, S.; Huynh, M. T.; Venkataraman, P.; Lin, X.; O'Beirne, T.; Catinella, B.; Cortese, L.; Dénes, H.; Elagali, A.; For, B.-Q.; Józsa, G. I. G.; Howlett, C.; Van Der Hulst, J. M.; Jurek, R. J.; Kamphuis, P.; Kilborn, V. A.; Kleiner, D.; Koribalski, B. S.; Lee-Waddell, K.; Murugesan, C.; Rhee, J.; Serra, P.; Shao, L.; Staveley-Smith, L.; Wang, J.; Wong, O. I.; Zwaan, M. A.; Allison, J. R.; Anderson, C. S.; Ball, Lewis; Bock, D. C.-J.; Brodrick, D.; Bunton, J. D.; Cooray, F. R.; Gupta, N.; Hayman, D. B.; Mahony, E. K.; Moss, V. A.; Ng, A.; Pearce, S. E.; Raja, W.; Roxby, D. N.; Voronkov, M. A.; Warhurst, K. A.; Courtois, H. M.; Said, K. "WALLABY pilot survey: Public release of HI data for almost 600 galaxies from phase 1 of ASKAP pilot observations," *Publications of the Astronomical Society of Australia*, 39: e058, 2022.
- Wethers, Clare F.; Acharya, Nischal; De Propriis, Roberto; Kotilainen, Jari; Baldry, Ivan K.; Brough, Sarah; Driver, Simon P.; Graham, Alister W.; Holwerda, Benne W.; Hopkins, Andrew M.; López-Sánchez, Angel R.; Loveday, Jonathan; Philipps, Steven; Pimbblet, Kevin A.; Taylor, Edward; Wang, Lingyu; Wright, Angus H. "Galaxy and Mass Assembly (GAMA): The Weak Environmental Dependence of Quasar Activity at  $0.1 < z < 0.35$ ," *The Astrophysical Journal*, 928: 192, 2022.
- Weżgowiec, M.; Beck, R.; Hanasz, M.; Soida, M.; Ehle, M.; Dettmar, R.-J.; Urbanik, M. "Magnetic fields and hot gas in M 101," *Astronomy and Astrophysics*, 664: A108, 2022.
- Weżgowiec, M.; Beck, R.; Hanasz, M.; Soida, M.; Ehle, M.; Dettmar, R.-J.; Urbanik, M. "Hot magnetic halo of NGC 628 (M 74)," *Astronomy and Astrophysics*, 665: A64, 2022.
- White, E.; Ghigo, F. D.; Prestage, R. M.; Frayer, D. T.; Maddalena, R. J.; Wallace, P. T.; Brandt, J. J.; Egan, D.; Nelson, J. D.; Ray, J. "Green Bank Telescope: Overview and analysis of metrology systems and pointing performance," *Astronomy and Astrophysics*, 659: A113, 2022.
- Wielgus, M.; Moscibrodzka, M.; Vos, J.; Gelles, Z.; Martí-Vidal, I.; Farah, J.; Marchili, N.; Goddi, C.; Messias, H. "Orbital motion near Sagittarius A". Constraints from polarimetric ALMA observations," *Astronomy and Astrophysics*, 665: L6, 2022.
- Wielgus, Maciek; Marchili, Nicola; Martí-Vidal, Iván; Keating, Garrett K.; Ramakrishnan, Venkatesh; Tiede, Paul; Fomalont, Ed; Issaoun, Sara; Neilsen, Joey; Nowak, Michael A.; Blackburn, Lindy; Gammie, Charles F.; Goddi, Ciriaco; Haggard, Daryl; Lee, Daeyoung; Moscibrodzka, Monika; Tetarenko, Alexandra J.; Bower, Geoffrey C.; Chan, Chi-Kwan; Chatterjee, Koushik; Chesler, Paul M.; Dexter, Jason; Doeleman, Sheperd S.; Georgiev, Boris; Gurwell, Mark; Johnson, Michael D.; Marrone, Daniel P.; Mus, Alejandro; Psaltis, Dimitrios; Ripperda, Bart; Witzel, Gunther; Akiyama, Kazunori; Alberdi, Antxon; Alef, Walter; Carlos Algaba, Juan; Anantua, Richard; Asada, Keiichi; Azulay, Rebecca; Bach, Uwe; Baczo, Anne-Kathrin; Ball, David; Baloković, Mislav; Barrett, John; Bauböck, Michi; Benson, Bradford A.; Bintley, Dan; Blundell, Raymond; Boland, Wilfred; Bouman, Katherine L.; Boyce, Hope; Bremer, Michael; Brinkerink, Christiaan D.; Brissenden, Roger; Britzen, Silke; Broderick, Avery E.; Brogiere, Dominique; Bronzwaer, Thomas; Bustamante, Sandra; Byun, Do-Young; Carlstrom, John E.; Ceccobello, Chiara; Chael, Andrew; Chatterjee, Shami; Chen, Ming-Tang; Chen, Yongjun; Cho, Ilje; Christian, Pierre; Conroy, Nicholas S.; Conway, John E.; Cordes, James M.; Crawford, Thomas M.; Crew, Geoffrey B.; Cruz-Osorio, Alejandro; Cui, Yuzhu; Davelaar, Jordy; De Laurentis, Mariafelicia; Deane, Roger; Dempsey, Jessica; Desvignes, Gregory; Dhruv, Vedant; Dzib, Sergio A.; Eatough, Ralph P.; Emami, Razieh; Falcke, Heino; Farah, Joseph; Fish, Vincent L.; Alyson Ford, H.; Fraga-Encinas, Raquel; Freeman, William T.; Friberg, Per; Fromm, Christian M.; Fuentes, Antonio; Galison, Peter; García, Roberto; Gentaz, Olivier; Gold, Roman; Gómez-Ruiz, Arturo I.; Gómez, José L.; Gu, Minfeng; Hada, Kazuhiro; Haworth, Kari; Hecht, Michael H.; Hesper, Ronald; Ho, Luis C.; Ho, Paul; Honma, Mareki; Huang, Chih-Wei L.; Huang, Lei; Hughes, David H.; Ikeda, Shiro; Violette Impellizzeri, C. M.; Inoue, Makoto; James, David J.; Jannuzi, Buell T.; Janssen, Michael; Jeter, Britton; Jiang, Wu; Jiménez-Rosales, Alejandra; Jorstad, Svetlana; Joshi, Abhishek V.; Jung, Taehyun; Karami, Mansour; Karuppusamy, Ramesh; Kawashima, Tomohisa; Kettenis, Mark; Kim, Dong-Jin; Kim, Jae-Young; Kim, Jongsoo; Kim, Junhan; Kino, Motoki; Koay, Jun Yi; Kocherlakota, Prashant; Kofuji, Yutaro; Koch, Patrick M.; Koyama, Shoko; Kramer, Carsten; Kramer, Michael; Krichbaum, Thomas P.; Kuo, Cheng-Yu; La Bella, Noemi; Lauer, Tod R.; Lee, Sang-Sung; Kin Leung, Po; Levis, Aviad; Li, Zhiyuan; Lico, Rocco; Lindahl, Greg; Lindqvist, Michael; Lisakov, Mikhail; Liu, Jun; Liu, Kuo; Liuzzo, Elisabetta; Lo, Wen-Ping; Lobanov, Andrei P.; Loinard, Laurent; Lonsdale, Colin; Lu, Ru-Sen; Mao, Jirong; Markoff, Sera; Marscher, Alan P.; Matsushita, Satoki; Matthews, Lynn D.; Medeiros, Lia; Menten, Karl M.; Michalik, Daniel; Mizuno, Izumi; Mizuno, Yosuke; Moran, James M.; Moriyama, Kotaro; Müller, Cornelia; Musoke, Gibwa; Myserlis, Ioannis; Nadolski, Andrew; Nagai, Hiroshi; Nagar, Neil M.; Nakamura, Masanori; Narayan, Ramesh; Narayanan, Gopal; Natarajan, Iniyar; Nathanail, Antonios; Navarro Fuentes, Santiago; Neri, Roberto; Ni, Chunchong; Noutsos, Aristeidis; Oh, Junghwan; Okino, Hiroki; Olivares, Héctor; Ortiz-León, Gisela N.; Oyama, Tomoaki; Özel, Feryal; Palumbo, Daniel C. M.; Filippas Paraschos, Georgios; Park, Jongho; Parsons, Harriet; Patel, Nimesh; Pen, Ue-Li; Pesce, Dominic W.; Piétu, Vincent; Plambeck, Richard; Popstefanija, Aleksandar; Porth, Oliver; Pötzl, Felix M.; Prather, Ben; Preciado-López, Jorge A.; Pu, Hung-Yi; Rao, Ramprasad; Rawlings, Mark G.; Raymond, Alexander W.; Rezzolla, Luciano; Ricarte, Angelo; Roelofs, Freek; Rogers, Alan; Ros, Eduardo; Romero-Canizales, Cristina; Roshanineshat, Arash; Rottmann, Helge; Roy, Alan L.; Ruiz, Ignacio; Ruszczyk, Chet; Rygl, Kazi L. J.; Sánchez, Salvador; Sánchez-Argüelles, David; Sánchez-Portal, Miguel; Sasada, Mahito; Satapathy, Kaushik; Savolainen, Tuomas; Peter Schloerb, F.; Schuster, Karl-Friedrich; Shao, Lijing; Shen, Zhiqiang; Small, Des; Won Sohn, Bong; Soohoo, Jason; Souccar, Kamal; Sun, He; Tazaki, Fumie; Tilanus, Remo P. J.; Titus, Michael; Torne, Pablo; Traianou, Efthalia;

- Trent, Tyler; Trippe, Sascha; Van Bemmell, Ilse; Jan Van Langevelde, Huib; Van Rossum, Daniel R.; Vos, Jesse; Wagner, Jan; Ward-Thompson, Derek; Wardle, John; Weintraub, Jonathan; Wex, Norbert; Wharton, Robert; Wiik, Kaj; Wondrak, Michael F.; Wong, George N.; Wu, Qingwen; Yamaguchi, Paul; Yoon, Doosoo; Young, André; Young, Ken; Younsi, Ziri; Yuan, Feng; Yuan, Ye-Fei; Anton Zensus, J.; Zhang, Shuo; Zhao, Guang-Yao; Zhao, Shan-Shan "Millimeter Light Curves of Sagittarius A\* Observed during the 2017 Event Horizon Telescope Campaign," *The Astrophysical Journal*, 930: L19, 2022.
- Wilkins, Olivia H.; Blake, Geoffrey A. "Relationship between CH3OD Abundance and Temperature in the Orion KL Nebula," *Journal of Physical Chemistry A*, 126: 6473, 2022.
- Wilkins, Olivia H.; Carroll, P. Brandon; Blake, Geoffrey A. "Mapping Physical Parameters in Orion KL at High Spatial Resolution," *The Astrophysical Journal*, 924: 4, 2022.
- Williams, Bethan A.; Walker, Daniel L.; Longmore, Steven N.; Barnes, A. T.; Battersby, Cara; Garay, Guido; Ginsburg, Adam; Gomez, Laura; Henshaw, Jonathan D.; Ho, Luis C.; Kruijssen, J. M. Diederik; Lu, Xing; Mills, Elisabeth A. C.; Petkova, Maya A.; Zhang, Qizhou "The initial conditions for young massive cluster formation in the Galactic Centre: convergence of large-scale gas flows," *Monthly Notices of the Royal Astronomical Society*, 514: 578, 2022.
- Williams, Christina C.; Alberts, Stacey; Spilker, Justin S.; Noble, Allison G.; Stefanon, Mauro; Willmer, Christopher N. A.; Bezanson, Rachel; Narayanan, Desika; Whitaker, Katherine E. "ALMA Measures Molecular Gas Reservoirs Comparable to Field Galaxies in a Low-mass Galaxy Cluster at  $z = 1.3$ ," *The Astrophysical Journal*, 929: 35, 2022.
- Williams, D. R. A.; Motta, S. E.; Fender, R.; Miller-Jones, J. C. A.; Neilsen, J.; Allison, J. R.; Bright, J.; Heywood, I.; Jacob, P. F. L.; Rhodes, L.; Tremou, E.; Woudt, P.; Van Den Eijnden, J.; Carotenuto, F.; Green, D. A.; Titterton, D.; Van Der Horst, A. J.; Saikia, P. "Radio observations of the Black Hole X-ray Binary EXO 1846-031 re-awakening from a 34-year slumber," *Monthly Notices of the Royal Astronomical Society*, 517: 2801, 2022.
- Williams, G. M.; Cyganowski, C. J.; Brogan, C. L.; Hunter, T. R.; Ilee, J. D.; Nazari, P.; Kruijssen, J. M. D.; Smith, R. J.; Bonnell, I. A. "ALMA observations of the Extended Green Object G19.01-0.03 - I. A Keplerian disc in a massive protostellar system," *Monthly Notices of the Royal Astronomical Society*, 509: 748-762, 2022.
- Williams, Thomas G.; Sun, Jiayi; Barnes, Ashley T.; Schinnerer, Eva; Henshaw, Jonathan D.; Meidt, Sharon E.; Querejeta, Miguel; Watkins, Elizabeth J.; Bigiel, Frank; Blanc, Guillermo A.; Boquien, Médéric; Cao, Yixian; Chevance, Mélanie; Egorov, Oleg V.; Emsellem, Eric; Glover, Simon C. O.; Grasha, Kathryn; Hassani, Hamid; Jeffreson, Sarah; Jiménez-Donaire, María J.; Kim, Jaeyeon; Klessen, Ralf S.; Kreckel, Kathryn; Kruijssen, J. M. Diederik; Larson, Kirsten L.; Leroy, Adam K.; Liu, Daizhong; Pessa, Ismael; Pety, Jérôme; Pinna, Francesca; Rosolowsky, Erik; Sandstrom, Karin M.; Smith, Rowan; Sormani, Mattia C.; Stuber, Sophia; Thilker, David A.; Whitmore, Bradley C. "PHANGS-JWST First Results: Spurring on Star Formation: JWST Reveals Localized Star Formation in a Spiral Arm Spur of NGC 628," *The Astrophysical Journal*, 941: L27, 2022.
- Witstok, Joris; Smit, Renske; Maiolino, Roberto; Kumari, Nimisha; Aravena, Manuel; Boogaard, Leindert; Bouwens, Rychard; Carniani, Stefano; Hodge, Jacqueline A.; Jones, Gareth C.; Stefanon, Mauro; Van Der Werf, Paul; Schouws, Sander "Dual constraints with ALMA: new [O III] 88- $\mu$ m and dust-continuum observations reveal the ISM conditions of luminous LBGs at  $z = 7$ ," *Monthly Notices of the Royal Astronomical Society*, 515: 1751, 2022.
- Wolz, Laura; Poursisdou, Alkistis; Masui, Kiyoshi W.; Chang, Tzu-Ching; Bautista, Julian E.; Müller, Eva-Maria; Avila, Santiago; Bacon, David; Percival, Will J.; Cunnington, Steven; Anderson, Chris; Chen, Xuelei; Kneib, Jean-Paul; Li, Yi-Chao; Liao, Yu-Wei; Pen, Ue-Li; Peterson, Jeffrey B.; Rossi, Graziano; Schneider, Donald P.; Yadav, Jaswant; Zhao, Gong-Bo "H I constraints from the cross-correlation of eBOSS galaxies and Green Bank Telescope intensity maps," *Monthly Notices of the Royal Astronomical Society*, 510: 3495-3511, 2022.
- Wong, Tony; Oudshoorn, Luuk; Sofovich, Elyahu; Green, Alex; Shah, Charmi; Indebetouw, Rémy; Meixner, Margaret; Hacar, Alvaro; Nayak, Omnarayani; Tokuda, Kazuki; Bolatto, Alberto D.; Chevance, Mélanie; De Marchi, Guido; Fukui, Yasuo; Hirschauer, Alec S.; Jameson, K. E.; Kalari, Venu; Lebouteiller, Vianney; Looney, Leslie W.; Madden, Suzanne C.; Onishi, Toshikazu; Roman-Duval, Julia; Rubio, Mónica; Tielens, A. G. G. M. "The 30 Doradus Molecular Cloud at 0.4 pc Resolution with the Atacama Large Millimeter/submillimeter Array: Physical Properties and the Boundedness of CO-emitting Structures," *The Astrophysical Journal*, 932: 47, 2022.
- Wong, Yi Hang Valerie; Wang, Poya; Hashimoto, Tetsuya; Takagi, Toshinobu; Goto, Tomotsugu; Kim, Seong Jin; Wu, Cossas K.-W.; On, Alvina Y. L.; Santos, Daryl Joe D.; Lu, Ting-Yi; Kilerci-Eser, Ece; Ho, Simon C.-C.; Hsiao, Tiger Y.-Y. "ALMA Detections of [O III] and [C II] Emission Lines From A1689-zD1 at  $z = 7.13$ ," *The Astrophysical Journal*, 929: 161, 2022.
- Wootten, Alwyn; Bentley, Rory O.; Baldwin, J.; Combes, F.; Fabian, A. C.; Ferland, G. J.; Loh, E.; Salome, P.; Shingledecker, C. N.; Castro-Carrizo, A. "Dense Molecular Clouds in the Crab Supernova Remnant," *The Astrophysical Journal*, 925: 59, 2022.
- Wright, Melvyn; Bally, John; Hirota, Tomoya; Miller, Kyle; Harding, Tyler; Colletuori, Keira; Ginsburg, Adam; Goddi, Ciriaco; Mcguire, Brett "Structure of the Source I Disk in Orion-KL," *The Astrophysical Journal*, 924: 107, 2022.
- Wrobel, J. M.; Lazio, T. J. W. "Toward Astrometric Constraints on a Supermassive Black Hole Binary in the Early-type Galaxy NGC 4472," *The Astrophysical Journal*, 931: 12, 2022.
- Wu, Gang; Martínez-Delgado, David; Henkel, Christian; Kroupa, Pavel; Walter, Fabian; Krieger, Nico; Bolatto, Alberto D.; Robishaw, Timothy; Simon, Joshua D.; Ibáñez Pérez, Álvaro; Menten, Karl M.; Esmibek, Jarken "H I mapping of the Leo Triplet. Morphologies and kinematics of tails and bridges," *Astronomy and Astrophysics*, 658: A25, 2022.
- Wu, Hong; Wu, Zhongzu; Sotnikova, Yu.; Chen, Yongjun; Zhang, Bo; Mufakharov, T.; Shen, Zhiqiang; Chen, Xi; Mikhailov, A.; Mingaliev, M.; Han, Xianming L.; Misra, Prabhakar "Radio properties of the OH megamaser galaxy IIZw 096," *Astronomy and Astrophysics*, 661: A125, 2022.
- Wu, Ya-Lin; Bowler, Brendan P.; Sheehan, Patrick D.; Close, Laird M.; Eisner, Joshua A.; Best, William M. J.; Ward-Duong, Kimberly; Zhu, Zhaohuan; Kraus, Adam L. "ALMA Discovery of a Disk around the Planetary-mass Companion SR 12 c," *The Astrophysical Journal*, 930: L3, 2022.
- Wu, Zihao; Ho, Luis C.; Zhuang, Ming-Yang "An Elusive Population of Massive Disk Galaxies Hosting Double-lobed Radio-loud Active Galactic Nuclei," *The Astrophysical Journal*, 941: 95, 2022.
- Xiao, H. B.; Zhu, J. T.; Fan, J. H.; Pei, Z. Y.; Luo, Z. J.; Zhang, S. H. "The jet apparent motion and central engine study of Fermi blazars," *Monthly Notices of the Royal Astronomical Society*, 517: 4202, 2022.
- Xiao, M.-Y.; Wang, T.; Elbaz, D.; Iono, D.; Lu, X.; Bing, L.-J.; Daddi, E.; Magnelli, B.; Gómez-Guijarro, C.; Bournaud, F.; Gu, Q.-S.; Jin, S.; Valentino, F.; Zanella, A.; Gobat, R.; Martin, S.; Brammer, G.; Kohno, K.; Schreiber, C.; Ciesla, L.; Yu, X.-L.; Okumura, K. "Starbursts with suppressed velocity dispersion revealed in a forming cluster at  $z = 2.51$ ," *Astronomy and Astrophysics*, 664: A63, 2022.
- Xu, J.; Han, J. L. "Evidence for Strong Intracluster Magnetic Fields in the Early Universe," *The Astrophysical Journal*, 926: 65, 2022.
- Xu, Shuangjing; Zhang, Bo; Reid, Mark J.; Zheng, Xingwu; Wang, Guangli; Jung, Taehyun "A Milliarsecond-accurate Position for Sagittarius A\*," *The Astrophysical Journal*, 940: 15, 2022.
- Xu, Zhilei; Hewitt, Jacqueline N.; Chen, Kai-Feng; Kim, Honggeun; Dillon, Joshua S.; Kern, Nicholas S.; Morales, Miguel F.; Hazelton, Bryna J.; Byrne, Ruby; Fagnoni, Nicolas; Acedo, Eloy De Lera; Abdurashidova, Zara; Adams, Tyrone; Aguirre, James E.; Alexander, Paul; Ali, Zaki S.; Baartman, Rushelle; Balfour, Yanga; Beardsley, Adam P.; Bernardi, Gianni; Billings, Tashalee S.; Bowman, Judd D.; Bradley, Richard F.;

## APPENDIX A: PUBLICATIONS

- Bull, Philip; Burba, Jacob; Carey, Steven; Carilli, Chris L.; Cheng, Carina; Deboer, David R.; Dexter, Matt; Eksteen, Nico; Ely, John; Ewall-Wice, Aaron; Fritz, Randall; Furlanetto, Steven R.; Gale-Sides, Kingsley; Glendenning, Brian; Gorthi, Deepthi; Greig, Bradley; Grobbelaar, Jasper; Halday, Ziyaad; Hickish, Jack; Jacobs, Daniel C.; Julius, Austin; Kariseb, Maccalvin; Kerrigan, Joshua; Kittiwisit, Piyanat; Kohn, Saul A.; Kolopanis, Matthew; Lanman, Adam; La Plante, Paul; Liu, Adrian; Loots, Anita; Ma, Yin-Zhe; Edward Macmahon, David Harold; Malan, Lourence; Malgas, Cresshim; Malgas, Keith; Marero, Bradley; Martinot, Zachary E.; Mesinger, Andrei; Molewa, Mathakane; Mosiane, Tshegofalang; Murray, Steven G.; Neben, Abraham R.; Nikolic, Bojan; Nuwegeld, Hans; Parsons, Aaron R.; Patra, Nipanjana; Pieterse, Samantha; Pober, Jonathan C.; Razavi-Ghods, Nima; Robnett, James; Rosie, Kathryn; Sims, Peter; Smith, Craig; Swarts, Hilton; Thyagarajan, Nithyanandan; Van Wyngaarden, Pieter; Williams, Peter K. G.; Zheng, Haoxuan; Hera Collaboration "Direct Optimal Mapping for 21 cm Cosmology: A Demonstration with the Hydrogen Epoch of Reionization Array," *The Astrophysical Journal*, 938: 128, 2022.
- Xue, Xiao; Xia, Zi-Qing; Zhu, Xingjiang; Zhao, Yue; Shu, Jing; Yuan, Qiang; Bhat, N. D. Ramesh; Cameron, Andrew D.; Dai, Shi; Feng, Yi; Goncharov, Boris; Hobbs, George; Howard, Eric; Manchester, Richard N.; Parthasarathy, Aditya; Reardon, Daniel J.; Russell, Christopher J.; Shannon, Ryan M.; Spiewak, Renée; Thyagarajan, Nithyanandan; Wang, Jingbo; Zhang, Lei; Zhang, Songbo; Ppta Collaboration "High-precision search for dark photon dark matter with the Parkes Pulsar Timing Array," *Physical Review Research*, 4: L012022, 2022.
- Yadav, R. K.; Samal, M. R.; Semenko, E.; Zavagno, A.; Vaddi, S.; Prajapati, P.; Ojha, D. K.; Pandey, A. K.; Ridsdill-Smith, M.; Jose, J.; Patra, S.; Dutta, S.; Irawati, P.; Sharma, S.; Sahu, D. K.; Panwar, N. "A Comprehensive Study of the Young Cluster IRAS 05100+3723: Properties, Surrounding Interstellar Matter, and Associated Star Formation," *The Astrophysical Journal*, 926: 16, 2022.
- Yamato, Yoshihide; Furuya, Kenji; Aikawa, Yuri; Persson, Magnus V.; Tobin, John J.; Jørgensen, Jes K.; Kama, Mihkel "The First Interferometric Measurements of NH<sub>2</sub>/NH<sub>3</sub> Ratio in Hot Corinos," *The Astrophysical Journal*, 941: 75, 2022.
- Yan, Y. T.; Henkel, C.; Menten, K. M.; Gong, Y.; Nguyen, H.; Ott, J.; Ginsburg, A.; Wilson, T. L.; Brunthaler, A.; Belloche, A.; Zhang, J. S.; Budaiev, N.; Jeff, D. "Discovery of non-metastable ammonia masers in Sagittarius B<sub>2</sub>," *Astronomy and Astrophysics*, 666: L15, 2022.
- Yan, Y. T.; Henkel, C.; Menten, K. M.; Gong, Y.; Ott, J.; Wilson, T. L.; Wootten, A.; Brunthaler, A.; Zhang, J. S.; Chen, J. L.; Yang, K. "Discovery of ammonia (9,6) masers in two high-mass star-forming regions," *Astronomy and Astrophysics*, 659: A5, 2022.
- Yang, Guang; Brandt, W. N.; Alexander, David M.; Boquien, Médéric; Ni, Qingling; Papovich, Casey; Spilker, Justin S.; Vito, Fabio; Walsh, Jonelle L.; Zhang, Chengpeng "Does the Lockstep Growth between Black Holes and Bulges Create Their Mass Relation?," *The Astrophysical Journal*, 940: 146, 2022.
- Yang, Jun; Chen, Yongjun; Gurvits, Leonid I.; Paragi, Zsolt; Yang, Aiyuan; Yang, Xiaolong; Shen, Zhiqiang "Structural and spectral properties of Galactic plane variable radio sources," *Monthly Notices of the Royal Astronomical Society*, 511: 280, 2022.
- Yang, Jun; Yang, Xiaolong; Wrobel, Joan M.; Paragi, Zsolt; Gurvits, Leonid I.; Ho, Luis C.; Nyland, Kristina; Fan, Lulu; Tafuya, Daniel "Is there a sub-parsec-scale jet base in the nearby dwarf galaxy NGC 4395?," *Monthly Notices of the Royal Astronomical Society*, 514: 6215, 2022.
- Yang, Lei; Shu, Xinwen; Zhang, Fabao; Chandola, Yogesh; Liu, Daizhong; Liu, Yi; Gu, Minfeng; Giustini, Margherita; Jiang, Ning; Li, Ya-Ping; Li, Di; Elbaz, David; Juneau, Stephanie; Pannella, Maurilio; Sun, Luming; Tang, Ningyu; Wang, Tinggui; Zhou, Hongyan "Compact and Variable Radio Emission from an Active Galaxy with Supersoft X-Ray Emission," *The Astrophysical Journal*, 935: 115, 2022.
- Yang, Xiaolong; Ji, Jialu; Joshi, Ravi; Yang, Jun; An, Tao; Wang, Ran; Ho, Luis C.; Roberts, David H.; Saripalli, Lakshmi "The X-shaped Radio Galaxy J0725+5835 is Associated with an AGN Pair," *The Astrophysical Journal*, 933: 98, 2022.
- Yang, Xiaolong; Mohan, Prashanth; Yang, Jun; Ho, Luis C.; Aditya, J. N. H. S.; Zhang, Shaohua; Jaiswal, Sumit; Yang, Xiaofeng "Radio Observations of Four Active Galactic Nuclei Hosting Intermediate-mass Black Hole Candidates: Studying the Outflow Activity and Evolution," *The Astrophysical Journal*, 941: 43, 2022.
- Yang, Xiaolong; Wang, Ruiling; Guo, Quan "A compact symmetric ejection from the low mass AGN in the LINER galaxy NGC 4293," *Monthly Notices of the Royal Astronomical Society*, 517: 4959, 2022.
- Yang, Yang; Irwin, Judith; Li, Jiangtao; Wiegert, Theresa; Wang, Q. Daniel; Sun, Wei; Damas-Segovia, A.; Li, Zhiyuan; Shen, Zhiqiang; Walterbos, René A. M.; Vargas, Carlos J. "CHANG-ES. XXIV. First Detection of a Radio Nuclear Ring and Potential LLAGN in NGC 5792," *The Astrophysical Journal*, 927: 4, 2022.
- Yang, Yao-Lun; Green, Joel D.; Pontoppidan, Klaus M.; Bergner, Jennifer B.; Cleeves, L. Ilse; Evans, Neal J., II; Garrod, Robin T.; Jin, Mihwa; Kim, Chul Hwan; Kim, Jaeyeong; Lee, Jeong-Eun; Sakai, Nami; Shingledecker, Christopher N.; Shope, Brielle; Tobin, John J.; Van Dishoeck, Ewine F. "CORINOS. I. JWST/MIRI Spectroscopy and Imaging of a Class 0 Protostar IRAS 15398-3359," *The Astrophysical Journal*, 941: L13, 2022.
- Yanzen, Vanessa; Masqué, Josep M.; Dzib, Sergio A.; Rodríguez, Luis F.; Medina, S. -N. X.; Kurtz, Stan; Loinard, Laurent; Trinidad, Miguel A.; Menten, Karl M.; Rodríguez-Rico, Carlos A. "The Population of Compact Radio Sources in M17," *The Astronomical Journal*, 163: 276, 2022.
- Yao, Yuhang; Ho, Anna Y. Q.; Medvedev, Pavel; Nayana, A. J.; Perley, Daniel A.; Kulkarni, S. R.; Chandra, Poonam; Sazonov, Sergey; Gilfanov, Marat; Khorunzhev, Georgii; Khatami, David K.; Sunyaev, Rashid "The X-Ray and Radio Loud Fast Blue Optical Transient AT2020mrf: Implications for an Emerging Class of Engine-driven Massive Star Explosions," *The Astrophysical Journal*, 934: 104, 2022.
- Yao, Yuhang; Lu, Wenbin; Guolo, Muryel; Pasham, Dheeraj R.; Gezari, Suvi; Gilfanov, Marat; Gendreau, Keith C.; Harrison, Fiona; Cenko, S. Bradley; Kulkarni, S. R.; Miller, Jon M.; Walton, Dominic J.; García, Javier A.; Velzen, Sjoert Van; Alexander, Kate D.; Miller-Jones, James C. A.; Nicholl, Matt; Hammerstein, Erica; Medvedev, Pavel; Stern, Daniel; Ravi, Vikram; Sunyaev, R.; Bloom, Joshua S.; Graham, Matthew J.; Kool, Erik C.; Mahabal, Ashish A.; Masci, Frank J.; Purdum, Josiah; Rusholme, Ben; Sharma, Yashvi; Smith, Roger; Sollerman, Jesper "The Tidal Disruption Event AT2021ehb: Evidence of Relativistic Disk Reflection, and Rapid Evolution of the Disk-Corona System," *The Astrophysical Journal*, 937: 8, 2022.
- Yim, Kijeong; Wong, Tony; Rand, Richard J. "The Volumetric Star Formation Law in the Almost Edge-on Galaxy NGC 4302 Revealed by the Atacama Large Millimeter/submillimeter Array," *The Astrophysical Journal*, 940: 118, 2022.
- Yoon, Ilsang "Spinning Nanoparticles Impacted by C-shock: Implications for Radio-millimeter Emission from Star-forming Regions," *The Astrophysical Journal*, 936: 179, 2022.
- Yoon, Sung-Yong; Herczeg, Gregory J.; Lee, Jeong-Eun; Lee, Ho-Gyu; Johnstone, Doug; Varricatt, Watson; Tobin, John J.; Contreras Peña, Carlos; Mairs, Steve; Hodapp, Klaus; Manoj, P.; Osorio, Mayra; Megeath, S. Thomas; Jcmt Transient Team "Dissecting the Different Components of the Modest Accretion Bursts of the Very Young Protostar HOPS 373," *The Astrophysical Journal*, 929: 60, 2022.
- Yoshida, Tomohiro C.; Nomura, Hideko; Furuya, Kenji; Tsukagoshi, Takashi; Lee, Seokho "A New Method for Direct Measurement of Isotopologue Ratios in Protoplanetary Disks: A Case Study of the 12CO/13CO Ratio in the TW Hya Disk," *The Astrophysical Journal*, 932: 126, 2022.
- Yoshida, Tomohiro C.; Nomura, Hideko; Tsukagoshi, Takashi; Furuya, Kenji; Ueda, Takahiro "Discovery of Line Pressure Broadening and Direct Constraint on Gas Surface Density in a Protoplanetary Disk," *The Astrophysical Journal*, 937: L14, 2022.
- Younes, George; Hu, Chin-Ping; Bansal, Karishma; Ray, Paul S.; Pearlman,



- Aaron B.; Kirsten, Franz; Wadiasingh, Zorawar; Göğüş, Ersin; Baring, Matthew G.; Enoto, Teruaki; Arzoumanian, Zaven; Gendreau, Keith C.; Kouveliotou, Chryssa; Güver, Tolga; Harding, Alice K.; Majid, Walid A.; Blumer, Harsha; Hessels, Jason W. T.; Gawronski, Marcin P.; Bezrukovs, Vladislavs; Orbicans, Arturs "X-Ray Burst and Persistent Emission Properties of the Magnetar SGR 1830-0645 in Outburst," *The Astrophysical Journal*, 924: 136, 2022.
- Young, Lisa M.; Meier, David S.; Crocker, Alison; Davis, Timothy A.; Topal, Selçuk "Down but Not Out: Properties of the Molecular Gas in the Stripped Virgo Cluster Early-type Galaxy NGC 4526," *The Astrophysical Journal*, 933: 90, 2022.
- Yu, Qingzheng; Fang, Taotao; Feng, Shuai; Zhang, Bo; Xu, C. Kevin; Wang, Yunting; Hao, Lei "On the H I Content of MaNGA Major Merger Pairs," *The Astrophysical Journal*, 934: 114, 2022.
- Yusef-Zadeh, F.; Arendt, R. G.; Wardle, M.; Boldyrev, S.; Heywood, I.; Cotton, W.; Camilo, F. "Statistical Properties of the Population of the Galactic Center Filaments II: The Spacing between Filaments," *Monthly Notices of the Royal Astronomical Society*, 515: 3059, 2022.
- Yusef-Zadeh, F.; Arendt, R. G.; Wardle, M.; Heywood, I.; Cotton, W. "The population of Galactic Centre filaments - III. Candidate radio and stellar sources," *Monthly Notices of the Royal Astronomical Society*, 517: 294, 2022.
- Yusef-Zadeh, F.; Arendt, R. G.; Wardle, M.; Heywood, I.; Cotton, W.; Camilo, F. "Statistical Properties of the Population of the Galactic Center Filaments: the Spectral Index and Equipartition Magnetic Field," *The Astrophysical Journal*, 925: L18, 2022.
- Zabel, Nikki; Brown, Toby; Wilson, Christine D.; Davis, Timothy A.; Cortese, Luca; Parker, Laura C.; Boselli, Alessandro; Catinella, Barbara; Chown, Ryan; Chung, Aeree; Deb, Tirna; Ellison, Sara L.; Jiménez-Donaire, María J.; Lee, Bumhyun; Roberts, Ian D.; Spekkens, Kristine; Stevens, Adam R. H.; Thorp, Mallory; Tonnesen, Stephanie; Villanueva, Vicente "VERTICO II: How H I-identified Environmental Mechanisms Affect the Molecular Gas in Cluster Galaxies," *The Astrophysical Journal*, 933: 10, 2022.
- Zabor, D.; Ryabov, M.; Sukharev, A.; Petrenko, M. "On the perspectives for separating the radio flux variations of the nucleus and the jet of active galactic based on data from monitoring programs and VLBI observations," *Astronomical and Astrophysical Transactions*, 33: 89, 2022.
- Zakri, Wafa; Megeath, S. T.; Fischer, William J.; Gutermuth, Robert; Furlan, Elise; Hartmann, Lee; Karnath, Nicole; Osorio, Mayra; Safron, Emily; Stanke, Thomas; Stutz, Amelia M.; Tobin, John J.; Allen, Thomas S.; Federman, Sam; Habel, Nolan; Manoj, P.; Narang, Mayank; Pokhrel, Riway; Rebull, Luisa; Sheehan, Patrick D.; Watson, Dan M. "The Rate, Amplitude, and Duration of Outbursts from Class 0 Protostars in Orion," *The Astrophysical Journal*, 924: L23, 2022.
- Zapata, Luis A.; Loinard, Laurent; Fernández-López, Manuel; Toalá, Jesús A.; González, Ricardo F.; Rodríguez, Luis F.; Gull, Theodore R.; Morris, Patrick W.; Menten, Karl M.; Kamiński, Tomasz "Catching the Butterfly and the Homunculus of  $\eta$  Carinae with ALMA," *The Astrophysical Journal*, 935: 76, 2022.
- Zavala, Jorge A.; Casey, Caitlin M.; Spilker, Justin; Tadaki, Ken-Ichi; Tsujita, Akiyoshi; Champagne, Jaclyn; Iono, Daisuke; Kohno, Kotaro; Manning, Sinclair; Montaña, Alfredo "Probing Cold Gas in a Massive, Compact Star-forming Galaxy at  $z = 6$ ," *The Astrophysical Journal*, 933: 242, 2022.
- Zdziarski, Andrzej A.; Tetarenko, Alexandra J.; Sikora, Marek "Jet Parameters in the Black Hole X-Ray Binary MAXI J1820+070," *The Astrophysical Journal*, 925: 189, 2022.
- Zhang, C.; Evans, Neal J.; Liu, T.; Wu, J.-W.; Wang, Ke; Liu, H.-L.; Zhu, F.-Y.; Ren, Z.-Y.; Dewangan, L. K.; Lee, Chang Won; Li, Shanghuo; Bronfman, L.; Tej, A.; Li, D. "ATOMS: ALMA Three-millimeter Observations of Massive Star-forming regions - IV. Radio recombination lines and evolution of star formation efficiencies," *Monthly Notices of the Royal Astronomical Society*, 510: 4998, 2022.
- Zhang, Fabao; Shu, Xinwen; Sun, Luming; Yang, Lei; Jiang, Ning; Dou, Liming; Wang, Jianguo; Wang, Tingui "Transient Radio Emission from Low-redshift Galaxies at  $z < 0.3$  Revealed by the VLASS and FIRST Surveys," *The Astrophysical Journal*, 938: 43, 2022.
- Zhang, Lei; Ridolfi, Alessandro; Blumer, Harsha; Freire, Paulo C. C.; Manchester, Richard N.; McLaughlin, Maura; Kremer, Kyle; Cameron, Andrew D.; Zhang, Zhiyu; Behrend, Jan; Burgay, Marta; Buchner, Sarah; Champion, David J.; Chen, Weiwei; Dai, Shi; Feng, Yi; Fu, Xiaoting; Guo, Meng; Hobbs, George; Keane, Evan F.; Kramer, Michael; Levin, Lina; Li, Xiangdong; Ni, Mengmeng; Pan, Jingshan; Padmanabh, Prajwal V.; Possenti, Andrea; Ransom, Scott M.; Tsai, Chao-Wei; Venkatraman Krishnan, Vivek; Wang, Pei; Zhang, Jie; Zhi, Qijun; Zhang, Yongkun; Li, Di "Radio Detection of an Elusive Millisecond Pulsar in the Globular Cluster NGC 6397," *The Astrophysical Journal*, 934: L21, 2022.
- Zhang, M.; Yuan, Q.; Liu, J.-Y.; Zhang, L. "Role of the companion lensing galaxy in the CLASS gravitational lens B1152+199," *Monthly Notices of the Royal Astronomical Society*, 511: 1085, 2022.
- Zhang, Y.; An, T.; Wang, A.; Frey, S.; Gurvits, L. I.; Gabányi, K. É.; Perger, K.; Paragi, Z. "VLBI observations of VIK J2318–3113, a quasar at  $z = 6.44$ ," *Astronomy and Astrophysics*, 662: L2, 2022.
- Zhang, Yichen; Tanaka, Kei E. I.; Tan, Jonathan C.; Yang, Yao-Lun; Greco, Eva; Beltran, Maria T.; Sakai, Nami; De Buizer, James M.; Rosero, Viviana; Fedriani, Rubén; Garay, Guido "Massive Protostars in a Protocluster - A Multi-scale ALMA View of G35.20-0.74N.," *The Astrophysical Journal*, 936: 68, 2022.
- Zhang, Yingkang; An, Tao; Frey, Sándor; Gabányi, Krisztina Éva; Sotnikova, Yulia "Radio Jet Proper-motion Analysis of Nine Distant Quasars above Redshift 3.5," *The Astrophysical Journal*, 937: 19, 2022.
- Zhang, Zhen; Jiang, Bin; Zhang, Yanxia "Automatic Detection and Classification of Radio Galaxy Images by Deep Learning," *Publications of the Astronomical Society of the Pacific*, 134: 064503, 2022.
- Zhao, Guang-Yao; Gómez, José L.; Fuentes, Antonio; Krichbaum, Thomas P.; Traianou, Efthalia; Lico, Rocco; Cho, Ilje; Ros, Eduardo; Komossa, S.; Akiyama, Kazunori; Asada, Keiichi; Blackburn, Lindy; Britzen, Silke; Bruni, Gabriele; Crew, Geoffrey B.; Dahale, Rohan; Dey, Lankeswar; Gold, Roman; Gopakumar, Achamveedu; Issaoun, Sara; Janssen, Michael; Jorstad, Svetlana; Kim, Jae-Young; Koay, Jun Yi; Kovalev, Yuri Y.; Koyama, Shoko; Lobanov, Andrei P.; Loinard, Laurent; Lu, Ru-Sen; Markoff, Sera; Marscher, Alan P.; Martí-Vidal, Iván; Mizuno, Yosuke; Park, Jongho; Savolainen, Tuomas; Toscano, Teresa "Unraveling the Innermost Jet Structure of OJ 287 with the First GMVA + ALMA Observations," *The Astrophysical Journal*, 932: 72, 2022.
- Zhao, Jun-Hui; Morris, Mark R.; Goss, W. M. "Detection of a Dense Group of Hypercompact Radio Sources in the Central Parsec of the Galaxy," *The Astrophysical Journal*, 927: L6, 2022.
- Zheng, X. C.; Röttgering, H. J. A.; Van Der Wel, A.; Duncan, K. "Shapes of galaxies hosting radio-loud AGNs with  $z \leq 1$ ," *Astronomy and Astrophysics*, 665: A114, 2022.
- Zheng, Yun; Wang, Jing; Irwin, Judith; Daniel Wang, Q.; Li, Jiangtao; English, Jayanne; Ma, Qingchuan; Wang, Ran; Wang, Ke; Krause, Marita; Randriamampandry, Toky H.; Beck, Rainer "H I Vertical Structure of Nearby Edge-on Galaxies from CHANG-ES," *Research in Astronomy and Astrophysics*, 22: 085004, 2022.
- Zheng, Yun; Wang, Jing; Irwin, Judith; English, Jayanne; Ma, Qingchuan; Wang, Ran; Wang, Ke; Wang, Q. Daniel; Krause, Marita; Randriamampandry, Toky H.; Li, Jiangtao; Beck, Rainer "CHANG-ES XXV: HI Imaging of Nearby Edge-on Galaxies - Data Release 4," *Monthly Notices of the Royal Astronomical Society*, 513: 1329, 2022.
- Zhou, Jian-Wen; Liu, Tie; Evans, Neal J.; Garay, Guido; Goldsmith, Paul F.; Gómez, Gilberto C.; Vázquez-Semadeni, Enrique; Liu, Hong-Li; Stutz, Amelia M.; Wang, Ke; Juvela, Mika; He, Jinhua; Li, Di; Bronfman, Leonardo; Liu, Xunchuan; Xu, Feng-Wei; Tej, Anandmayee; Dewangan, L. K.; Li, Shanghuo; Zhang, Sijun; Zhang, Chao; Ren, Zhiyuan; Tatematsu, Ken'Ichi; Shing Li, Pak; Won Lee, Chang; Baug, Tapas; Qin, Sheng-Li; Wu, Yuefang; Peng, Yaping; Zhang, Yong; Liu, Rong; Luo, Qiu-Yi; Ge,

## APPENDIX A: PUBLICATIONS

- Jixing; Saha, Anindya; Chakali, Eswaraiah; Zhang, Qizhou; Kim, Kee-Tae; Ristorcelli, Isabelle; Shen, Zhi-Qiang; Li, Jin-Zeng "ATOMS: ALMA Three-millimeter Observations of Massive Star-forming regions - XI. From inflow to infall in hub-filament systems," *Monthly Notices of the Royal Astronomical Society*, 514: 6038, 2022.
- Zhou, Jing; Zhang, Zhi-Yu; Gao, Yu; Wang, Junzhi; Shi, Yong; Gu, Qiusheng; Yang, Chentao; Wang, Tao; Tan, Qing-Hua "Dense Gas and Star Formation in Nearby Infrared-bright Galaxies: APEX Survey of HCN and HCO+ J = 2 → 1," *The Astrophysical Journal*, 936: 58, 2022.
- Zhou, Yipeng; Hao, Lei; Jiang, Peng; Pan, Xiang; Sun, Luming; Jin, Chichuan; Dai, Xuejie; Liu, Wenjuan; Ji, Tuo; Zheng, Zhenya; Huang, Xiangning; Shi, Xiheng; Wang, Yibo; Xiong, Yifei; Yang, Chenwei "Discovery of a Radio-loud Narrow-line Seyfert 1 Galaxy at  $z = 0.9$  Reddened with a Strong 2175 Å Bump," *The Astrophysical Journal*, 941: 111, 2022.
- Zhou, Yuren; Chen, Yanmei; Shi, Yong; Bizyaev, Dmitry; Guo, Hong; Bao, Min; Xu, Haitong; Yu, Xiaoling; Brownstein, Joel R. "SDSS-IV MaNGA: global properties of kinematically misaligned galaxies," *Monthly Notices of the Royal Astronomical Society*, 515: 5081, 2022.
- Zuo, Pei; Ho, Luis C.; Wang, Jing; Yu, Niankun; Shangguan, Jinyi "Massive Galaxy Mergers Have Distinctive Global H I Profiles," *The Astrophysical Journal*, 929: 15, 2022.



## 2023 NRAO REFEREED PUBLICATIONS

- Abbate, F.; Possenti, A.; Ridolfi, A.; Venkatraman Krishnan, V.; Buchner, S.; Barr, E. D.; Bailes, M.; Kramer, M.; Cameron, A.; Parthasarathy, A.; Van Straten, W.; Chen, W.; Camilo, F.; Padmanabh, P. V.; Mao, S. A.; Freire, P. C. C.; Ransom, S. M.; Vleeschower, L.; Geyer, M.; Zhang, L. "A MeerKAT look at the polarization of 47 Tucanae pulsars: magnetic field implications," *Monthly Notices of the Royal Astronomical Society*, 518, 1642, 2023.
- Abbate, F.; Ridolfi, A.; Freire, P. C. C.; Padmanabh, P. V.; Balakrishnan, V.; Buchner, S.; Zhang, L.; Kramer, M.; Stappers, B. W.; Barr, E. D.; Chen, W.; Champion, D.; Ransom, S.; Possenti, A. "A MeerKAT view of the pulsars in the globular cluster NGC 6522," *Astronomy and Astrophysics*, 680, A47, 2023.
- Abbott, R.; Abbott, T. D.; Acernese, F.; Ackley, K.; Adams, C.; Adhikari, N.; Adhikari, R. X.; Adya, V. B.; Affeldt, C.; Agarwal, D.; Agathos, M.; Agatsuma, K.; Aggarwal, N.; Aguiar, O. D.; Aiello, L.; Ain, A.; Ajith, P.; Akutsu, T.; Albanesi, S.; Allocca, A.; Altin, P. A.; Amato, A.; Anand, C.; Anand, S.; Ananyeva, A.; Anderson, S. B.; Anderson, W. G.; Ando, M.; Andrade, T.; Andres, N.; Andrić, T.; Angelova, S. V.; Ansoldi, S.; Antelis, J. M.; Antier, S.; Appert, S.; Arai, Koji; Arai, Koya; Arai, Y.; Araki, S.; Araya, A.; Araya, M. C.; Areeada, J. S.; Arène, M.; Aritomi, N.; Arnaud, N.; Aronson, S. M.; Arun, K. G.; Asada, H.; Asali, Y.; Ashton, G.; Aso, Y.; Assiduo, M.; Aston, S. M.; Astone, P.; Aubin, F.; Austin, C.; Babak, S.; Badaracco, F.; Bader, M. K. M.; Badger, C.; Bae, S.; Bae, Y.; Baer, A. M.; Bagnasco, S.; Bai, Y.; Baiotti, L.; Baird, J.; Bajpai, R.; Ball, M.; Ballardin, G.; Ballmer, S. W.; Balsamo, A.; Baltus, G.; Banagiri, S.; Bankar, D.; Barayoga, J. C.; Barbieri, C.; Barish, B. C.; Barker, D.; Barneo, P.; Barone, F.; Barr, B.; Barsotti, L.; Barsuglia, M.; Barta, D.; Bartlett, J.; Barton, M. A.; Bartos, I.; Bassiri, R.; Basti, A.; Bawaj, M.; Bayley, J. C.; Baylor, A. C.; Bazzan, M.; Bécsy, B.; Bedakihalé, V. M.; Beijer, M.; Belahcene, I.; Benedetto, V.; Beniwal, D.; Bennett, T. F.; Bentley, J. D.; Benyaala, M.; Bergamin, F.; Berger, B. K.; Bernuzzi, S.; Berry, C. P. L.; Bersanetti, D.; Bertolini, A.; Betzwieser, J.; Beveridge, D.; Bhandare, R.; Bhardwaj, U.; Bhattacharjee, D.; Bhaumik, S.; Bilenko, I. A.; Billingsley, G.; Bini, S.; Birney, R.; Birnholtz, O.; Biscans, S.; Bisch, M.; Biscoveanu, S.; Bisht, A.; Biswas, B.; Bitossi, M.; Bizouard, M.-A.; Blackburn, J. K.; Blair, C. D.; Blair, D. G.; Blair, R. M.; Bobba, F.; Bode, N.; Boer, M.; Bogaert, G.; Boldrini, M.; Bonavena, L. D.; Bondu, F.; Bonilla, E.; Bonnand, R.; Booker, P.; Boom, B. A.; Bork, R.; Boschi, V.; Bose, N.; Bose, S.; Bossilkov, V.; Boudart, V.; Bouffanais, Y.; Boumerdassi, A.; Bozzi, A.; Bradaschia, C.; Brady, P. R.; Bramley, A.; Branch, A.; Branchesi, M.; Brau, J. E.; Breschi, M.; Briant, T.; Briggs, J. H.; Brillet, A.; Brinkmann, M.; Brockill, P.; Brooks, A. F.; Brooks, J.; Brown, D. D.; Brunett, S.; Bruno, G.; Bruntz, R.; Bryant, J.; Buchanan, J.; Bulik, T.; Bulten, H. J.; Buonanno, A.; Buscicchio, R.; Buskulic, D.; Buy, C.; Byer, R. L.; Cadonati, L.; Cagnoli, G.; Cahillane, C.; Bustillo, J. Calderón; Callaghan, J. D.; Callister, T. A.; Calloni, E.; Cameron, J.; Camp, J. B.; Canepa, M.; Canevarolo, S.; Cannavacciuolo, M.; Cannon, K. C.; Cao, H.; Cao, Z.; Capocasa, E.; Capote, E.; Carapella, G.; Carbognani, F.; Carlin, J. B.; Carney, M. F.; Carpinelli, M.; Carrillo, G.; Carullo, G.; Carver, T. L.; Diaz, J. Casanueva; Casentini, C.; Castaldi, G.; Caudill, S.; Cavaglia, M.; Cavalier, F.; Cavaliere, R.; Ceasar, M.; Cella, G.; Cerdá-Durán, P.; Cesarini, E.; Chaibi, W.; Chakravarti, K.; Subrahmanya, S. Chalachadka; Champion, E.; Chan, C.-H.; Chan, C.; Chan, C. L.; Chan, K.; Chan, M.; Chandra, K.; Chantial, P.; Chao, S.; Charlton, P.; Chase, E. A.; Chassande-Mottin, E.; Chatterjee, C.; Chatterjee, Debarati; Chatterjee, Deep; Chaturvedi, M.; Chaty, S.; Chen, C.; Chen, H. Y.; Chen, J.; Chen, K.; Chen, X.; Chen, Y.-B.; Chen, Y.-R.; Chen, Z.; Cheng, H.; Cheong, C. K.; Cheung, H. Y.; Chia, H. Y.; Chiadini, F.; Chiang, C.-Y.; Chiarini, G.; Chierici, R.; Chincarini, A.; Chiofalo, M. L.; Chiummo, A.; Cho, G.; Cho, H. S.; Choudhary, R. K.; Choudhary, S.; Christensen, N.; Chu, H.; Chu, Q.; Chu, Y.-K.; Chua, S.; Chung, K. W.; Ciani, G.; Ciocielag, P.; Cieřlar, M.; Cifaldi, M.; Ciobanu, A. A.; Ciolfi, R.; Cipriano, F.; Cirone, A.; Clara, F.; Clark, E. N.; Clark, J. A.; Clarke, L.; Clearwater, P.; Clesse, S.; Cleva, F.; Coccia, E.; Codazzo, E.; Cohadon, P.-F.; Cohen, D. E.; Cohen, L.; Colleoni, M.; Collette, C. G.; Colombo, A.; Colpi, M.; Compton, C. M.; Constanancio, M., Jr.; Conti, L.; Cooper, S. J.; Corban, P.; Corbitt, T. R.; Cordero-Carrión, I.; Corezzi, S.; Corley, K. R.; Cornish, N.; Corre, D.; Corsi, A.; Cortese, S.; Costa, C. A.; Cotesta, R.; Coughlin, M. W.; Coulon, J.-P.; Countryman, S. T.; Cousins, B.; Couvares, P.; Coward, D. M.; Cowart, M. J.; Coyne, D. C.; Coyne, R.; Creighton, J. D. E.; Creighton, T. D.; Criswell, A. W.; Croquette, M.; Crowder, S. G.; Cudell, J. R.; Cullen, T. J.; Cumming, A.; Cummings, R.; Cunningham, L.; Cuoco, E.; Curyło, M.; Dabadie, P.; Dal Canton, T.; Dall'Osso, S.; Dálya, G.; Dana, A.; Daneshgaranbajastani, L. M.; D'Angelo, B.; Danilishin, S.; D'Antonio, S.; Danzmann, K.; Darsow-Fromm, C.; Dasgupta, A.; Datriel, L. E. H.; Datta, S.; Dattilo, V.; Dave, I.; Davier, M.; Davies, G. S.; Davis, D.; Davis, M. C.; Daw, E. J.; Dean, R.; Debra, D.; Deenadayalan, M.; Degallaix, J.; De Laurentis, M.; Deléglise, S.; Del Favero, V.; De Lillo, F.; De Lillo, N.; Del Pozzo, W.; Demarchi, L. M.; De Matteis, F.; D'Emilio, V.; Demos, N.; Dent, T.; Depasse, A.; De Pietri, R.; De Rosa, R.; De Rossi, C.; Desalvo, R.; De Simone, R.; Dhurandhar, S.; Díaz, M. C.; Diaz-Ortiz, M., Jr.; Didio, N. A.; Dietrich, T.; Di Fiore, L.; Di Fronzo, C.; Di Giorgio, C.; Di Giovanni, F.; Di Giovanni, M.; Di Girolamo, T.; Di Lieto, A.; Ding, B.; Di Pace, S.; Di Palma, I.; Di Renzo, F.; Divakarla, A. K.; Dmitriev, A.; Doctor, Z.; D'Onofrio, L.; Donovan, F.; Dooley, K. L.; Doravari, S.; Dorrington, I.; Drago, M.; Driggers, P. C.; Drori, Y.; Ducoin, J.-G.; Dupej, P.; Durante, O.; D'Urso, D.; Duverne, J.-A.; Dwyer, S. E.; Eassa, C.; Easter, P. J.; Ebersold, M.; Eckhardt, T.; Eddolls, G.; Edelman, B.; Edo, T. B.; Edy, O.; Effler, A.; Eguchi, S.; Eichholz, J.; Eikenberry, S. S.; Eisenmann, M.; Eisenstein, R. A.; Ejlli, A.; Engelby, E.; Enomoto, Y.; Errico, L.; Essick, R. C.; Estellés, H.; Estevez, D.; Etienne, Z.; Etzel, T.; Evans, M.; Evans, T. M.; Ewing, B. E.; Fafone, V.; Fair, H.; Fairhurst, S.; Farah, A. M.; Farinon, S.; Farr, B.; Farr, W. M.; Farrow, N. W.; Fauchon-Jones, E. J.; Favaro, G.; Favata, M.; Fays, M.; Fazio, M.; Feicht, J.; Fejer, M. M.; Fenyvesi, E.; Ferguson, D. L.; Fernandez-Galiana, A.; Ferrante, I.; Ferreira, T. A.; Fidecaro, F.; Figura, P.; Fiori, I.; Fishbach, M.; Fisher, R. P.; Fittipaldi, R.; Fiumara, V.; Flaminio, R.; Floden, E.; Fong, H.; Font, J. A.; Fornal, B.; Forsyth, P. W. F.; Franke, A.; Frasca, S.; Frasconi, F.; Frederick, C.; Freed, J. P.; Frei, Z.; Freise, A.; Frey, R.; Fritschel, P.; Frolov, V. V.; Fronzé, G. G.; Fujii, Y.; Fujikawa, Y.; Fukunaga, M.; Fukushima, M.; Fulda, P.; Fyffe, M.; Gabbard, H. A.; Gadre, B. U.; Gair, J. R.; Gais, J.; Galadage, S.; Gamba, R.; Ganapathy, D.; Ganguly, A.; Gao, D.; Gaonkar, S. G.; Garaventa, B.; García-Núñez, C.; García-Quirós, C.; Garufi, F.; Gateley, B.; Gaudio, S.; Gayathri, V.; Ge, G.-G.; Gemme, G.; Gennai, A.; George, J.; Gerberding, O.; Gergely, L.; Gewecke, P.; Ghonge, S.; Ghosh, Abhirup; Ghosh, Archisman; Ghosh, Shaon; Ghosh, Shrobona; Giacomazzo, B.; Giaccoppo, L.; Giaime, J. A.; Giardina, K. D.; Gibson, D. R.; Gier, C.; Giesler, M.; Giri, P.; Gissi, F.; Glanzer, J.; Gleckl, A. E.; Godwin, P.; Goetz, E.; Goetz, R.; Gohlke, N.; Goncharov, B.; González, G.; Gopakumar, A.; Gosselin, M.; Gouaty, R.; Gould, D. W.; Grace, B.; Grado, A.; Granata, M.; Granata, V.; Grant, A.; Gras, S.; Grassia, P.; Gray, C.; Gray, R.; Greco, G.; Green, A. C.; Green, R.; Gretarsson, A. M.; Gretarsson, E. M.; Griffith, D.; Griffiths, W.; Griggs, H. L.; Grignani, G.; Grimaldi, A.; Grimm, S. J.; Grote, H.; Grunewald, S.; Gruning, P.; Guerra, D.; Guidi, G. M.; Guimaraes, A. R.; Guixé, G.; Gulati, H. K.; Guo, H.-K.; Guo, Y.; Gupta, Anchal; Gupta, Anuradha; Gupta, P.; Gustafson, E. K.; Gustafson, R.; Guzman, F.; Ha, S.; Haegel, L.; Hagiwara, A.; Haino, S.; Halim, O.; Hall, E. D.; Hamilton, E. Z.; Hammond, G.; Han, W.-B.; Haney, M.; Hanks, J.; Hanna, C.; Hannam, M. D.; Hannuksela, O.; Hansen, H.; Hansen, T. J.; Hanson, J.; Harder, T.; Hardwick, T.; Haris, K.; Harms, J.; Harry, G. M.; Harry, I. W.; Hartwig, D.; Hasegawa, K.; Haskell, B.; Hasskew, R. K.; Haster, C.-J.; Hattori, K.; Haughian, K.; Hayakawa, H.;

Hayama, K.; Hayes, F. J.; Healy, J.; Heidmann, A.; Heidt, A.; Heintze, M. C.; Heinze, J.; Heinzel, J.; Heitmann, H.; Hellman, F.; Hello, P.; Helmling-Cornell, A. F.; Hemming, G.; Hendry, M.; Heng, I. S.; Hennes, E.; Hennig, J.; Hennig, M. H.; Hernandez, A. G.; Hernandez Vivanco, F.; Heurs, M.; Hild, S.; Hill, P.; Himemoto, Y.; Hines, A. S.; Hiranuma, Y.; Hirata, N.; Hirose, E.; Hochheim, S.; Hofman, D.; Hohmann, J. N.; Holcomb, D. G.; Holland, N. A.; Hollows, I. J.; Holmes, Z. J.; Holt, K.; Holz, D. E.; Hong, Z.; Hopkins, P.; Hough, J.; Hourihane, S.; Howell, E. J.; Hoy, C. G.; Hoyland, D.; Hreibi, A.; Hsieh, B.-H.; Hsu, Y.; Huang, G.-Z.; Huang, H.-Y.; Huang, P.; Huang, Y.-C.; Huang, Y.-J.; Huang, Y.; Hübner, M. T.; Huddart, A. D.; Hughey, B.; Hui, D. C. Y.; Hui, V.; Husa, S.; Huttner, S. H.; Huxford, R.; Huynh-Dinh, T.; Ide, S.; Idzkowski, B.; Iess, A.; Ikenoue, B.; Imam, S.; Inayoshi, K.; Ingram, C.; Inoue, Y.; Ioka, K.; Isi, M.; Isleif, K.; Ito, K.; Itoh, Y.; Iyer, B. R.; Izumi, K.; Jaberianhamedan, V.; Jacqmin, T.; Jadhav, S. J.; Jadhav, S. P.; James, A. L.; Jan, A. Z.; Jani, K.; Janquart, J.; Janssens, K.; Janthalur, N. N.; Jaranowski, P.; Jariwala, D.; Jaume, R.; Jenkins, A. C.; Jenner, K.; Jeon, C.; Jeunon, M.; Jia, W.; Jin, H.-B.; Johns, G. R.; Jones, A. W.; Jones, D. I.; Jones, J. D.; Jones, P.; Jones, R.; Jonker, R. J. G.; Ju, L.; Jung, P.; Jung, K.; Junker, J.; Juste, V.; Kaihotsu, K.; Kajita, T.; Kakizaki, M.; Kalaghatgi, C. V.; Kalogera, V.; Kamai, B.; Kamiizumi, M.; Kanda, N.; Kandhasamy, S.; Kang, G.; Kanner, J. B.; Kao, Y.; Kapadia, S. J.; Kapasi, D. P.; Karat, S.; Karathanasis, C.; Karki, S.; Kashyap, R.; Kasprack, M.; Kastau, W.; Katsanevas, S.; Katsavounidis, E.; Katzman, W.; Kaur, T.; Kawabe, K.; Kawaguchi, K.; Kawai, N.; Kawasaki, T.; Kéfélian, F.; Keitel, D.; Key, J. S.; Khadka, S.; Khalili, F. Y.; Khan, S.; Khazanov, E. A.; Khetan, N.; Khursheed, M.; Kijbunchoo, N.; Kim, C.; Kim, J. C.; Kim, J.; Kim, K.; Kim, W. S.; Kim, Y.-M.; Kimball, C.; Kimura, N.; Kinley-Hanlon, M.; Kirchhoff, R.; Kissel, J. S.; Kita, N.; Kitazawa, H.; Kleybolte, L.; Klimenko, S.; Knee, A. M.; Knowles, T. D.; Knyazev, E.; Koch, P.; Koekoek, G.; Kojima, Y.; Kokeyama, K.; Koley, S.; Kolitsidou, P.; Kolstein, M.; Komori, K.; Kondrashov, V.; Kong, A. K. H.; Kontos, A.; Koper, N.; Korobko, M.; Kotake, K.; Kovalam, M.; Kozak, D. B.; Kozakai, C.; Kozu, R.; Kringel, V.; Krishnendu, N. V.; Królak, A.; Kuehn, G.; Kuei, F.; Kuijjer, P.; Kumar, A.; Kumar, P.; Kumar, Rahul; Kumar, Rakesh; Kume, J.; Kuns, K.; Kuo, C.; Kuo, H.-S.; Kuromiya, Y.; Kuroyanagi, S.; Kusayanagi, K.; Kuwahara, S.; Kwak, K.; Lagabbe, P.; Laghi, D.; Lalande, E.; Lam, T. L.; Lamberts, A.; Landry, M.; Lane, B. B.; Lang, R. N.; Lange, J.; Lantz, B.; La Rosa, I.; Lartaux-Vollard, A.; Lasky, P. D.; Laxen, M.; Lazzarini, A.; Lazzaro, C.; Leaci, P.; Leavey, S.; Leconte, Y. K.; Lee, H. K.; Lee, H. M.; Lee, H. W.; Lee, J.; Lee, K.; Lee, R.; Lehmann, J.; Lemaître, A.; Leonardi, M.; Leroy, N.; Letendre, N.; Levesque, C.; Levin, Y.; Leviton, J. N.; Leyde, K.; Li, A. K. Y.; Li, B.; Li, J.; Li, K. L.; Li, T. G. F.; Li, X.; Lin, C.-Y.; Lin, F.-K.; Lin, F.-L.; Lin, H. L.; Lin, L. C.-C.; Linde, F.; Linker, S. D.; Linley, J. N.; Littenberg, T. B.; Liu, G. C.; Liu, J.; Liu, K.; Liu, X.; Llamas, F.; Llorens-Monteagudo, M.; Lo, R. K. L.; Lockwood, A.; London, L. T.; Longo, A.; Lopez, D.; Lopez Portilla, M.; Lorenzini, M.; Lorette, V.; Lormand, M.; Losurdo, G.; Lott, T. P.; Lough, J. D.; Lousto, C. O.; Lovelace, G.; Lucaccioni, J. F.; Lück, H.; Lumaca, D.; Lundgren, A. P.; Luo, L.-W.; Lynam, J. E.; Macas, R.; Macinnis, M.; Macleod, D. M.; Macmillan, I. A. O.; Macquet, A.; Hernandez, I. Magaña; Magazzù, C.; Magee, R. M.; Maggiore, R.; Magnozzi, M.; Mahesh, S.; Majorana, E.; Makarem, C.; Maksimovic, I.; Maliakal, S.; Malik, A.; Man, N.; Mandic, V.; Mangano, V.; Mango, J. L.; Mansell, G. L.; Manske, M.; Mantovani, M.; Mapelli, M.; Marchesoni, F.; Marchio, M.; Marion, F.; Mark, Z.; Márka, S.; Márka, Z.; Markakis, C.; Markosyan, A. S.; Markowitz, A.; Maros, E.; Marquina, A.; Marsat, S.; Martelli, F.; Martin, I. W.; Martin, R. M.; Martinez, M.; Martinez, V. A.; Martinez, V.; Martinovic, K.; Martynov, D. V.; Marx, E. J.; Masalehdan, H.; Mason, K.; Massera, E.; Masserot, A.; Massinger, T. J.; Masso-Reid, M.; Mastrogiovanni, S.; Matas, A.; Mateu-Lucena, M.; Matchard, F.; Matiushechikina, M.; Mavalvala, N.; Mccann, J. J.; Mccarthy, R.; Mcclelland, D. E.; Mcclellin, P. K.; Mccormick, S.; Mcculler, L.; Mcghee, G. I.; Mcguire, S. C.; Mccisaac, C.; Mciver, J.; Mccrae, T.; Mcwilliams, S. T.; Meacher, D.; Mehmet, M.; Mehta, A. K.; Meijer, O.; Melatos, A.; Melchor, D. A.; Mendell, G.; Menendez-Vazquez, A.; Menoni, C. S.; Mercer, R. A.; Mereni, L.; Merfeld, K.; Merill, E. L.; Merritt, J. D.; Merzougui, M.; Meshkov, S.; Messenger, C.; Messick, C.; Meyers, P. M.; Meylahn, F.; Mhaske, A.; Miani, A.; Miao, H.; Michaloliakos, I.; Michel, C.; Michimura, Y.; Middleton, H.; Milano, L.; Miller, A. L.; Miller, A.; Miller, B.; Millhouse, M.; Mills, J. C.; Milotti, E.; Minazzoli, O.; Minenkov, Y.; Mio, N.; Mir, L. M.; Miravet-Tenés, M.; Mishra, C.; Mishra, T.; Mistry, T.; Mitra, S.; Mitrofanov, V. P.; Mitselmakher, G.; Mittleman, R.; Miyakawa, O.; Miyamoto, A.; Miyazaki, Y.; Miyo, K.; Miyoki, S.; Mo, Geoffrey; Moguel, E.; Mogushi, K.; Mohapatra, S. R. P.; Mohite, S. R.; Molina, I.; Molina-Ruiz, M.; Mondin, M.; Montani, M.; Moore, C. J.; Moraru, D.; Morawski, F.; More, A.; Moreno, C.; Moreno, G.; Mori, Y.; Morisaki, S.; Moriwaki, Y.; Mours, B.; Mow-Lowry, C. M.; Mozzon, S.; Muciaccia, F.; Mukherjee, Arunava; Mukherjee, D.; Mukherjee, Soma; Mukherjee, Subroto; Mukherjee, Suvodip; Mukund, N.; Mullavey, A.; Munch, J.; Muñiz, E. A.; Murray, P. G.; Musenich, R.; Muusse, S.; Nadjji, S. L.; Nagano, K.; Nagano, S.; Nagar, A.; Nakamura, K.; Nakano, H.; Nakano, M.; Nakashima, R.; Nakayama, Y.; Napolano, V.; Nardecchia, I.; Narikawa, T.; Naticchioni, L.; Nayak, B.; Nayak, R. K.; Negishi, R.; Neil, B. F.; Neilson, J.; Nelemans, G.; Nelson, T. J. N.; Nery, M.; Neubauer, P.; Neunzert, A.; Ng, K. Y.; Ng, S. W. S.; Nguyen, C.; Nguyen, P.; Nguyen, T.; Quynh, L. Nguyen; Ni, W.-T.; Nichols, S. A.; Nishizawa, A.; Nissanke, S.; Nitoglia, E.; Nocera, F.; Norman, M.; North, C.; Nozaki, S.; Nuttall, L. K.; Oberling, J.; O'Brien, B. D.; Obuchi, Y.; O'Dell, J.; Oelker, E.; Ogaki, Y.; Oganessian, G.; Oh, J. J.; Oh, K.; Oh, S. H.; Ohashi, M.; Ohishi, N.; Ohkawa, M.; Ohme, F.; Ohta, H.; Okada, M. A.; Okutani, Y.; Okutomi, K.; Olivetto, C.; Oohara, K.; Ooi, C.; Oram, R.; O'Reilly, B.; Ormiston, R. G.; Ormsby, N. D.; Ortega, L. F.; O'Shaughnessy, R.; O'Shea, E.; Oshino, S.; Ossokine, S.; Osthelder, C.; Otabe, S.; Ottaway, D. J.; Overmier, H.; Pace, A. E.; Pagano, G.; Page, M. A.; Pagliaroli, G.; Pai, A.; Pai, S. A.; Palamos, J. R.; Palashov, O.; Palomba, C.; Pan, H.; Pan, K.; Panda, P. K.; Pang, H.; Pang, P. T. H.; Pankow, C.; Pannarale, F.; Pant, B. C.; Panther, F. H.; Paoletti, F.; Paoli, A.; Paolone, A.; Parisi, A.; Park, H.; Park, J.; Parker, W.; Pascucci, D.; Pasqualetti, A.; Passaquieti, R.; Passuello, D.; Patel, M.; Pathak, M.; Patricelli, B.; Patron, A. S.; Patrone, S.; Paul, S.; Payne, E.; Pedraza, M.; Pegoraro, M.; Pele, A.; Arellano, F. E. Peña; Penn, S.; Perego, A.; Pereira, A.; Pereira, T.; Perez, C. J.; Périgois, C.; Perkins, C. C.; Perreca, A.; Perriès, S.; Petermann, J.; Petterson, D.; Pfeiffer, H. P.; Pham, K. A.; Phukon, K. S.; Piccinni, O. J.; Pichot, M.; Piendibene, M.; Piergiovanni, F.; Pierini, L.; Piarro, V.; Pillant, G.; Pillas, M.; Pilo, F.; Pinard, L.; Pinto, I. M.; Pinto, M.; Piotrkowski, B. J.; Piotrkowski, K.; Pirello, M.; Pitkin, M. D.; Placidi, E.; Planas, L.; Plastino, W.; Pluchar, C.; Poggiani, R.; Polini, E.; Pong, D. Y. T.; Ponrathnam, S.; Popolizio, P.; Porter, E. K.; Poulton, R.; Powell, J.; Pracchia, M.; Pradier, T.; Prajapati, A. K.; Prasai, K.; Prasanna, R.; Pratten, G.; Principe, M.; Prodi, G. A.; Prokhorov, L.; Prosperto, P.; Prudenzi, J.; Puecher, A.; Punturo, M.; Puosi, F.; Puppo, P.; Pürrer, M.; Qi, H.; Quetschke, V.; Quitzow-James, R.; Raab, F. J.; Raaijmakers, G.; Radkins, H.; Radulesco, N.; Raffai, P.; Rail, S. X.; Raja, S.; Rajan, C.; Ramirez, K. E.; Ramirez, T. D.; Ramos-Buades, A.; Rana, J.; Rapagnani, P.; Rapol, U. D.; Ray, A.; Raymond, V.; Raza, N.; Razzano, M.; Read, J.; Rees, L. A.; Regimbau, T.; Rei, L.; Reid, S.; Reid, S. W.; Reitze, D. H.; Relton, P.; Renzini, A.; Rettegno, P.; Rezac, M.; Ricci, F.; Richards, D.; Richardson, J. W.; Richardson, L.; Riemenschneider, G.; Riles, K.; Rinaldi, S.; Rink, K.; Rizzo, M.; Robertson, N. A.; Robie, R.; Robinet, F.; Rocchi, A.; Rodriguez, S.; Rolland, L.; Rollins, J. G.; Romanelli, M.; Romano, R.; Romel, C. L.; Romero-Rodríguez, A.; Romero-Shaw, I. M.; Romio, J. H.; Ronchini, S.; Rosa, L.; Rose, C. A.; Rosińska, D.; Ross, M. P.; Rowan, S.; Rowlinson, S. J.; Roy, S.; Roy, Santosh; Roy, Soumen; Rozza, D.; Ruggi, P.; Ryan, K.; Sachdev, S.; Sadecki, T.; Sadiq, J.; Sago, N.; Saito, S.; Saito, Y.; Sakai, K.; Sakai, Y.; Sakellariadou, M.; Sakuno, Y.; Salafia, O. S.; Salconi, L.; Saleem, M.; Salemi, F.; Samajdar, A.; Sanchez, E. J.; Sanchez, J. H.; Sanchez, L. E.; Sanchis-Gual, N.; Sanders, J. R.; Sanuy, A.; Saravanan, T. R.; Sarin, N.; Sassolas, B.; Satari, H.; Sato, S.; Sato, T.; Sauter, O.; Savage, R. L.; Sawada, T.; Sawant, D.; Sawant, H. L.; Sayah, S.; Schaetzel, D.; Scheel, M.; Scheuer, J.; Schiworski, M.; Schmidt, P.; Schmidt, S.; Schnabel, R.; Schneewind, M.; Schofield, R. M. S.; Schönbeck, A.

## APPENDIX A: PUBLICATIONS

- Schulte, B. W.; Schutz, B. F.; Schwartz, E.; Scott, J.; Scott, S. M.; Seglar-Arroyo, M.; Sekiguchi, T.; Sekiguchi, Y.; Sellers, D.; Sengupta, A. S.; Sentenac, D.; Seo, E. G.; Sequino, V.; Sergeev, A.; Setyawati, Y.; Shaffer, T.; Shahriar, M. S.; Shams, B.; Shao, L.; Sharma, A.; Sharma, P.; Shawhan, P.; Shchepanov, N. S.; Shibagaki, S.; Shikachi, M.; Shimizu, R.; Shimoda, T.; Shimode, K.; Shinkai, H.; Shishido, T.; Shoda, A.; Shoemaker, D. H.; Shoemaker, D. M.; Shyamsundar, S.; Sieniawska, M.; Sigg, D.; Singer, L. P.; Singh, D.; Singh, N.; Singha, A.; Sintés, A. M.; Sipala, V.; Skliris, V.; Slagmolen, B. J. J.; Slaven-Blair, T. J.; Smetana, J.; Smith, J. R.; Smith, R. J. E.; Soldateschi, J.; Somala, S. N.; Somiya, K.; Son, E. J.; Soni, K.; Soni, S.; Sordini, V.; Sorrentino, F.; Sorrentino, N.; Sotani, H.; Soullard, R.; Souradeep, T.; Sowell, E.; Spagnuolo, V.; Spencer, A. P.; Spera, M.; Srinivasan, R.; Srivastava, A. K.; Srivastava, V.; Staats, K.; Stachie, C.; Steer, D. A.; Steinlechner, J.; Steinlechner, S.; Stops, D. J.; Stover, M.; Strain, K. A.; Strang, L. C.; Stratta, G.; Strunk, A.; Sturani, R.; Stuver, A. L.; Sudhagar, S.; Sudhir, V.; Sugimoto, R.; Suh, H. G.; Summerscales, T. Z.; Sun, H.; Sun, L.; Sunil, S.; Sur, A.; Suresh, J.; Sutton, P. J.; Suzuki, Takamasu; Suzuki, Toshikazu; Swinkels, B. L.; Szczepańczyk, M. J.; Szewczyk, P.; Tacca, M.; Tagoshi, H.; Tait, S. C.; Takahashi, H.; Takahashi, R.; Takamori, A.; Takano, S.; Takeda, H.; Takeda, M.; Talbot, C. J.; Talbot, C.; Tanaka, H.; Tanaka, Kazuyuki; Tanaka, Kenta; Tanaka, Taiki; Tanaka, Takahiro; Tanasijczuk, A. J.; Tanioka, S.; Tanner, D. B.; Tao, D.; Tao, L.; San Martín, E. N. Tapia; San Martín, E. N. Tapia; Taranto, C.; Tasson, J. D.; Telada, S.; Tenorio, R.; Terhune, J. E.; Terkowski, L.; Thirugnanasambandam, M. P.; Thomas, M.; Thomas, P.; Thompson, J. E.; Thondapu, S. R.; Thorne, K. A.; Thrane, E.; Tiwari, Shubhanshu; Tiwari, Srishti; Tiwari, V.; Toivonen, A. M.; Toland, K.; Tolley, A. E.; Tomaru, T.; Tomigami, Y.; Tomura, T.; Tonelli, M.; Torres-Forné, A.; Torrie, C. I.; E Melo, I. Tosta; Töyrä, D.; Trapananti, A.; Travasso, F.; Traylor, G.; Trevor, M.; Tringali, M. C.; Tripathy, A.; Troiano, L.; Trovato, A.; Trozzo, L.; Trudeau, R. J.; Tsai, D. S.; Tsai, D.; Tsang, K. W.; Tsang, T.; Tsao, J.-S.; Tse, M.; Tso, R.; Tsubono, K.; Tsuchida, S.; Tsukada, L.; Tsuna, D.; Tsutsui, T.; Tsuzuki, T.; Turbang, K.; Turconi, M.; Tuyenbayev, D.; Ubhi, A. S.; Uchikata, N.; Uchiyama, T.; Udall, R. P.; Ueda, A.; Uehara, T.; Ueno, K.; Ueshima, G.; Unnikrishnan, C. S.; Uraguchi, F.; Urban, A. L.; Ushiba, T.; Utina, A.; Vahlbruch, H.; Vajente, G.; Vajpeyi, A.; Valdes, G.; Valentini, M.; Valsan, V.; Van Bakel, N.; Van Beuzekom, M.; Brand, J. F. J. Van Den; Broeck, C. Van Den; VanderHyde, D. C.; Van Der Schaaf, L.; Van Heijningen, J. V.; Vanosky, J.; Putten, M. H. P. M. Van; Van Remortel, N.; Vardaro, M.; Vargas, A. F.; Varma, V.; Vasúth, M.; Vecchio, A.; Vedovato, G.; Veitch, J.; Veitch, P. J.; Venneberg, J.; Venugopalan, G.; Verkindt, D.; Verma, P.; Verma, Y.; Veske, D.; Vetrano, F.; Viceré, A.; Vidyant, S.; Viets, A. D.; Vijaykumar, A.; Villa-Ortega, V.; Vinet, J.-Y.; Virtuoso, A.; Vitale, S.; Vo, T.; Vocca, H.; Von Reis, E. R. G.; Von Wrangel, J. S. A.; Vorvick, C.; Vyatchanin, S. P.; Wade, L. E.; Wade, M.; Wagner, K. J.; Walet, R. C.; Walker, M.; Wallace, G. S.; Wallace, L.; Walsh, S.; Wang, J.; Wang, J. Z.; Wang, W. H.; Ward, R. L.; Warner, J.; Was, M.; Washimi, T.; Washington, N. Y.; Watada, K.; Watchi, J.; Weaver, B.; Webster, S. A.; Weinert, M.; Weinstein, A. J.; Weiss, R.; Weller, C. M.; Wellmann, F.; Wen, L.; Weßels, P.; Wette, K.; Whelan, J. T.; White, D. D.; Whiting, B. F.; Whittle, C.; Wilken, D.; Williams, D.; Williams, M. J.; Williamson, A. R.; Willis, J. L.; Willke, B.; Wilson, D. J.; Winkler, W.; Wipf, C. C.; Wlodarczyk, T.; Woan, G.; Woehler, J.; Wofford, J. K.; Wong, I. C. F.; Wu, C.; Wu, D. S.; Wu, H.; Wu, S.; Wysocki, D. M.; Xiao, L.; Xu, W.-R.; Yamada, T.; Yamamoto, H.; Yamamoto, Kazuhiro; Yamamoto, Kohei; Yamamoto, T.; Yamashita, K.; Yamazaki, R.; Yang, F. W.; Yang, L.; Yang, Y.; Yang, Yang; Yang, Z.; Yap, M. J.; Yeeles, D. W.; Yelikar, A. B.; Ying, M.; Yokogawa, K.; Yokoyama, J.; Yokozawa, T.; Yoo, J.; Yoshioka, T.; Yu, Hang; Yu, Haocun; Yuzurihara, H.; Zadrożny, A.; Zanolin, M.; Zeidler, S.; Zelenova, T.; Zendri, J.-P.; Zevin, M.; Zhan, M.; Zhang, H.; Zhang, J.; Zhang, L.; Zhang, T.; Zhang, Y.; Zhao, C.; Zhao, G.; Zhao, Y.; Zhao, Yue; Zhou, R.; Zhou, Z.; Zhu, X. J.; Zhu, Z.-H.; Zimmerman, A. B.; Zucker, M. E.; Zweizig, J.; Bhardwaj, M.; Boyle, P. J.; Cassanelli, T.; Dong, F.; Fonseca, E.; Kaspi, V.; Leung, C.; Masui, K. W.; Meyers, B. W.; Michilli, D.; Ng, C.; Pearlman, A. B.; Petroff, E.; Pleunis, Z.; Rafiei-Ravandi, M.; Rahman, M.; Ransom, S.; Scholz, P.; Shin, K.; Smith, K.; Stairs, I.; Tendulkar, S. P.; Zwaniga, A. V.; Chime/Frb Collaboration "Search for Gravitational Waves Associated with Fast Radio Bursts Detected by CHIME/FRB during the LIGO-Virgo Observing Run O3a," *The Astrophysical Journal*, 955, 155, 2023.
- Abe, H.; Abe, S.; Acciari, V. A.; Agudo, I.; Aniello, T.; Ansoldi, S.; Antonelli, L. A.; Arbet-Engels, A.; Arcaro, C.; Artero, M.; Asano, K.; Baack, D.; Babić, A.; Baquero, A.; Barres De Almeida, U.; Barrio, J. A.; Batković, I.; Baxter, J.; Becerra González, J.; Bednarek, W.; Bernardini, E.; Bernardos, M.; Bertl, A.; Besenrieder, J.; Bhattacharyya, W.; Bigongiari, C.; Biland, A.; Blanch, O.; Bonnoli, G.; Bošnjak, Ž.; Burelli, I.; Busetto, G.; Carosi, R.; Carretero-Castrillo, M.; Castro-Tirado, A. J.; Ceribella, G.; Chai, Y.; Chilingarian, A.; Cikota, S.; Colombo, E.; Contreras, J. L.; Cortina, J.; Covino, S.; D'Amico, G.; D'Elia, V.; Da Vela, P.; Dazzi, F.; De Angelis, A.; De Lotto, B.; Del Popolo, A.; Delfino, M.; Delgado, J.; Delgado Mendez, C.; Depaoli, D.; Di Pierro, F.; Di Venere, L.; Do Souto Espiñeira, E.; Dominis Prester, D.; Donini, A.; Dorner, D.; Doro, M.; Elsaesser, D.; Emery, G.; Escudero, J.; Fallah Ramazani, V.; Fariña, L.; Fattorini, A.; Foffano, L.; Font, L.; Fruck, C.; Fukami, S.; Fukazawa, Y.; García López, R. J.; Garczarczyk, M.; Gasparyan, S.; Gaug, M.; Giesbrecht Paiva, J. G.; Giglietto, N.; Giordano, F.; Gliwny, P.; Godinović, N.; Grau, R.; Green, D.; Green, J. G.; Hadasch, D.; Hahn, A.; Hassan, T.; Heckmann, L.; Herrera, J.; Hrupec, D.; Hütten, M.; Imazawa, R.; Inada, T.; Iotov, R.; Ishio, K.; Jiménez Martínez, I.; Jormanainen, J.; Kerszberg, D.; Kobayashi, Y.; Kubo, H.; Kushida, J.; Lamastra, A.; Lelas, D.; Leone, F.; Lindfors, E.; Linhoff, L.; Lombardi, S.; Longo, F.; López-Coto, R.; López-Moya, M.; López-Oramas, A.; Loporchio, S.; Lorini, A.; Lyard, E.; Machado De Oliveira Fraga, B.; Majumdar, P.; Makariev, M.; Maneva, G.; Mang, N.; Manganaro, M.; Mangano, S.; Mannheim, K.; Mariotti, M.; Martínez, M.; Mas-Aguilar, A.; Mazin, D.; Menchiari, S.; Mender, S.; Mićanović, S.; Miceli, D.; Miener, T.; Miranda, J. M.; Mirzoyan, R.; Molina, E.; Mondal, H. A.; Moralejo, A.; Morcuende, D.; Moreno, V.; Nakamori, T.; Nanci, K.; Nava, L.; Neustroev, V.; Nievas Rosillo, M.; Nigro, C.; Nilsson, K.; Nishijima, K.; Njoh Ekoume, T.; Noda, K.; Nozaki, S.; Ohtani, Y.; Oka, T.; Okumura, A.; Otero-Santos, J.; Paiano, S.; Palatiello, M.; Paneque, D.; Paoletti, R.; Paredes, J. M.; Pavletić, L.; Persic, M.; Pihet, M.; Pirola, G.; Podobnik, F.; Prada Moroni, P. G.; Prandini, E.; Principe, G.; Priyadarshi, C.; Rhode, W.; Ribó, M.; Rico, J.; Righi, C.; Rugliancich, A.; Sahakyan, N.; Saito, T.; Sakurai, S.; Satalecka, K.; Saturni, F. G.; Schleicher, B.; Schmidt, K.; Schmuckermaier, F.; Schubert, J. L.; Schweizer, T.; Sitarek, J.; Sliusar, V.; Sobczynska, D.; Spolon, A.; Stamerra, A.; Strišković, J.; Strom, D.; Strzys, M.; Suda, Y.; Suric, T.; Tajima, H.; Takahashi, M.; Takeishi, R.; Tavecchio, F.; Temnikov, P.; Terauchi, K.; Terzić, T.; Teshima, M.; Tosti, L.; Truzzi, S.; Tutone, A.; Ubach, S.; Van Scherpenberg, J.; Vazquez Acosta, M.; Ventura, S.; Verguillo, V.; Viale, I.; Vigorito, C. F.; Vitale, Y.; Vovk, I.; Walter, R.; Will, M.; Wunderlich, C.; Yamamoto, T.; Zarić, D.; Magic Collaboration; Cerruti, M.; Acosta-Pulido, J. A.; Apolonio, G.; Bachev, R.; Baloković, M.; Benítez, E.; Björklund, I.; Bozhilov, V.; Brown, L. F.; Bugg, A.; Carbonell, W.; Carnerero, M. I.; Carosati, D.; Casadio, C.; Chamani, W.; Chen, W. P.; Chigladze, R. A.; Damjanovic, G.; Epps, K.; Erkenov, A.; Feige, M.; Finke, J.; Fuentes, A.; Gazeas, K.; Giroletti, M.; Grishina, T. S.; Gupta, A. C.; Gurwell, M. A.; Heidemann, E.; Hiriart, D.; Hou, W. J.; Hovatta, T.; Ibryamov, S.; Joner, M. D.; Jorstad, S. G.; Kania, J.; Kiehlmann, S.; Kimeridze, G. N.; Kopatskaya, E. N.; Kopp, M.; Korte, M.; Kotas, B.; Koyama, S.; Kramer, J. A.; Kunkel, L.; Kurtanidze, S. O.; Kurtanidze, O. M.; Lähteenmäki, A.; López, J. M.; Larionov, V. M.; Larionova, E. G.; Larionova, L. V.; Leto, C.; Lorey, C.; Mújica, R.; Madejski, G. M.; Marchili, N.; Marscher, A. P.; Minev, M.; Modaresi, A.; Morozova, D. A.; Mufakharov, T.; Myserlis, I.; Nikiforova, A. A.; Nikolashvili, M. G.; Ovcharov, E.; Perri, M.; Raiteri, C. M.; Readhead, A. C. S.; Reimer, A.; Reinhard, D.; Righini, S.; Rosenlehner, K.; Sadun, A. C.; Savchenko, S. S.; Scherbantini, A.; Schneider, L.; Schoch, K.; Seifert, D.; Semkov, E.; Sigua, L. A.; Singh, C.; Sola, P.; Sotnikova, Y.; Spencer, M.; Steineke, R.; Stojanovic, M.; Strigachev, A.; Tornikoski, M.; Traianou, E.; Tramacere, A.; Troitskaya, Yu. V.; Troitskiy, I. S.; Trump, J. B.; Tsai, A.; Valcheva, A.; Vasilyev, A. A.; Verrecchia, F.; Villata, M.; Vince, O.; Vrontaki, K.; Weaver,

- Z. R.; Zaharieva, E.; Zottmann, N. "Multimessenger Characterization of Markarian 501 during Historically Low X-Ray and  $\gamma$ -Ray Activity," *The Astrophysical Journal Supplement Series*, 266, 37, 2023.
- Aberfelds, A.; Bartkiewicz, A.; Szymczak, M.; Steinbergs, J.; Surcis, G.; Kobak, A.; Durjasz, M.; Shmeld, I. "Milliarcsecond structure and variability of methanol maser emission in three high-mass protostars," *Monthly Notices of the Royal Astronomical Society*, 524, 599, 2023.
- Afzal, Adeela; Agazie, Gabriella; Anumarlapudi, Akash; Archibald, Anne M.; Arzoumanian, Zaven; Baker, Paul T.; Bécsy, Bence; Blanco-Pillado, Jose Juan; Blecha, Laura; Boddy, Kimberly K.; Brazier, Adam; Brook, Paul R.; Burke-Spolaor, Sarah; Burnette, Rand; Case, Robin; Charisi, Maria; Chatterjee, Shami; Chatziioannou, Katerina; Cheeseboro, Belinda D.; Chen, Siyuan; Cohen, Tyler; Cordes, James M.; Cornish, Neil J.; Crawford, Fronefield; Cromartie, H. Thankful; Crowter, Kathryn; Cutler, Curt J.; Decesar, Megan E.; Degan, Dallas; Demorest, Paul B.; Deng, Heling; Dolch, Timothy; Drachler, Brendan; Von Eckardstein, Richard; Ferrara, Elizabeth C.; Fiore, William; Fonseca, Emmanuel; Freedman, Gabriel E.; Garver-Daniels, Nate; Gentile, Peter A.; Gersbach, Kyle A.; Glaser, Joseph; Good, Deborah C.; Guertin, Lydia; Gültekin, Kayhan; Hazboun, Jeffrey S.; Hourihane, Sophie; Islo, Kristina; Jennings, Ross J.; Johnson, Aaron D.; Jones, Megan L.; Kaiser, Andrew R.; Kaplan, David L.; Kelley, Luke Zoltan; Kerr, Matthew; Key, Joey S.; Laal, Nima; Lam, Michael T.; Lamb, William G.; Lazio, T. Joseph W.; Lee, Vincent S. H.; Lewandowska, Natalia; Lino Dos Santos, Rafael R.; Littenberg, Tyson B.; Liu, Tingting; Lorimer, Duncan R.; Luo, Jing; Lynch, Ryan S.; Ma, Chung-Pei; Madison, Dustin R.; Mcewen, Alexander; Mckee, James W.; McLaughlin, Maura A.; Mcmann, Natasha; Meyers, Bradley W.; Meyers, Patrick M.; Mingarelli, Chiara M. F.; Mitridate, Andrea; Nay, Jonathan; Natarajan, Priyamvada; Ng, Cherry; Nice, David J.; Ocker, Stella Koch; Olum, Ken D.; Pennucci, Timothy T.; Perera, Benetge B. P.; Petrov, Polina; Pol, Nihan S.; Radovan, Henri A.; Ransom, Scott M.; Ray, Paul S.; Romano, Joseph D.; Sardesai, Shashwat C.; Schmiedekamp, Ann; Schmiedekamp, Carl; Schmitz, Kai; Schröder, Tobias; Schult, Levi; Shapiro-Albert, Brent J.; Siemens, Xavier; Simon, Joseph; Siwek, Magdalena S.; Stairs, Ingrid H.; Stinebring, Daniel R.; Stovall, Kevin; Stratmann, Peter; Sun, Jerry P.; Susobhanan, Abhimanyu; Swiggum, Joseph K.; Taylor, Jacob; Taylor, Stephen R.; Trickle, Tanner; Turner, Jacob E.; Unal, Caner; Vallisneri, Michele; Verma, Sonali; Vigeland, Sarah J.; Wahl, Haley M.; Wang, Qiaohong; Witt, Caitlin A.; Wright, David; Young, Olivia; Zurek, Kathryn M.; Nanograv Collaboration "The NANOGrav 15 yr Data Set: Search for Signals from New Physics," *The Astrophysical Journal*, 951, L11, 2023.
- Agazie, Gabriella; Alam, Md Faisal; Anumarlapudi, Akash; Archibald, Anne M.; Arzoumanian, Zaven; Baker, Paul T.; Bécsy, Bence; Blecha, Laura; Bonidle, Victoria; Brazier, Adam; Brook, Paul R.; Burke-Spolaor, Sarah; Bécsy, Bence; Chapman, Christopher; Charisi, Maria; Chatterjee, Shami; Cohen, Tyler; Cordes, James M.; Cornish, Neil J.; Crawford, Fronefield; Cromartie, H. Thankful; Crowter, Kathryn; Decesar, Megan E.; Demorest, Paul B.; Dolch, Timothy; Drachler, Brendan; Ferrara, Elizabeth C.; Fiore, William; Fonseca, Emmanuel; Freedman, Gabriel E.; Garver-Daniels, Nate; Gentile, Peter A.; Glaser, Joseph; Good, Deborah C.; Gültekin, Kayhan; Hazboun, Jeffrey S.; Jennings, Ross J.; Jessup, Cody; Johnson, Aaron D.; Jones, Megan L.; Kaiser, Andrew R.; Kaplan, David L.; Kelley, Luke Zoltan; Kerr, Matthew; Key, Joey S.; Kuske, Anastasia; Laal, Nima; Lam, Michael T.; Lamb, William G.; Lazio, T. Joseph W.; Lewandowska, Natalia; Lin, Ye; Liu, Tingting; Lorimer, Duncan R.; Luo, Jing; Lynch, Ryan S.; Ma, Chung-Pei; Madison, Dustin R.; Maraccini, Kaleb; Mcewen, Alexander; Mckee, James W.; McLaughlin, Maura A.; Mcmann, Natasha; Meyers, Bradley W.; Mingarelli, Chiara M. F.; Mitridate, Andrea; Ng, Cherry; Nice, David J.; Ocker, Stella Koch; Olum, Ken D.; Panciu, Elisa; Pennucci, Timothy T.; Perera, Benetge B. P.; Pol, Nihan S.; Radovan, Henri A.; Ransom, Scott M.; Ray, Paul S.; Romano, Joseph D.; Salo, Laura; Sardesai, Shashwat C.; Schmiedekamp, Carl; Schmiedekamp, Ann; Schmitz, Kai; Shapiro-Albert, Brent J.; Siemens, Xavier; Simon, Joseph; Siwek, Magdalena S.; Stairs, Ingrid H.; Stinebring, Daniel R.; Stovall, Kevin; Susobhanan, Abhimanyu; Swiggum, Joseph K.; Taylor, Jacob; Taylor, Stephen R.; Turner, Jacob E.; Unal, Caner; Vallisneri, Michele; Van Haasteren, Rutger; Vigeland, Sarah J.; Wahl, Haley M.; Wang, Qiaohong; Witt, Caitlin A.; Young, Olivia; Nanograv Collaboration "The NANOGrav 15 yr Data Set: Observations and Timing of 68 Millisecond Pulsars," *The Astrophysical Journal*, 951, L9, 2023.
- Agazie, Gabriella; Anumarlapudi, Akash; Archibald, Anne M.; Arzoumanian, Zaven; Baker, Paul T.; Bécsy, Bence; Blecha, Laura; Brazier, Adam; Brook, Paul R.; Burke-Spolaor, Sarah; Burnette, Rand; Case, Robin; Charisi, Maria; Chatterjee, Shami; Chatziioannou, Katerina; Cheeseboro, Belinda D.; Chen, Siyuan; Cohen, Tyler; Cordes, James M.; Cornish, Neil J.; Crawford, Fronefield; Cromartie, H. Thankful; Crowter, Kathryn; Cutler, Curt J.; Decesar, Megan E.; Degan, Dallas; Demorest, Paul B.; Deng, Heling; Dolch, Timothy; Drachler, Brendan; Ellis, Justin A.; Ferrara, Elizabeth C.; Fiore, William; Fonseca, Emmanuel; Freedman, Gabriel E.; Garver-Daniels, Nate; Gentile, Peter A.; Gersbach, Kyle A.; Glaser, Joseph; Good, Deborah C.; Gültekin, Kayhan; Hazboun, Jeffrey S.; Hourihane, Sophie; Islo, Kristina; Jennings, Ross J.; Johnson, Aaron D.; Jones, Megan L.; Kaiser, Andrew R.; Kaplan, David L.; Kelley, Luke Zoltan; Kerr, Matthew; Key, Joey S.; Klein, Tonia C.; Laal, Nima; Lam, Michael T.; Lamb, William G.; Lazio, T. Joseph W.; Lewandowska, Natalia; Littenberg, Tyson B.; Liu, Tingting; Lommen, Andrea; Lorimer, Duncan R.; Luo, Jing; Lynch, Ryan S.; Ma, Chung-Pei; Madison, Dustin R.; Mattson, Margaret A.; Mcewen, Alexander; Mckee, James W.; McLaughlin, Maura A.; Mcmann, Natasha; Meyers, Bradley W.; Meyers, Patrick M.; Mingarelli, Chiara M. F.; Mitridate, Andrea; Natarajan, Priyamvada; Ng, Cherry; Nice, David J.; Ocker, Stella Koch; Olum, Ken D.; Pennucci, Timothy T.; Perera, Benetge B. P.; Petrov, Polina; Pol, Nihan S.; Radovan, Henri A.; Ransom, Scott M.; Ray, Paul S.; Romano, Joseph D.; Sardesai, Shashwat C.; Schmiedekamp, Ann; Schmiedekamp, Carl; Schmitz, Kai; Schult, Levi; Shapiro-Albert, Brent J.; Siemens, Xavier; Simon, Joseph; Siwek, Magdalena S.; Stairs, Ingrid H.; Stinebring, Daniel R.; Stovall, Kevin; Sun, Jerry P.; Susobhanan, Abhimanyu; Swiggum, Joseph K.; Taylor, Jacob; Taylor, Stephen R.; Turner, Jacob E.; Unal, Caner; Vallisneri, Michele; Van Haasteren, Rutger; Vigeland, Sarah J.; Wahl, Haley M.; Wang, Qiaohong; Witt, Caitlin A.; Young, Olivia; Nanograv Collaboration "The NANOGrav 15 yr Data Set: Evidence for a Gravitational-wave Background," *The Astrophysical Journal*, 951, L8, 2023.
- Agazie, Gabriella; Anumarlapudi, Akash; Archibald, Anne M.; Arzoumanian, Zaven; Baker, Paul T.; Bécsy, Bence; Blecha, Laura; Brazier, Adam; Brook, Paul R.; Burke-Spolaor, Sarah; Case, Robin; Casey-Clyde, J. Andrew; Charisi, Maria; Chatterjee, Shami; Cohen, Tyler; Cordes, James M.; Cornish, Neil J.; Crawford, Fronefield; Cromartie, H. Thankful; Crowter, Kathryn; Decesar, Megan E.; Demorest, Paul B.; Digman, Matthew C.; Dolch, Timothy; Drachler, Brendan; Ferrara, Elizabeth C.; Fiore, William; Fonseca, Emmanuel; Freedman, Gabriel E.; Garver-Daniels, Nate; Gentile, Peter A.; Glaser, Joseph; Good, Deborah C.; Gültekin, Kayhan; Hazboun, Jeffrey S.; Hourihane, Sophie; Jennings, Ross J.; Johnson, Aaron D.; Jones, Megan L.; Kaiser, Andrew R.; Kaplan, David L.; Kelley, Luke Zoltan; Kerr, Matthew; Key, Joey S.; Laal, Nima; Lam, Michael T.; Lamb, William G.; Lazio, T. Joseph W.; Lewandowska, Natalia; Liu, Tingting; Lorimer, Duncan R.; Luo, Jing; Lynch, Ryan S.; Ma, Chung-Pei; Madison, Dustin R.; Mcewen, Alexander; Mckee, James W.; McLaughlin, Maura A.; Mcmann, Natasha; Meyers, Bradley W.; Meyers, Patrick M.; Mingarelli, Chiara M. F.; Mitridate, Andrea; Ng, Cherry; Nice, David J.; Ocker, Stella Koch; Olum, Ken D.; Pennucci, Timothy T.; Perera, Benetge B. P.; Petrov, Polina; Pol, Nihan S.; Radovan, Henri A.; Ransom, Scott M.; Ray, Paul S.; Romano, Joseph D.; Sardesai, Shashwat C.; Schmiedekamp, Ann; Schmiedekamp, Carl; Schmitz, Kai; Shapiro-Albert, Brent J.; Siemens, Xavier; Simon, Joseph; Siwek, Magdalena S.; Stairs, Ingrid H.; Stinebring, Daniel R.; Stovall, Kevin; Susobhanan, Abhimanyu; Swiggum, Joseph K.; Taylor, Jacob; Taylor, Stephen R.; Turner, Jacob E.; Unal, Caner; Vallisneri, Michele; Van Haasteren, Rutger; Vigeland, Sarah J.; Wahl, Haley M.; Witt, Caitlin A.; Young, Olivia; Nanograv Collaboration "The NANOGrav 15 yr Data Set: Search for Signals from New Physics," *The Astrophysical Journal*, 951, L11, 2023.

## APPENDIX A: PUBLICATIONS

- Young, Olivia; Nanograv Collaboration "The NANOGrav 15 yr Data Set: Bayesian Limits on Gravitational Waves from Individual Supermassive Black Hole Binaries," *The Astrophysical Journal*, 951, L50, 2023.
- Agazie, Gabriella; Anumalapludi, Akash; Archibald, Anne M.; Arzoumanian, Zaven; Baker, Paul T.; Bécsy, Bence; Blecha, Laura; Brazier, Adam; Brook, Paul R.; Burke-Spolaor, Sarah; Casey-Clyde, J. Andrew; Charisi, Maria; Chatterjee, Shami; Cohen, Tyler; Cordes, James M.; Cornish, Neil J.; Crawford, Fronefield; Cromartie, H. Thankful; Crowter, Kathryn; Decesar, Megan E.; Demorest, Paul B.; Dolch, Timothy; Drachler, Brendan; Ferrara, Elizabeth C.; Fiore, William; Fonseca, Emmanuel; Freedman, Gabriel E.; Gardiner, Emiko; Garver-Daniels, Nate; Gentile, Peter A.; Glaser, Joseph; Good, Deborah C.; Gültekin, Kayhan; Hazboun, Jeffrey S.; Jennings, Ross J.; Johnson, Aaron D.; Jones, Megan L.; Kaiser, Andrew R.; Kaplan, David L.; Kelley, Luke Zoltan; Kerr, Matthew; Key, Joey S.; Laal, Nima; Lam, Michael T.; Lamb, William G.; Lazio, T. Joseph W.; Lewandowska, Natalia; Liu, Tingting; Lorimer, Duncan R.; Luo, Jing; Lynch, Ryan S.; Ma, Chung-Pei; Madison, Dustin R.; McEwen, Alexander; Mckee, James W.; Mclaughlin, Maura A.; Mcmann, Natasha; Meyers, Bradley W.; Mingarelli, Chiara M. F.; Mitridate, Andrea; Ng, Cherry; Nice, David J.; Ocker, Stella Koch; Olum, Ken D.; Pennucci, Timothy T.; Perera, Benetge B. P.; Pol, Nihan S.; Radovan, Henri A.; Ransom, Scott M.; Ray, Paul S.; Romano, Joseph D.; Runnoe, Jessie C.; Sardesai, Shashwat C.; Schmiedekamp, Ann; Schmiedekamp, Carl; Schmitz, Kai; Schult, Levi; Shapiro-Albert, Brent J.; Siemens, Xavier; Simon, Joseph; Siwek, Magdalena S.; Stairs, Ingrid H.; Stinebring, Daniel R.; Stovall, Kevin; Susobhanan, Abhimanyu; Swiggum, Joseph K.; Taylor, Stephen R.; Turner, Jacob E.; Unal, Caner; Vallisneri, Michele; Vigeland, Sarah J.; Wahl, Haley M.; Wang, Qiaohong; Witt, Caitlin A.; Young, Olivia "The NANOGrav 15 yr Data Set: Search for Anisotropy in the Gravitational-wave Background," *The Astrophysical Journal*, 956, L3, 2023.
- Agazie, Gabriella; Anumalapludi, Akash; Archibald, Anne M.; Arzoumanian, Zaven; Baker, Paul T.; Bécsy, Bence; Blecha, Laura; Brazier, Adam; Brook, Paul R.; Burke-Spolaor, Sarah; Charisi, Maria; Chatterjee, Shami; Cohen, Tyler; Cordes, James M.; Cornish, Neil J.; Crawford, Fronefield; Cromartie, H. Thankful; Crowter, Kathryn; Decesar, Megan E.; Demorest, Paul B.; Dolch, Timothy; Drachler, Brendan; Ferrara, Elizabeth C.; Fiore, William; Fonseca, Emmanuel; Freedman, Gabriel E.; Garver-Daniels, Nate; Gentile, Peter A.; Glaser, Joseph; Good, Deborah C.; Guertin, Lydia; Gültekin, Kayhan; Hazboun, Jeffrey S.; Jennings, Ross J.; Johnson, Aaron D.; Jones, Megan L.; Kaiser, Andrew R.; Kaplan, David L.; Kelley, Luke Zoltan; Kerr, Matthew; Key, Joey S.; Laal, Nima; Lam, Michael T.; Lamb, William G.; Lazio, T. Joseph W.; Lewandowska, Natalia; Liu, Tingting; Lorimer, Duncan R.; Luo, Jing; Lynch, Ryan S.; Ma, Chung-Pei; Madison, Dustin R.; McEwen, Alexander; Mckee, James W.; Mclaughlin, Maura A.; Mcmann, Natasha; Meyers, Bradley W.; Mingarelli, Chiara M. F.; Mitridate, Andrea; Ng, Cherry; Nice, David J.; Ocker, Stella Koch; Olum, Ken D.; Pennucci, Timothy T.; Perera, Benetge B. P.; Pol, Nihan S.; Radovan, Henri A.; Ransom, Scott M.; Ray, Paul S.; Romano, Joseph D.; Sardesai, Shashwat C.; Schmiedekamp, Ann; Schmiedekamp, Carl; Schmitz, Kai; Shapiro-Albert, Brent J.; Siemens, Xavier; Simon, Joseph; Siwek, Magdalena S.; Stairs, Ingrid H.; Stinebring, Daniel R.; Stovall, Kevin; Susobhanan, Abhimanyu; Swiggum, Joseph K.; Taylor, Stephen R.; Turner, Jacob E.; Unal, Caner; Vallisneri, Michele; Vigeland, Sarah J.; Wahl, Haley M.; Wang, Qiaohong; Witt, Caitlin A.; Young, Olivia "The NANOGrav 15 yr Data Set: Detector Characterization and Noise Budget," *The Astrophysical Journal*, 951, L10, 2023.
- Agazie, Gabriella; Anumalapludi, Akash; Archibald, Anne M.; Baker, Paul T.; Bécsy, Bence; Blecha, Laura; Bonilla, Alexander; Brazier, Adam; Brook, Paul R.; Burke-Spolaor, Sarah; Burnette, Rand; Case, Robin; Casey-Clyde, J. Andrew; Charisi, Maria; Chatziioannou, Katerina; Cheeseboro, Belinda D.; Chen, Siyuan; Cohen, Tyler; Cordes, James M.; Cornish, Neil J.; Crawford, Fronefield; Cromartie, H. Thankful; Crowter, Kathryn; Cutler, Curt J.; D'Orazio, Daniel J.; Decesar, Megan E.; Degan, Dallas; Demorest, Paul B.; Deng, Heling; Dolch, Timothy; Drachler, Brendan; Ferrara, Elizabeth C.; Fiore, William; Fonseca, Emmanuel; Freedman, Gabriel E.; Gardiner, Emiko; Garver-Daniels, Nate; Gentile, Peter A.; Glaser, Joseph; Good, Deborah C.; Gültekin, Kayhan; Hazboun, Jeffrey S.; Jennings, Ross J.; Johnson, Aaron D.; Jones, Megan L.; Kaiser, Andrew R.; Kaplan, David L.; Kelley, Luke Zoltan; Kerr, Matthew; Key, Joey S.; Laal, Nima; Lam, Michael T.; Lamb, William G.; Lazio, T. Joseph W.; Lewandowska, Natalia; Liu, Tingting; Lorimer, Duncan R.; Luo, Jing; Lynch, Ryan S.; Ma, Chung-Pei; Madison, Dustin R.; McEwen, Alexander; Mckee, James W.; Mclaughlin, Maura A.; Mcmann, Natasha; Meyers, Bradley W.; Mingarelli, Chiara M. F.; Mitridate, Andrea; Ng, Cherry; Nice, David J.; Ocker, Stella Koch; Olum, Ken D.; Pennucci, Timothy T.; Perera, Benetge B. P.; Pol, Nihan S.; Radovan, Henri A.; Ransom, Scott M.; Ray, Paul S.; Romano, Joseph D.; Sardesai, Shashwat C.; Schmiedekamp, Ann; Schmiedekamp, Carl; Schmitz, Kai; Shapiro-Albert, Brent J.; Siemens, Xavier; Simon, Joseph; Siwek, Magdalena S.; Stairs, Ingrid H.; Stinebring, Daniel R.; Stovall, Kevin; Susobhanan, Abhimanyu; Swiggum, Joseph K.; Taylor, Stephen R.; Turner, Jacob E.; Unal, Caner; Vallisneri, Michele; Vigeland, Sarah J.; Wahl, Haley M.; Witt, Caitlin A.; Young, Olivia; Nanograv Collaboration "The NANOGrav 15 yr Data Set: Constraints on Supermassive Black Hole Binaries from the Gravitational-wave Background," *The Astrophysical Journal*, 952, L37, 2023.
- Agudo, I.; Amati, L.; An, T.; Bauer, F. E.; Benetti, S.; Bernardini, M. G.; Beswick, R.; Bhirombhakdi, K.; De Boer, T.; Branchesi, M.; Brennan, S. J.; Brocato, E.; Caballero-García, M. D.; Cappellaro, E.; Castro Rodríguez, N.; Castro-Tirado, A. J.; Chambers, K. C.; Chassande-Mottin, E.; Chaty, S.; Chen, T.-W.; Coleiro, A.; Covino, S.; D'Ammando, F.; D'Avanzo, P.; D'Elia, V.; Fiore, A.; Flörs, A.; Fraser, M.; Frey, S.; Frohmaier, C.; Fulton, M.; Galbany, L.; Gall, C.; Gao, H.; García-Rojas, J.; Ghirlanda, G.; Giarratana, S.; Gillanders, J. H.; Giroletti, M.; Gompertz, B. P.; Gromadzki, M.; Heintz, K. E.; Hjorth, J.; Hu, Y.-D.; Huber, M. E.; Inkenhaag, A.; Izzo, L.; Jin, Z. P.; Jonker, P. G.; Kann, D. A.; Kool, E. C.; Kotak, R.; Leloudas, G.; Levan, A. J.; Lin, C.-C.; Lyman, J. D.; Magnier, E. A.; Maguire, K.; Mandel, I.; Marcote, B.; Mata Sánchez, D.; Mattila, S.; Melandri, A.; Michałowski, M. J.; Moldon, J.; Nicholl, M.; Nicuesa Guelbenzu, A.; Oates, S. R.; Onori, F.; Orienti, M.; Paladino, R.; Paragi, Z.; Perez-Torres, M.; Pian, E.; Pignata, G.; Piranomonte, S.; Quirola-Vásquez, J.; Ragosta, F.; Rau, A.; Ronchini, S.; Rossi, A.; Sánchez-Ramírez, R.; Salafia, O. S.; Schulze, S.; Smartt, S. J.; Smith, K. W.; Sollerman, J.; Srivastav, S.; Starling, R. L. C.; Steeghs, D.; Stevance, H. F.; Tanvir, N. R.; Testa, V.; Torres, M. A. P.; Valeev, A.; Vergani, S. D.; Vescovi, D.; Wainscoat, R.; Watson, D.; Watters, K.; Wyrzykowski, Ł.; Yang, J.; Yang, S.; Young, D. R. "Panning for gold, but finding helium: Discovery of the ultra-stripped supernova SN 2019wxt from gravitational-wave follow-up observations," *Astronomy and Astrophysics*, 675, A201, 2023.
- Akins, Alex; Hofstadter, Mark; Butler, Bryan; Friedson, A. James; Molter, Edward; Parisi, Marzia; De Pater, Imke "Evidence of a Polar Cyclone on Uranus From VLA Observations," *Geophysical Research Letters*, 50, e2023GL102872, 2023.
- Albán, M.; Wylezalek, D. "Classifying the full SDSS-IV MaNGA Survey using optical diagnostic diagrams: Presentation of AGN catalogs in flexible apertures," *Astronomy and Astrophysics*, 674, A85, 2023.
- Algera, Hiddo S. B.; Inami, Hanae; Oesch, Pascal A.; Sommovigo, Laura; Bouwens, Rychard J.; Topping, Michael W.; Schouws, Sander; Stefanon, Mauro; Stark, Daniel P.; Aravena, Manuel; Barrufet, Laia; Da Cunha, Elisabete; Dayal, Pratika; Endsley, Ryan; Ferrara, Andrea; Fudamoto, Yoshinobu; Gonzalez, Valentino; Graziani, Luca; Hodge, Jacqueline A.; Hygate, Alexander P. S.; De Looze, Ilse; Nanayakkara, Themija; Schneider, Raffaella; Van Der Werf, Paul P. "The ALMA REBELS survey: the dust-obscured cosmic star formation rate density at redshift 7," *Monthly Notices of the Royal Astronomical Society*, 518, 6142, 2023.
- Allisandrakis, Costas E.; Bastian, Timothy; Shimojo, Masumi; Nindos,



- Alexander "Editorial: The Sun Seen with the Atacama Large mm and sub-mm Array (ALMA) - First Results \*," *Frontiers in Astronomy and Space Sciences*, 10, 9, 2023.
- Allakhverdyan, V. A.; Avrorin, A. D.; Avrorin, A. V.; Aynutdinov, V. M.; Bardachová, Z.; Belolaptikov, I. A.; Bondarev, E. A.; Borina, I. V.; Budnev, N. M.; Chepurinov, A. S.; Dik, V. Y.; Domogatsky, G. V.; Doroshenko, A. A.; Dvornický, R.; Dyachok, A. N.; Dzhalikbaev, Zh-A. M.; Eckerová, E.; Elzhov, T. V.; Fajt, L.; Gafarov, A. R.; Golubkov, K. V.; Gorshkov, N. S.; Gress, T. I.; Kebkal, K. G.; Kharuk, I.; Khramov, E. V.; Kolbin, M. M.; Konischev, K. V.; Korobchenko, A. V.; Koshechkin, A. P.; Kozhin, V. A.; Kruglov, M. V.; Kulepov, V. F.; Lemeshev, Y. E.; Milenin, M. B.; Mirgazov, R. R.; Naumov, D. V.; Nikolaev, A. S.; Petukhov, D. P.; Pliskovsky, E. N.; Rozanov, M. I.; Ryabov, E. V.; Safronov, G. B.; Seitova, D.; Shaybonov, B. A.; Shelepov, M. D.; Shilkin, S. D.; Shirokov, E. V.; Šimkovic, F.; Sirenko, A. E.; Skurikhin, A. V.; Solovjev, A. G.; Sorokovikov, M. N.; Štekl, I.; Stromakov, A. P.; Suvorova, O. V.; Tabolenko, V. A.; Ulzutuev, B. B.; Yablokova, Y. V.; Zaborov, D. N.; Zavyalov, S. I.; Zvezdov, D. Y.; Kosogorov, N. A.; Kovalev, Y. Y.; Lipunova, G. V.; Plavin, A. V.; Semikoz, D. V.; Troitsky, S. V.; Baikal-Gvd Collaboration "Search for directional associations between baikal gigaton volume detector neutrino-induced cascades and high-energy astrophysical sources," *Monthly Notices of the Royal Astronomical Society*, 526, 942, 2023.
- Alonso Herrero, A.; García-Burillo, S.; Pereira-Santaella, M.; Shimizu, T.; Combes, F.; Hicks, E. K. S.; Davies, R.; Ramos Almeida, C.; García-Bernete, I.; Hönig, S. F.; Levenson, N. A.; Packham, C.; Bellocchi, E.; Hunt, L. K.; Imanishi, M.; Ricci, C.; Roche, P. "AGN feedback in action in the molecular gas ring of the Seyfert galaxy NGC 7172," *Astronomy and Astrophysics*, 675, A88, 2023.
- Álvarez-Márquez, J.; Crespo Gómez, A.; Colina, L.; Neeleman, M.; Walter, F.; Labiano, A.; Pérez-González, P.; Bik, A.; Noorgaard-Nielsen, H. U.; Ostlin, G.; Wright, G.; Alonso-Herrero, A.; Azollini, R.; Caputi, K. I.; Eckart, A.; Le Fèvre, O.; García-Marín, M.; Greve, T. R.; Hjorth, J.; Ilbert, O.; Kendrew, S.; Pye, J. P.; Tikkanen, T.; Topinka, M.; Van Der Werf, P.; Ward, M.; Van Dishoeck, E. F.; Güdel, M.; Henning, Th.; Lagage, P. O.; Ray, T.; Waelkens, C. "MIRI/JWST observations reveal an extremely obscured starburst in the  $z = 6.9$  system SPT0311-58," *Astronomy and Astrophysics*, 671, A105, 2023.
- Amarantidis, Stergios; Afonso, Jose; Matute, Israel; Farrah, Duncan; Hopkins, Andrew; Messias, Hugo; Pappalardo, Ciro; Seymour, Nick "Tracing obscured galaxy build-up at high redshift using deep radio surveys," *Astronomy and Astrophysics*, 678, A116, 2023.
- Amiri, Mandana; Bandura, Kevin; Chen, Tianyue; Deng, Meiling; Dobbs, Matt; Fandino, Mateus; Foreman, Simon; Halpern, Mark; Hill, Alex S.; Hinshaw, Gary; Höfer, Carolin; Kania, Joseph; Landecker, T. L.; Maceachern, Joshua; Masui, Kiyoshi; Mena-Parra, Juan; Milutinovic, Nikola; Mirhosseini, Arash; Newburgh, Laura; Ordog, Anna; Pen, Ue-Li; Pinsonneault-Marotte, Tristan; Polzin, Ava; Reda, Alex; Renard, Andre; Shaw, J. Richard; Siegel, Seth R.; Singh, Saurabh; Vanderlinde, Keith; Wang, Haochen; Wiebe, Donald V.; Wulf, Dallas; Chime Collaboration "Detection of Cosmological 21 cm Emission with the Canadian Hydrogen Intensity Mapping Experiment," *The Astrophysical Journal*, 947, 16, 2023.
- An, Tao; Wang, Ailing; Liu, Yuanqi; Sotnikova, Yulia; Zhang, Yingkang; Aditya, J. N. H. S.; Jaiswal, Sumit; Khorunzhev, George; Lao, Baoqiang; Lin, Ruqiu; Mikhailov, Alexander; Mingaliev, Marat; Mufakharov, Timur; Sazonov, Sergey "Is the X-ray bright  $z = 5.5$  quasar SRGE J170245.3+130104 a blazar?," *Monthly Notices of the Royal Astronomical Society*, 519, 4047, 2023.
- Andersen, Bridget C.; Bandura, Kevin; Bhardwaj, Mohit; Boyle, P. J.; Brar, Charanjot; Cassanelli, Tomas; Chatterjee, S.; Chawla, Pragma; Cook, Amanda M.; Curtin, Alice P.; Dobbs, Matt; Dong, Fengqiu Adam; Faber, Jakob T.; Fandino, Mateus; Fonseca, Emmanuel; Gaensler, B. M.; Giri, Utkarsh; Herrera-Martin, Antonio; Hill, Alex S.; Ibiak, Aadaeze; Josephy, Alexander; Kaczmarek, Jane F.; Kader, Zarif; Kaspi, Victoria; Landecker, T. L.; Lanman, Adam E.; Lazda, Mattias; Leung, Calvin; Lin, Hsiu-Hsien; Masui, Kiyoshi W.; Mckinven, Ryan; Mena-Parra, Juan; Meyers, Bradley W.; Michilli, D.; Ng, Cherry; Pandhi, Ayush; Pearlman, Aaron B.; Pen, Ue-Li; Petroff, Emily; Pleunis, Ziggy; Rafiei-Ravandi, Masoud; Rahman, Mubdi; Ransom, Scott M.; Renard, Andre; Sand, Ketan R.; Sanghavi, Pranav; Scholz, Paul; Shah, Vishwangi; Shin, Kaitlyn; Siegel, Seth; Smith, Kendrick; Stairs, Ingrid; Su, Jianing; Tendulkar, Shriharsh P.; Vanderlinde, Keith; Wang, Haochen; Wulf, Dallas; Zwaniga, Andrew; Chime/Frb Collaboration "CHIME/FRB Discovery of 25 Repeating Fast Radio Burst Sources," *The Astrophysical Journal*, 947, 83, 2023.
- Andersen, Bridget C.; Fonseca, Emmanuel; Mckee, J. W.; Meyers, B. W.; Luo, Jing; Tan, C. M.; Stairs, I. H.; Kaspi, Victoria M.; Kerkwijk, M. H. Van; Bhardwaj, Mohit; Boyle, P. J.; Crowter, Kathryn; Demorest, Paul B.; Dong, Fengqiu A.; Good, Deborah C.; Kaczmarek, Jane F.; Leung, Calvin; Masui, Kiyoshi W.; Naidu, Arun; Ng, Cherry; Patel, Chitrag; Pearlman, Aaron B.; Pleunis, Ziggy; Rafiei-Ravandi, Masoud; Rahman, Mubdi; Ransom, Scott M.; Smith, Kendrick M.; Tendulkar, Shriharsh P. "CHIME Discovery of a Binary Pulsar with a Massive Nondegenerate Companion," *The Astrophysical Journal*, 943, 57, 2023.
- Anderson, L. D.; Liu, B.; Balser, Dana. S.; Bania, T. M.; Haffner, L. M.; Linville, Dylan J.; Luisi, Matteo; Wenger, Trey V. "Methods for Averaging Spectral Line Data," *Publications of the Astronomical Society of the Pacific*, 135, 114504, 2023.
- Andersson, Alex; Lintott, Chris; Fender, Rob; Bright, Joe; Carotenuto, Francesco; Driessen, Laura; Espinasse, Mathilde; Gasehalwe, Kelebogile; Heywood, Ian; Van Der Horst, Alexander J.; Motta, Sara; Rhodes, Lauren; Tremou, Evangelia; Williams, David R. A.; Woudt, Patrick; Zhang, Xian; Bloemen, Steven; Groot, Paul; Vreeswijk, Paul; Giarratana, Stefano; Saikia, Payaswini; Andersson, Jonas; Arroyo, Lizzeth Ruiz; Baert, Loic; Baumann, Matthew; Domainko, Wilfried; Eschweiler, Thorsten; Forsythe, Tim; Gaudenzi, Sauro; Grenier, Rachel Ann; Iannone, Davide; Lahoz, Karla; Melville, Kyle J.; De Sousa Nascimento, Marianne; Navarro, Leticia; Parthasarathi, Sai; Piilonen, Rahman; Najma; Smith, Jeffrey; Stewart, B.; Temoke, Newton; Tworek, Chloe; Whittle, Isabelle "Bursts from Space: MeerKAT - The first citizen science project dedicated to commensal radio transients," *Monthly Notices of the Royal Astronomical Society*, 523, 2219-2235, 2023.
- Andreon, S.; Romero, C.; Aussen, H.; Bhandarkar, T.; Devlin, M.; Dicker, S.; Ladjelate, B.; Lowe, I.; Mason, B.; Mroczkowski, T.; Raichoor, A.; Sarazin, C.; Trinchieri, G. "Witnessing the intracluster medium assembly at the cosmic noon in JKCS 041," *Monthly Notices of the Royal Astronomical Society*, 522, 4301-4309, 2023.
- Andrianjafy, J. C.; Heeralal-Issur, N.; Deshpande, A. A.; Golap, K.; Woudt, P.; Caleb, M.; Barr, E. D.; Chen, W.; Jankowski, F.; Kramer, M.; Stappers, B. W.; Wu, J. "Image plane detection of FRB121102 with the MeerKAT radio telescope," *Monthly Notices of the Royal Astronomical Society*, 518, 3462, 2023.
- Anna-Thomas, Reshma; Connor, Liam; Dai, Shi; Feng, Yi; Burke-Spolaor, Sarah; Beniamini, Paz; Yang, Yuan-Pei; Zhang, Yong-Kun; Aggarwal, Kshitij; Law, Casey J.; Li, Di; Niu, Chenhui; Chatterjee, Shami; Cruces, Marilyn; Duan, Ran; Filipovic, Miroslav D.; Hobbs, George; Lynch, Ryan S.; Miao, Chenchen; Niu, Jiarui; Ocker, Stella K.; Tsai, Chao-Wei; Wang, Pei; Xue, Mengyao; Yao, Ju-Mei; Yu, Wenfei; Zhang, Bing; Zhang, Lei; Zhu, Shiqiang; Zhu, Weiwei "Magnetic field reversal in the turbulent environment around a repeating fast radio burst," *Science*, 380, 599, 2023.
- Annunziatella, Marianna; Sajina, Anna; Stefanon, Mauro; Marchesini, Danilo; Lacy, Mark; Labbé, Ivo; Houston, Lilianna; Bezanson, Rachel; Egami, Eiichi; Fan, Xiaohui; Farrah, Duncan; Greene, Jenny; Goulding, Andy; Lin, Yen-Ting; Liu, Xin; Moutard, Thibaud; Ono, Yoshiaki; Ouchi, Masami; Sawicki, Marcin; Surace, Jason; Whitaker, Katherine "The Spitzer Coverage of HSC-Deep with IRAC for Z studies (SHIRAZ). I. IRAC Mosaics," *The Astronomical Journal*, 166, 25, 2023.
- Antilen, Juanita; Casassus, Simon; Cieza, Lucas A.; González-Ruilova, Camilo "Gas distribution in ODISEA sources from ALMA long-baseline observations in 12CO(2-1)," *Monthly Notices of the Royal Astronomical*

## APPENDIX A: PUBLICATIONS

- Society, 522, 2611, 2023.
- Anumarlapudi, Akash; Ehlke, Anna; Jones, Megan L.; Kaplan, David L.; Dobie, Dougal; Lenc, Emil; Leung, James K.; Murphy, Tara; Pritchard, Joshua; Stewart, Adam J.; Sengar, Rahul; Anderson, Craig; Banfield, Julie; Heald, George; Hotan, Aidan W.; McConnell, David; Moss, Vanessa A.; Raja, Wasim; Whiting, Matthew T. "Characterizing Pulsars Detected in the Rapid ASKAP Continuum Survey," *The Astrophysical Journal*, 956, 28, 2023.
- Anumarlapudi, Akash; Swiggum, Joseph K.; Kaplan, David L.; Fichtenbauer, Travis D. J. "A Pilot Study of Nulling in 22 Pulsars Using Mixture Modeling," *The Astrophysical Journal*, 948, 32, 2023.
- Appleton, P. N.; Guillard, P.; Emonts, Bjorn; Boulanger, Francois; Togi, Aditya; Reach, William T.; Alatalo, Kathleen; Cluver, M.; Diaz Santos, T.; Duc, P.-A.; Gallagher, S.; Ogle, P.; O'Sullivan, E.; Voggel, K.; Xu, C. K. "Multiphase Gas Interactions on Subarcsec Scales in the Shocked Intergalactic Medium of Stephan's Quintet with JWST and ALMA," *The Astrophysical Journal*, 951, 104, 2023.
- Arámburo-García, Andrés; Bondarenko, Kyrylo; Boyarsky, Alexey; Neronov, Andrii; Scaife, Anna; Sokolenko, Anastasia "The contribution of magnetized galactic outflows to extragalactic Faraday rotation," *Monthly Notices of the Royal Astronomical Society*, 519, 4030, 2023.
- Arango-Toro, R. C.; Ciesla, L.; Ilbert, O.; Magnelli, B.; Jiménez-Andrade, E. F.; Buat, V. "Probing the timescale of the 1.4 GHz radio emissions as a star formation tracer," *Astronomy and Astrophysics*, 675, A126, 2023.
- Arce-Tord, Carla; Casassus, Simon; Dent, William R. F.; Pérez, Sebastián; Cárcamo, Miguel; Weber, Philipp; Engler, Natalia; Cieza, Lucas A.; Hales, Antonio; Zurlo, Alice; Marino, Sebastian "Radio-continuum decrements associated to shadowing from the central warp in transition disc DoAr 44," *Monthly Notices of the Royal Astronomical Society*, 526, 2077, 2023.
- Armus, L.; Lai, T.; U. V.; Larson, K. L.; Diaz-Santos, T.; Evans, A. S.; Malkan, M. A.; Rich, J.; Medling, A. M.; Law, D. R.; Inami, H.; Muller-Sanchez, F.; Charmandaris, V.; Van Der Werf, P.; Stierwalt, S.; Linden, S.; Privon, G. C.; Barcos-Muñoz, L.; Hayward, C.; Song, Y.; Appleton, P.; Aalto, S.; Bohn, T.; Böker, T.; Brown, M. J. I.; Finnerty, L.; Howell, J.; Iwasawa, K.; Kemper, F.; Marshall, J.; Mazzarella, J. M.; Mckinney, J.; Murphy, E. J.; Sanders, D.; Surace, J. "GOALS-JWST: Mid-infrared Spectroscopy of the Nucleus of NGC 7469," *The Astrophysical Journal*, 942, L37, 2023.
- Artur De La Villarmois, E.; Guzmán, V. V.; Yang, Y.-L.; Zhang, Y.; Sakai, N. "The Perseus ALMA Chemical Survey (PEACHES). III. Sulfur-bearing species tracing accretion and ejection processes in young protostars," *Astronomy and Astrophysics*, 678, A124, 2023.
- Arunalantham, Nicole; Gronke, Max; Fiorellino, Eleonora; Gameiro, Jorge Filipe; Frasca, Antonio; Green, Joel; Chang, Seok-Jun; Claes, Rik A. B.; Espaillat, Catherine C.; France, Kevin; Herczeg, Gregory J.; Manara, Carlo F.; Venuti, Laura; Abraham, Péter; Alexander, Richard; Bouvier, Jerome; Campbell-White, Justyn; Eislöffel, Jochen; Fischer, William J.; Kóspál, Ágnes; Vioque, Miguel "Lya Scattering Models Trace Accretion and Outflow Kinematics in T Tauri Systems," *The Astrophysical Journal*, 944, 185, 2023.
- Arzoumanian, Zaven; Baker, Paul T.; Blecha, Laura; Blumer, Harsha; Brazier, Adam; Brook, Paul R.; Burke-Spolaor, Sarah; Bécsy, Bence; Casey-Clyde, J. Andrew; Charisi, Maria; Chatterjee, Shami; Chen, Siyuan; Cordes, James M.; Cornish, Neil J.; Crawford, Fronefield; Cromartie, H. Thankful; Decesar, Megan E.; Demorest, Paul B.; Dolch, Timothy; Drachler, Brendan; Ellis, Justin A.; Ferrara, E. C.; Fiore, William; Fonseca, Emmanuel; Freedman, Gabriel E.; Garver-Daniels, Nathan; Gentile, Peter A.; Glaser, Joseph; Good, Deborah C.; Gültekin, Kayhan; Hazboun, Jeffrey S.; Jennings, Ross J.; Johnson, Aaron D.; Jones, Megan L.; Kaiser, Andrew R.; Kaplan, David L.; Kelley, Luke Zoltan; Key, Joey Shapiro; Laal, Nima; Lam, Michael T.; Lamb, William G.; W. Lazio, T. Joseph; Lewandowska, Natalia; Liu, Tingting; Lorimer, Duncan R.; Luo, Jing; Lynch, Ryan S.; Madison, Dustin R.; McEwen, Alexander; McLaughlin, Maura A.; Mingarelli, Chiara M. F.; Ng, Cherry; Nice, David J.; Ocker, Stella Koch; Olum, Ken D.; Pennucci, Timothy T.; Pol, Nihan S.; Ransom, Scott M.; Ray, Paul S.; Romano, Joseph D.; Shapiro-Albert, Brent J.; Siemens, Xavier; Simon, Joseph; Siwek, Magdalena; Spiewak, Renée; Stairs, Ingrid H.; Stinebring, Daniel R.; Stovall, Kevin; Swiggum, Joseph K.; Sydnor, Jessica; Taylor, Stephen R.; Turner, Jacob E.; Vallisneri, Michele; Vigeland, Sarah J.; Wahl, Haley M.; Walsh, Gregory; Witt, Caitlin A.; Young, Olivia; Nanograv Collaboration "The NANOGrav 12.5 yr Data Set: Bayesian Limits on Gravitational Waves from Individual Supermassive Black Hole Binaries," *The Astrophysical Journal*, 951, L28, 2023.
- Asaki, Yoshiharu; Maud, Luke T.; Francke, Harold; Nagai, Hiroshi; Petry, Dirk; Fomalont, Edward B.; Humphreys, Elizabeth; Richards, Anita M. S.; Wong, Ka Tat; Dent, William; Hirota, Akihiko; Fernandez, Jose Miguel; Takahashi, Satoko; Hales, Antonio S. "ALMA High-frequency Long Baseline Campaign in 2021: Highest Angular Resolution Submillimeter Wave Images for the Carbon-rich Star R Lep," *The Astrophysical Journal*, 958, 86, 2023.
- Ashimbaeva, N. T.; Lekht, E. E.; Krasnov, V. V.; Tolmachev, A. M. "A Study of Variability of the Stokes Parameters and the Magnetic Field of G43.8-0.1 in the OH Line 1665 MHz," *Astronomy Reports*, 67, 230, 2023.
- Aso, Yusuke; Kwon, Woojin; Ohashi, Nagayoshi; Jørgensen, Jes K.; Tobin, John J.; Aikawa, Yuri; De Gregorio-Monsalvo, Itziar; Han, Ilseung; Kido, Miyu; Koch, Patrick M.; Lai, Shih-Ping; Lee, Chang Won; Lee, Jeong-Eun; Li, Zhi-Yun; Lin, Zhe-Yu Daniel; Looney, Leslie W.; Narayanan, Suchitra; Phuong, Nguyen Thi; Sai, Jinshi (Insa Choi); Saigo, Kazuya; Santamaría-Miranda, Alejandro; Sharma, Rajeeb; Takakuwa, Shigehisa; Thieme, Travis J.; Tomida, Kengo; Williams, Jonathan P.; Yen, Hsi-Wei "Early Planet Formation in Embedded Disks (eDisk). VI. Kinematic Structures around the Very-low-mass Protostar IRAS 16253-2429," *The Astrophysical Journal*, 954, 101, 2023.
- Audibert, A.; Ramos Almeida, C.; García-Burillo, S.; Combes, F.; Bischetti, M.; Meenakshi, M.; Mukherjee, D.; Bicknell, G.; Wagner, A. Y. "Jet-induced molecular gas excitation and turbulence in the Teacup," *Astronomy and Astrophysics*, 671, L12, 2023.
- Auge, Connor; Sanders, David; Treister, Ezequiel; Urry, C. Megan; Kirkpatrick, Allison; Cappelluti, Nico; Ananna, Tonima Tasnim; Boquien, Médéric; Baloković, Mislav; Civano, Francesca; Coleman, Brandon; Ghosh, Aritra; Kartaltepe, Jeyhan; Koss, Michael; Lamassa, Stephanie; Marchesi, Stefano; Peca, Alessandro; Powell, Meredith; Trakhtenbrot, Benny; Turner, Tracey Jane "The Accretion History of AGN: The Spectral Energy Distributions of X-Ray-luminous Active Galactic Nuclei," *The Astrophysical Journal*, 957, 19, 2023.
- Avison, A.; Fuller, G. A.; Frimpong, N. Asabre; Etoka, S.; Hoare, M.; Jones, B. M.; Peretto, N.; Traficante, A.; Van Der Tak, F.; Pineda, J. E.; Beltrán, M.; Wyrowski, F.; Thompson, M.; Lumsden, S.; Nagy, Z.; Hill, T.; Viti, S.; Fontani, F.; Schilke, P. "Tracing Evolution in Massive Protostellar Objects - I. Fragmentation and emission properties of massive star-forming clumps in a luminosity-limited ALMA sample," *Monthly Notices of the Royal Astronomical Society*, 526, 2278, 2023.
- Aydi, E.; Chomiuk, L.; Mikołajewska, J.; Brink, J.; Metzger, B. D.; Strader, J.; Buckley, D. A. H.; Harvey, E. J.; Holoien, T. W.-S.; Izzo, L.; Kawash, A.; Linford, J. D.; Molaro, P.; Molina, I.; Mróz, P.; Mukai, K.; Orio, M.; Panurach, T.; Senchyna, P.; Shappee, B. J.; Shen, K. J.; Sokolowski, J. L.; Sokolovsky, K. V.; Urquhart, R.; Williams, R. E. "Catching a nova X-ray/UV flash in the visible? Early spectroscopy of the very slow Nova Velorum 2022 (Gaia22alz)," *Monthly Notices of the Royal Astronomical Society*, 524, 1946, 2023.
- Azadi, Mojegan; Wilkes, Belinda; Kuraszkiewicz, Joanna; McDowell, Jonathan; Siebenmorgen, Ralf; Ashby, Matthew; Birkinshaw, Mark; Worrall, Diana; Abrams, Natasha; Barthel, Peter; Fazio, Giovanni G.; Haas, Martin; Hyman, Sóley; Martínez-Galarza, Rafael; Meyer, Eileen T. "Disentangling the AGN and Star formation Contributions to the Radio-X-Ray Emission of Radio-loud Quasars at  $1 < Z < 2$ ," *The Astrophysical Journal*, 945, 145, 2023.
- Bacchini, Cecilia; Mingozi, Matilde; Poggianti, Bianca M.; Moretti, Alessia; Gullieuszik, Marco; Marasco, Antonino; Cervantes Sodi, Bernardo;

- Sánchez-García, Osbaldo; Vulcani, Benedetta; Werle, Ariel; Paladino, Rosita; Radovich, Mario "3D Modeling of the Molecular Gas Kinematics in Optically Selected Jellyfish Galaxies," *The Astrophysical Journal*, 950, 24, 2023.
- Baghel, Janhavi; Kharb, P.; Silpa, S.; Ho, Luis C.; Harrison, C. M. "A polarimetric study of 9 PG quasars with the VLA," *Monthly Notices of the Royal Astronomical Society*, 519, 2773, 2023.
- Baglio, M. C.; Coti Zelati, F.; Campana, S.; Busquet, G.; D'Avanzo, P.; Giarratana, S.; Giroletti, M.; Ambrosino, F.; Crespi, S.; Miraval Zanón, A.; Hou, X.; Li, D.; Li, J.; Wang, P.; Russell, D. M.; Torres, D. F.; Alabarta, K.; Casella, P.; Covino, S.; Bramich, D. M.; De Martino, D.; Méndez, M.; Motta, S. E.; Papitto, A.; Saikia, P.; Vincentelli, F. "Matter ejections behind the highs and lows of the transitional millisecond pulsar PSR J1023+0038," *Astronomy and Astrophysics*, 677, A30, 2023.
- Bahramian, A.; Tremou, E.; Tetarenko, A. J.; Miller-Jones, J. C. A.; Fender, R. P.; Corbel, S.; Williams, D. R. A.; Strader, J.; Carotenuto, F.; Salinas, R.; Kennea, J. A.; Motta, S. E.; Woudt, P. A.; Matthews, J. H.; Russell, T. D. "MAXI J1848-015: The First Detection of Relativistically Moving Outflows from a Globular Cluster X-Ray Binary," *The Astrophysical Journal*, 948, L7, 2023.
- Baidoo, Lerato; Perley, Richard A.; Eilek, Jean; Smirnov, Oleg; Vacca, Valentina; Enßlin, Torsten "A Wideband Polarization Observation of Hydra A with the Jansky Very Large Array," *The Astrophysical Journal*, 955, 16, 2023.
- Baker, Daniel; Briske, Walter; Van Kerkwijk, Marten H.; Van Lieshout, Rik; Pen, Ue-Li "High-resolution VLBI astrometry of pulsar scintillation screens with the  $\theta - \theta$  transform," *Monthly Notices of the Royal Astronomical Society*, 525, 211, 2023.
- Bakx, Tom J. L. C.; Zavala, Jorge A.; Mitsuhashi, Ikki; Treu, Tommaso; Fontana, Adriano; Tadaki, Ken-Ichi; Casey, Caitlin M.; Castellano, Marco; Glazebrook, Karl; Hagimoto, Masato; Ikeda, Ryota; Jones, Tucker; Leethochawalit, Nicha; Mason, Charlotte; Morishita, Takahiro; Nanayakkara, Themiya; Pentericci, Laura; Roberts-Borsani, Guido; Santini, Paola; Serjeant, Stephen; Tamura, Yoichi; Trenti, Michele; Vanzella, Eros "Deep ALMA redshift search of a  $z \sim 12$  GLASS-JWST galaxy candidate," *Monthly Notices of the Royal Astronomical Society*, 519, 5076, 2023.
- Balakrishnan, Vishnu; Freire, Paulo C. C.; Ransom, S. M.; Ridolfi, Alessandro; Barr, E. D.; Chen, W.; Krishnan, Vivek Venkatraman; Champion, D.; Kramer, M.; Gautam, T.; Padmanabh, Prajwal V.; Men, Yunpeng; Abbate, F.; Stappers, B. W.; Stairs, I.; Keane, E.; Possenti, A. "Missing for 20 yr: MeerKAT Redetects the Elusive Binary Pulsar M30B," *The Astrophysical Journal*, 942, L35, 2023.
- Ball, Brianna D.; Kothes, Roland; Rosolowsky, Erik; West, Jennifer; Becker, Werner; Filipović, Miroslav D.; Gaensler, B. M.; Hopkins, Andrew M.; Koribalski, Bärbel; Landecker, Tom; Leahy, Denis; Marvil, Joshua; Sun, Xiaohui; Bufano, Filomena; Carretti, Ettore; Ingallinera, Adriano; Van Eck, Cameron L.; Willis, Tony "A Catalogue of Radio Supernova Remnants and Candidate Supernova Remnants in the EMU/POSSUM Galactic Pilot Field," *Monthly Notices of the Royal Astronomical Society*, 524, 1396, 2023.
- Ballerio, Nicholas P.; Cleaves, L. Ilse; Haworth, Thomas J.; Bally, John; Eisner, Josh A.; Ginsburg, Adam; Boyden, Ryan D.; Fang, Min; Kim, Jinyoung Serena "Isolating Dust and Free-Free Emission in ONC Proplyds with ALMA Band 3 Observations," *The Astrophysical Journal*, 954, 127, 2023.
- Balsalobre-Ruza, O.; De Gregorio-Monsalvo, I.; Lillo-Box, J.; Huéllamo, N.; Ribas, Á.; Benisty, M.; Bae, J.; Facchini, S.; Teague, R. "Tentative co-orbital submillimeter emission within the Lagrangian region L5 of the protoplanet PDS 70 b," *Astronomy and Astrophysics*, 675, A172, 2023.
- Bañados, Eduardo; Schindler, Jan-Torge; Venemans, Bram P.; Connor, Thomas; Decarli, Roberto; Farina, Emanuele Paolo; Mazzucchelli, Chiara; Meyer, Romain A.; Stern, Daniel; Walter, Fabian; Fan, Xiaohui; Hennawi, Joseph F.; Khusanova, Yana; Morrell, Nidia; Nanni, Riccardo; Noirot, Gaël; Pensabene, Antonio; Rix, Hans-Walter; Simon, Joseph; Verdoes Kleijn, Gijs A.; Xie, Zhang-Liang; Yang, Da-Ming; Connor, Andrew "The Pan-STARRS1  $z > 5.6$  Quasar Survey. II. Discovery of 55 Quasars at  $5.6 < z < 6.5$ ," *The Astrophysical Journal Supplement Series*, 265, 29, 2023.
- Bañares-Hernández, Andrés; Castillo, Andrés; Martín Camalich, Jorge; Iorio, Giuliano "Confronting fuzzy dark matter with the rotation curves of nearby dwarf irregular galaxies," *Astronomy and Astrophysics*, 676, A63, 2023.
- Barger, A. J.; Cowie, L. L. "Mapping the Decline with Redshift of Dusty Star-forming Galaxies Using JWST and SCUBA-2," *The Astrophysical Journal*, 956, 95, 2023.
- Barnes, A. T.; Liu, J.; Zhang, Q.; Tan, J. C.; Bigiel, F.; Caselli, P.; Cosentino, G.; Fontani, F.; Henshaw, J. D.; Jiménez-Serra, I.; Kalb, D.-S.; Law, C. Y.; Longmore, S. N.; Parker, R. J.; Pineda, J. E.; Sánchez-Monge, A.; Lim, W.; Wang, K. "Mother of dragons. A massive, quiescent core in the dragon cloud (IRDC G028.37+00.07)," *Astronomy and Astrophysics*, 675, A53, 2023.
- Barnes, Ashley T.; Watkins, Elizabeth J.; Meidt, Sharon E.; Kreckel, Kathryn; Sormani, Mattia C.; Treß, Robin G.; Glover, Simon C. O.; Bigiel, Frank; Chandar, Rupali; Emsellem, Eric; Lee, Janice C.; Leroy, Adam K.; Sandstrom, Karin M.; Schinnerer, Eva; Rosolowsky, Erik; Belfiore, Francesco; Blanc, Guillermo A.; Boquien, Médéric; Brok, Jakob Den; Cao, Yixian; Chevance, Mélanie; Dale, Daniel A.; Egorov, Oleg V.; Eibensteiner, Cosima; Grasha, Kathryn; Groves, Brent; Hassani, Hamid; Henshaw, Jonathan D.; Jeffreson, Sarah; Jiménez-Donaire, María J.; Keller, Benjamin W.; Klessen, Ralf S.; Koch, Eric W.; Kruijssen, J. M. Diederik; Larson, Kirsten L.; Li, Jing; Liu, Daizhong; Lopez, Laura A.; Murphy, Eric J.; Neumann, Lukas; Pety, Jérôme; Pinna, Francesca; Querejeta, Miguel; Renaud, Florent; Saito, Toshiki; Sarbadhikary, Sumit K.; Sardone, Amy; Smith, Rowan J.; Stuber, Sophia K.; Sun, Jiayi; Thilker, David A.; Usero, Antonio; Whitmore, Bradley C.; Williams, Thomas G. "PHANGS-JWST First Results: Multiwavelength View of Feedback-driven Bubbles (the Phantom Voids) across NGC 628," *The Astrophysical Journal*, 944, L22, 2023.
- Barnes, Peter J.; Ryder, Stuart D.; Novak, Giles; Crutcher, Richard M.; Fissel, Laura M.; Pitts, Rebecca L.; Schap, William J., III "SOFIA and ALMA Investigate Magnetic Fields and Gas Structures in Massive Star Formation: The Case of the Masquerading Monster in BYF 73," *The Astrophysical Journal*, 945, 34, 2023.
- Barrufet, L.; Oesch, P. A.; Bouwens, R.; Inami, H.; Sommovigo, L.; Algera, H.; Da Cunha, E.; Aravena, M.; Dayal, P.; Ferrara, A.; Fudamoto, Y.; Gonzalez, V.; Graziani, L.; Hygate, A. P. S.; De Looze, I.; Nanayakkara, T.; Pallottini, A.; Schneider, R.; Stefanon, M.; Topping, M.; Van Der Werf, P. "The ALMA REBELS Survey: The First Infrared Luminosity Function Measurement at  $z \sim 7$ ," *Monthly Notices of the Royal Astronomical Society*, 522, 3926-3934, 2023.
- Bassett, Neil; Rapetti, David; Nhan, Bang D.; Page, Brent; Burns, Jack O.; Pulupa, Marc; Bale, Stuart D. "Constraining a Model of the Radio Sky below 6 MHz Using the Parker Solar Probe/FIELDS Instrument in Preparation for Upcoming Lunar-based Experiments," *The Astrophysical Journal*, 945, 134, 2023.
- Baudry, A.; Wong, K. T.; Etoka, S.; Richards, A. M. S.; Müller, H. S. P.; Herpin, F.; Danilovich, T.; Gray, M. D.; Wallström, S.; Gobrecht, D.; Khouri, T.; Decin, L.; Gottlieb, C. A.; Menten, K. M.; Homan, W.; Millar, T. J.; Montargès, M.; Pimpanuwat, B.; Plane, J. M. C.; Kervella, P. "ATOMIUM: Probing the inner wind of evolved O-rich stars with new, highly excited H<sub>2</sub>O and OH lines," *Astronomy and Astrophysics*, 674, A125, 2023.
- Bayandina, O. S.; Burns, R. A.; Kurtz, S. E.; Moscadelli, L.; Sobolev, A. M.; Stecklum, B.; Val'Tts, I. E. "Nature of continuum emission in the source of the water maser super-flare G25.65+1.04," *Astronomy and Astrophysics*, 673, A60, 2023.
- Bécsy, Bence; Cornish, Neil J.; Meyers, Patrick M.; Kelley, Luke Zoltan; Agazie, Gabriella; Anumalapudi, Akash; Archibald, Anne M.; Arzoumanian, Zaven; Baker, Paul T.; Blecha, Laura; Brazier, Adam; Brook, Paul R.; Burke-Spolaor, Sarah; Casey-Clyde, J. Andrew; Charisi,

## APPENDIX A: PUBLICATIONS

- Maria; Chatterjee, Shami; Chatziioannou, Katerina; Cohen, Tyler; Cordes, James M.; Crawford, Fronefield; Cromartie, H. Thankful; Crowter, Kathryn; Decesar, Megan E.; Demorest, Paul B.; Dolch, Timothy; Ferrara, Elizabeth C.; Fiore, William; Fonseca, Emmanuel; Freedman, Gabriel E.; Garver-Daniels, Nate; Gentile, Peter A.; Glaser, Joseph; Good, Deborah C.; Gültekin, Kayhan; Hazboun, Jeffrey S.; Hourihane, Sophie; Jennings, Ross J.; Johnson, Aaron D.; Jones, Megan L.; Kaiser, Andrew R.; Kaplan, David L.; Kerr, Matthew; Key, Joey S.; Laal, Nima; Lam, Michael T.; Lamb, William G.; W. Lazio, T. Joseph; Lewandowska, Natalia; Littenberg, Tyson B.; Liu, Tingting; Lorimer, Duncan R.; Luo, Jing; Lynch, Ryan S.; Ma, Chung-Pei; Madison, Dustin R.; McEwen, Alexander; Mckee, James W.; McLaughlin, Maura A.; Mckinnon, Natasha; Meyers, Bradley W.; Mingarelli, Chiara M. F.; Mitridate, Andrea; Ng, Cherry; Nice, David J.; Ocker, Stella Koch; Olum, Ken D.; Pennucci, Timothy T.; Perera, Benetge B. P.; Pol, Nihan S.; Radovan, Henri A.; Ransom, Scott M.; Ray, Paul S.; Romano, Joseph D.; Sardesai, Shashwat C.; Schmiedekamp, Ann; Schmiedekamp, Carl; Schmitz, Kai; Shapiro-Albert, Brent J.; Siemens, Xavier; Simon, Joseph; Siwek, Magdalena S.; Sosa Fiscella, Sophia V.; Stairs, Ingrid H.; Stinebring, Daniel R.; Stovall, Kevin; Subobhanan, Abhimanyu; Wiggum, Joseph K.; Taylor, Stephen R.; Turner, Jacob E.; Unal, Caner; Vallisneri, Michele; Van Haasteren, Rutger; Vigeland, Sarah J.; Wahl, Haley M.; Witt, Caitlin A.; Young, Olivia "How to Detect an Astrophysical Nanohertz Gravitational Wave Background," *The Astrophysical Journal*, 959, 9, 2023.
- Bégin, T.; Hlavacek-Larrondo, J.; Rhea, C. L.; Gendron-Marsolais, M.; Mcnamara, B.; Van Weeren, R. J.; Richard-Laferrrière, A.; Guité, L.; Prasow-Émond, M.; Haggard, D. "Extended radio emission in the galaxy cluster MS 0735.6+7421 detected with the Karl G. Jansky Very Large Array," *Monthly Notices of the Royal Astronomical Society*, 519, 767, 2023.
- Behiri, Meriem; Talia, Margherita; Cimatti, Andrea; Lapi, Andrea; Massardi, Marcella; Enia, Andrea; Vignali, Cristian; Bethermin, Matthieu; Faisst, Andreas; Gentile, Fabrizio; Giulietti, Marika; Gruppioni, Carlotta; Pozzi, Francesca; Smolčić, Vernesa; Zamorani, Gianni "Illuminating the Dark Side of Cosmic Star Formation. II. A Second Date with RS-NIRdark Galaxies in COSMOS," *The Astrophysical Journal*, 957, 63, 2023.
- Belfiore, Francesco; Leroy, Adam K.; Williams, Thomas G.; Barnes, Ashley T.; Bigiel, Frank; Boquien, Médéric; Cao, Yixian; Chastenet, Jérémy; Congiu, Enrico; Dale, Daniel A.; Egorov, Oleg V.; Eibensteiner, Cosima; Emsellem, Eric; Glover, Simon C. O.; Groves, Brent; Hassani, Hamid; Klessen, Ralf S.; Kreckel, Kathryn; Neumann, Lukas; Neumann, Justus; Querejeta, Miguel; Rosolowsky, Erik; Sanchez-Blazquez, Patricia; Sandstrom, Karin; Schinnerer, Eva; Sun, Jiayi; Sutter, Jessica; Watkins, Elizabeth J. "Calibrating mid-infrared emission as a tracer of obscured star formation on H II-region scales in the era of JWST," *Astronomy and Astrophysics*, 678, A129, 2023.
- Belladitta, S.; Moretti, A.; Caccianiga, A.; Dallacasa, D.; Spingola, C.; Pedani, M.; Cassarà, L. P.; Bisogni, S. "A powerful (and likely young) radio-loud quasar at  $z = 5.3$ ," *Astronomy and Astrophysics*, 669, A134, 2023.
- Bemis, Ashley R.; Wilson, Christine D. "Does the HCN/CO Ratio Trace the Star-forming Fraction of Gas? I. A Comparison with Analytical Models of Star Formation," *The Astrophysical Journal*, 945, 42, 2023.
- Bendo, G. J.; Urquhart, S. A.; Serjeant, S.; Bakx, T.; Hagimoto, M.; Cox, P.; Neri, R.; Lehnert, M. D.; Dannerbauer, H.; Amvrosiadis, A.; Andreani, P.; Baker, A. J.; Beelen, A.; Berta, S.; Borsato, E.; Buat, V.; Butler, K. M.; Cooray, A.; De Zotti, G.; Dunne, L.; Dye, S.; Eales, S.; Enia, A.; Fan, L.; Gavazzi, R.; González-Nuevo, J.; Harris, A. I.; Herrera, C. N.; Hughes, D. H.; Ismail, D.; Jones, B. M.; Kohno, K.; Krips, M.; Lagache, G.; Marchetti, L.; Massardi, M.; Messias, H.; Negrello, M.; Omont, A.; Pérez-Fournon, I.; Riechers, D. A.; Scott, D.; Smith, M. W. L.; Stanley, F.; Tamura, Y.; Temi, P.; Van Der Werf, P.; Verma, A.; Vlahakis, C.; Weiß, A.; Yang, C.; Young, A. J. "The bright extragalactic ALMA redshift survey (BEARS) - II. Millimetre photometry of gravitational lens candidates," *Monthly Notices of the Royal Astronomical Society*, 522, 2995, 2023.
- Benke, P.; Gabányi, K. É.; Frey, S.; An, T.; Gurvits, L. I.; Kun, E.; Mohan, P.; Paragi, Z.; Ros, E. "From binary to singular: The AGN PSO J334.2028+1.4075 under the high-resolution scope," *Astronomy and Astrophysics*, 677, A1, 2023.
- Bernardo, Reginald Christian; Ng, Kin-Wang "Looking out for the Galileon in the nanohertz gravitational wave sky," *Physics Letters B*, 841, 137939, 2023.
- Bernardo, Reginald Christian; Ng, Kin-Wang "Constraining gravitational wave propagation using pulsar timing array correlations," *Physical Review D*, 107, L101502, 2023.
- Berta, S.; Stanley, F.; Ismail, D.; Cox, P.; Neri, R.; Yang, C.; Young, A. J.; Jin, S.; Dannerbauer, H.; Bakx, T. J. L. C.; Beelen, A.; Weiß, A.; Nanni, A.; Omont, A.; Van Der Werf, P.; Krips, M.; Baker, A. J.; Bendo, G.; Borsato, E.; Buat, V.; Butler, K. M.; Chartab, N.; Cooray, A.; Dye, S.; Eales, S.; Gavazzi, R.; Hughes, D.; Ivson, R. J.; Jones, B. M.; Lehnert, M.; Marchetti, L.; Messias, H.; Negrello, M.; Pérez-Fournon, I.; Riechers, D. A.; Serjeant, S.; Urquhart, S.; Vlahakis, C. "z-GAL: A NOEMA spectroscopic redshift survey of bright Herschel galaxies. III. Physical properties," *Astronomy and Astrophysics*, 678, A28, 2023.
- Béthermin, M.; Accard, C.; Guillaume, C.; Dessauges-Zavadsky, M.; Ibar, E.; Cassata, P.; Devereaux, T.; Faisst, A.; Freundlich, J.; Jones, G. C.; Krajjic, K.; Algera, H.; Amorín, R. O.; Bardelli, S.; Boquien, M.; Buat, V.; Donghia, E.; Dubois, Y.; Ferrara, A.; Fudamoto, Y.; Ginolfi, M.; Guillard, P.; Giallisco, M.; Gruppioni, C.; Gururajan, G.; Hathi, N.; Hayward, C. C.; Koekemoer, A. M.; Lemaux, B. C.; Magdis, G. E.; Molina, J.; Narayanan, D.; Mayer, L.; Pozzi, F.; Rizzo, F.; Romano, M.; Tasca, L.; Theulé, P.; Vergani, D.; Vallini, L.; Zamorani, G.; Zanella, A.; Zucca, E. "The ALMA-ALPINE [CII] survey: Kennicutt-Schmidt relation in four massive main-sequence galaxies at  $z \sim 4.5$ ," *Astronomy and Astrophysics*, 680, L8, 2023.
- Bhandari, Shivani; Gordon, Alexa C.; Scott, Danica R.; Marnoch, Lachlan; Sridhar, Navin; Kumar, Pravir; James, Clancy W.; Qiu, Hao; Bannister, Keith W.; T. Deller, Adam; Eftekhari, Tarraneh; Fong, Wen-Fai; Glowacki, Marcin; Prochaska, J. Xavier; Ryder, Stuart D.; Shannon, Ryan M.; Simha, Sunil "A Nonrepeating Fast Radio Burst in a Dwarf Host Galaxy," *The Astrophysical Journal*, 948, 67, 2023.
- Bhat, N. D. R.; Swainston, N. A.; Mcsweeney, S. J.; Xue, M.; Meyers, B. W.; Kudale, S.; Dai, S.; Tremblay, S. E.; Van Straten, W.; Shannon, R. M.; Smith, K. R.; Sokolowski, M.; Ord, S. M.; Sleep, G.; Williams, A.; Hancock, P. J.; Lange, R.; Tocknell, J.; Johnston-Hollitt, M.; Kaplan, D. L.; Tingay, S. J.; Walker, M. "The Southern-sky MWA Rapid Two-metre (SMART) pulsar survey--II. Survey status, pulsar census, and first pulsar discoveries," *Publications of the Astronomical Society of Australia*, 40, e020, 2023.
- Bhat, N. D. R.; Swainston, N. A.; Mcsweeney, S. J.; Xue, M.; Meyers, B. W.; Kudale, S.; Dai, S.; Tremblay, S. E.; Van Straten, W.; Shannon, R. M.; Smith, K. R.; Sokolowski, M.; Ord, S. M.; Sleep, G.; Williams, A.; Hancock, P. J.; Lange, R.; Tocknell, J.; Johnston-Hollitt, M.; Kaplan, D. L.; Tingay, S. J.; Walker, M. "The Southern-sky MWA Rapid Two-metre (SMART) pulsar survey--I. Survey design and processing pipeline," *Publications of the Astronomical Society of Australia*, 40, e021, 2023.
- Bi, Yan-Chen; Wu, Yu-Mei; Chen, Zu-Cheng; Huang, Qing-Guo "Implications for the supermassive black hole binaries from the NANOGrav 15-year data set," *Science China Physics, Mechanics, and Astronomy*, 66, 120402, 2023.
- Bianchi, Eleonora; Remijan, Anthony; Codella, Claudio; Ceccarelli, Cecilia; Lique, Francois; Spezzano, Silvia; Balucani, Nadia; Caselli, Paola; Herbst, Eric; Podio, Linda; Vastel, Charlotte; Mcguire, Brett "Cyanopolyne Chemistry in the L1544 Prestellar Core: New Insights from GBT Observations," *The Astrophysical Journal*, 944, 208, 2023.
- Bietenholz, Michael F.; Bartel, Norbert; Bauer, Franz E.; Dwarkadas, Vikram V.; Mtshweni, Leon; Orquera-Rojas, Carlos; Ellingsen, Simon; Horiuchi, Shinji; Tzioumis, Anastasios "The bright supernova 1996cr in the circinus galaxy imaged with VLBI: shell structure with complex evolution," *Monthly Notices of the Royal Astronomical Society*, 521, 2239, 2023.

- Biggs, A. D. "A VLA monitoring study of JVAS B1422+231: investigation of time delays and detection of extrinsic variability," *Monthly Notices of the Royal Astronomical Society*, 522, 426, 2023.
- Bihain, Gabriel "Search of nearby resolved neutron stars among optical sources," *Monthly Notices of the Royal Astronomical Society*, 524, 5658, 2023.
- Birkin, Jack E.; Hutchison, Taylor A.; Welch, Brian; Spilker, Justin S.; Aravena, Manuel; Bayliss, Matthew B.; Cathey, Jared; Chapman, Scott C.; Gonzalez, Anthony H.; Gururajan, Gayathri; Hayward, Christopher C.; Khullar, Gourav; Kim, Keunho J.; Mahler, Guillaume; Malkan, Matthew A.; Narayanan, Desika; Olivier, Grace M.; Phadke, Kedar A.; Reuter, Cassie; Rigby, Jane R.; Smith, J. D. T.; Solimano, Manuel; Sulzenauer, Nikolaus; Vieira, Joaquin D.; Vizgan, David; Weiss, Axel "JWST's TEMPLATES for Star Formation: The First Resolved Gas-phase Metallicity Maps of Dust-obscured Star-forming Galaxies at  $z \sim 4$ ," *The Astrophysical Journal*, 958, 64, 2023.
- Biswas, Ayan; Das, Barnali; Chandra, Poonam; Wade, Gregg A.; Shultz, Matthew E.; Cavallaro, Francesco; Petit, Veronique; Woudt, Patrick A.; Alecian, Evelyne "Discovery of magnetospheric interactions in the doubly magnetic hot binary Lupi," *Monthly Notices of the Royal Astronomical Society*, 523, 5155, 2023.
- Bjerkeli, Per; Ramsey, Jon P.; Harsono, Daniel; Plunkett, Adele; Li, Zhi-Yun; Van Der Wiel, Matthijs H. D.; Calcutt, Hannah; Jørgensen, Jes K.; Kristensen, Lars E. "Possible episodic infall towards a compact disk in B335," *Astronomy and Astrophysics*, 677, A62, 2023.
- Blázquez-Sesé, D.; Gómez-Guijarro, C.; Magdis, G. E.; Magnelli, B.; Gobat, R.; Daddi, E.; Franco, M.; Whitaker, K.; Valentino, F.; Adscheid, S.; Schinnerer, E.; Zanella, A.; Xiao, M.; Wang, T.; Liu, D.; Kokorev, V.; Elbaz, D. "The gas mass reservoir of quiescent galaxies at cosmic noon," *Astronomy and Astrophysics*, 674, A166, 2023.
- Boylev, V. V.; Bajkova, A. T. "Determination of the Spiral Pattern Speed in the Galaxy from Three Samples of Stars," *Astronomy Letters*, 49, 110, 2023.
- Böhme, L.; Schwarz, D. J.; De Gasperin, F.; Röttgering, H. J. A.; Williams, W. L. "Matching LOFAR sources across radio bands," *Astronomy and Astrophysics*, 674, A189, 2023.
- Bohn, Thomas; Inami, Hanae; Diaz-Santos, Tanio; Armus, Lee; Linden, S. T.; U, Vivian; Surace, Jason; Larson, Kirsten L.; Evans, Aaron S.; Hoshioka, Shunshi; Lai, Thomas; Song, Yiqing; Mazzarella, Joseph M.; Barcos-Munoz, Loreto; Charmandaris, Vassilis; Howell, Justin H.; Medling, Anne M.; Privon, George C.; Rich, Jeffrey A.; Stierwalt, Sabrina; Aalto, Susanne; Böker, Torsten; Brown, Michael J. I.; Iwasawa, Kazushi; Malkan, Matthew A.; Van Der Werf, Paul P.; Appleton, Philip; Hayward, Christopher C.; Kemper, Francisca; Law, David; Marshall, Jason; Murphy, Eric J.; Sanders, David "GOALS-JWST: NIRC2 and MIRI Imaging of the Circumnuclear Starburst Ring in NGC 7469," *The Astrophysical Journal*, 942, L36, 2023.
- Bonafede, A.; Gitti, M.; La Bella, N.; Biava, N.; Ubertosi, F.; Brunetti, G.; Lusetti, G.; Brienza, M.; Riseley, C. J.; Stuardi, C.; Botteon, A.; Iagnesi, A.; Röttgering, H.; Van Weeren, R. J. "Shock imprints on the radio mini halo in RBS 797," *Astronomy and Astrophysics*, 680, A5, 2023.
- Bonanomi, Francesca; Ciccone, Claudia; Severgnini, Paola; Braitto, Valentina; Vignali, Cristian; Reeves, James N.; Sirressi, Mattia; Montoya Arroyave, Isabel; Della Ceca, Roberto; Ballo, Lucia; Dotti, Massimo "Another X-ray UFO without a momentum-boosted molecular outflow. ALMA CO(1-0) observations of the galaxy pair IRAS 05054+1718," *Astronomy and Astrophysics*, 673, A46, 2023.
- Bonne, L.; Bontemps, S.; Schneider, N.; Simon, R.; Clarke, S. D.; Csengeri, T.; Chambers, E.; Graf, U.; Jackson, J. M.; Klein, R.; Okada, Y.; Tielens, A. G. G. M.; Tiwari, M. "Unveiling the Formation of the Massive DR21 Ridge," *The Astrophysical Journal*, 951, 39, 2023.
- Bonne, Lars; Andersson, B.-G.; Minchin, Robert; Soam, Archana; Yaldae, Joshua; Kulas, Kristin; Karoly, Janik; Knee, Lewis B. G.; Kumar, Siddharth; Roy, Nirupam "High-resolution Observations of H I in the IC 63 Reflection Nebula," *The Astronomical Journal*, 165, 243, 2023.
- Boogaard, Leindert A.; Decarli, Roberto; Walter, Fabian; Weiß, Axel; Popping, Gergö; Neri, Roberto; Aravena, Manuel; Riechers, Dominik; Ellis, Richard S.; Carilli, Chris; Cox, Pierre; Pety, Jérôme "A NOEMA Molecular Line Scan of the Hubble Deep Field North: Improved Constraints on the CO Luminosity Functions and Cosmic Density of Molecular Gas," *The Astrophysical Journal*, 945, 111, 2023.
- Booth, Alice S.; Ilee, John D.; Walsh, Catherine; Kama, Mihkel; Keyte, Luke; Van Dishoeck, Ewine F.; Nomura, Hideko "Sulphur monoxide emission tracing an embedded planet in the HD 100546 protoplanetary disk," *Astronomy and Astrophysics*, 669, A53, 2023.
- Booth, Alice S.; Law, Charles J.; Temmink, Milou; Leemker, Margot; Macías, Enrique "Tracing snowlines and C/O ratio in a planet-hosting disk. ALMA molecular line observations towards the HD 169142 disk," *Astronomy and Astrophysics*, 678, A146, 2023.
- Booth, Mark; Pearce, Tim D.; Krivov, Alexander V.; Wyatt, Mark C.; Dent, William R. F.; Hales, Antonio S.; Lestrade, Jean-François; De Miera, Fernando Cruz-Sáenz; Faramaz, Virginie C.; Löhne, Torsten; Chavez-Dagostino, Miguel "The clumpy structure of Eridani's debris disc revisited by ALMA," *Monthly Notices of the Royal Astronomical Society*, 521, 6180, 2023.
- Borlaff, Alejandro S.; Lopez-Rodriguez, Enrique; Beck, Rainer; Clark, Susan E.; Ntormousi, Evangelia; Tassis, Konstantinos; Martin-Alvarez, Sergio; Tahani, Mehrnoosh; Dale, Daniel A.; Del Moral-Castro, Ignacio; Roman-Duval, Julia; Marcum, Pamela M.; Beckman, John E.; Subramanian, Kandaswamy; Eftekharzadeh, Sarah; Proudfit, Leslie "Extragalactic Magnetism with SOFIA (SALSA Legacy Program). V. First Results on the Magnetic Field Orientation of Galaxies," *The Astrophysical Journal*, 952, 4, 2023.
- Boschin, W.; Girardi, M.; De Grandi, S.; Riva, G.; Feretti, L.; Giovannini, G.; Govoni, F.; Vacca, V. "Optical/X-ray/radio view of Abell 1213: A galaxy cluster with anomalous diffuse radio emission," *Astronomy and Astrophysics*, 672, A199, 2023.
- Boyce, M. M.; Hopkins, A. M.; Riggi, S.; Rudnick, L.; Ramsay, M.; Hale, C. L.; Marvil, J.; Whiting, M. T.; Venkataraman, P.; O'Dea, C. P.; Baum, S. A.; Gordon, Y. A.; Vantyghem, A. N.; Dionysiou, M.; Andermach, H.; Collier, J. D.; English, J.; Koribalski, B. S.; Leahy, D.; Michałowski, M. J.; Safi-Harb, S.; Vaccari, M.; Alexander, E. L.; Cowley, M.; Kapinska, A. D.; Robotham, A. S. G.; Tang, H. "Hydra I: An extensible multi-source-finder comparison and cataloguing tool," *Publications of the Astronomical Society of Australia*, 40, e028, 2023.
- Boyce, M. M.; Hopkins, A. M.; Riggi, S.; Rudnick, L.; Ramsay, M.; Hale, C. L.; Marvil, J.; Whiting, M. T.; Venkataraman, P.; O'Dea, C. P.; Baum, S. A.; Gordon, Y. A.; Vantyghem, A. N.; Dionysiou, M.; Andermach, H.; Collier, J. D.; English, J.; Koribalski, B. S.; Leahy, D.; Michałowski, M. J.; Safi-Harb, S.; Vaccari, M.; Alexander, E. L.; Cowley, M.; Kapinska, A. D.; Robotham, A. S. G.; Tang, H. "Hydra II: Characterisation of Aegean, Caesar, ProFound, PyBDSF, and Selavy source finders," *Publications of the Astronomical Society of Australia*, 40, e027, 2023.
- Boyd, Ryan D.; Eisner, Josh A. "Chemical Modeling of Orion Nebula Cluster Disks: Evidence for Massive, Compact Gas Disks with Interstellar Gas-to-dust Ratios," *The Astrophysical Journal*, 947, 7, 2023.
- Breiding, Peter; Meyer, Eileen T.; Georgopoulos, Markos; Reddy, Karthik; Kollmann, Cassidy E.; Roychowdhury, Agniva "A multiwavelength study of multiple spectral component jets in AGN: testing the IC/CMB model for the large-scale-jet X-ray emission," *Monthly Notices of the Royal Astronomical Society*, 518, 3222, 2023.
- Brienza, M.; Gilli, R.; Prandoni, I.; D'Amato, Q.; Rajpurohit, K.; Calura, F.; Chiaberge, M.; Comastri, A.; Iwasawa, K.; Lanzuisi, G.; Liuzzo, E.; Marchesi, S.; Mignoli, M.; Miley, G.; Norman, C.; Peca, A.; Raciti, M.; Shimwell, T.; Tozzi, P.; Vignali, C.; Vitello, F.; Vito, F. "AGN feedback in an infant galaxy cluster: LOFAR-Chandra view of the giant FR II radio galaxy J103025+052430 at  $z = 1.7$ ," *Astronomy and Astrophysics*, 672, A179, 2023.
- Bright, Joe S.; Rhodes, Lauren; Farah, Wael; Fender, Rob; Van Der Horst, Alexander J.; Leung, James K.; Williams, David R. A.; Anderson,

## APPENDIX A: PUBLICATIONS

- Gemma E.; Atri, Pikky; Deboer, David R.; Giarratana, Stefano; Green, David A.; Heywood, Ian; Lenc, Emil; Murphy, Tara; Pollak, Alexander W.; Premnath, Pranav H.; Scott, Paul F.; Sheikh, Sofia Z.; Siemion, Andrew; Titterton, David J. "Precise measurements of self-absorbed rising reverse shock emission from gamma-ray burst 221009A," *Nature Astronomy*, vol 7, 986, 2023.
- Brightman, Murray; Hameury, Jean-Marie; Lasota, Jean-Pierre; Baldi, Ranieri D.; Bruni, Gabriele; Cann, Jenna M.; Earnshaw, Hannah; Fürst, Felix; Heida, Marianne; Jaodand, Amruta; Lazzarini, Margaret; Middleton, Matthew J.; Walton, Dominic J.; Weaver, Kimberly A. "A New Sample of Transient Ultraluminous X-Ray Sources Serendipitously Discovered by Swift/XRT," *The Astrophysical Journal*, 951, 51, 2023.
- Britzen, Silke; Krishna, Gopal; Kun, Emma; Olivares, Héctor; Pashchenko, Ilya; Jaron, Frédéric; González, Josefa Becerra; Paneque, David "Detection of a Peculiar Drift in the Nuclear Radio Jet of the TeV Blazar Markarian 501," *Universe*, 9, 115, 2023.
- Brown, Michael E.; Butler, Bryan J. "Masses and Densities of Dwarf Planet Satellites Measured with ALMA," *The Planetary Science Journal*, 4, 193, 2023.
- Brown, Toby; Roberts, Ian D.; Thorp, Mallory; Ellison, Sara L.; Zabel, Nikki; Wilson, Christine D.; Bahé, Yannick M.; Bisaria, Dhruv; Bolatto, Alberto D.; Boselli, Alessandro; Chung, Aeree; Cortese, Luca; Catinella, Barbara; Davis, Timothy A.; Jiménez-Donaire, María J.; Lagos, Claudia D. P.; Lee, Bumhyun; Parker, Laura C.; Smith, Rory; Spekkens, Kristine; Stevens, Adam R. H.; Villanueva, Vicente; Watts, Adam B. "VERTICO. VII. Environmental Quenching Caused by the Suppression of Molecular Gas Content and Star Formation Efficiency in Virgo Cluster Galaxies," *The Astrophysical Journal*, 956, 37, 2023.
- Bruno, L.; Botteon, A.; Shimwell, T.; Cuciti, V.; De Gasperin, F.; Brunetti, G.; Dallacasa, D.; Gastaldello, F.; Rossetti, M.; Van Weeren, R. J.; Venturi, T.; Russo, S. A.; Taffoni, G.; Cassano, R.; Biava, N.; Lusetti, G.; Bonafede, A.; Ghizzardi, S.; De Grandi, S. "A three-component giant radio halo: The puzzling case of the galaxy cluster Abell 2142," *Astronomy and Astrophysics*, 678, A133, 2023.
- Bruno, L.; Brunetti, G.; Botteon, A.; Cuciti, V.; Dallacasa, D.; Cassano, R.; Van Weeren, R. J.; Shimwell, T.; Taffoni, G.; Russo, S. A.; Bonafede, A.; Brügggen, M.; Hoang, D. N.; Rottgering, H. J. A.; Tasse, C. "The Planck clusters in the LOFAR sky. II. LoTSS-DR2: Recovering diffuse extended emission with LOFAR," *Astronomy and Astrophysics*, 672, A41, 2023.
- Bruzewski, S.; Schinzel, F. K.; Taylor, G. B. "A Combined Radio Multi-Survey Catalog of Fermi Unassociated Sources," *The Astrophysical Journal*, 943, 51, 2023.
- Bruzewski, S.; Schinzel, F. K.; Taylor, G. B.; Demorest, P.; Frail, D. A.; Kerr, M.; Kumar, P. "Cannonball or Bowling Ball: Proper Motion and Parallax for PSR J0002+6216," *The Astrophysical Journal*, 958, 163, 2023.
- Brzycki, Bryan; Siemion, Andrew P. V.; De Pater, Imke; Cordes, James M.; Gajjar, Vishal; Lacki, Brian; Sheikh, Sofia "On Detecting Interstellar Scintillation in Narrowband Radio SETI," *The Astrophysical Journal*, 952, 46, 2023.
- Bublitz, Jesse; Kastner, Joel H.; Hily-Blant, Pierre; Forveille, Thierry; Santander-García, Miguel; Alcolea, Javier; Bujarrabal, Valentin; Wilner, David J.; Montez, Rodolfo; Aleman, Isabel "Mapping NGC 7027 in New Light: CO+ and HCO+ Emission Reveal Its Photon- and X-Ray-dominated Regions," *The Astrophysical Journal*, 942, 14, 2023.
- Bujarrabal, V.; Alcolea, J.; Castro-Carrizo, A.; Kluska, J.; Sánchez Contreras, C.; Van Winckel, H. "The very compact dust disk in the Red Rectangle," *Astronomy and Astrophysics*, 677, L18, 2023.
- Bulatek, Alyssa; Ginsburg, Adam; Darling, Jeremy; Henkel, Christian; Menten, Karl M. "The 107 GHz Methanol Transition Is a Dasar in G0.253+0.016," *The Astrophysical Journal*, 956, 78, 2023.
- Burns, R. A.; Uno, Y.; Sakai, N.; Blanchard, J.; Rosli, Z.; Orosz, G.; Yonekura, Y.; Tanabe, Y.; Sugiyama, K.; Hirota, T.; Kim, Kee-Tae; Aberfelds, A.; Volvach, A. E.; Bartkiewicz, A.; Caratti O Garatti, A.; Sobolev, A. M.; Stecklum, B.; Brogan, C.; Phillips, C.; Ladeyschikov, D. A.; Johnstone, D.; Surcis, G.; Macleod, G. C.; Linz, H.; Chibueze, J. O.; Brand, J.; Eislöffel, J.; Hyland, L.; Uscanga, L.; Olech, M.; Durjasz, M.; Bayandina, O.; Breen, S.; Ellingsen, S. P.; Van Den Heever, S. P.; Hunter, T. R.; Chen, X. "A Keplerian disk with a four-arm spiral birthing an episodically accreting high-mass protostar," *Nature Astronomy*, 7, 557, 2023.
- Butler, Kirsty M.; Van Der Werf, Paul P.; Omont, Alain; Cox, Pierre "Neutral outflows in high-z QSOs," *Astronomy and Astrophysics*, 674, L5, 2023.
- Butler, Kirsty M.; Van Der Werf, Paul P.; Topkaras, Theodoros; Rybak, Matus; Venemans, Bram P.; Walter, Fabian; Decarli, Roberto "Molecular Outflows in  $z > 6$  Unobscured QSO Hosts Driven by Star Formation," *The Astrophysical Journal*, 944, 134, 2023.
- Byrne, Alex N.; Xue, Ci; Cooke, Ilsa R.; Mccarthy, Michael C.; Mcguire, Brett A. "Astrochemical Modeling of Propargyl Radical Chemistry in TMC-1," *The Astrophysical Journal*, 957, 88, 2023.
- Cabedo, Victoria; Maury, Anaëlle; Girart, Josep Miquel; Padovani, Marco; Hennebelle, Patrick; Houde, Martin; Zhang, Qizhou "Magnetically regulated collapse in the B335 protostar?. II. Observational constraints on gas ionization and magnetic field coupling," *Astronomy and Astrophysics*, 669, A90, 2023.
- Cacciapuoti, L.; Macias, E.; Maury, A. J.; Chandler, C. J.; Sakai, N.; Tychoniec, L.; Viti, S.; Natta, A.; De Simone, M.; Miotello, A.; Codella, C.; Ceccarelli, C.; Podio, L.; Fedele, D.; Johnstone, D.; Shirley, Y.; Liu, B. J.; Bianchi, E.; Zhang, Z. E.; Pineda, J.; Loinard, L.; Ménard, F.; Lebrouilly, U.; Klessen, R. S.; Hennebelle, P.; Molinari, S.; Testi, L.; Yamamoto, S. "FAUST. IX. Multiband, multiscale dust study of L1527 IRS. Evidence for variations in dust properties within the envelope of a class 0/I young stellar object," *Astronomy and Astrophysics*, 676, A4, 2023.
- Cadelano, Mario; Pallanca, Cristina; Dalessandro, Emanuele; Salaris, Maurizio; Mucciarelli, Alessio; Leanza, Silvia; Ferraro, Francesco R.; Lanzoni, Barbara; Rosie Chen, C.-H.; Freire, Paulo C. C.; Heinke, Craig; Ransom, Scott M. "JWST uncovers helium and water abundance variations in the bulge globular cluster NGC 6440," *Astronomy and Astrophysics*, 679, L13, 2023.
- Calahan, Jenny K.; Bergin, Edwin A.; Bosman, Arthur D.; Rich, Evan A.; Andrews, Sean M.; Bergner, Jennifer B.; Cleeves, L. Ilse; Guzmán, Viviana V.; Huang, Jane; Ilee, John D.; Law, Charles J.; Le Gal, Romane; Öberg, Karin I.; Teague, Richard; Walsh, Catherine; Wilner, David J.; Zhang, Ke "UV-driven chemistry as a signpost of late-stage planet formation," *Nature Astronomy*, 7, 49, 2023.
- Callanan, Daniel; Longmore, Steven N.; Battersby, Cara; Hatchfield, H. Perry; Walker, Daniel L.; Henshaw, Jonathan; Keto, Eric; Barnes, Ashley; Ginsburg, Adam; Kauffmann, Jens; Kruijssen, J. M. Diederik; Lu, Xing; Mills, Elisabeth A. C.; Pillai, Thushara; Zhang, Qizhou; Bally, John; Butterfield, Natalie; Contreras, Yanett A.; Ho, Luis C.; Immer, Katharina; Johnston, Katharine G.; Ott, Juergen; Patel, Nimesh; Tolls, Volker "CMZoom III: Spectral Line Data Release," *Monthly Notices of the Royal Astronomical Society*, 520, 4760, 2023.
- Callingham, J. R.; Shimwell, T. W.; Vedantham, H. K.; Bassa, C. G.; O'Sullivan, S. P.; Yiu, T. W. H.; Bloor, S.; Best, P. N.; Hardcastle, M. J.; Haverkorn, M.; Kavanagh, R. D.; Lamy, L.; Pope, B. J. S.; Röttgering, H. J. A.; Schwarz, D. J.; Tasse, C.; Van Weeren, R. J.; White, G. J.; Zarka, P.; Bomans, D. J.; Bonafede, A.; Bonato, M.; Botteon, A.; Brügggen, M.; Chyży, K. T.; Drabent, A.; Emig, K. L.; Gloudemans, A. J.; Gürkan, G.; Hajduk, M.; Hoang, D. N.; Hoefl, M.; Iacobelli, M.; Kadler, M.; Kunert-Bajraszewska, M.; Mingo, B.; Morabito, L. K.; Nair, D. G.; Pérez-Torres, M.; Ray, T. P.; Riseley, C. J.; Rowlinson, A.; Shulevski, A.; Sweijen, F.; Timmerman, R.; Vaccari, M.; Zheng, J. "V-LoTSS: The circularly polarised LOFAR Two-metre Sky Survey," *Astronomy and Astrophysics*, 670, A124, 2023.
- Calura, Francesco; Palla, Marco; Morselli, Laura; Spitoni, Emanuele; Casasola, Viviana; Verma, Kuldeep; Enia, Andrea; Meneghetti, Massimo; Bianchi, Simone; Pozzi, Francesca; Gruppioni, Carlotta "A Bayesian chemical evolution model of the DustPedia galaxy M74," *Monthly Notices of the Royal Astronomical Society*, 523, 2351, 2023.
- Calzetti, Daniela; Linden, Sean T.; Mcquaid, Timothy; Messa, Matteo; Ji, Zhiyuan; Krumholz, Mark R.; Adamo, Angela; Elmegreen, Bruce; Grasha, Kathryn; Johnson, Kelsey E.; Sabbi, Elena; Smith, Linda J.;

- Bajaj, Varun "Dust-buried Compact Sources in the Dwarf Galaxy NGC 4449," *The Astrophysical Journal*, 946, 1, 2023.
- Camarca, Maria; De Kleer, Katherine; Butler, Bryan; Akins, Alex B.; Thelen, Alexander; De Pater, Imke; Gurwell, Mark A.; Moullet, Arielle "Thermal Properties of the Leading Hemisphere of Callisto Inferred from ALMA Observations," *The Planetary Science Journal*, 4, 142, 2023.
- Cameron, A. D.; Bailes, M.; Champion, D. J.; Freire, P. C. C.; Kramer, M.; Mclaughlin, M. A.; Ng, C.; Possenti, A.; Ridolfi, A.; Tauris, T. M.; Wahl, H. M.; Wex, N. "New constraints on the kinematic, relativistic, and evolutionary properties of the PSR J1757-1854 double neutron star system," *Monthly Notices of the Royal Astronomical Society*, 523, 5064, 2023.
- Camps-Fariña, A.; Sánchez-Blázquez, P.; Roca-Fàbrega, S.; Sánchez, S. F. "Measuring the physical imprints of gas flows in galaxies. I. Accretion rate histories," *Astronomy and Astrophysics*, 678, A65, 2023.
- Candini, S.; Brienza, M.; Bonafede, A.; Rajpurohit, K.; Biava, N.; Murgia, M.; Loi, F.; Van Weeren, R. J.; Vazza, F. "New filamentary remnant radio emission and duty cycle constraints in the radio galaxy NGC 6086," *Astronomy and Astrophysics*, 677, A4, 2023.
- Cao, Yixian; Wong, Tony; Bolatto, Alberto D.; Leroy, Adam K.; Rosolowsky, Erik; Utomo, Dyas; Sánchez, Sebastián F.; Barrera-Ballesteros, Jorge K.; Levy, Rebecca C.; Colombo, Dario; Blitz, Leo; Vogel, Stuart N.; Puschnig, Johannes; Villanueva, Vicente; Rubio, Monica "The EDGE-CALIFA Survey: Spatially Resolved 13CO(1-0) Observations and Variations in 12CO(1-0)/13CO(1-0) in Nearby Galaxies on Kiloparsec Scales," *The Astrophysical Journal Supplement Series*, 268, 3, 2023.
- Capetti, A.; Brienza, M. "The LOFAR view of massive early-type galaxies: Transition from radio AGN to host emission," *Astronomy and Astrophysics*, 676, A102, 2023.
- Carnerero, Maria I.; Raiteri, Claudia M.; Rimoldini, Lorenzo; Busonero, Deborah; Licata, Enrico; Mowlavi, Nami; Leconte-Taïbi, Isabelle; Aудар, Marc; Holl, Berry; Gavras, Panagiotis; Nienartowicz, Krzysztof; Jevardat De Fombelle, Grégory; Carballo, Ruth; Clementini, Gisella; Delchambre, Ludovic; Klioner, Sergei; Lattanzi, Mario G.; Eyer, Laurent "Gaia Data Release 3. The first Gaia catalogue of variable AGN," *Astronomy and Astrophysics*, 674, A24, 2023.
- Carrasco, Javier; Valenzuela, Daniel; Falcón, Claudio; Finger, Ricardo; Mena, Fausto Patricio "The Effect of Complex Dispersion and Characteristic Impedance on the Gain of Superconducting Traveling-Wave Kinetic Inductance Parametric Amplifiers," *IEEE Transactions on Applied Superconductivity*, 33, 3243464, 2023.
- Carrión-González, Óscar; Moreno, Raphael; Lellouch, Emmanuel; Cavalié, Thibault; Guerlet, Sandrine; Milcareck, Gwenaél; Spiga, Aymeric; Clément, Noé; Leconte, Jérémy "Doppler wind measurements in Neptune's stratosphere with ALMA," *Astronomy and Astrophysics*, 674, L3, 2023.
- Casassus, Simon; Cieza, Lucas; Cárcamo, Miguel; Ribas, Álvaro; Christiaens, Valentin; Rodríguez-Jiménez, Abigali; Arce-Tord, Carla; Bhowmik, Trisha; Chavan, Prachi; González-Ruilova, Camilo; Martínez-Brunner, Rafael "Azimuthal temperature variations in ISO-Oph 2 from multifrequency ALMA observations," *Monthly Notices of the Royal Astronomical Society*, 526, 1545, 2023.
- Castillo, Marta Frias; Hodge, Jacqueline; Rybak, Matus; Van Der Werf, Paul; Smail, Ian; Birkin, Jack E.; Chen, Chian-Chou; Chapman, Scott C.; Hill, Ryley; Lagos, Claudia Del P.; Liao, Cheng-Lin; Da Cunha, Elisabete; Rivera, Gabriela Calistro; Chen, Jianhang; Jiménez-Andrade, E. F.; Murphy, Eric J.; Scott, Douglas; Swinbank, A. M.; Walter, Fabian; Ivison, R. J.; Dannerbauer, Helmut "VLA Legacy Survey of Molecular Gas in Massive Star-forming Galaxies at High Redshift," *The Astrophysical Journal*, 945, 128, 2023.
- Cataldi, Gianni; Aikawa, Yuri; Iwasaki, Kazunari; Marino, Sebastian; Brandeker, Alexis; Hales, Antonio; Henning, Thomas; Higuchi, Aya E.; Hughes, A. Meredith; Janson, Markus; Kral, Quentin; Matrà, Luca; Moór, Attila; Olofsson, Göran; Redfield, Seth; Roberge, Aki "Primordial or Secondary? Testing Models of Debris Disk Gas with ALMA," *The Astrophysical Journal*, 951, 111, 2023.
- Cavalié, T.; Rezac, L.; Moreno, R.; Lellouch, E.; Fouchet, T.; Benmahi, B.; Greathouse, T. K.; Sinclair, J. A.; Hue, V.; Hartogh, P.; Dobrijevic, M.; Carrasco, N.; Perrin, Z. "Evidence for auroral influence on Jupiter's nitrogen and oxygen chemistry revealed by ALMA," *Nature Astronomy*, 7, 1048, 2023.
- Cesaroni, R.; Moscadelli, L.; Caratti O Garatti, A.; Eislöffel, J.; Fedriani, R.; Neri, R.; Ray, T.; Sanna, A.; Stecklum, B. "Radio outburst from a massive (proto)star. II. A portrait in space and time of the expanding radio jet from S255IR NIRS 3," *Astronomy and Astrophysics*, 680, A110, 2023.
- Chakraborty, Avinanda; Chatterjee, Suchetana; Lacy, Mark; Roy, Soumya; Roy, Samrat; Kar Chowdhury, Rudrani "Cosmological Simulations of Galaxy Groups and Clusters. III. Constraining Quasar Feedback Models with the Atacama Large Millimeter Array," *The Astrophysical Journal*, 954, 8, 2023.
- Chamani, Wara; Savolainen, Tuomas; Ros, Eduardo; Kovalev, Yuri Y.; Wiik, Kaj; Lähteenmäki, Anne; Tornikoski, Merja; Tammi, Joni "Time variability of the core-shift effect in the blazar 3C 454.3," *Astronomy and Astrophysics*, 672, A130, 2023.
- Chamma, Mohammed A.; Rajabi, Fereshteh; Kumar, Aishwarya; Houde, Martin "A broad survey of spectro-temporal properties from FRB 20121102A," *Monthly Notices of the Royal Astronomical Society*, 522, 3036, 2023.
- Chastain, S. I.; Van Der Horst, A. J.; Rowlinson, A.; Rhodes, L.; Andersson, A.; Diretse, R.; Fender, R. P.; Woudt, P. A. "Commensal transient searches in eight short gamma-ray burst fields," *Monthly Notices of the Royal Astronomical Society*, 526, 1888, 2023.
- Chastenet, Jérémy; Sutter, Jessica; Sandstrom, Karin; Belfiore, Francesco; Egorov, Oleg V.; Larson, Kirsten L.; Leroy, Adam K.; Liu, Daizhong; Rosolowsky, Erik; Thilker, David A.; Watkins, Elizabeth J.; Williams, Thomas G.; Barnes, Ashley. T.; Bigiel, F.; Boquien, Médéric; Chevance, Mélanie; Dale, Daniel A.; Kruijssen, J. M. Diederik; Emsellem, Eric; Grasha, Kathryn; Groves, Brent; Hassani, Hamid; Hughes, Annie; Kreckel, Kathryn; Meidt, Sharon E.; Pan, Hsi-An; Querejeta, Miguel; Schinnerer, Eva; Whitcomb, Cory M. "PHANGS-JWST First Results: Measuring Polycyclic Aromatic Hydrocarbon Properties across the Multiphase Interstellar Medium," *The Astrophysical Journal*, 944, L12, 2023.
- Chastenet, Jérémy; Sutter, Jessica; Sandstrom, Karin; Belfiore, Francesco; Egorov, Oleg V.; Larson, Kirsten L.; Leroy, Adam K.; Liu, Daizhong; Rosolowsky, Erik; Thilker, David A.; Watkins, Elizabeth J.; Williams, Thomas G.; Barnes, Ashley. T.; Bigiel, Frank; Boquien, Médéric; Chevance, Mélanie; Chiang, I-Da; Dale, Daniel A.; Kruijssen, J. M. Diederik; Emsellem, Eric; Grasha, Kathryn; Groves, Brent; Hassani, Hamid; Hughes, Annie; Kreckel, Kathryn; Meidt, Sharon E.; Rickards Vaught, Ryan J.; Sardone, Amy; Schinnerer, Eva "PHANGS-JWST First Results: Variations in PAH Fraction as a Function of ISM Phase and Metallicity," *The Astrophysical Journal*, 944, L11, 2023.
- Chavan, Kshitij; Dabhade, Pratik; Saikia, D. J. "A giant radio galaxy with three cycles of episodic jet activity from LoTSS DR2," *Monthly Notices of the Royal Astronomical Society*, 525, L87, 2023.
- Chen, Bo-Yan; Bower, Geoffrey C.; Dexter, Jason; Markoff, Sera; Ridenour, Anthony; Gurwell, Mark A.; Rao, Ramprasad; Wallström, Sofia H. J. "Testing the Linear Relationship between Black Hole Mass and Variability Timescale in Low-luminosity AGNs at Submillimeter Wavelengths," *The Astrophysical Journal*, 951, 93, 2023.
- Chen, Ge; Ravi, Vikram; Hallinan, Gregg W. "A Comprehensive Observational Study of the FRB 121102 Persistent Radio Source," *The Astrophysical Journal*, 958, 185, 2023.
- Chen, Guangwen; Bendo, George J.; Fuller, Gary A.; Henkel, Christian; Kong, Xu "Star formation in the centre of NGC 1808 as observed by ALMA," *Monthly Notices of the Royal Astronomical Society*, 525, 3645, 2023.
- Chen, Jianhang; Ivison, R. J.; Zwaan, Martin A.; Klitsch, Anne; Péroux, Céline; Lovell, Christopher C.; Lagos, Claudia Del P.; Biggs, Andrew D.; Bollo, Victoria "ALMACAL. XI. Over-densities as signposts for proto-clusters? A

## APPENDIX A: PUBLICATIONS

- cautionary tale," *Astronomy and Astrophysics*, 675, L10, 2023.
- Chen, Jianhang; Ivison, R. J.; Zwaan, Martin A.; Smail, Ian; Klitsch, Anne; Péroux, Céline; Popping, Gergő; Biggs, Andrew D.; Szakacs, Roland; Hamanowicz, Aleksandra; Lagos, Claudia "ALMACAL IX: Multiband ALMA survey for dusty star-forming galaxies and the resolved fractions of the cosmic infrared background," *Monthly Notices of the Royal Astronomical Society*, 518, 1378, 2023.
- Chen, Jianxing; Cadelano, Mario; Pallanca, Cristina; Ferraro, Francesco R.; Lanzoni, Barbara; Istrate, Alina G.; Burgay, Marta; Freire, Paulo C. C.; Gautam, Tasha; Possenti, Andrea; Ridolfi, Alessandro "A Young White Dwarf Orbiting PSR J1835-3259B in the Bulge Globular Cluster NGC 6652," *The Astrophysical Journal*, 948, 84, 2023.
- Chen, Ming-Tang; Asada, Keiichi; Matsushita, Satoki; Raffin, Philippe; Inoue, Makoto; Ho, Paul T. P.; Han, Chih-Chiang; Kubo, Derek; Norton, Timothy; Patel, Nimesh A.; Nystrom, George; Huang, Chih-Wei L.; Martin-Cocher, Pierre; Yi Koay, Jun; Romero-Cañizales, Cristina; Liu, Ching-Tang; Huang, Teddy; Liu, Kuan-Yu; Wei, Tashun; Chang, Shu-Hao; Chilson, Ryan; Oshiro, Peter; Jiang, Homin; Li, Chao-Te; Bower, Geoffrey; Shaw, Paul; Nishioka, Hiroaki; Koch, Patrick M.; Chen, Chung-Cheng; Srinivasan, Ranjani; Rao, Ramprasad; Snow, William; Jinchi, Hao; Han, Kuo-Chang; Chang, Song-Chu; Lu, Li-Ming; Ogawa, Hideo; Kimura, Kimihiro; Hasegawa, Yutaka; Pu, Hung-Yi; Koyama, Shoko; Nakamura, Masanori; Bintley, Daniel; Walther, Craig; Friberg, Per; Dempsey, Jessica; Sriharan, T. K.; Srikanth, Sivasankaran; Doeleman, Sheperd S.; Brissenden, Roger; Algaba Marcos, Juan-Carlos; Jeter, Britt; Kuo, Cheng-Yu; Park, Jongho "The Greenland Telescope-Construction, Commissioning, and Operations in Pituffik," *Publications of the Astronomical Society of the Pacific*, 135, 95001, 2023.
- Chen, Sina; Laor, Ari; Behar, Ehud; Baldi, Ranieri D.; Gelfand, Joseph D. "The radio emission in radio-quiet quasars: the VLBA perspective," *Monthly Notices of the Royal Astronomical Society*, 525, 164, 2023.
- Chen, W.; Freire, P. C. C.; Ridolfi, A.; Barr, E. D.; Stappers, B.; Kramer, M.; Possenti, A.; Ransom, S. M.; Levin, L.; Breton, R. P.; Burgay, M.; Camilo, F.; Buchner, S.; Champion, D. J.; Abbate, F.; Krishnan, V. Venkatraman; Padmanabh, P. V.; Gautam, T.; Vleeschower, L.; Geyer, M.; Grießmeier, J.-M.; Men, Y. P.; Balakrishnan, V.; Bezuidenhout, M. C. "MeerKAT discovery of 13 new pulsars in Omega Centauri," *Monthly Notices of the Royal Astronomical Society*, 520, pp.3847-3856, 2023.
- Chen, Wen; Zhang, Bo; Zhang, Jingdong; Yang, Jun; Xu, Shuangjing; Sun, Yan; Mai, Xiaofeng; Shu, Fengchun; Wang, Min "VLBI Astrometry of radio stars to link radio and optical celestial reference frames. I. HD 199178 & AR Lacertae," *Monthly Notices of the Royal Astronomical Society*, 524, 5357, 2023.
- Chen, Y.; Van Gelder, M. L.; Nazari, P.; Brogan, C. L.; Van Dishoeck, E. F.; Linnartz, H.; Jørgensen, J. K.; Hunter, T. R.; Wilkins, O. H.; Blake, G. A.; Caselli, P.; Chuang, K.-J.; Codella, C.; Cooke, I.; Drozdovskaya, M. N.; Garrod, R. T.; Ioppolo, S.; Jin, M.; Kulterer, B. M.; Ligterink, N. F. W.; Lipnicky, A.; Loomis, R.; Rachid, M. G.; Spezzano, S.; Mcguire, B. A. "CoCCoA: Complex Chemistry in hot Cores with ALMA. Selected oxygen-bearing species," *Astronomy and Astrophysics*, 678, A137, 2023.
- Chen, Yongyun; Gu, Qiusheng; Fan, Junhui; Yu, Xiaoling; Ding, Nan; Guo, Xiaotong; Xiong, Dingrong "Jet power extracted from ADAFs and the application to Fermi BL Lacertae objects," *Monthly Notices of the Royal Astronomical Society*, 526, 4079, 2023.
- Chen, Yu-Ching; Liu, Xin; Foord, Adi; Shen, Yue; Oguri, Masamune; Chen, Nianyi; Di Matteo, Tiziana; Holgado, Miguel; Hwang, Hsiang-Chih; Zakamska, Nadia "A close quasar pair in a disk-disk galaxy merger at  $z = 2.17$ ," *Nature*, 616, 45, 2023.
- Chen, Yu-Ching; Liu, Xin; Lazio, Joseph; Breiding, Peter; Burke-Spolaor, Sarah; Hwang, Hsiang-Chih; Shen, Yue; Zakamska, Nadia L. "Varstrometry for Off-nucleus and Dual Sub-kiloparsec Active Galactic Nuclei (VODKA): Very Long Baseline Array Searches for Dual or Off-nucleus Quasars and Small-scale Jets," *The Astrophysical Journal*, 958, 29, 2023.
- Chen, Yuguang; Jones, Tucker; Sanders, Ryan; Fadda, Dario; Sutter, Jessica; Minchin, Robert; Huntzinger, Erin; Senchyna, Peter; Stark, Daniel; Spilker, Justin; Weiner, Benjamin; Roberts-Borsani, Guido "Accurate oxygen abundance of interstellar gas in Mrk 71 from optical and infrared spectra," *Nature Astronomy*, 7, 771-778, 2023.
- Cheng, Cheng; Huang, Jia-Sheng; Smail, Ian; Yan, Haojing; Cohen, Seth H.; Jansen, Rolf A.; Windhorst, Rogier A.; Ma, Zhiyuan; Koekemoer, Anton; Willmer, Christopher N. A.; Willner, S. P.; Diego, Jose M.; Frye, Brenda; Conzelice, Christopher J.; Ferreira, Leonardo; Petric, Andreea; Yun, Min; Gim, Hansung B.; Polletta, Maria Del Carmen; Duncan, Kenneth J.; Holwerda, Benne W.; Röttgering, Huub J. A.; Honor, Rachel; Hathi, Nimish P.; Kamienski, Patrick S.; Adams, Nathan J.; Coe, Dan; Broadhurst, Tom; Summers, Jake; Tompkins, Scott; Driver, Simon P.; Groggin, Norman A.; Marshall, Madeline A.; Pirzkal, Nor; Robotham, Aaron; Ryan, Russell E. "JWST's PEARLS: A JWST/NIRCam View of ALMA Sources," *The Astrophysical Journal*, 942, L19, 2023.
- Cheng, Xiaopeng; An, Tao; Wang, Ailing; Jaiswal, Sumit "High-Frequency and High-Resolution VLBI Observations of GHz Peaked Spectrum Objects," *Galaxies*, 11, 42, 2023.
- Cheng, Xiaopeng; Yang, Jun; Zhao, Guangyao-Yao; Sohn, Bong Won; Taehyun, Jung; Li, Xiaofeng "Toward Microarcsecond Astrometry for the Innermost Wobbling Jet of the BL Lacertae Object OJ 287," *The Astrophysical Journal*, 955, L30, 2023.
- Chiang, I-Da; Hirashita, Hiroyuki; Chastenet, Jérémy; Koch, Eric W.; Leroy, Adam K.; Rosolowsky, Erik; Sandstrom, Karin M.; Sardone, Amy; Sun, Jiayi; Williams, Thomas G. "Kpc-scale properties of dust temperature in terms of dust mass and star formation activity," *Monthly Notices of the Royal Astronomical Society*, 520, 5506, 2023.
- Choi, Woora; Liu, Lijie; Bureau, Martin; Cappellari, Michele; Davis, Timothy A.; Gensior, Jindra; Liang, Fu-Heng; Lu, Anan; Williams, Thomas G.; Chung, Aeree "WISDOM Project - XV. Giant molecular clouds in the central region of the barred spiral galaxy NGC 5806," *Monthly Notices of the Royal Astronomical Society*, 522, 4078, 2023.
- Chworowsky, Katherine; Finkelstein, Steven L.; Spilker, Justin S.; Leung, Gene C. K.; Bagley, Micaela B.; Casey, Caitlin M.; Gronwall, Cary; Jogee, Sharda; Larson, Rebecca L.; Papovich, Casey; Somerville, Rachel S.; Stevans, Matthew; Wold, Isak G. B.; Yung, L. Y. Aaron "ALMA 1.1 mm Observations of a Conservative Sample of High-redshift Massive Quiescent Galaxies in SHELA," *The Astrophysical Journal*, 951, 49, 2023.
- Ciesla, L.; Gómez-Guijarro, C.; Buat, V.; Elbaz, D.; Jin, S.; Béthermin, M.; Daddi, E.; Franco, M.; Inami, H.; Magdis, G.; Magnelli, B.; Xiao, M. "GOODS-ALMA 2.0: Last gigayear star formation histories of the so-called starbursts within the main sequence," *Astronomy and Astrophysics*, 672, A191, 2023.
- Clark, C. J.; Breton, R. P.; Barr, E. D.; Burgay, M.; Thongmearkom, T.; Nieder, L.; Buchner, S.; Stappers, B.; Kramer, M.; Becker, W.; Mayer, M.; Phosrisom, A.; Ashok, A.; Bezuidenhout, M. C.; Calore, F.; Cognard, I.; Freire, P. C. C.; Geyer, M.; Grießmeier, J.-M.; Karuppusamy, R.; Levin, L.; Padmanabh, P. V.; Possenti, A.; Ransom, S.; Serylak, M.; Venkatraman Krishnan, V.; Vleeschower, L.; Behrend, J.; Champion, D. J.; Chen, W.; Horn, D.; Keane, E. F.; Künkel, L.; Men, Y.; Ridolfi, A.; Dhillon, V. S.; Marsh, T. R.; Papa, M. A. "The TRAPUM L-band survey for pulsars in Fermi-LAT gamma-ray sources," *Monthly Notices of the Royal Astronomical Society*, 519, 5590, 2023.
- Clark, C. J.; Kerr, M.; Barr, E. D.; Bhattacharyya, B.; Breton, R. P.; Bruel, P.; Camilo, F.; Chen, W.; Cognard, I.; Cromartie, H. T.; Deneva, J.; Dhillon, V. S.; Guillemot, L.; Kennedy, M. R.; Kramer, M.; Lyne, A. G.; Mata Sánchez, D.; Nieder, L.; Phillips, C.; Ransom, S. M.; Ray, P. S.; Roberts, M. S. E.; Roy, J.; Smith, D. A.; Spiewak, R.; Stappers, B. W.; Tabassum, S.; Theureau, G.; Voisin, G. "Neutron star mass estimates from gamma-ray eclipses in spider millisecond pulsar binaries," *Nature Astronomy*, vol 7, 451, 2023.
- Cohn, Jonathan H.; Curliss, Maeve; Walsh, Jonelle L.; Kabasares, Kyle M.; Boizelle, Benjamin D.; Barth, Aaron J.; Gebhardt, Karl; Gültekin, Kayhan;



- Yildirim, Akin; Buote, David A.; Darling, Jeremy; Baker, Andrew J.; Ho, Luis C. "ALMA Gas-dynamical Mass Measurement of the Supermassive Black Hole in the Red Nugget Relic Galaxy PGC 11179," *The Astrophysical Journal*, 958, 186, 2023.
- Colina, L.; Crespo Gómez, A.; Álvarez-Márquez, J.; Bik, A.; Walter, F.; Boogaard, L.; Labiano, A.; Peissker, F.; Pérez-González, P.; Östlin, G.; Greve, T. R.; Nørgaard-Nielsen, H. U.; Wright, G.; Alonso-Herrero, A.; Azollini, R.; Caputi, K. I.; Dicken, D.; García-Marín, M.; Hjorth, J.; Ilbert, O.; Kendrew, S.; Pye, J. P.; Tikkanen, T.; Van Der Werf, P.; Costantin, L.; Iani, E.; Gillman, S.; Jermann, I.; Langeroodi, D.; Moutard, T.; Rinaldi, P.; Topinka, M.; Van Dishoeck, E. F.; Güdel, M.; Henning, Th.; Lagage, P. O.; Ray, T.; Vandenbussche, B. "Uncovering the stellar structure of the dusty star-forming galaxy GN20 at  $z = 4.055$  with MIRI/JWST," *Astronomy and Astrophysics*, 673, L6, 2023.
- Combes, F.; Gupta, N.; Muller, S.; Balashev, S.; Deka, P. P.; Emig, K. L.; Klöckner, H.-R.; Klutse, D.; Knowles, K.; Mohapatra, A.; Momjian, E.; Noterdaeme, P.; Petitjean, P.; Salas, P.; Srikanand, R.; Wagenveld, J. D. "PKS 1413+135: OH and H I at  $z = 0.247$  with MeerKAT," *Astronomy and Astrophysics*, 671, A43, 2023.
- Cook, Amanda M.; Bhardwaj, Mohit; Gaensler, B. M.; Scholz, Paul; Eadie, Gwendolyn M.; Hill, Alex S.; Kaspi, Victoria M.; Masui, Kiyoshi W.; Curtin, Alice P.; Dong, Fengqiu Adam; Fonseca, Emmanuel; Herrera-Martin, Antonio; Kaczmarek, Jane; Lanman, Adam E.; Lazda, Mattias; Leung, Calvin; Meyers, Bradley W.; Michilli, Daniele; Pandhi, Ayush; Pearlman, Aaron B.; Pleunis, Ziggy; Ransom, Scott; Rahman, Mubdi; Sand, Ketan R.; Shin, Kaitlyn; Smith, Kendrick; Stairs, Ingrid; Stenning, David C. "An FRB Sent Me a DM: Constraining the Electron Column of the Milky Way Halo with Fast Radio Burst Dispersion Measures from CHIME/FRB," *The Astrophysical Journal*, 946, 58, 2023.
- Cooke, Ilsa R.; Xue, Ci; Changala, P. Bryan; Shay, Hannah Toru; Byrne, Alex N.; Tang, Qi Yu; Fried, Zachary T. P.; Kelvin Lee, Kin Long; Loomis, Ryan A.; Lamberts, Thanja; Remijan, Anthony; Burkhardt, Andrew M.; Herbst, Eric; McCarthy, Michael C.; Mcguire, Brett A. "Detection of Interstellar E-1-cyano-1,3-butadiene in GOTHAM Observations of TMC-1," *The Astrophysical Journal*, 948, 133, 2023.
- Cordiner, M. A.; Roth, N. X.; Milam, S. N.; Villanueva, G. L.; Bockelée-Morvan, D.; Remijan, A. J.; Charnley, S. B.; Biver, N.; Lis, D. C.; Qi, C.; Bonev, B. P.; Crovisier, J.; Boissier, J. "Gas Sources from the Coma and Nucleus of Comet 46P/Wirtanen Observed Using ALMA," *The Astrophysical Journal*, 953, 59, 2023.
- Cordun, C. M.; Timmerman, R.; Miley, G. K.; Van Weeren, R. J.; Sweijen, F.; Morabito, L. K.; Röttgering, H. J. A. "VLBI imaging of high-redshift galaxies and protoclusters at low radio frequencies with the International LOFAR Telescope," *Astronomy and Astrophysics*, 676, A29, 2023.
- Corongiu, A.; Venkatraman Krishnan, V.; Freire, P. C. C.; Kramer, M.; Possenti, A.; Geyer, M.; Ridolfi, A.; Abbate, F.; Bailes, M.; Barr, E. D.; Balakrishnan, V.; Buchner, S.; Champion, D. J.; Chen, W.; Hugo, B. V.; Karastergiou, A.; Lyne, A. G.; Manchester, R. N.; Padmanabh, P. V.; Parthasarathy, A.; Ransom, S. M.; Sarkissian, J. M.; Serylak, M.; Van Straten, W. "PSR J1910-5959A: A rare gravitational laboratory for testing white dwarf models," *Astronomy and Astrophysics*, 671, A72, 2023.
- Corsi, Alessandra; Ho, Anna Y. Q.; Cenko, S. Bradley; Kulkarni, Shrinivas R.; Anand, Shreya; Yang, Sheng; Sollerman, Jesper; Srinivasaragavan, Gokul P.; Ormand, Conor M. B.; Balasubramanian, Arvind; Frail, Dale A.; Fremling, Christoffer; Perley, Daniel A.; Yao, Yuhan; Dahiwal, Aishwarya S.; De, Kishalay; Dugas, Alison; Hankins, Matthew; Jencson, Jacob; Kasliwal, Mansi M.; Tzanidakis, Anastasios; Bellm, Eric C.; Laher, Russ R.; Masci, Frank J.; Purdum, Josiah N.; Regnault, Nicolas "A Search for Relativistic Ejecta in a Sample of ZTF Broad-lined Type Ic Supernovae," *The Astrophysical Journal*, 953, 179, 2023.
- Cortes-Rangel, Geovanni; Zapata, Luis A.; Rivera-Ortiz, Pedro R.; Reiter, Megan; Takahashi, Satoko; Masqué, Josep M. "ALMA Observations of the Extraordinary Carina Pillars: A Complementary Sample," *The Astrophysical Journal*, 958, 193, 2023.
- Cowie, L. L.; Barger, A. J.; Bauer, F. E. "2 mm Observations and the Search for High-redshift Dusty Star-forming Galaxies," *The Astrophysical Journal*, 952, 28, 2023.
- Cox, P.; Neri, R.; Berta, S.; Ismail, D.; Stanley, F.; Young, A.; Jin, S.; Bakx, T.; Beelen, A.; Dannerbauer, H.; Krips, M.; Lehnert, M.; Omont, A.; Riechers, D. A.; Baker, A. J.; Bendo, G.; Borsato, E.; Buat, V.; Butler, K.; Chartab, N.; Cooray, A.; Dye, S.; Eales, S.; Gavazzi, R.; Hughes, D.; Ivison, R.; Jones, B. M.; Marchetti, L.; Messias, H.; Nanni, A.; Negrello, M.; Perez-Fournon, I.; Serjeant, S.; Urquhart, S.; Vlahakis, C.; Weiß, A.; Van Der Werf, P.; Yang, C. "z-GAL: A NOEMA spectroscopic redshift survey of bright Herschel galaxies. I. Overview," *Astronomy and Astrophysics*, 678, A26, 2023.
- Cramer, W. J.; Noble, A. G.; Massingill, K.; Cairns, J.; Clements, D. L.; Cooper, M. C.; Demarco, R.; Matharu, J.; McDonald, M.; Muzzin, A.; Nantais, J.; Rudnick, G.; Übler, H.; Van Kampen, E.; Webb, T. M. A.; Wilson, G.; Yee, H. K. C. "A Large-scale Kinematic Study of Molecular Gas in High-z Cluster Galaxies: Evidence for High Levels of Kinematic Asymmetry," *The Astrophysical Journal*, 944, 213, 2023.
- Crawford, Fronefield; Lazio, T. Joseph W.; McEwen, Alexander; Deneva, Julia S.; Cordes, James M.; Spitler, Laura; Trainor, Ryan F. "Measurements of the Crab Pulsar's Giant Radio Pulse Amplitude Power-law Index Using Low-frequency Arecibo and Green Bank Telescope Observations," *The Astrophysical Journal*, 948, 46, 2023.
- Crew, G. B.; Goddi, C.; Matthews, L. D.; Rottmann, H.; Saez, A.; Martí-Vidal, I. "A Characterization of the ALMA Phasing System at 345 GHz," *Publications of the Astronomical Society of the Pacific*, 135, 25002, 2023.
- Cronin-Coltsmann, Patrick F.; Kennedy, Grant M.; Kral, Quentin; Lestrade, Jean-François; Marino, Sebastian; Matrà, Luca; Wyatt, Mark C. "An ALMA Survey of M-dwarfs in the Beta Pictoris Moving Group with two new debris disc detections," *Monthly Notices of the Royal Astronomical Society*, 526, 5401, 2023.
- Cubillos, Diana; Espinoza, Camilo; Monasterio, David; Pizarro, José; Bronfman, Leonardo; Finger, Ricardo; Mena, F. Patricio "Design and Optimization of a Broadband Waveguide-to-50  $\Omega$ -Microstrip Transition for Q-Band Applications with Low-Loss and Easy Scalability," *Journal of Infrared, Millimeter, and Terahertz Waves*, 44, p.693-708, 2023.
- Cubuk, K. O.; Burton, M. G.; Braiding, C.; Wong, G. F.; Rowell, G.; Macted, N. I.; Eden, D.; Alsaberi, R. Z. E.; Blackwell, R.; Enokiya, R.; Feijen, K.; Filipović, M. D.; Freeman, M. S. R.; Fujita, S.; Ghavam, M.; Gunay, B.; Indermuehle, B.; Hayashi, K.; Kohno, M.; Nagaya, T.; Nishimura, A.; Okawa, K.; Rebolledo, D.; Romano, D.; Sano, H.; Snowswell, C.; Tohill, N. F. H.; Tsuge, K.; Voisin, F.; Yamane, Y.; Yoshiike, S. "The Mopra Southern Galactic Plane CO Survey - data release 4- complete survey," *Publications of the Astronomical Society of Australia*, 40, e047, 2023.
- Cui, Yuzhu; Hada, Kazuhiro; Kawashima, Tomohisa; Kino, Motoki; Lin, Weikang; Mizuno, Yosuke; Ro, Hyunwook; Honma, Mareki; Yi, Kunwoo; Yu, Jintao; Park, Jongho; Jiang, Wu; Shen, Zhiqiang; Kravchenko, Evgeniya; Algaba, Juan-Carlos; Cheng, Xiaopeng; Cho, Ilje; Giovannini, Gabriele; Giroletti, Marcello; Jung, Taehyun; Lu, Ru-Sen; Niinuma, Kotaro; Oh, Junghwan; Ohsuga, Ken; Sawada-Satoh, Satoko; Sohn, Bong Won; Takahashi, Hiroyuki R.; Takamura, Mieko; Tazaki, Fumie; Trippe, Sascha; Wajima, Kiyooki; Akiyama, Kazunori; An, Tao; Asada, Keiichi; Buttaccio, Salvatore; Byun, Do-Young; Cui, Lang; Hagiwara, Yoshiaki; Hirota, Tomoya; Hodgson, Jeffrey; Kawaguchi, Noriyuki; Kim, Jae-Young; Lee, Sang-Sung; Lee, Jee Won; Lee, Jeong Ae; Maccaferri, Giuseppe; Melis, Andrea; Melnikov, Alexey; Migoni, Carlo; Oh, Se-Jin; Sugiyama, Koichiro; Wang, Xuezheng; Zhang, Yingkang; Chen, Zhong; Hwang, Ju-Yeon; Jung, Dong-Kyu; Kim, Hyo-Ryoung; Kim, Jeong-Sook; Kobayashi, Hideyuki; Li, Bin; Li, Guanghui; Li, Xiaofei; Liu, Zhiyong; Liu, Qinghui; Liu, Xiang; Oh, Chung-Sik; Oyama, Tomoaki; Roh, Duk-Gyoo; Wang, Jinqing; Wang, Na; Wang, Shiqiang; Xia, Bo; Yan, Hao; Yeom, Jae-Hwan; Yonekura, Yoshinori; Yuan, Jianping; Zhang, Hua; Zhao, Rongbing; Zhong, Weiye "Precessing jet nozzle connecting to a spinning black hole in M87," *Nature*, 621, 711, 2023.

## APPENDIX A: PUBLICATIONS

- Cunningham, N.; Ginsburg, A.; Galván-Madrid, R.; Motte, F.; Csengeri, T.; Stutz, A. M.; Fernández-López, M.; Álvarez-Gutiérrez, R. H.; Armante, M.; Baug, T.; Bonfand, M.; Bontemps, S.; Braine, J.; Brouillet, N.; Busquet, G.; Díaz-González, D. J.; Di Francesco, J.; Gusdorf, A.; Herpin, F.; Liu, H.; López-Sepulcre, A.; Louvet, F.; Lu, X.; Maud, L.; Nony, T.; Olguin, F. A.; Pouteau, Y.; Rivera-Soto, R.; Sandoval-Garrido, N. A.; Sanhueza, P.; Tatematsu, K.; Townner, A. P. M.; Valeille-Manet, M. "ALMA-IMF. VII. First release of the full spectral line cubes: Core kinematics traced by DCN J = (3-2)," *Astronomy and Astrophysics*, 678, A194, 2023.
- Curone, P.; Testi, L.; Macías, E.; Tazzari, M.; Facchini, S.; Williams, J. P.; Clarke, C. J.; Natta, A.; Rosotti, G.; Toci, C.; Lodato, G. "Radio multiwavelength analysis of the compact disk CX Tau: Presence of strong free-free variability or anomalous microwave emission," *Astronomy and Astrophysics*, 677, A118, 2023.
- Curtin, Alice P.; Tendulkar, Shriharsh P.; Josephy, Alexander; Chawla, Pragya; Andersen, Bridget; Kaspi, Victoria M.; Bhardwaj, Mohit; Cassanelli, Tomas; Cook, Amanda; Dong, Fengqiu Adam; Fonseca, Emmanuel; Gaensler, B. M.; Kaczmarek, Jane F.; Lanman, Adam E.; Leung, Calvin; Pearlman, Aaron B.; Petroff, Emily; Pleunis, Ziggy; Rafiei-Ravandi, Masoud; Ransom, Scott M.; Shin, Kaitlyn; Scholz, Paul; Smith, Kendrick; Stairs, Ingrid "Limits on Fast Radio Burst-like Counterparts to Gamma-Ray Bursts Using CHIME/FRB," *The Astrophysical Journal*, 954, 154, 2023.
- Da Silva, Patrícia; Menezes, R. B.; Díaz, Y.; Rodríguez-Ardila, A.; López-Navas, E.; Arévalo, P.; Hernández-García, L. "A closer look at NGC 7314 nuclear region: a multiwavelength analysis of the Seyfert nucleus and its surroundings," *Monthly Notices of the Royal Astronomical Society*, 519, 1293, 2023.
- Dabhade, Pratik; Gopal-Krishna "The spectral index-flux density relation for extragalactic radio sources selected at metre and decametre wavelengths," *Astronomy and Astrophysics*, 675, L3, 2023.
- Dahal, Sumit; Brewer, Michael K.; Akins, Alex B.; Appel, John W.; Bennett, Charles L.; Bustos, Ricardo; Cleary, Joseph; Couto, Jullianna D.; Datta, Rahul; Eimer, Joseph; Essinger-Hileman, Thomas; Iuliano, Jeffrey; Li, Yunyang; Marriage, Tobias A.; Núñez, Carolina; Petroff, Matthew A.; Reeves, Rodrigo; Rostem, Karwan; Shi, Rui; Valle, Deniz A. N.; Watts, Duncan J.; Weiland, Janet L.; Wollack, Edward J.; Xu, Zhilei "Microwave Observations of Venus with CLASS," *The Planetary Science Journal*, 4, 154, 2023.
- Dale, Daniel A.; Boquien, Médéric; Barnes, Ashley T.; Belfiore, Francesco; Bigiel, Frank; Cao, Yixian; Chandar, Rupali; Chastenet, Jérémy; Chevance, Mélanie; Deger, Sinan; Egorov, Oleg V.; Grasha, Kathryn; Groves, Brent; Hassani, Hamid; Henny, Kiana F.; Klessen, Ralf S.; Kreckel, Kathryn; Kruijssen, J. M. Diederik; Larson, Kirsten L.; Lee, Janice C.; Leroy, Adam K.; Liu, Daizhong; Murphy, Eric J.; Rosolowsky, Erik; Sandstrom, Karin; Schinnerer, Eva; Sutter, Jessica; Thilker, David A.; Watkins, Elizabeth J.; Whitmore, Bradley C.; Williams, Thomas G. "PHANGS-JWST First Results: The Influence of Stellar Clusters on Polycyclic Aromatic Hydrocarbons in Nearby Galaxies," *The Astrophysical Journal*, 944, L23, 2023.
- Darling, Jeremy; Paine, Jennie; Reid, Mark J.; Menten, Karl M.; Sakai, Shoko; Ghez, Andrea "An Updated Reference Frame for the Galactic Inner Parsec," *The Astrophysical Journal*, 955, 117, 2023.
- Das, B.; Petit, V.; Nazé, Y.; Corcoran, M. F.; Cohen, D. H.; Biswas, A.; Chandra, P.; David-Uraz, A.; Leutenegger, M. A.; Neiner, C.; Pablo, H.; Paunzen, E.; Shultz, M. E.; Ud-Doula, A.; Wade, G. A. "Discovery of extraordinary X-ray emission from magnetospheric interaction in the unique binary stellar system Lupi," *Monthly Notices of the Royal Astronomical Society*, 522, 5805, 2023.
- Das, Barnali; Chandra, Poonam "Peculiar Spectral Property of Coherent Radio Emission from a Hot Magnetic Star: The Case of an Extreme Oblique Rotator," *The Astrophysical Journal*, 957, 53, 2023.
- Das, Sanskriti; Chiang, Yi-Kuan; Mathur, Smita "Detection of Thermal Sunyaev-Zel'dovich Effect in the Circumgalactic Medium of Low-mass Galaxies-A Surprising Pattern in Self-similarity and Baryon Sufficiency," *The Astrophysical Journal*, 951, 125, 2023.
- De Gasperin, F.; Edler, H. W.; Williams, W. L.; Callingham, J. R.; Asabere, B.; Brüggem, M.; Brunetti, G.; Dijkema, T. J.; Hardcastle, M. J.; Iacobelli, M.; Offringa, A.; Norden, M. J.; Röttgering, H. J. A.; Shimwell, T.; Van Weeren, R. J.; Tasse, C.; Bomans, D. J.; Bonafede, A.; Botteon, A.; Cassano, R.; Chyży, K. T.; Cuciti, V.; Emig, K. L.; Kadler, M.; Miley, G.; Mingo, B.; Oei, M. S. S. L.; Prandoni, I.; Schwarz, D. J.; Zarka, P. "The LOFAR LBA Sky Survey. II. First data release," *Astronomy and Astrophysics*, 673, A165, 2023.
- De Sarkar, Agnibha; Nayana, A. J.; Roy, Nirupam; Razzaque, Soebur; Anupama, G. C. "Lepto-hadronic Interpretation of 2021 RS Ophiuchi Nova Outburst," *The Astrophysical Journal*, 951, 62, 2023.
- De Wet, S.; Laskar, T.; Groot, P. J.; Cavallaro, F.; Nicuesa Guelbenzu, A.; Chastain, S.; Izzo, L.; Levan, A.; Malesani, D. B.; Monageng, I. M.; Van Der Horst, A. J.; Zheng, W.; Bloemen, S.; Filippenko, A. V.; Kann, D. A.; Klose, S.; Pieterse, D. L. A.; Rau, A.; Vreeswijk, P. M.; Woudt, P.; Zhu, Z.-P. "The triple-peaked afterglow of GRB 210731A from X-ray to radio frequencies," *Astronomy and Astrophysics*, 671, A116, 2023.
- De Witt, Aletha; Jacobs, Christopher S.; Gordon, David; Bietenholz, Michael; Nickola, Marisa; Bertarini, Alessandra "The Celestial Reference Frame at K Band: Imaging. I. The First 28 Epochs," *The Astronomical Journal*, 165, 139, 2023.
- De, Kishalay; Macleod, Morgan; Karambelkar, Viraj; Jencson, Jacob E.; Chakrabarty, Deepto; Conroy, Charlie; Dekany, Richard; Eilers, Anna-Christina; Graham, Matthew J.; Hillenbrand, Lynne A.; Kara, Erin; Kasliwal, Mansi M.; Kulkarni, S. R.; Lau, Ryan M.; Loeb, Abraham; Masci, Frank; Medford, Michael S.; Meisner, Aaron M.; Patel, Nimesh; Quiroga-Núñez, Luis Henry; Riddle, Reed L.; Rusholme, Ben; Simcoe, Robert; Sjouwerman, Loránt O.; Teague, Richard; Vanderburg, Andrew "An infrared transient from a star engulfing a planet," *Nature*, 617, 55, 2023.
- Decarli, Roberto; Pensabene, Antonio; Diaz-Santos, Tanio; Ferkinhoff, Carl; Strauss, Michael A.; Venemans, Bram P.; Walter, Fabian; Bañados, Eduardo; Bertoldi, Frank; Fan, Xiaohui; Farina, Emanuele Paolo; Riechers, Dominik A.; Rix, Hans-Walter; Wang, Ran "A comprehensive view of the interstellar medium in a quasar host galaxy at  $z \approx 6.4$ ," *Astronomy and Astrophysics*, 673, A157, 2023.
- Deconto-Machado, A.; Del Olmo Orozco, A.; Marziani, P.; Perea, J.; Stirpe, G. M. "High-redshift quasars along the main sequence," *Astronomy and Astrophysics*, 669, A83, 2023.
- Den Brok, J. S.; Leroy, A. K.; Usero, A.; Schinnerer, E.; Rosolowsky, E.; Koch, E. W.; Querejeta, M.; Liu, D.; Bigiel, F.; Barnes, A. T.; Chevance, M.; Colombo, D.; Dale, D. A.; Glover, S. C. O.; Jimenez-Donaire, M. J.; Teng, Y.-H.; Williams, T. G. "Resolved low-J12CO excitation at 190 parsec resolution across NGC 2903 and NGC 3627," *Monthly Notices of the Royal Astronomical Society*, 526, 6347, 2023.
- Den Brok, Jakob S.; Bigiel, Frank; Chastenet, Jérémy; Sandstrom, Karin; Leroy, Adam; Usero, Antonio; Schinnerer, Eva; Rosolowsky, Erik W.; Koch, Eric W.; Chiang, I-Da; Barnes, Ashley T.; Puschign, Johannes; Saito, Toshiki; Bešlić, Ivana; Chevance, Melanie; Dale, Daniel A.; Eibensteiner, Cosima; Glover, Simon; Jiménez-Donaire, María J.; Teng, Yu-Hsuan; Williams, Thomas G. "Wide-field CO isotopologue emission and the CO-to-H<sub>2</sub> factor across the nearby spiral galaxy M101," *Astronomy and Astrophysics*, 676, A93, 2023.
- Deng, Junhao; Jiang, Yunguo "Unravelling the secrets of blazar OT 081: a multiwavelength investigation," *Monthly Notices of the Royal Astronomical Society*, 521, 6210, 2023.
- Deng, Yunwei; Zhang, Zhi-Yu; Zhou, Ping; Wang, Junzhi; Fang, Min; Lin, Lingrui; Bian, Fuyan; Chen, Zhiwei; Shi, Yong; Chen, Guoyin; Li, Hui "Multiple gas phases in supernova remnant IC 443: mapping shocked H<sub>2</sub> with VLT/KMOS," *Monthly Notices of the Royal Astronomical Society*, 518, 2320, 2023.
- Dessauges-Zavadsky, Miroslava; Richard, Johan; Combes, Françoise; Messa, Matteo; Nagy, David; Mayer, Lucio; Schaerer, Daniel; Egami, Eiichi; Adamo, Angela "Molecular gas cloud properties at  $z \approx 1$  revealed by the superb angular resolution achieved with ALMA and gravitational

- lensing," *Monthly Notices of the Royal Astronomical Society*, 519, 6222, 2023.
- D'Eugenio, C.; Daddi, E.; Liu, D.; Gobat, R. "The [CII] 158  $\mu\text{m}$  emission line as a gas mass tracer in high redshift quiescent galaxies," *Astronomy and Astrophysics*, 678, L9, 2023.
- Dewangan, L. K.; Bhadari, N. K.; Maity, A. K.; Pandey, Rakesh; Sharma, Saurabh; Baug, T.; Eswaraiyah, C. "Star-forming site RAFGL 5085: Is a perfect candidate of hub-filament system?," *Journal of Astrophysics and Astronomy*, 44, 23, 2023.
- Dewangan, L. K.; Bhadari, N. K.; Men'Shchikov, A.; Chung, E. J.; Devaraj, R.; Lee, C. W.; Maity, A. K.; Baug, T. "IC 5146 Dark Streamer: The First Reliable Candidate of Edge Collapse, Hub-filament Systems, and Intertwined Sub-filaments," *The Astrophysical Journal*, 946, 22, 2023.
- Di Gennaro, G.; Brügggen, M.; Van Weeren, R. J.; Simionescu, A.; Brunetti, G.; Cassano, R.; Forman, W. R.; Hoeft, M.; Ignesti, A.; Röttgering, H. J. A.; Shimwell, T. W. "The diffuse radio emission in the high-redshift cluster PSZ2 G091.83+26.11: Total intensity and polarisation analysis with Very Large Array 1-4 GHz observations," *Astronomy and Astrophysics*, 675, A51, 2023.
- Di Gesu, Laura; Marshall, Herman L.; Ehlert, Steven R.; Kim, Dawoon E.; Donnarumma, Immacolata; Tavecchio, Fabrizio; Lioudakis, Ioannis; Kiehlmann, Sebastian; Agudo, Iván; Jorstad, Svetlana G.; Muleri, Fabio; Marscher, Alan P.; Puccetti, Simonetta; Middei, Riccardo; Perri, Matteo; Pacciani, Luigi; Negro, Michela; Romani, Roger W.; Di Marco, Alessandro; Blinov, Dmitry; Bourbahi, Ioakeim G.; Kontopodis, Evangelos; Mandarakas, Nikos; Romanopoulos, Stylianos; Skalidis, Raphael; Vervelaki, Anna; Casadio, Carolina; Escudero, Juan; Myserlis, Ioannis; Gurwell, Mark A.; Rao, Ramprasad; Keating, Garrett K.; Kouch, Pouya M.; Lindfors, Elina; Aceituno, Francisco José; Bernardos, Maria I.; Bonnoli, Giacomo; Casanova, Víctor; García-Comas, Maya; Agís-González, Beatriz; Husillos, César; Marchini, Alessandro; Sota, Alfredo; Imazawa, Ryo; Sasada, Mahito; Fukazawa, Yasushi; Kawabata, Koji S.; Uemura, Makoto; Mizuno, Tsunefumi; Nakaoka, Tatsuya; Akitaya, Hiroshi; Savchenko, Sergey S.; Vasilyev, Andrey A.; Gómez, José L.; Antonelli, Lucio A.; Barnouin, Thibault; Bonino, Raffaella; Cavazzuti, Elisabetta; Costamante, Luigi; Chen, Chien-Ting; Cibbario, Nicolò; De Rosa, Alessandra; Di Pierro, Federico; Errando, Manel; Kaaret, Philip; Karas, Vladimir; Krawczynski, Henric; Lisalda, Lindsey; Madejski, Grzegorz; Malacaria, Christian; Marín, Frédéric; Marinucci, Andrea; Massaro, Francesco; Matt, Giorgio; Mitsuishi, Ikuyuki; O'Dell, Stephen L.; Paggi, Alessandro; Peirson, Abel L.; Petrucci, Pierre-Olivier; Ramsey, Brian D.; Tennant, Allyn F.; Wu, Kinwah; Bachetti, Matteo; Baldini, Luca; Baumgartner, Wayne H.; Bellazzini, Ronaldo; Bianchi, Stefano; Bongiorno, Stephen D.; Brez, Alessandro; Bucciantini, Niccolò; Capitanio, Fiamma; Castellano, Simone; Ciprini, Stefano; Costa, Enrico; Del Monte, Ettore; Di Lalla, Niccolò; Doroshenko, Victor; Dovčiak, Michal; Enoto, Teruaki; Evangelista, Yuri; Fabiani, Sergio; Ferrazzoli, Riccardo; Garcia, Javier A.; Gunji, Shuichi; Hayashida, Kiyoshi; Heyl, Jeremy; Iwakiri, Wataru; Kislak, Fabian; Kitaguchi, Takao; Kolodziejczak, Jeffery J.; La Monaca, Fabio; Latronico, Luca; Maldera, Simone; Manfreda, Alberto; Ng, C.-Y.; Omodei, Nicola; Oppedisano, Chiara; Papitto, Alessandro; Pavlov, George G.; Pesce-Rollins, Melissa; Pilia, Maura; Possenti, Andrea; Poutanen, Juri; Rankin, John; Ratheesh, Ajay; Roberts, Oliver J.; Sgró, Carmelo; Slane, Patrick; Soffitta, Paolo; Spandre, Gloria; Swartz, Douglas A.; Tamagawa, Toru; Taverna, Roberto; Tawara, Yuzuru; Thomas, Nicholas E.; Tombesi, Francesco; Trois, Alessio; Tsygankov, Sergey S.; Turolla, Roberto; Vink, Jacco; Weisskopf, Martin C.; Xie, Fei; Zane, Silvia "Discovery of X-ray polarization angle rotation in the jet from blazar Mrk 421," *Nature Astronomy*, 7, 1245, 2023.
- Di Marco, Valentina; Zic, Andrew; Miles, Matthew T.; Reardon, Daniel J.; Thrane, Eric; Shannon, Ryan M. "Toward Robust Detections of Nanohertz Gravitational Waves," *The Astrophysical Journal*, 956, 14, 2023.
- Di Mascolo, Luca; Saro, Alessandro; Mroczkowski, Tony; Borgani, Stefano; Churazov, Eugene; Rasia, Elena; Tozzi, Paolo; Dannerbauer, Helmut; Basu, Kaustuv; Carilli, Christopher L.; Ginolfi, Michele; Miley, George; Nonino, Mario; Pannella, Maurilio; Pentericci, Laura; Rizzo, Francesca "Forming intracluster gas in a galaxy protocluster at a redshift of 2.16," *Nature*, 615, 809, 2023.
- Di Teodoro, Enrico M.; Posti, Lorenzo; Fall, S. Michael; Ogle, Patrick M.; Jarrett, Thomas; Appleton, Philip N.; Cluver, Michelle E.; Haynes, Martha P.; Lisenfeld, Ute "Dark matter halos and scaling relations of extremely massive spiral galaxies from extended H I rotation curves," *Monthly Notices of the Royal Astronomical Society*, 518, 6340, 2023.
- Díaz-González, Daniel J.; Galván-Madrid, Roberto; Ginsburg, Adam; Motte, Frédéric; Dell'Ova, Pierre; Kurtz, Stanley; Cunningham, Nichol; Stutz, Amelia M.; Louvet, Fabien; Csengeri, Tímea; Fernández-López, Manuel; Sanhueza, Patricio; Nony, Thomas; Rivera-Soto, Rudy; Álvarez-Gutiérrez, Rodrigo H.; Armante, Melanie; Bonfand, Melisse; Bontemps, Sylvain; Gusdorf, Antoine; Liu, Hong-Li "ALMA-IMF. VIII. Combination of Interferometric Continuum Images with Single-dish Surveys and Structural Analysis of Six Protoclusters," *The Astrophysical Journal Supplement Series*, 269, 55, 2023.
- Dib, Sami "The evolution of the internal structure of massive star forming regions in the Milky Way as revealed by ALMA," *Monthly Notices of the Royal Astronomical Society*, 524, 1625, 2023.
- Dickey, John M.; Vrtilik, S. D.; Mccollough, Michael; Boroson, Bram; Tomsick, John A.; Bailyn, Charles; Blanchard, Jay M.; Johnson, Charlotte "Spectral Energy Distributions of Southern Binary X-Ray Sources," *The Astrophysical Journal Supplement Series*, 268, 35, 2023.
- Ding, H.; Deller, A. T.; Stappers, B. W.; Lazio, T. J. W.; Kaplan, D.; Chatterjee, S.; Brisken, W.; Cordes, J.; Freire, P. C. C.; Fonseca, E.; Stairs, I.; Guillemot, L.; Lyne, A.; Cognard, I.; Reardon, D. J.; Theureau, G. "The MSPSRM catalogue: VLBA astrometry of 18 millisecond pulsars," *Monthly Notices of the Royal Astronomical Society*, 519, 4982-5007, 2023.
- D'Odorico, Valentina; Bañados, E.; Becker, G. D.; Bischetti, M.; Bosman, S. E. I.; Cupani, G.; Davies, R.; Farina, E. P.; Ferrara, A.; Feruglio, C.; Mazzucchelli, C.; Ryan-Weber, E.; Schindler, J.-T.; Sodin, A.; Venemans, B. P.; Walter, F.; Chen, H.; Lai, S.; Zhu, Y.; Bian, F.; Campo, S.; Carniani, S.; Cristiani, S.; Davies, F.; Decarli, R.; Drake, A.; Eilers, A.-C.; Fan, X.; Gaikwad, P.; Gallerani, S.; Greig, B.; Haehnelt, M. G.; Hennawi, J.; Keating, L.; Kulkarni, G.; Mesinger, A.; Meyer, R. A.; Neeleman, M.; Onoue, M.; Pallottini, A.; Qin, Y.; Rojas-Ruiz, S.; Satyavolu, S.; Sebastian, A.; Tripodi, R.; Wang, F.; Wolfson, M.; Yang, J.; Zanchetti, M. V. "XQR-30: The ultimate XSHOOTER quasar sample at the reionization epoch," *Monthly Notices of the Royal Astronomical Society*, 523, 1399, 2023.
- Doi, Kiyooki; Kataoka, Akimasa "Constraints on the Dust Size Distributions in the HD 163296 Disk from the Difference of the Apparent Dust Ring Widths between Two ALMA Bands," *The Astrophysical Journal*, 957, 11, 2023.
- Dokara, R.; Gong, Y.; Reich, W.; Rugel, M. R.; Brunthaler, A.; Menten, K. M.; Cotton, W. D.; Dzib, S. A.; Khan, S.; Medina, S. -N. X.; Nguyen, H.; Ortiz-León, G. N.; Urquhart, J. S.; Wyrowski, F.; Yang, A. Y.; Anderson, L. D.; Beuther, H.; Csengeri, T.; Müller, P.; Ott, J.; Pandian, J. D.; Roy, N. "A global view on star formation: The GLOSTAR Galactic plane survey. VII. Supernova remnants in the Galactic longitude range  $28^\circ < l < 36^\circ$ ," *Astronomy and Astrophysics*, 671, A145, 2023.
- Dokara, Rohit; Roy, Nirupam; Menten, Karl; Vig, Sarita; Dutta, Prasun; Beuther, Henrik; Pandian, Jagadheep D.; Rugel, Michael; Rashid, Md; Brunthaler, Andreas "Metrowave Galactic Plane with the uGMRT (MeGaPluG) Survey: Lessons from the pilot study," *Astronomy and Astrophysics*, 678, A72, 2023.
- Dong, Dillon Z.; Hallinan, Gregg "A Flat-spectrum Radio Transient at 122 Mpc Consistent with an Emerging Pulsar Wind Nebula," *The Astrophysical Journal*, 948, 119, 2023.
- Downes, Turlough P.; Hartigan, Patrick; Isella, Andrea "Length-scales and dynamics of Carina's Western wall," *Monthly Notices of the Royal Astronomical Society*, 519, 5427, 2023.
- Drevet Mulard, M.; Nesvadba, N. P. H.; Meenakshi, M.; Mukherjee, D.;

## APPENDIX A: PUBLICATIONS

- Wagner, A.; Bicknell, G.; Neumayer, N.; Combes, F.; Zovaro, H.; Janssen, R. M. J.; Bagchi, J.; Dabhade, P.; Prunet, S. "Star formation in a massive spiral galaxy with a radio-AGN," *Astronomy and Astrophysics*, 676, A35, 2023.
- Driessen, Laura N.; Heald, George; Duchesne, Stefan W.; Murphy, Tara; Lenc, Emil; Leung, James K.; Moss, Vanessa A. "Detection of radio emission from stars via proper-motion searches," *Publications of the Astronomical Society of Australia*, 40, e036, 2023.
- Drozhdovskaya, Maria N.; Bockelée-Morvan, Dominique; Crovisier, Jacques; Mcguire, Brett A.; Biver, Nicolas; Charnley, Steven B.; Cordiner, Martin A.; Milam, Stefanie N.; Opitom, Cyrielle; Remijan, Anthony J. "Low NH<sub>3</sub>/H<sub>2</sub>O ratio in comet C/2020 F3 (NEOWISE) at 0.7 au from the Sun," *Astronomy and Astrophysics*, 677, A157, 2023.
- Du, Kaiyi; Shi, Yong; Zhang, Zhi-Yu; Gu, Qiusheng; Wang, Tao; Wang, Junzhi; Li, Xin; Zhai, Sai "The volumetric extended-Schmidt law: a unity slope," *Monthly Notices of the Royal Astronomical Society*, 518, 4024, 2023.
- Duan, Hao-Yuan; Lai, Shih-Ping; Hirano, Naomi; Thieme, Travis J. "Modeling Two First Hydrostatic Core Candidates Barnard 1b-N and 1b-S," *The Astrophysical Journal*, 947, 48, 2023.
- Duan, Yan; Li, Di; Pagani, Laurent; Goldsmith, Paul F.; Ching, Tao-Chung; Wang, Chen; Xie, Jinjin "Updated Inventory of Carbon Monoxide in the Taurus Molecular Cloud," *Research in Astronomy and Astrophysics*, 23, 95006, 2023.
- Duncan, Kenneth J.; Windhorst, Rogier A.; Koekemoer, Anton M.; Röttgering, Huub J. A.; Cohen, Seth H.; Jansen, Rolf A.; Summers, Jake; Tompkins, Scott; Hutchison, Taylor A.; Conselice, Christopher J.; Driver, Simon P.; Yan, Haojing; Adams, Nathan J.; Cheng, Cheng; Coe, Dan; Diego, Jose M.; Dole, Hervé; Frye, Brenda; Gim, Hansung B.; Grogan, Norman A.; Holwerda, Benne W.; Lim, Jeremy; Marshall, Madeline A.; Nonino, Mario; Pirzkal, Nor; Robotham, Aaron; Ryan, Russell E.; Willmer, Christopher N. A. "JWST's PEARLS: TN J1338-1942 - I. Extreme jet-triggered star formation in a z = 4.11 luminous radio galaxy," *Monthly Notices of the Royal Astronomical Society*, 522, 4548, 2023.
- Duncan, Ruby A.; Van Der Horst, Alexander J.; Beniamini, Paz "Constraints on electron acceleration in gamma-ray bursts afterglows from radio peaks," *Monthly Notices of the Royal Astronomical Society*, 518, 1522, 2023.
- Durré, Mark; Mould, Jeremy; Brown, Michael; Reynolds, Tristan "Infrared spectroscopy of nearby radio active early-type galaxies - II: spectral atlas," *Monthly Notices of the Royal Astronomical Society*, 524, 4923, 2023.
- Dutta, Sushant; Singh, Veeresh; Chandra, C. H. Ishwara; Wadadekar, Yogesh; Kayal, Abhijit; Heywood, Ian "Search and Characterization of Remnant Radio Galaxies in the XMM-LSS Deep Field," *The Astrophysical Journal*, 944, 176, 2023.
- Duvidovich, L.; Petriella, A. "Radio and infrared study of the supernova remnant candidate HESS J1912+101," *Astronomy and Astrophysics*, 672, A195, 2023.
- Dux, Frédéric; Lemon, Cameron; Courbin, Frédéric; Sluse, Dominique; Smette, Alain; Anguita, Timo; Neira, Favio "PS J2107-1611: A new wide-separation, quadruply imaged lensed quasar with flux ratio anomalies," *Astronomy and Astrophysics*, 679, L4, 2023.
- Dzib, S. A.; Yang, A. Y.; Urquhart, J. S.; Medina, S. -N. X.; Brunthaler, A.; Menten, K. M.; Wyrowski, F.; Cotton, W. D.; Dokara, R.; Ortiz-León, G. N.; Rugel, M. R.; Nguyen, H.; Gong, Y.; Chakraborty, A.; Beuther, H.; Billington, S. J.; Carrasco-Gonzalez, C.; Csengeri, T.; Hofner, P.; Ott, J.; Pandian, J. D.; Roy, N.; Yanza, V. "A global view on star formation: The GLOSTAR Galactic plane survey. VI. Radio Source Catalog II: 28° <  $\ell$  < 36° and  $|\text{b}| < 1^\circ$ , VLA B-configuration," *Astronomy and Astrophysics*, 670, A9, 2023.
- Eddins, Avery; Lee, Kyung-Hwan; Corsi, Alessandra; Bartos, Imre; Márka, Zsuzsanna; Márka, Szabolcs "A Search for Kilonova Radio Flares in a Sample of Swift/BAT Short Gamma-Ray Bursts," *The Astrophysical Journal*, 948, 125, 2023.
- Edris, Khaled A.; Darwish, Mohamed S. "Dust emissions and OH masers: evidence for tracing advanced stages of HMPOs," *European Physical Journal Plus*, 138, 717, 2023.
- Eftekhari, T.; Fong, W.; Gordon, A. C.; Sridhar, N.; Kilpatrick, C. D.; Bhandari, S.; Deller, A. T.; Dong, Y.; Rouco Escorial, A.; Heintz, K. E.; Leja, J.; Margalit, B.; Metzger, B. D.; Pearlman, A. B.; Prochaska, J. X.; Ryder, S. D.; Scholz, P.; Shannon, R. M.; Tejos, N. "An X-Ray Census of Fast Radio Burst Host Galaxies: Constraints on Active Galactic Nuclei and X-Ray Counterparts," *The Astrophysical Journal*, 958, 66, 2023.
- Egorov, Oleg V.; Kreckel, Kathryn; Sandstrom, Karin M.; Leroy, Adam K.; Glover, Simon C. O.; Groves, Brent; Kruijssen, J. M. Diederik; Barnes, Ashley. T.; Belfiore, Francesco; Bigiel, F.; Blanc, Guillermo A.; Boquien, Médiac; Cao, Yixian; Chastenot, Jérémy; Chevance, Mélanie; Congiu, Enrico; Dale, Daniel A.; Emsellem, Eric; Grasha, Kathryn; Klessen, Ralf S.; Larson, Kirsten L.; Liu, Daizhong; Murphy, Eric J.; Pan, Hsi-An; Pessa, Ismael; Pety, Jérôme; Rosolowsky, Erik; Scheuermann, Fabian; Schinnerer, Eva; Sutter, Jessica; Thilker, David A.; Watkins, Elizabeth J.; Williams, Thomas G. "PHANGS-JWST First Results: Destruction of the PAH Molecules in H II Regions Probed by JWST and MUSE," *The Astrophysical Journal*, 944, L16, 2023.
- Eibensteiner, C.; Bigiel, F.; Leroy, A. K.; Koch, E. W.; Rosolowsky, E.; Schinnerer, E.; Sardone, A.; Meidt, S.; De Blok, W. J. G.; Thilker, D.; Pisano, D. J.; Ott, J.; Barnes, A.; Querejeta, M.; Emsellem, E.; Puschignig, J.; Utomo, D.; Bešlić, I.; Den Brok, J.; Faridani, S.; Glover, S. C. O.; Grasha, K.; Hassani, H.; Henshaw, J. D.; Jiménez-Donaire, M. J.; Kerp, J.; Dale, D. A.; Kruijssen, J. M. D.; Laudage, S.; Sanchez-Blazquez, P.; Smith, R.; Stuber, S.; Pessa, I.; Watkins, E. J.; Williams, T. G.; Winkel, B. "Kinematic analysis of the super-extended H I disk of the nearby spiral galaxy M 83," *Astronomy and Astrophysics*, 675, A37, 2023.
- Einig, Lucas; Pety, Jérôme; Roueff, Antoine; Vandame, Paul; Chanussot, Jocelyn; Gerin, Maryvonne; Orkisz, Jan H.; Palud, Pierre; Santa-Maria, Miriam G.; De Souza Magalhaes, Victor; Bešlić, Ivana; Bardeau, Sébastien; Bron, Emeric; Chainais, Pierre; Goicoechea, Javier R.; Gratier, Pierre; Guzmán, Viviana V.; Hughes, Annie; Kainulainen, Jouni; Languignon, David; Lallement, Rosine; Levrier, François; Lis, Dariusz C.; Liszt, Harvey S.; Le Bourlot, Jacques; Le Petit, Franck; Öberg, Karin; Peretto, Nicolas; Roueff, Evelyne; Sievers, Albrecht; Thouvenin, Pierre-Antoine; Tremblin, Pascal "Deep learning denoising by dimension reduction: Application to the ORION-B line cubes," *Astronomy and Astrophysics*, 677, A158, 2023.
- Emig, Kimberly L.; Gupta, Neeraj; Salas, Pedro; Muller, Sébastien; Balashev, Sergei A.; Combes, Françoise; Momjian, Emmanuel; Song, Yiqing; Jagannathan, Preshanth; Deka, Partha P.; Józsa, Gyula I. G.; Klöckner, Hans-Rainer; Mohapatra, Abhisek; Noterdaeme, Pasquier; Petitjean, Patrick; Srikanand, Raghunathan; Wagenfeld, Jonah D. "Discovery of Hydrogen Radio Recombination Lines at z = 0.89 toward PKS 1830-211," *The Astrophysical Journal*, 944, 93, 2023.
- Emonts, Bjorn H. C.; Lehnert, Matthew D.; Lebowitz, Sophie; Miley, George K.; Villar-Martín, Montserrat; Norris, Ray; De Breuck, Carlos; Carilli, Chris; Feain, Ilana "CO Survey of High-z Radio Galaxies, Revisited with the Atacama Large Millimeter/submillimeter Array: Jet-Cloud Alignments and Synchrotron Brightening by Molecular Gas in the Circumgalactic Environment," *The Astrophysical Journal*, 952, 148, 2023.
- Emonts, Bjorn H. C.; Lehnert, Matthew D.; Yoon, Ilsang; Mandelker, Nir; Villar-Martín, Montserrat; Miley, George K.; De Breuck, Carlos; Pérez-Torres, Miguel A.; Hatch, Nina A.; Guillard, Pierre "A cosmic stream of atomic carbon gas connected to a massive radio galaxy at redshift 3.8," *Science*, 379, 1323, 2023.
- Endsley, Ryan; Stark, Daniel P.; Lyu, Jianwei; Wang, Feige; Yang, Jinyi; Fan, Xiaohui; Smit, Renske; Bouwens, Rychard; Hainline, Kevin; Schouws, Sander "ALMA confirmation of an obscured hyperluminous radio-loud AGN at z = 6.853 associated with a dusty starburst in the 1.5 deg<sup>2</sup> COSMOS field," *Monthly Notices of the Royal Astronomical Society*, 520, 4609, 2023.
- Enokiya, Rei; Sano, Hidetoshi; Filipović, Miroslav D.; Alsaberi, Rami Z. E.; Inoue, Tsuyoshi; Oka, Tomoharu "Discovery of a molecular cloud

- possibly associated with the youngest Galactic SNR G1.9+0.3," *Publications of the Astronomical Society of Japan*, 75, 970, 2023.
- Evans, L.; Vastel, C.; Fontani, F.; Pineda, J. E.; Jiménez-Serra, I.; Alves, F.; Sakai, T.; Bouvier, M.; Caselli, P.; Ceccarelli, C.; Chandler, C.; Svoboda, B.; Maud, L.; Codella, C.; Sakai, N.; Le Gal, R.; López-Sepulcre, A.; Moellenbrock, G.; Yamamoto, S. "FAUST. X. Formaldehyde in the protobinary system [BHB2007] 1f: Small-scale deuteration," *Astronomy and Astrophysics*, 678, A160, 2023.
- Evans, Neal J.; Li, Yang, Yao-Lun; Green, Joel D.; Zhao, Bo; Di Francesco, James; Lee, Jeong-Eun; Jørgensen, Jes K.; Choi, Minho; Myers, Philip C.; Mardones, Diego "Models of Rotating Infall for the B335 Protostar," *The Astrophysical Journal*, 943, 90, 2023.
- Event Horizon Telescope Collaboration; Akiyama, Kazunori; Alberdi, Anton; Alef, Walter; Algaba, Juan Carlos; Anantua, Richard; Asada, Keiichi; Azulay, Rebecca; Bach, Uwe; Baczko, Anne-Kathrin; Ball, David; Baloković, Mislav; Barrett, John; Bauböck, Michi; Benson, Bradford A.; Bintley, Dan; Blackburn, Lindy; Blundell, Raymond; Bouman, Katherine L.; Bower, Geoffrey C.; Boyce, Hope; Bremer, Michael; Brinkerink, Christiaan D.; Brissenden, Roger; Britzen, Silke; Broderick, Avery E.; Brogiere, Dominique; Bronzwaer, Thomas; Bustamante, Sandra; Byun, Do-Young; Karlstrom, John E.; Ceccobello, Chiara; Chael, Andrew; Chan, Chi-Kwan; Chang, Dominic O.; Chatterjee, Koushik; Chatterjee, Shami; Chen, Ming-Tang; Chen, Yongjun; Cheng, Xiaopeng; Cho, Ilje; Christian, Pierre; Conroy, Nicholas S.; Conway, John E.; Cordes, James M.; Crawford, Thomas M.; Crew, Geoffrey B.; Cruz-Osorio, Alejandro; Cui, Yuzhu; Dahale, Rohan; Davelaar, Jordy; De Laurentis, Mariafelicia; Deane, Roger; Dempsey, Jessica; Desvignes, Gregory; Dexter, Jason; Dhruv, Vedant; Doeleman, Sheperd S.; Dougal, Sean; Dzib, Sergio A.; Eatough, Ralph P.; Emami, Razieh; Falcke, Heino; Farah, Joseph; Fish, Vincent L.; Fomalont, Ed; Ford, H. Alyson; Foschi, Marianna; Fraga-Encinas, Raquel; Freeman, William T.; Friberg, Per; Fromm, Christian M.; Fuentes, Antonio; Galison, Peter; Gammie, Charles F.; García, Roberto; Gentaz, Olivier; Georgiev, Boris; Goddi, Ciriaco; Gold, Roman; Gómez-Ruiz, Arturo I.; Gómez, José L.; Gu, Minfeng; Gurwell, Mark; Hada, Kazuhiro; Haggard, Daryl; Haworth, Kari; Hecht, Michael H.; Hesper, Ronald; Heumann, Dirk; Ho, Luis C.; Ho, Paul; Honma, Mareki; Huang, Chih-Wei L.; Huang, Lei; Hughes, David H.; Ikeda, Shiro; Impellizzeri, C. M. Violette; Inoue, Makoto; Issaoun, Sara; James, David J.; Jannuzi, Buell T.; Janssen, Michael; Jeter, Britton; Jiang, Wu; Jiménez-Rosales, Alejandra; Johnson, Michael D.; Jorstad, Svetlana; Joshi, Abhishek V.; Jung, Taehyun; Karami, Mansour; Karuppusamy, Ramesh; Kawashima, Tomohisa; Keating, Garrett K.; Kettner, Mark; Kim, Dong-Jin; Kim, Jae-Young; Kim, Jongsoo; Kim, Junhan; Kino, Motoki; Koay, Jun Yi; Koehlerakota, Prashant; Kofuji, Yutaro; Koch, Patrick M.; Koyama, Shoko; Kramer, Carsten; Kramer, Joana A.; Kramer, Michael; Krichbaum, Thomas P.; Kuo, Cheng-Yu; La Bella, Noemi; Lauer, Tod R.; Lee, Daeyoung; Lee, Sang-Sung; Leung, Po Kin; Levis, Aviad; Li, Zhiyuan; Lico, Rocco; Lindahl, Greg; Lindqvist, Michael; Lisakov, Mikhail; Liu, Jun; Liu, Kuo; Liuzzo, Elisabetta; Lo, Wen-Ping; Lobanov, Andrei P.; Loinard, Laurent; Lonsdale, Colin J.; Lowitz, Amy E.; Lu, Ru-Sen; Macdonald, Nicholas R.; Mao, Jirong; Marchili, Nicola; Markoff, Sera; Marrone, Daniel P.; Marscher, Alan P.; Martí-Vidal, Iván; Matsushita, Satoki; Matthews, Lynn D.; Medeiros, Lia; Menten, Karl M.; Michalik, Daniel; Mizuno, Izumi; Mizuno, Yosuke; Moran, James M.; Moriyama, Kotaro; Moscibrodzka, Monika; Mulaudzi, Wang; Müller, Cornelia; Müller, Hendrik; Mus, Alejandro; Musoke, Gibwa; Myserlis, Ioannis; Nadolski, Andrew; Nagai, Hiroshi; Nagar, Neil M.; Nakamura, Masanori; Narayan, Ramesh; Narayanan, Gopal; Natarajan, Iniyani; Nathanail, Antonios; Fuentes, Santiago Navarro; Neilsen, Joey; Neri, Roberto; Ni, Chunhong; Noutsos, Aristeidis; Nowak, Michael A.; Oh, Junghwan; Okino, Hiroki; Olivares, Héctor; Ortiz-León, Gisela N.; Oyama, Tomoaki; Özel, Feryal; Palumbo, Daniel C. M.; Paraschos, Georgios Filippou; Park, Jongho; Parsons, Harriet; Patel, Nimesh; Pen, Ue-Li; Pesce, Dominic W.; Piétu, Vincent; Plambeck, Richard; Popstefanija, Aleksandar; Porth, Oliver; Pötzl, Felix M.; Prather, Ben; Preciado-López, Jorge A.; Psaltis, Dimitrios; Pu, Hung-Yi; Ramakrishnan, Venkatesh; Rao, Ramprasad; Rawlings, Mark G.; Raymond, Alexander W.; Rezzolla, Luciano; Ricarte, Angelo; Ripperda, Bart; Roelofs, Freek; Rogers, Alan; Romero-Cañizales, Cristina; Ros, Eduardo; Roshanineshat, Arash; Rottmann, Helge; Roy, Alan L.; Ruiz, Ignacio; Ruszczyk, Chet; Rygl, Kazi L. J.; Sánchez, Salvador; Sánchez-Argüelles, David; Sánchez-Portal, Miguel; Sasada, Mahito; Satapathy, Kaushik; Savolainen, Tuomas; Schloerb, F. Peter; Schonfeld, Jonathan; Schuster, Karl-Friedrich; Shao, Lijing; Shen, Zhiqiang; Small, Des; Sohn, Bong Won; Soohoo, Jason; Sosapanta Salas, León David; Souccar, Kamal; Sun, He; Tazaki, Fumie; Tetarenko, Alexandra J.; Tiede, Paul; Tilanus, Remo P. J.; Titus, Michael; Torne, Pablo; Toscano, Teresa; Traianou, Efthalia; Trent, Tyler; Trippe, Sascha; Turk, Matthew; Van Bemmell, Ilse; Van Langevelde, Huib Jan; Van Rossum, Daniel R.; Vos, Jesse; Wagner, Jan; Ward-Thompson, Derek; Wardle, John; Washington, Jasmin E.; Weintraub, Jonathan; Wharton, Robert; Wielgus, Maciek; Wiik, Kaj; Witzel, Gunther; Wondrak, Michael F.; Wong, George N.; Wu, Qingwen; Yadlapalli, Nitika; Yamaguchi, Paul; Yfantis, Aristomenis; Yoon, Doosoo; Young, André; Young, Ken; Younsi, Ziri; Yu, Wei; Yuan, Feng; Yuan, Ye-Fei; Zensus, J. Anton; Zhang, Shuo; Zhao, Guang-Yao; Zhao, Shan-Shan "First M87 Event Horizon Telescope Results. IX. Detection of Near-horizon Circular Polarization," *The Astrophysical Journal*, 957, L20, 2023.
- Eyles-Ferris, R. A. J.; Starling, R. L. C. "Finding LoTSS of hosts for GRBs: a search for galaxy - gamma-ray burst coincidences at low frequencies with LOFAR," *Monthly Notices of the Royal Astronomical Society*, 524, 3958, 2023.
- Fadda, Dario; Colditz, Sebastian; Fischer, Christian; Vacca, William D.; Chu, Jason; Clarke, Melanie; Klein, Randolph; Krabbe, Alfred; Minchin, Robert; Poglitsch, Albrecht "Characterization and Absolute Calibration of the Far-infrared Field Integral Line Spectrometer for SOFIA," *The Astronomical Journal*, 166, 237, 2023.
- Fadda, Dario; Sutter, Jessica S.; Minchin, Robert; Polles, Fiorella "Shock Enhanced [C II] Emission from the Infalling Galaxy Arp 25," *The Astrophysical Journal*, 957, 83, 2023.
- Fallon, Paul; Smits, Derck P.; Ghosh, Tapasi; Salter, Christopher J.; Salas, Pedro "Point Source C-band Mueller Matrices for the Green Bank Telescope," *The Astronomical Journal*, 166, 26, 2023.
- Falxa, M.; Babak, S.; Baker, P. T.; Bécsy, B.; Chalumeau, A.; Chen, S.; Chen, Z.; Cornish, N. J.; Guillemot, L.; Hazboun, J. S.; Mingarelli, C. M. F.; Parthasarathy, A.; Petiteau, A.; Pol, N. S.; Sesana, A.; Spolaor, S. B.; Taylor, S. R.; Theureau, G.; Vallisneri, M.; Vigeland, S. J.; Witt, C. A.; Zhu, X.; Antoniadis, J.; Arzoumanian, Z.; Bailes, M.; Bhat, N. D. R.; Blecha, L.; Brazier, A.; Brook, P. R.; Caballero, N.; Cameron, A. D.; Casey-Clyde, J. A.; Champion, D.; Charisi, M.; Chatterjee, S.; Cognard, I.; Cordes, J. M.; Crawford, F.; Cromartie, H. T.; Crowter, K.; Dai, S.; Decesar, M. E.; Demorest, P. B.; Desvignes, G.; Dolch, T.; Drachler, B.; Feng, Y.; Ferrara, E. C.; Fiore, W.; Fonseca, E.; Garver-Daniels, N.; Glaser, J.; Goncharov, B.; Good, D. C.; Griessmeier, J.; Guo, Y. J.; Gültekin, K.; Hobbs, G.; Hu, H.; Islo, K.; Jang, J.; Jennings, R. J.; Johnson, A. D.; Jones, M. L.; Kaczmarek, J.; Kaiser, A. R.; Kaplan, D. L.; Keith, M.; Kelley, L. Z.; Kerr, M.; Key, J. S.; Laal, N.; Lam, M. T.; Lamb, W. G.; Lazio, T. J. W.; Liu, K.; Liu, T.; Luo, J.; Lynch, R. S.; Madison, D. R.; Main, R.; Manchester, R.; McEwen, A.; Mckee, J.; Mclaughlin, M. A.; Ng, C.; Nice, D. J.; Ocker, S.; Olum, K. D.; Osłowski, S.; Pennucci, T. T.; Perera, B. B. P.; Perrodin, D.; Porayko, N.; Possenti, A.; Quelquejey-Leclere, H.; Ransom, S. M.; Ray, P. S.; Reardon, D. J.; Russell, C. J.; Samajdar, A.; Sarkissian, J.; Schult, L.; Shaifullah, G.; Shannon, R. M.; Shapiro-Albert, B. J.; Siemens, X.; Simon, J. J.; Siwek, M.; Smith, T. L.; Speri, L.; Spiewak, R.; Stairs, I. H.; Stappers, B.; Stinebring, D. R.; Swiggum, J. K.; Tiburzi, C.; Turner, J.; Vecchio, A.; Verbiest, J. P. W.; Wahl, H.; Wang, S. Q.; Wang, J.; Wu, Z.; Zhang, L.; Zhang, S. "Searching for continuous Gravitational Waves in the second data release of the International Pulsar Timing Array," *Monthly Notices of the Royal Astronomical Society*, 521, 5077, 2023.
- Fang, Ke; Lopez Rodriguez, Enrique; Halzen, Francis; Gallagher, John S. "High-energy Neutrinos from the Inner Circumnuclear Region of NGC

## APPENDIX A: PUBLICATIONS

- 1068," *The Astrophysical Journal*, 956, 8, 2023.
- Farrah, Duncan; Croker, Kevin S.; Zevin, Michael; Tarlé, Gregory; Faraoni, Valerio; Petty, Sara; Afonso, Jose; Fernandez, Nicolas; Nishimura, Kurtis A.; Pearson, Chris; Wang, Lingyu; Clements, David L.; Efstathiou, Andreas; Hatziminaoglou, Evanthia; Lacy, Mark; Mcpartland, Conor; Pitchford, Lura K.; Sakai, Nobuyuki; Weiner, Joel "Observational Evidence for Cosmological Coupling of Black Holes and its Implications for an Astrophysical Source of Dark Energy," *The Astrophysical Journal*, 944, L31, 2023.
- Farrah, Duncan; Petty, Sara; Croker, Kevin S.; Tarlé, Gregory; Zevin, Michael; Hatziminaoglou, Evanthia; Shankar, Francesco; Wang, Lingyu; Clements, David L.; Efstathiou, Andreas; Lacy, Mark; Nishimura, Kurtis A.; Afonso, Jose; Pearson, Chris; Pitchford, Lura K. "A Preferential Growth Channel for Supermassive Black Holes in Elliptical Galaxies at  $z > 2$ ," *The Astrophysical Journal*, 943, 133, 2023.
- Fawcett, V. A.; Alexander, D. M.; Brodzeller, A.; Edge, A. C.; Rosario, D. J.; Myers, A. D.; Aguilar, J.; Ahlen, S.; Alfarsy, R.; Brooks, D.; Canning, R.; Circosta, C.; Dawson, K.; De La Macorra, A.; Doel, P.; Fanning, K.; Font-Ribera, A.; Forero-Romero, J. E.; Gontcho A Gontcho, S.; Guy, J.; Harrison, C. M.; Honscheid, K.; Juneau, S.; Kehoe, R.; Kisner, T.; Kremin, A.; Landriau, M.; Manera, M.; Meisner, A. M.; Miquel, R.; Moustakas, J.; Nie, J.; Percival, W. J.; Poppett, C.; Pucha, R.; Rossi, G.; Schlegel, D.; Siudek, M.; Tarlé, G.; Weaver, B. A.; Zhou, Z.; Zou, H. "A striking relationship between dust extinction and radio detection in DESI QSOs: evidence for a dusty blow-out phase in red QSOs," *Monthly Notices of the Royal Astronomical Society*, 525, 5575, 2023.
- Fedele, D.; Bollati, F.; Lodato, G. "Kinematics signature of a giant planet in the disk of AS 209," *Astronomy and Astrophysics*, 672, A125, 2023.
- Federman, Samuel; Megeath, S. Thomas; Tobin, John J.; Sheehan, Patrick D.; Pokhrel, Riway; Habel, Nolan; Stutz, Amelia M.; Fischer, William J.; Hartmann, Lee; Stanke, Thomas; Narang, Mayank; Osorio, Mayra; Atmagulov, Prabhani; Rahatgaonkar, Rohan "300: An ACA 870  $\mu\text{m}$  Continuum Survey of Orion Protostars and Their Evolution," *The Astrophysical Journal*, 944, 49, 2023.
- Fedriani, Rubén; Tan, Jonathan C.; Telkamp, Zoie; Zhang, Yichen; Yang, Yao-Lun; Liu, Mengyao; De Buizer, James M.; Law, Chi-Yan; Beltran, Maria T.; Rosero, Viviana; Tanaka, Kei E. I.; Cosentino, Giuliana; Gorai, Prasanta; Farias, Juan; Staff, Jan E.; Whitney, Barbara "The SOFIA Massive (SOMA) Star Formation Survey. IV. Isolated Protostars," *The Astrophysical Journal*, 942, 7, 2023.
- Feeney-Johansson, A.; Purser, S. J. D.; Ray, T. P.; Carrasco-González, C.; Rodríguez-Kamenetzky, A.; Eislöffel, J.; Lim, J.; Galván-Madrid, R.; Lizano, S.; Rodríguez, L. F.; Shang, H.; Ho, P.; Hoare, M. "A high-resolution radio study of the L1551 IRS 5 and L1551 NE jets," *Astronomy and Astrophysics*, 677, A97, 2023.
- Fei, Qinyue; Wang, Ran; Molina, Juan; Shangguan, Jinyi; Ho, Luis C.; Bauer, Franz E.; Treister, Ezequiel "Dynamics of Molecular Gas in the Central Region of the Quasar I Zwicky 1," *The Astrophysical Journal*, 946, 45, 2023.
- Fender, R. P.; Mooley, K. P.; Motta, S. E.; Bright, J. S.; Williams, D. R. A.; Rushton, A. P.; Beswick, R. J.; Miller-Jones, J. C. A.; Kimura, M.; Isogai, K.; Kato, T. "Comprehensive coverage of particle acceleration and kinetic feedback from the stellar mass black hole V404 Cygni," *Monthly Notices of the Royal Astronomical Society*, 518, 1243, 2023.
- Feng, Yanan; Li, Xiaohu; Millar, Tom J.; Szczerba, Ryszard; Wang, Ke; Quan, Donghui; Qin, Shengli; Fang, Xuan; Tuo, Juan; Miao, Zhenzhen; Ma, Rong; Xu, Fengwei; Sun, Jingfei; Jiang, Biwei; Chang, Qiang; Yang, Jianchao; Hou, Gao-Lei; Li, Fangfang; Zhang, Yong "Photochemical origin of SiC2 in the circumstellar envelope of carbon-rich AGB stars revealed by ALMA," *Frontiers in Astronomy and Space Sciences*, 10, 1215642, 2023.
- Fernandez, Luis C.; Secret, Nathan J.; Johnson, Megan C.; Fischer, Travis C. "FRAMEx. IV. Mechanical Feedback from the Active Galactic Nucleus in NGC 3079," *The Astrophysical Journal*, 958, 61, 2023.
- Fernández-Ontiveros, J. A.; López-López, X.; Prieto, A. "Compact jets dominate the continuum emission in low-luminosity active galactic nuclei," *Astronomy and Astrophysics*, 670, A22, 2023.
- Ferreira, Ricardo Z.; Notari, Alessio; Pujolàs, Oriol; Rompineve, Fabrizio "Gravitational waves from domain walls in Pulsar Timing Array datasets," *Journal of Cosmology and Astro-Particle Physics*, 2023, 1, 2023.
- Ferrer Asensio, J.; Spezzano, S.; Coudert, L. H.; Lattanzi, V.; Endres, C. P.; Jørgensen, J. K.; Caselli, P. "Millimetre and sub-millimetre spectroscopy of doubly deuterated acetaldehyde (CHD<sub>2</sub>CHO) and first detection towards IRAS 16293-2422," *Astronomy and Astrophysics*, 670, A177, 2023.
- Felder, Catherine E.; Jones, Michael G.; Sand, David J.; Bennet, Paul; Crnojević, Denija; Karunakaran, Ananthan; Mutlu-Pakdil, Burçin; Spekkens, Kristine "The Disturbed and Globular-cluster-rich Ultradiffuse Galaxy UGC 9050-Dw1," *The Astrophysical Journal*, 954, L39, 2023.
- Fijma, S.; Van Den Eijnden, J.; Degenaar, N.; Russell, T. D.; Miller-Jones, J. C. A. "Evaluating the jet/accretion coupling of Aql X-1: probing the contribution of accretion flow spectral components," *Monthly Notices of the Royal Astronomical Society*, 521, 4490, 2023.
- Filipović, Miroslav D.; Dai, Shi; Arbutina, Bojan; Hurley-Walker, Natasha; Brose, Robert; Becker, Werner; Sano, Hidetoshi; Urošević, Dejan; Jarrett, T. H.; Hopkins, Andrew M.; Alsaberi, Rami Z. E.; Alsulami, R.; Bordiu, Cristobal; Ball, Brianna; Bufano, Filomena; Burger-Scheidlin, Christopher; Crawford, Evan; English, Jayanne; Haberl, Frank; Ingallinera, Adriano; Kapinska, Anna D.; Kavanagh, Patrick J.; Koribalski, Bärbel S.; Kothes, Roland; Lazarević, Sanja; Mackey, Jonathan; Rowell, Gavin; Leahy, Denis; Loru, Sara; Macgregor, Peter J.; Nicastro, Luciano; Norris, Ray P.; Riggio, Simone; Sasaki, Manami; Stupar, Milorad; Trigilio, Corrado; Umana, Grazia; Vernstrom, Tessa; Vukotić, Branislav "EMU Detection of a Large and Low Surface Brightness Galactic SNR G288.8-6.3," *The Astronomical Journal*, 166, 149, 2023.
- Fiore, W.; Levin, L.; McLaughlin, M. A.; Anumalapudi, A.; Kaplan, D. L.; Swiggum, J. K.; Agazie, G. Y.; Bavisotto, R.; Chawla, P.; Decesar, M. E.; Dolch, T.; Fonseca, E.; Kaspi, V. M.; Komassa, Z.; Kondratiev, V. I.; Van Leeuwen, J.; Lewis, E. F.; Lynch, R. S.; Mcewen, A. E.; Mundorf, R.; Al Noori, H.; Parent, E.; Pleunis, Z.; Ransom, S. M.; Siemens, X.; Spiewak, R.; Stairs, I. H.; Surnis, M.; Tobin, T. J. "The Green Bank North Celestial Cap Survey. VIII. 21 New Pulsar Timing Solutions," *The Astrophysical Journal*, 956, 40, 2023.
- Fischer, Travis C.; Johnson, Megan C.; Secret, Nathan J.; Crenshaw, D. Michael; Kraemer, Steven B. "No Small-scale Radio Jets Here: Multi-epoch Observations of Radio Continuum Structures in NGC 1068 with the VLBA," *The Astrophysical Journal*, 953, 87, 2023.
- Flores, Christian; Ohashi, Nagayoshi; Tobin, John J.; Jørgensen, Jes K.; Takakuwa, Shigehisa; Li, Zhi-Yun; Lin, Zhe-Yu; Daniel, Van'T Hoff, Merel L. R.; Plunkett, Adele L.; Yamato, Yoshihide; Sai (Insa Choi), Jinshi; Koch, Patrick M.; Yen, Hsi-Wei; Aikawa, Yuri; Aso, Yusuke; De Gregorio-Monsalvo, Itziar; Kido, Miyu; Kwon, Woojin; Lee, Jeong-Eun; Lee, Chang Won; Looney, Leslie W.; Santamaría-Miranda, Alejandro; Sharma, Rajeeb; Thieme, Travis J.; Williams, Jonathan P.; Han, Ilseung; Narayanan, Suchitra; Lai, Shih-Ping "Early Planet Formation in Embedded Disks (eDisk). XII. Accretion Streamers, Protoplanetary Disk, and Outflow in the Class I Source Oph IRS 63," *The Astrophysical Journal*, 958, 98, 2023.
- Flores-Rivera, Lizxandra; Flock, Mario; Kurtovic, Nicolás T.; Husemann, Bernd; Banzatti, Andrea; Ringqvist, Simon C.; Kamann, Sebastian; Müller, André; Fendt, Christian; García Lopez, Rebeca; Marleau, Gabriel-Dominique; Henning, Thomas; Carrasco-González, Carlos; Van Boekel, Roy; Keppler, Miriam; Launhardt, Ralf; Aoyama, Yuhiko "Forbidden emission lines in protostellar outflows and jets with MUSE," *Astronomy and Astrophysics*, 670, A126, 2023.
- France, Kevin; Arulanantham, Nicole; Maloney, Erin; Cauley, P. Wilson; Abraham, P.; Alcalá, Juan M.; Campbell-White, Justyn; Fiorellino, Eleonora; Herczeg, Gregory J.; Nisini, Brunella; Vioque, Miguel "The Radial Distribution and Excitation of H<sub>2</sub> around Young Stars in the HST-

- ULLYSES Survey," *The Astronomical Journal*, 166, 67, 2023.
- Frank, Emily; Stark, David V.; Masters, Karen; Roy, Namrata; Riffel, Rogério; Lacerna, Ivan; Riffel, Rogemar A.; Bizyaev, Dmitry "The H I content of red geyser galaxies," *Monthly Notices of the Royal Astronomical Society*, 519, 3312, 2023.
- Freeman, P.; Bottinelli, S.; Plume, R.; Caux, E.; Monaghan, C.; Mookerjee, B. "Parsec scales of carbon chain and complex organic molecules in AFGL 2591 and IRAS 20126," *Astronomy and Astrophysics*, 678, A18, 2023.
- French, K. Decker; Smercina, Adam; Rowlands, Kate; Tripathi, Akshat; Zabludoff, Ann I.; Smith, John-David T.; Narayanan, Desika; Yang, Yujin; Shirley, Yancy; Alatalo, Katey "The State of the Molecular Gas in Post-starburst Galaxies," *The Astrophysical Journal*, 942, 25, 2023.
- Fudamoto, Y.; Inoue, A. K.; Sugahara, Y. "Estimating dust temperature and Far-IR luminosity of high-redshift galaxies using ALMA single-band continuum observations," *Monthly Notices of the Royal Astronomical Society*, 521, 2962, 2023.
- Fujimoto, Seiji; Finkelstein, Steven L.; Burgarella, Denis; Carilli, Chris L.; Buat, Véronique; Casey, Caitlin M.; Ciesla, Laure; Tacchella, Sandro; Zavala, Jorge A.; Brammer, Gabriel; Fudamoto, Yoshinobu; Ouchi, Masami; Valentino, Francesco; Cooper, M. C.; Dickinson, Mark; Franco, Maximilien; Gialavisco, Mauro; Hutchison, Taylor A.; Kartaltepe, Jeyhan S.; Koekemoer, Anton M.; Kojima, Takashi; Larson, Rebecca L.; Murphy, E. J.; Papovich, Casey; Pérez-González, Pablo G.; Somerville, Rachel S.; Yoon, Ilsang; Wilkins, Stephen M.; Akins, Hollis; Amorín, Ricardo O.; Haro, Pablo Arrabal; Bagley, Micaela B.; Chworowsky, Katherine; Cleri, Nikko J.; Cooper, Olivia R.; Costantin, Luca; Daddi, Emanuele; Ferguson, Henry C.; Grogin, Norman A.; Jiménez-Andrade, E. F.; Juneau, Stéphanie; Kirkpatrick, Allison; Kocevski, Dale D.; Le Bail, Aurélien; Long, Arianna; Lucas, Ray A.; Magnelli, Benjamin; McKinney, Jed; Rose, Caitlin; Seillé, Lise-Marie; Simons, Raymond C.; Weiner, Benjamin J.; Yung, L. Y. Aaron "ALMA FIR View of Ultra-high-redshift Galaxy Candidates at  $z \sim 11-17$ : Blue Monsters or Low- $z$  Red Interlopers?," *The Astrophysical Journal*, 955, 130, 2023.
- Fujita, Yutaka; Izumi, Takuma; Kawakatu, Nozomu; Nagai, Hiroshi; Hirasawa, Ryo; Ikeda, Yu "The correlation between the 500 pc scale molecular gas masses and AGN powers for massive elliptical galaxies," *Publications of the Astronomical Society of Japan*, 75, 925, 2023.
- Fukaya, Sakiko; Shinnaga, Hiroko; Furuya, Ray S.; Tomisaka, Kohji; Machida, Masahiro N.; Harada, Naoto "Twisted magnetic field in star formation processes of L1521 F revealed by submillimeter dual-band polarimetry using the James Clerk Maxwell Telescope," *Publications of the Astronomical Society of Japan*, 75, 120, 2023.
- Furtak, Lukas J.; Mainali, Ramesh; Zitrin, Adi; Plat, Adèle; Fujimoto, Seiji; Donahue, Megan; Nelson, Erica J.; Bauer, Franz E.; Uematsu, Ryosuke; Caminha, Gabriel B.; Andrade-Santos, Felipe; Bradley, Larry D.; Caputi, Karina I.; Charlot, Stéphane; Chevillard, Jacopo; Coe, Dan; Curtis-Lake, Emma; Espada, Daniel; Frye, Brenda L.; Knudsen, Kirsten K.; Koekemoer, Anton M.; Kohno, Kotaro; Kokorev, Vasily; Laporte, Nicolas; Lee, Minju M.; Lemaux, Brian C.; Magdis, Georgios E.; Sharon, Keren; Stark, Daniel P.; Su, Yuanyuan; Suess, Katherine A.; Ueda, Yoshihiro; Umehata, Hideki; Vidal-García, Alba; Wu, John F. "A variable active galactic nucleus at  $z = 2.06$  triply-imaged by the galaxy cluster MACS J0035.4-2015," *Monthly Notices of the Royal Astronomical Society*, 522, 5142, 2023.
- Furtak, Lukas J.; Zitrin, Adi; Plat, Adèle; Fujimoto, Seiji; Wang, Bingjie; Nelson, Erica J.; Labbé, Ivo; Bezanson, Rachel; Brammer, Gabriel B.; Van Dokkum, Pieter; Endsley, Ryan; Glazebrook, Karl; Greene, Jenny E.; Leja, Joel; Price, Sedona H.; Smit, Renske; Stark, Daniel P.; Weaver, John R.; Whitaker, Katherine E.; Atek, Hakim; Chevillard, Jacopo; Curtis-Lake, Emma; Dayal, Pratika; Feltre, Anna; Franx, Marijn; Fudamoto, Yoshinobu; Marchesini, Danilo; Mowla, Lamiya A.; Pan, Richard; Suess, Katherine A.; Vidal-García, Alba; Williams, Christina C. "JWST UNCOVER: Extremely Red and Compact Object at  $z_{\text{phot}} \sim 7.6$  Triply Imaged by A2744," *The Astrophysical Journal*, 952, 142, 2023.
- Gallimore, Jack F.; Impellizzeri, C. M. Violette "High-sensitivity Observations of the H<sub>2</sub>O Megamasers of NGC 1068: Precise Astrometry and Detailed Kinematics," *The Astrophysical Journal*, 951, 109, 2023.
- Galloway-Sprietsma, Maria; Bae, Jaehan; Teague, Richard; Benisty, Myriam; Facchini, Stefano; Aikawa, Yuri; Alarcón, Felipe; Andrews, Sean M.; Bergin, Edwin; Cataldi, Gianni; Cleeves, L. Ilse; Czekala, Ian; Guzmán, Viviana V.; Huang, Jane; Law, Charles J.; Le Gal, Romane; Liu, Yao; Long, Feng; Ménard, François; Öberg, Karin I.; Walsh, Catherine; Wilner, David J. "Molecules with ALMA at Planet-forming Scales (MAPS). Complex Kinematics in the AS 209 Disk Induced by a Forming Planet and Disk Winds," *The Astrophysical Journal*, 950, 147, 2023.
- Galván-Madrid, Roberto; Zhang, Qizhou; Izquierdo, Andrés; Law, Charles J.; Peters, Thomas; Keto, Eric; Liu, Haiyu Baobab; Ho, Paul T. P.; Ginsburg, Adam; Carrasco-González, Carlos "Clustered Formation of Massive Stars within an Ionized Rotating Disk," *The Astrophysical Journal*, 942, L7, 2023.
- Gangopadhyay, Anjasha; Maeda, Keiichi; Singh, Avinash; Nayana, A. J.; Nakaoka, Tatsuya; Kawabata, Koji S.; Taguchi, Kenta; Singh, Mridweeka; Chandra, Poonam; Ryder, Stuart D.; Dastidar, Raya; Yamanaka, Masayuki; Kawabata, Miho; Alsaberi, Rami Z. E.; Dukiya, Naveen; Teja, Rishabh Singh; Ailawadhi, Bhavya; Dutta, Anirban; Sahu, D. K.; Moriya, Takashi J.; Misra, Kuntal; Tanaka, Masaomi; Chevalier, Roger; Tominaga, Nozomu; Uno, Kohki; Imazawa, Ryo; Hamada, Taisei; Hori, Tomoya; Isogai, Keisuke "Bridging between Type IIb and Ib Supernovae: SN IIb 2022crv with a Very Thin Hydrogen Envelope," *The Astrophysical Journal*, 957, 100, 2023.
- Gao, X. Y.; Yuan, Z. S.; Han, J. L.; Wen, Z. L.; Shan, S. S. "Three New Spiral Galaxies with Active Nuclei Producing Double Radio Lobes," *Research in Astronomy and Astrophysics*, 23, 35005, 2023.
- García-Barreto, J. Antonio; Momjian, Emmanuel "H I 21 cm Extended Structures to the Northeast and Southwest of NGC 5595: VLA Observations of the Disk Galaxy Pair NGC 5595 and NGC 5597," *The Astronomical Journal*, 165, 240, 2023.
- García-Rodríguez, A.; Usero, A.; Leroy, A. K.; Bigiel, F.; Jiménez-Donaire, M. J.; Liu, D.; Querejeta, M.; Saito, T.; Schinnerer, E.; Barnes, A.; Belfiore, F.; Bešlić, I.; Cao, Y.; Chevance, M.; Dale, D. A.; Den Brok, J. S.; Eibensteiner, C.; García-Burillo, S.; Glover, S. C. O.; Klessen, R. S.; Pety, J.; Puschign, J.; Rosolowsky, E.; Sandstrom, K.; Sormani, M. C.; Teng, Y.-H.; Williams, T. G. "Sub-kiloparsec empirical relations and excitation conditions of HCN and HCO<sup>+</sup> J = 3-2 in nearby star-forming galaxies," *Astronomy and Astrophysics*, 672, A96, 2023.
- Garduño, L. E.; Zaragoza-Cardiel, J.; Lara-López, M. A.; Zinchenko, I. A.; Zerbo, M. C.; De Rossi, M. E.; Fritz, Jacopo; Dib, Sami; Pilyugin, L. S.; Sánchez-Cruces, M.; Heesen, V.; O'Sullivan, S. P.; López-Cruz, O.; Valardi, M.; Rosado, Margarita "Metal-THINGS: a panchromatic analysis of the local scaling relationships of the dwarf irregular galaxy NGC 1569," *Monthly Notices of the Royal Astronomical Society*, 526, 2479, 2023.
- Gaudel, Mathilde; Orkisz, Jan H.; Gerin, Maryvonne; Pety, Jérôme; Roueff, Antoine; Marchal, Antoine; Levrier, François; Miville-Deschênes, Marc-Antoine; Goicoechea, Javier R.; Roueff, Evelyne; Le Petit, Franck; De Souza Magalhaes, Victor; Palud, Pierre; Santa-Maria, Miriam G.; Vono, Maxime; Bardeau, Sébastien; Bron, Emeric; Chainais, Pierre; Chanutot, Jocelyn; Gratier, Pierre; Guzman, Viviana; Hughes, Annie; Kainulainen, Jouni; Languignon, David; Le Bourlot, Jacques; Liszt, Harvey; Öberg, Karin; Peretto, Nicolas; Sievers, Albrecht; Tremblin, Pascal "Gas kinematics around filamentary structures in the Orion B cloud," *Astronomy and Astrophysics*, 670, A59, 2023.
- Geach, J. E.; Lopez-Rodríguez, E.; Doherty, M. J.; Chen, Jianhang; Ivison, R. J.; Bendo, G. J.; Dye, S.; Coppin, K. E. K. "Polarized thermal emission from dust in a galaxy at redshift 2.6," *Nature*, 621, 483, 2023.
- Ghodsí Yengejeh, Mina; Fakhry, Saeed; T. Firouzjaee, Javad; Fathi, Hojatollah "The integrated Sachs-Wolfe effect in interacting dark matter-dark energy models," *Physics of the Dark Universe*, 39, 101144, 2023.
- Ghosh, Ritesh; Laha, Sibasis; Meyer, Eileen; Roychowdhury, Agniya; Yang,

## APPENDIX A: PUBLICATIONS

- Xiaolong; Acosta-Pulido, J. A.; Rakshit, Suvendu; Pandey, Shivangi; González, Josefa Becerra; Behar, Ehud; Gallo, Luigi C.; Panessa, Francesca; Bianchi, Stefano; La Franca, Fabio; Sceph, Nicolas; Begelman, Mitchell C.; Longinotti, Anna Lia; Lusso, Elisabeta; Oates, Samantha; Nicholl, Matt; Cenke, S. Bradley; O'Connor, Brendan; Hammerstein, Erica; Jose, Jincen; Gabányi, Krisztina Éva; Ricci, Federica; Chattopadhyay, Sabyasachi "A Reemerging Bright Soft X-Ray State of the Changing-look Active Galactic Nucleus 1ES 1927+654: A Multiwavelength View," *The Astrophysical Journal*, 955, 3, 2023.
- Ghosh, Salmoli; Kharb, P.; Baghel, J.; Silpa, S. "PG 1004+130: Hybrid Morphology Source or a Restarted FR II? A uGMRT Polarimetric Investigation," *The Astrophysical Journal*, 958, 71, 2023.
- Giarratana, S.; Giroletti, M.; Spingola, C.; Migliori, G.; Belladitta, S.; Pedani, M. "Multi-scale VLBI observations of the candidate host galaxy of GRB 200716C," *Astronomy and Astrophysics*, 670, A35, 2023.
- Gieser, C.; Beuther, H.; Semenov, D.; Ahmadi, A.; Henning, Th.; Wells, M. R. A. "Physical and chemical complexity in high-mass star-forming regions with ALMA. I. Overview and evolutionary trends of physical properties," *Astronomy and Astrophysics*, 674, A160, 2023.
- Gillman, Steven; Gullberg, Bitten; Brammer, Gabe; Vijayan, Aswin P.; Lee, Minju; Blázquez, David; Brinch, Malte; Greve, Thomas R.; Jermann, Iris; Jin, Shuowen; Kokorev, Vasily; Liu, Lijie; Magdis, Georgios; Rizzo, Francesca; Valentino, Francesco "Sub-millimetre galaxies with Webb. Near-infrared counterparts and multi-wavelength morphology," *Astronomy and Astrophysics*, 676, A26, 2023.
- Ginsburg, Adam; Mcguire, Brett A.; Sanhueza, Patricio; Olguin, Fernando; Maud, Luke T.; Tanaka, Kei E. I.; Zhang, Yichen; Beuther, Henrik; Indriolo, Nick "Salt-bearing Disk Candidates around High-mass Young Stellar Objects," *The Astrophysical Journal*, 942, 66, 2023.
- Giovannini, G.; Baldi, R. D.; Capetti, A.; Giroletti, M.; Lico, R. "Jets in FRO radio galaxies," *Astronomy and Astrophysics*, 672, A104, 2023.
- Giulietti, Marika; Lapi, Andrea; Massardi, Marcella; Behiri, Meriem; Torsello, Martina; D'Amato, Quirino; Ronconi, Tommaso; Perrotta, Francesca; Bressan, Alessandro "ALMA Resolves the First Strongly Lensed Optical/Near-IR-dark Galaxy," *The Astrophysical Journal*, 943, 151, 2023.
- Glikman, Eilat; Langgins, Rachel; Johnstone, Makoto A.; Yoon, Ilsang; Comerford, Julia M.; Simmons, Brooke D.; Stacey, Hannah; Lacy, Mark; O'Meara, John M. "A Candidate Dual QSO at Cosmic Noon," *The Astrophysical Journal*, 951, L18, 2023.
- Glikman, Eilat; Rusu, Cristian E.; Chen, Geoff C.-F.; Chan, James Hung-Hsu; Spingola, Cristiana; Stacey, Hannah; Mckean, John; Berghea, Ciprian T.; Djorgovski, S. G.; Graham, Matthew J.; Stern, Daniel; Urrutia, Tanya; Lacy, Mark; Secrest, Nathan J.; O'Meara, John M. "A Highly Magnified Gravitationally Lensed Red QSO at  $z = 2.5$  with a Significant Flux Ratio Anomaly," *The Astrophysical Journal*, 943, 25, 2023.
- Gloude-mans, A. J.; Saxena, A.; Intema, H.; Callingham, J. R.; Duncan, K. J.; Röttgering, H. J. A.; Belladitta, S.; Hardcastle, M. J.; Harikane, Y.; Spingola, C. "No strong radio absorption detected in the low-frequency spectra of radio-loud quasars at  $z > 5.6$ ," *Astronomy and Astrophysics*, 678, A128, 2023.
- Goddy, Julian S.; Stark, David V.; Masters, Karen L.; Bundy, Kevin; Drory, Niv; Law, David R. "A Comparison of the Baryonic Tully-Fisher Relation in MaNGA and IllustrisTNG," *Monthly Notices of the Royal Astronomical Society*, 520, 3895, 2023.
- Golay, Walter W.; Mutel, Robert L.; Lipman, Dani; Güdel, Manuel "A search for thermal gyro-synchrotron emission from hot stellar coronae," *Monthly Notices of the Royal Astronomical Society*, 522, 1394, 2023.
- Golden-Marx, Emmet; Moravec, E.; Shen, L.; Cai, Z.; Blanton, E. L.; Gendron-Marsolais, M. L.; Röttgering, H. J. A.; Van Weeren, R. J.; Buiten, V.; Grumitt, R. D. P.; Golden-Marx, J.; Pinjarkar, S.; Tang, H. "The High-redshift Clusters Occupied by Bent Radio AGN (COBRA) Survey: Investigating the Role of Environment on Bent Radio AGNs Using LOFAR," *The Astrophysical Journal*, 956, 87, 2023.
- Gómez, José F.; Torrelles, José M.; Girart, Josep M.; Surcis, Gabriele; Kim, Jeong-Sook; Cantó, Jorge; Anglada, Guillem; Curiel, Salvador; Vlemmings, Wouter H. T.; Carrasco-González, Carlos; Rodríguez-Kamenetzky, Adriana R.; Kim, Soon-Wook; Goddi, Ciriaco; Van Langevelde, Huib J.; Sanchez-Monge, Álvaro "An SiO Toroid and Wide-angle Outflow Associated with the Massive Protostar W75N(B)-VLA2," *The Astrophysical Journal*, 956, L45, 2023.
- Gong, Hang; Urquhart, Ryan; Vinokurov, Alexandr; Bai, Yu; Cabrera-Lavers, Antonio; Fabrika, Sergei; Wang, Liang; Liu, Jifeng "Discovery of an X-Ray Photoionized Optical Nebula and a Radio Nebula Associated with the ULX NGC 4861 X-1," *The Astrophysical Journal*, 958, 24, 2023.
- Gong, Y.; Du, F. J.; Henkel, C.; Jacob, A. M.; Belloche, A.; Wang, J. Z.; Menten, K. M.; Yang, W.; Quan, D. H.; Bop, C. T.; Ortiz-León, G. N.; Tang, X. D.; Rugel, M. R.; Liu, S. "Protonated hydrogen cyanide as a tracer of pristine molecular gas," *Astronomy and Astrophysics*, 679, A39, 2023.
- Gong, Y.; Ortiz-León, G. N.; Rugel, M. R.; Menten, K. M.; Brunthaler, A.; Wyrowski, F.; Henkel, C.; Beuther, H.; Dzib, S. A.; Urquhart, J. S.; Yang, A. Y.; Pandian, J. D.; Dokara, R.; Veena, V. S.; Nguyen, H.; Medina, S. -N. X.; Cotton, W. D.; Reich, W.; Winkel, B.; Müller, P.; Skretas, I.; Csengeri, T.; Khan, S.; Cheema, A. "A global view on star formation: The GLOSTAR Galactic plane survey. VIII. Formaldehyde absorption in Cygnus X," *Astronomy and Astrophysics*, 678, A130, 2023.
- Goodwin, A. J.; Alexander, K. D.; Miller-Jones, J. C. A.; Bietenholz, M. F.; Van Velzen, S.; Anderson, G. E.; Berger, E.; Cendes, Y.; Chornock, R.; Coppejans, D. L.; Eftekhari, T.; Gezari, S.; Laskar, T.; Ramirez-Ruiz, E.; Saxton, R. "A radio-emitting outflow produced by the tidal disruption event AT2020vwl," *Monthly Notices of the Royal Astronomical Society*, 522, 5084, 2023.
- Goodwin, A. J.; Miller-Jones, J. C. A.; Van Velzen, S.; Bietenholz, M.; Greenland, J.; Cenke, B.; Gezari, S.; Horesh, A.; Sivakoff, G. R.; Yan, L.; Yu, W.; Zhang, X. "Radio observations of the tidal disruption event AT2020opy: a luminous non-relativistic outflow encountering a dense circumnuclear medium," *Monthly Notices of the Royal Astronomical Society*, 518, 847, 2023.
- Gopal-Krishna, Wiita, Paul J.; Joshi, Ravi; Patra, Dushmantha "A physically-motivated perspective of Fanaroff-Riley classification of radio galaxies," *Journal of Astrophysics and Astronomy*, 44, 44, 2023.
- Gorce, Adélie; Ganjam, Samskruthi; Liu, Adrian; Murray, Steven G.; Abdurashidova, Zara; Adams, Tyrone; Aguirre, James E.; Alexander, Paul; Ali, Zaki S.; Baartman, Rushelle; Balfour, Yanga; Beardsley, Adam P.; Bernardi, Gianni; Billings, Tashalee S.; Bowman, Judd D.; Bradley, Richard F.; Bull, Philip; Burba, Jacob; Carey, Steven; Carilli, Chris L.; Cheng, Carina; Deboer, David R.; Acedo, Eloy De Lera; Dexter, Matt; Dillon, Joshua S.; Eksteen, Nico; Ely, John; Ewall-Wice, Aaron; Fagnoni, Nicolas; Fritz, Randall; Furlanetto, Steven R.; Gale-Sides, Kingsley; Glendenning, Brian; Gorthi, Deepthi; Greig, Bradley; Grobelaar, Jasper; Halday, Ziyaad; Hazelton, Bryna J.; Hewitt, Jacqueline N.; Hickish, Jack; Jacobs, Daniel C.; Julius, Austin; Kariseb, Maccalvin; Kern, Nicholas S.; Kerrigan, Joshua; Kittiwisit, Piyana; Kohn, Saul A.; Kolopanis, Matthew; Lanman, Adam; La Plante, Paul; Loots, Anita; Macmahon, David Harold Edward; Malan, Lourence; Malgas, Cresshim; Malgas, Keith; Marero, Bradley; Martinot, Zachary E.; Mesinger, Andrei; Molewa, Mathakane; Morales, Miguel F.; Mosiane, Tshogefalang; Neben, Abraham R.; Nikolic, Bojan; Nuwegeld, Hans; Parsons, Aaron R.; Patra, Nipanjana; Pieterse, Samantha; Pober, Jonathan C.; Razavi-Ghods, Nima; Robnett, James; Rosie, Kathryn; Sims, Peter; Swarts, Hilton; Thyagarajan, Nithyanandan; Van Wyngaerden, Pieter; Williams, Peter K. G.; Zheng, Haoxuan "Impact of instrument and data characteristics in the interferometric reconstruction of the 21 cm power spectrum," *Monthly Notices of the Royal Astronomical Society*, 520, 375-391, 2023.
- Gordon, David; De Witt, Aletha; Jacobs, Christopher S. "Position and Proper Motion of Sagittarius A\* in the ICRF3 Frame from VLBI Absolute Astrometry," *The Astronomical Journal*, 165, 49, 2023.
- Gordon, Yjan A.; O'Dea, Christopher P.; Baum, Stefi A.; Bechtol, Keith; Duggal, Chetna; Ferguson, Peter S. "Compact Steep Spectrum Radio Sources with Enhanced Star Formation Are Smaller Than 10 kpc," *The*



- Astrophysical Journal, 948, L9, 2023.
- Gordon, Yjan A.; Rudnick, Lawrence; Andernach, Heinz; Morabito, Leah K.; O'Dea, Christopher P.; Achong, Kaylan-Marie; Baum, Stefi A.; Bayona-Figueroa, Caryelis; Hooper, Eric J.; Mingo, Beatriz; Morris, Melissa E.; Vantyghem, Adrian N. "A Quick Look at the 3 GHz Radio Sky. II. Hunting for DRAGNs in the VLA Sky Survey," *The Astrophysical Journal Supplement Series*, 267, 37, 2023.
- Gramze, Savannah R.; Ginsburg, Adam; Meier, David S.; Ott, Juergen; Shirley, Yancy; Sormani, Mattia C.; Svoboda, Brian E. "Evidence of a Cloud-Cloud Collision from Overshooting Gas in the Galactic Center," *The Astrophysical Journal*, 959, 93, 2023.
- Grant, Sierra L.; Stapper, Lucas M.; Hogerheijde, Michiel R.; Van Dishoeck, Ewine F.; Brittain, Sean; Vioque, Miguel "The  $\dot{M}$  -  $M$  disk Relationship for Herbig Ae/Be Stars: A Lifetime Problem for Disks with Low Masses?," *The Astronomical Journal*, 166, 147, 2023.
- Griese, Florian; Kummer, Janis; Connor, Patrick L. S.; Brüggem, Marcus; Rustige, Lennart "FIRST radio galaxy data set containing curated labels of classes FRI, FRII, compact and bent," *Data in Brief*, 47, 108974, 2023.
- Gross, Arran C.; Chen, Yu-Ching; Foord, Adi; Liu, Xin; Shen, Yue; Oguri, Masamune; Goulding, Andy; Hwang, Hsiang-Chih; Zakamska, Nadia L.; Ma, Yilun; Nolan, Liam "Varstrometry for Off-nucleus and Dual Subkiloparsec Active Galactic Nuclei (VODKA): Investigating the Nature of SDSS J0823+2418 at  $z = 1.81$ , A Likely Lensed Quasar," *The Astrophysical Journal*, 956, 117, 2023.
- Gross, Arran C.; Fu, Hai; Myers, A. D.; Djorgovski, S. G.; Steffen, Joshua L.; Wrobel, J. M. "Testing the Radio-selection Method of Dual Active Galactic Nuclei in the Stripe 82 Field," *The Astrophysical Journal*, 945, 73, 2023.
- Grundy, J. A.; Wong, O. I.; Lee-Waddell, K.; Seymour, N.; For, B.-Q.; Murugesan, C.; Koribalski, B. S.; Madrid, J. P.; Rhee, J.; Westmeier, T. "WALLABY pre-pilot survey: Radio continuum properties of the Eridanus supergroup," *Publications of the Astronomical Society of Australia*, 40, e012, 2023.
- Guerra, Jordan A.; Lopez-Rodriguez, Enrique; Chuss, David T.; Butterfield, Natalie O.; Schmelz, Joan T. "The Strength of the Sheared Magnetic Field in the Galactic's Circumnuclear Disk," *The Astronomical Journal*, 166, 37, 2023.
- Guerrero, Andrea; Nagar, Neil; Kohno, Kotaro; Fujimoto, Seiji; Kokorev, Vasily; Brammer, Gabriel; Jolly, Jean-Baptiste; Knudsen, Kirsten; Sun, Fengwu; Bauer, Franz E.; Caminha, Gabriel B.; Caputi, Karina; Neumann, Gerald; Orellana-González, Gustavo; Cerulo, Pierluigi; González-López, Jorge; Laporte, Nicolas; Koekemoer, Anton M.; Ao, Yiping; Espada, Daniel; Arancibia, Alejandra M. Muñoz "ALMA Lensing Cluster Survey: average dust, gas, and star-formation properties of cluster and field galaxies from stacking analysis," *Monthly Notices of the Royal Astronomical Society*, 526, 2423, 2023.
- Guevara Gómez, Juan Camilo; Jafarzadeh, Shahin; Wedemeyer, Sven; Grant, Samuel D. T.; Eklund, Henrik; Szydlarski, Mikołaj "The Sun at millimeter wavelengths. IV. Magnetohydrodynamic waves in small-scale bright features," *Astronomy and Astrophysics*, 671, A69, 2023.
- Gupta, A.; Miotello, A.; Manara, C. F.; Williams, J. P.; Facchini, S.; Beccari, G.; Birnstiel, T.; Ginski, C.; Hacar, A.; Küffmeier, M.; Testi, L.; Tychoniec, L.; Yen, H.-W. "Reflections on nebulae around young stars. A systematic search for late-stage infall of material onto Class II disks," *Astronomy and Astrophysics*, 670, L8, 2023.
- Gururajan, G.; Bethermin, M.; Sulzenauer, N.; Theulé, P.; Spilker, J. S.; Aravena, M.; Chapman, S. C.; Gonzalez, A.; Greve, T. R.; Narayanan, D.; Reuter, C.; Vieira, J. D.; Weiss, A. "Observations of neutral carbon in 29 high- $z$  lensed dusty star-forming galaxies and the comparison of gas mass tracers," *Astronomy and Astrophysics*, 676, A89, 2023.
- Guzmán-Díaz, J.; Montesinos, B.; Mendigutía, I.; Kama, M.; Meeus, G.; Vioque, M.; Oudmaijer, R. D.; Villaver, E. "Relation between metallicities and spectral energy distributions of Herbig Ae/Be stars. A potential link with planet formation," *Astronomy and Astrophysics*, 671, A140, 2023.
- H. E. S. S. Collaboration; Aharonian, F.; Ait Benkhali, F.; Arcaro, C.; Aschersleben, J.; Backes, M.; Barbosa Martins, V.; Batzofin, R.; Becherini, Y.; Berge, D.; Bernlöhr, K.; Bi, B.; Böttcher, M.; Boisson, C.; Bolmont, J.; Borowska, J.; Bradascio, F.; Breuhaus, M.; Brose, R.; Brun, F.; Bruno, B.; Bulik, T.; Burger-Scheidlin, C.; Bylund, T.; Caroff, S.; Casanova, S.; Cecil, R.; Celic, J.; Cerruti, M.; Chand, T.; Chandra, S.; Chen, A.; Chibueze, J.; Chibueze, O.; Cotter, G.; Damascene Mbarubucyeye, J.; Djannati-Ataï, A.; Egberts, K.; Ermenwein, J.-P.; Fichtel De Clairfontaine, G.; Filipovic, M.; Fontaine, G.; Föbbling, M.; Funk, S.; Gabici, S.; Ghafourzadeh, S.; Giavitto, G.; Glawion, D.; Glicenstein, J. F.; Goswami, P.; Grolleron, G.; Grondin, M.-H.; Haerer, L.; Haupt, M.; Hermann, G.; Hinton, J. A.; Holch, T. L.; Horns, D.; Jamrozy, M.; Jankowsky, F.; Joshi, V.; Jung-Richardt, I.; Kasai, E.; Katarzyński, K.; Khatoun, R.; Khélifi, B.; Kluźniak, W.; Komin, Nu.; Kosack, K.; Kostunin, D.; Lang, R. G.; Le Stum, S.; Leiti, F.; Lemièrre, A.; Lemoine-Goumard, M.; Lenain, J.-P.; Leuschner, F.; Lohse, T.; Luashvili, A.; Lypova, I.; Mackey, J.; Malyshev, D.; Malyshev, D.; Marandon, V.; Marchegiani, P.; Marcowith, A.; Marinos, P.; Martí-Devesa, G.; Marx, R.; Meyer, M.; Mitchell, A.; Moderski, R.; Mohrmann, L.; Montanari, A.; Moulin, E.; Müller, J.; Nakashima, K.; De Naurois, M.; Niemiec, J.; Priyana Noel, A.; O'Brien, P.; Ohm, S.; Olivera-Nieto, L.; De Ona Wilhelmi, E.; Panny, S.; Panter, M.; Parsons, R. D.; Peron, G.; Pita, S.; Prokhorov, D. A.; Prokoph, H.; Pühlhofer, G.; Punch, M.; Quirrenbach, A.; Reichherzer, P.; Reimer, A.; Reimer, O.; Renaud, M.; Rieger, F.; Rowell, G.; Rudak, B.; Ruiz-Velasco, E.; Sahakian, V.; Salzmann, H.; Sanchez, D. A.; Santangelo, A.; Sasaki, M.; Schäfer, J.; Schüssler, F.; Schwanke, U.; Shapopi, J. N. S.; Sol, H.; Specovius, A.; Spencer, S.; Stawarz, L.; Steenkamp, R.; Steinmassl, S.; Steppa, C.; Sushch, I.; Suzuki, H.; Takahashi, T.; Tanaka, T.; Taylor, A. M.; Terrier, R.; Tsiour, M.; Tsuji, N.; Uchiyama, Y.; Van Eldik, C.; Van Soelen, B.; Vecchi, M.; Veh, J.; Venter, C.; Vink, J.; Wach, T.; Wagner, S. J.; White, R.; Wiercholska, A.; Wong, Y. W.; Zacharias, M.; Zargaryan, D.; Zdziarski, A. A.; Zech, A.; Zouari, S.; Zywuca, N. "Constraining the cosmic-ray pressure in the inner Virgo Cluster using H.E.S.S. observations of M 87," *Astronomy and Astrophysics*, 675, A138, 2023.
- Hagimoto, M.; Bakx, T. J. L. C.; Serjeant, S.; Bendo, G. J.; Urquhart, S. A.; Eales, S.; Harrington, K. C.; Tamura, Y.; Umehata, H.; Berta, S.; Cooray, A. R.; Cox, P.; De Zotti, G.; Lehnert, M. D.; Riechers, D. A.; Scott, D.; Terzi, P.; Van Der Werf, P. P.; Yang, C.; Amvrosiadis, A.; Andreani, P. M.; Baker, A. J.; Beelen, A.; Borsato, E.; Buat, V.; Butler, K. M.; Dannerbauer, H.; Dunne, L.; Dye, S.; Enia, A. F. M.; Fan, L.; Gavazzi, R.; González-Nuevo, J.; Harris, A. I.; Herrera, C. N.; Hughes, D. H.; Ismail, D.; Ivison, R. J.; Jones, B.; Kohno, K.; Krips, M.; Lagache, G.; Marchetti, L.; Massardi, M.; Messias, H.; Negrello, M.; Neri, R.; Omont, A.; Perez-Fournon, I.; Sedgwick, C.; Smith, M. W. L.; Stanley, F.; Verma, A.; Vlahakis, C.; Ward, B.; Weiner, C.; Weiß, A.; Young, A. J. "Bright extragalactic ALMA redshift survey (BEARS) III: Detailed study of emission lines from 71 Herschel targets," *Monthly Notices of the Royal Astronomical Society*, 521, 5508, 2023.
- Hale, C. L.; Whittam, I. H.; Jarvis, M. J.; Best, P. N.; Thomas, N. L.; Heywood, I.; Prescott, M.; Adams, N.; Afonso, J.; An, Fangxia; Bowler, R. A. A.; Collier, J. D.; Cook, R. H. W.; Davé, R.; Frank, B. S.; Glowacki, M.; Hatfield, P. W.; Kolwa, S.; Lovell, C. C.; Maddox, N.; Marchetti, L.; Morabito, L. K.; Murphy, E.; Prandoni, I.; Randriamanakoto, Z.; Taylor, A. R. "MIGHTEE: deep 1.4 GHz source counts and the sky temperature contribution of star forming galaxies and active galactic nuclei," *Monthly Notices of the Royal Astronomical Society*, 520, 2668-2691, 2023.
- Hamanowicz, Aleksandra; Zwaan, Martin A.; Péroux, Céline; Lagos, Claudia Del P.; Klitsch, Anne; Ivison, Rob J.; Biggs, Andrew D.; Szakacs, Roland; Fresco, Alejandra "ALMACAL VIII: a pilot survey for untargeted extragalactic CO emission lines in deep ALMA calibration data," *Monthly Notices of the Royal Astronomical Society*, 519, 34, 2023.
- Hambardzumyan, L. A.; Arshakian, T. G.; Pushkarev, A. B. "BL Lacertae: a study of quasi-stationary feature trajectories in the inner part of a relativistic jet," *Communications of the Byurakan Astrophysical Observatory*, 70, 94, 2023.
- Hambardzumyan, L. A.; Arshakian, T. G.; Pushkarev, A. B. "BL Lacertae:

## APPENDIX A: PUBLICATIONS

- Recovering intrinsic trajectory of a quasi-stationary jet feature on subparsec-scales," *Communications of the Byurakan Astrophysical Observatory*, 70, 328, 2023.
- Hamed, M.; Malek, K.; Buat, V.; Junais; Ciesla, L.; Donevski, D.; Riccio, G.; Figueira, M. "The slippery slope of dust attenuation curves. Correlation of dust attenuation laws with star-to-dust compactness up to  $z = 4$ ," *Astronomy and Astrophysics*, 674, A99, 2023.
- Han, Ilseung; Kwon, Woojin; Aso, Yusuke; Bae, Jaehan; Sheehan, Patrick "Grain Growth and Dust Segregation Revealed by Multiwavelength Analysis of the Class I Protostellar Disk WL 17," *The Astrophysical Journal*, 956, 9, 2023.
- Harada, Naoto; Tokuda, Kazuki; Yamasaki, Hayao; Sato, Asako; Omura, Mitsuki; Hirano, Shingo; Onishi, Toshikazu; Tachihara, Kengo; Machida, Masahiro N. "Crescent-shaped Molecular Outflow from the Intermediate-mass Protostar DK Cha Revealed by ALMA," *The Astrophysical Journal*, 945, 63, 2023.
- Harris, C. E.; Sarbadhicary, Sumit K.; Chomiuk, L.; Piro, Anthony L.; Sand, D. J.; Valenti, S. "Radio Observations of Six Young Type Ia Supernovae," *The Astrophysical Journal*, 952, 24, 2023.
- Harsono, D.; Bjerkele, P.; Ramsey, J. P.; Pontoppidan, K. M.; Kristensen, L. E.; Jørgensen, J. K.; Calcutt, H.; Li, Z.-Y.; Plunkett, A. "JWST Peers into the Class I Protostar TMC1A: Atomic Jet and Spatially Resolved Dissociative Shock Region," *The Astrophysical Journal*, 951, L32, 2023.
- Harvey, Thomas; Maksym, W. Peter; Keel, William; Koss, Michael; Bennert, Vardha N.; Chojnowski, S. Drew; Treister, Ezequiel; Finlez, Carolina; Lintott, Chris J.; Moiseev, Alexei; Simmons, Brooke D.; Sartori, Lia F.; Urry, Megan "Signatures of feedback in the spectacular extended emission region of NGC 5972," *Monthly Notices of the Royal Astronomical Society*, 526, 4174, 2023.
- Hashiguchi, Aoi; Toba, Yoshiaki; Ota, Naomi; Oguri, Masamune; Okabe, Nobuhiro; Ueda, Yoshihiro; Imanishi, Masatoshi; Yamada, Satoshi; Goto, Tomotsugu; Koyama, Shuhei; Lee, Kianhong; Mitsuishi, Ikuyuki; Nagao, Tohru; Nishizawa, Atsushi J.; Noboriguchi, Akatoki; Oogi, Taira; Sakuta, Koki; Schramm, Malte; Shibata, Mio; Terashima, Yuichi; Yamashita, Takuji; Yanagawa, Anri; Yoshimoto, Anje "AGN number fraction in galaxy groups and clusters at  $z < 1.4$  from the Subaru Hyper Suprime-Cam survey," *Publications of the Astronomical Society of Japan*, 75, 1246, 2023.
- Hashimoto, Jun; Liu, Haiyu Baobab; Dong, Ruobing; Liu, Beibei; Muto, Takayuki; Terada, Yuka "Centimeter-sized Grains in the Compact Dust Ring around Very-low-mass Star CIDA 1," *The Astronomical Journal*, 166, 186, 2023.
- Hashimoto, T.; Álvarez-Márquez, J.; Fudamoto, Y.; Colina, L.; Inoue, A. K.; Nakazato, Y.; Ceiverino, D.; Yoshida, N.; Costantin, L.; Sugahara, Y.; Gómez, A. Crespo; Blanco-Prieto, C.; Mawatari, K.; Arribas, S.; Marques-Chaves, R.; Pereira-Santaella, M.; Bakx, T. J. L. C.; Hagimoto, M.; Hashigaya, T.; Matsuo, H.; Tamura, Y.; Usui, M.; Ren, Y. W. "Reionization and the ISM/Stellar Origins with JWST and ALMA (RIOJA): The Core of the Highest-redshift Galaxy Overdensity at  $z = 7.88$  Confirmed by NIRSPEC/JWST," *The Astrophysical Journal*, 955, L2, 2023.
- Hashimoto, Takuya; Inoue, Akio K.; Sugahara, Yuma; Fudamoto, Yoshinobu; Fujimoto, Seiji; Knudsen, K. K.; Matsuo, Hiroshi; Tamura, Yoichi; Yamanaka, Satoshi; Harikane, Yuichi; Kuno, Nario; Ono, Yoshiaki; Salak, Dragan; Ishii, Nozomi "Big Three Dragons: Molecular Gas in a Bright Lyman-break Galaxy at  $z = 7.15$ ," *The Astrophysical Journal*, 952, 48, 2023.
- Hassani, Hamid; Rosolowsky, Erik; Leroy, Adam K.; Boquien, Médéric; Lee, Janice C.; Barnes, Ashley T.; Belfiore, Francesco; Bigiel, F.; Cao, Yixian; Chevance, Mélanie; Dale, Daniel A.; Egorov, Oleg V.; Emsellem, Eric; Faesi, Christopher M.; Grasha, Kathryn; Kim, Jaeyeon; Klessen, Ralf S.; Kreckel, Kathryn; Kruijssen, J. M. Diederik; Larson, Kirsten L.; Meidt, Sharon E.; Sandstrom, Karin M.; Schinnerer, Eva; Thilker, David A.; Watkins, Elizabeth J.; Whitmore, Bradley C.; Williams, Thomas G. "PHANGS-JWST First Results: The 21  $\mu\text{m}$  Compact Source Population," *The Astrophysical Journal*, 944, L21, 2023.
- Heesen, V.; De Gasperin, F.; Schulz, S.; Basu, A.; Beck, R.; Brügger, M.; Dettmar, R.-J.; Stein, M.; Gajović, L.; Tabatabaei, F. S.; Reichherzer, P. "Diffusion of cosmic-ray electrons in M 51 observed with LOFAR at 54 MHz," *Astronomy and Astrophysics*, 672, A21, 2023.
- Heesen, V.; Klocke, T.-L.; Brügger, M.; Tabatabaei, F. S.; Basu, A.; Beck, R.; Drabent, A.; Nikiel-Wroczyński, B.; Paladino, R.; Schulz, S.; Stein, M. "Nearby galaxies in the LOFAR Two-metre Sky Survey. II. The magnetic field-gas relation," *Astronomy and Astrophysics*, 669, A8, 2023.
- Heintz, K. E.; Giménez-Arteaga, C.; Fujimoto, S.; Brammer, G.; Espada, D.; Gillman, S.; González-López, J.; Greve, T. R.; Harikane, Y.; Hatsukade, B.; Knudsen, K. K.; Koekemoer, A. M.; Kohno, K.; Kokorev, V.; Lee, M. M.; Magdis, G. E.; Nelson, E. J.; Rizzo, F.; Sanders, R. L.; Schaefer, D.; Shapley, A. E.; Strait, V. B.; Toft, S.; Valentino, F.; Van Der Wel, A.; Vijayan, A. P.; Watson, D.; Bauer, F. E.; Christiansen, C. R.; Wilson, S. N. "The Gas and Stellar Content of a Metal-poor Galaxy at  $z = 8.496$  as Revealed by JWST and ALMA," *The Astrophysical Journal*, 944, L30, 2023.
- Hera Collaboration; Abdurashidova, Zara; Adams, Tyrone; Aguirre, James E.; Alexander, Paul; Ali, Zaki S.; Baartman, Rushelle; Balfour, Yanga; Barkana, Rennan; Beardsley, Adam P.; Bernardi, Gianni; Billings, Tashalee S.; Bowman, Judd D.; Bradley, Richard F.; Breitman, Daniela; Bull, Philip; Burba, Jacob; Carey, Steve; Carilli, Chris L.; Cheng, Carina; Choudhuri, Samir; Deboer, David R.; De Lera Acedo, Eloy; Dexter, Matt; Dillon, Joshua S.; Ely, John; Ewall-Wice, Aaron; Fagnoni, Nicolas; Fialkov, Anastasia; Fritz, Randall; Furlanetto, Steven R.; Gale-Sides, Kingsley; Garsden, Hugh; Glendenning, Brian; Gorce, Adélie; Gorthi, Deepthi; Greig, Bradley; Grobbelaar, Jasper; Haldaj, Ziyaad; Hazelton, Bryna J.; Heimersheim, Stefan; Hewitt, Jacqueline N.; Hickish, Jack; Jacobs, Daniel C.; Julius, Austin; Kern, Nicholas S.; Kerrigan, Joshua; Kittiwisit, Piyanat; Kohn, Saul A.; Kolopanis, Matthew; Lanman, Adam; La Plante, Paul; Lewis, David; Liu, Adrian; Loots, Anita; Ma, Yin-Zhe; Macmahon, David H. E.; Malan, Laurence; Malgas, Keith; Malgas, Cresshim; Maree, Matthys; Marero, Bradley; Martinot, Zachary E.; McBride, Lisa; Mesinger, Andrei; Mirocha, Jordan; Molewa, Mathakane; Morales, Miguel F.; Mosiane, Tshogefalang; Muñoz, Julian B.; Murray, Steven G.; Naggal, Vighnesh; Neben, Abraham R.; Nikolic, Bojan; Nunhokee, Chuneeta D.; Nuwegeld, Hans; Parsons, Aaron R.; Pascua, Robert; Patra, Nipanjana; Pieterse, Samantha; Qin, Yuxiang; Razavi-Ghods, Nima; Robnett, James; Rosie, Kathryn; Santos, Mario G.; Sims, Peter; Singh, Saurabh; Smith, Craig; Swarts, Hilton; Tan, Jianrong; Thyagarajan, Nithyanandan; Wilensky, Michael J.; Williams, Peter K. G.; Van Wyngaarden, Pieter; Zheng, Haoxuan "Improved Constraints on the 21 cm EoR Power Spectrum and the X-Ray Heating of the IGM with HERA Phase I Observations," *The Astrophysical Journal*, 945, 124, 2023.
- Herenz, E. C.; Inoue, J.; Salas, H.; Koenigs, B.; Moya-Sierralta, C.; Cannon, J. M.; Hayes, M.; Papaderos, P.; Östlin, G.; Bik, A.; Le Reste, A.; Kusakabe, H.; Monreal-Ibero, A.; Puschig, J. "A  $\sim 15$  kpc outflow cone piercing through the halo of the blue compact metal-poor galaxy SBS 0335-052E," *Astronomy and Astrophysics*, 670, A152, 2023.
- Hernández-García, L.; Panessa, F.; Bruni, G.; Bassani, L.; Arévalo, P.; Patiño-Alvarez, V. M.; Tramacere, A.; Lira, P.; Sánchez-Sáez, P.; Bauer, F. E.; Chavushyan, V.; Carraro, R.; Förster, F.; Arancibia, A. M. Muñoz; Ubertini, P. "Multiwavelength monitoring of the nucleus in PBC J2333.9-2343: the giant radio galaxy with a blazar-like core," *Monthly Notices of the Royal Astronomical Society*, 525, 2187, 2023.
- Hernández-Vera, C.; Guzmán, V. V.; Goicoechea, J. R.; Maillard, V.; Pety, J.; Le Petit, F.; Gerin, M.; Bron, E.; Roueff, E.; Abergel, A.; Schirmer, T.; Carpenter, J.; Gratier, P.; Gordon, K.; Misselt, K. "The extremely sharp transition between molecular and ionized gas in the Horsehead nebula," *Astronomy and Astrophysics*, 677, A152, 2023.
- Herranz, D.; López-Cañiego, M.; López-Caraballo, C. H.; Génova-Santos, R. T.; Perrott, Y. C.; Rubiño-Martín, J. A.; Rebolo, R.; Artal, E.; Ashdown, M.; Barreiro, R. B.; Casas, F. J.; De La Hoz, E.; Fernández-Torreiro, M.; Guidi, F.; Hoyland, R. J.; Lasenby, A. N.; Martínez-González, E.; Peel, M. W.; Piccirillo, L.; Poidevin, F.; Ruiz-Granados, B.; Tramonte, D.;

- Vansyngel, F.; Vielva, P.; Watson, R. A. "QUIJOTE scientific results - IX. Radio sources in the QUIJOTE-MFI wide survey maps," *Monthly Notices of the Royal Astronomical Society*, 519, 3526, 2023.
- Ho, Anna Y. Q.; Perley, Daniel A.; Chen, Ping; Schulze, Steve; Dhillon, Vik; Kumar, Harsh; Suresh, Aswin; Swain, Vishwajeet; Bremer, Michael; Smartt, Stephen J.; Anderson, Joseph P.; Anupama, G. C.; Awiphan, Supachai; Barway, Sudhanshu; Bellm, Eric C.; Ben-Ami, Sagi; Bhalerao, Varun; De Boer, Thomas; Brink, Thomas G.; Burruss, Rick; Chandra, Poonam; Chen, Ting-Wan; Chen, Wen-Ping; Cooke, Jeff; Coughlin, Michael W.; Das, Kaustav K.; Drake, Andrew J.; Filippenko, Alexei V.; Freeburn, James; Fremling, Christopher; Fulton, Michael D.; Gal-Yam, Avishay; Galbany, Lluís; Gao, Hua; Graham, Matthew J.; Gromadzki, Mariusz; Gutiérrez, Claudia P.; Hinds, K. -Ryan; Inserra, Cosimo; A J, Nayana; Karambelkar, Viraj; Kasliwal, Mansi M.; Kulkarni, Shri; Müller-Bravo, Tomás E.; Magnier, Eugene A.; Mahabal, Ashish A.; Moore, Thomas; Ngeow, Chow-Choong; Nicholl, Matt; Ofek, Eran O.; Omand, Conor M. B.; Onori, Francesca; Pan, Yen-Chen; Pessi, Priscila J.; Petitpas, Glen; Polishook, David; Poshyachinda, Saran; Pursiainen, Miika; Riddle, Reed; Rodríguez, Antonio C.; Rusholme, Ben; Segre, Enrico; Sharma, Yashvi; Smith, Ken W.; Sollerman, Jesper; Srivastav, Shubham; Strotjohann, Nora Linn; Suhr, Mark; Svinkin, Dmitry; Wang, Yanan; Wiseman, Philip; Wold, Avery; Yang, Sheng; Yang, Yi; Yao, Yuhang; Young, David R.; Zheng, Weikang "Minutes-duration optical flares with supernova luminosities," *Nature*, 623, 927, 2023.
- Ho, Anna Y. Q.; Perley, Daniel A.; Gal-Yam, Avishay; Lunnan, Ragnhild; Sollerman, Jesper; Schulze, Steve; Das, Kaustav K.; Dobie, Douglas; Yao, Yuhang; Fremling, Christopher; Adams, Scott; Anand, Shreya; Andreoni, Igor; Bellm, Eric C.; Bruch, Rachel J.; Burdge, Kevin B.; Castro-Tirado, Alberto J.; Dahiwal, Aishwarya; De, Kishalay; Dekany, Richard; Drake, Andrew J.; Duev, Dmitry A.; Graham, Matthew J.; Helou, George; Kaplan, David L.; Karambelkar, Viraj; Kasliwal, Mansi M.; Kool, Erik C.; Kulkarni, S. R.; Mahabal, Ashish A.; Medford, Michael S.; Miller, A. A.; Nordin, Jakob; Ofek, Eran; Petitpas, Glen; Riddle, Reed; Sharma, Yashvi; Smith, Roger; Stewart, Adam J.; Taggart, Kirsty; Tartaglia, Leonardo; Tzanidakis, Anastasios; Winters, Jan Martin "A Search for Extragalactic Fast Blue Optical Transients in ZTF and the Rate of AT2018cow-like Transients," *The Astrophysical Journal*, 949, 120, 2023.
- Hosseinzadeh, Griffin; Sand, David J.; Sarbadhicary, Sumit K.; Ryder, Stuart D.; Jha, Saurabh W.; Dong, Yize; Bostroem, K. Azalee; Andrews, Jennifer E.; Hoang, Emily; Janzen, Daryl; Jencson, Jacob E.; Lundquist, Michael; Meza Retamal, Nicolas E.; Pearson, Jeniveve; Shrestha, Manisha; Valenti, Stefano; Wyatt, Samuel; Farah, Joseph; Howell, D. Andrew; McCully, Curtis; Newsome, Megan; Padilla Gonzalez, Estefania; Pellegrino, Craig; Terreran, Giacomo; Alzaabi, Muzoun; Green, Elizabeth M.; Gurney, Jessica L.; Milne, Peter A.; Ridenhour, Kaycee I.; Smith, Nathan; Robles, Paulina Soto; Kwok, Lindsey A.; Schwab, Michaela; Gromadzki, Mariusz; Buckley, David A. H.; Itagaki, Koichi; Hiramatsu, Daichi; Chomiuk, Laura; Lundqvist, Peter; Haislip, Joshua; Kouprianov, Vladimir; Reichart, Daniel E. "The Early Light Curve of SN 2023bee: Constraining Type Ia Supernova Progenitors the Apian Way," *The Astrophysical Journal*, 953, L15, 2023.
- Hou, Kuan-Chou; Hallinan, Gregg; Keshet, Uri "Synchrotron emission from virial shocks around stacked OVRO-LWA galaxy clusters," *Monthly Notices of the Royal Astronomical Society*, 521, 5786, 2023.
- Hsieh, Cheng-Han; Arce, Héctor G.; Li, Zhi-Yun; Dunham, Michael; Offner, Stella; Stephens, Ian W.; Stutz, Amelia; Megeath, Tom; Kong, Shuo; Plunkett, Adele; Tobin, John J.; Zhang, Yichen; Mardones, Diego; Pineda, Jaime E.; Stanke, Thomas; Carpenter, John "The Evolution of Protostellar Outflow Cavities, Kinematics, and Angular Distribution of Momentum and Energy in Orion A: Evidence for Dynamical Cores," *The Astrophysical Journal*, 947, 25, 2023.
- Hsieh, T.-H.; Segura-Cox, D. M.; Pineda, J. E.; Caselli, P.; Bouscasse, L.; Neri, R.; Lopez-Sepulcre, A.; Valdivia-Mena, M. T.; Moreira, M. J.; Henning, Th.; Smirnov-Pinchukov, G. V.; Semenov, D.; Möller, Th.; Cunningham, N.; Fuente, A.; Marino, S.; Dutrey, A.; Tafalla, M.; Chapillon, E.; Ceccarelli, C.; Zhao, B. "PRODIGE - envelope to disk with NOEMA. II. Small-scale temperature structure and streamer feeding the SVS13A protobinary based on CH<sub>3</sub>CN and DCN," *Astronomy and Astrophysics*, 669, A137, 2023.
- Hsu, Po-Chih; Koay, Jun Yi; Matsushita, Satoki; Hwang, Chong-Yuan; Hovatta, Talvikki; Kiehlmann, Sebastian; Readhead, Anthony; Max-Moerbeck, Walter; Reeves, Rodrigo "Milliarcsecond core size dependence of the radio variability of blazars," *Monthly Notices of the Royal Astronomical Society*, 525, 5105, 2023.
- Hsu, Shih-Ying; Liu, Sheng-Yuan; Johnstone, Doug; Liu, Tie; Bronfman, Leonardo; Chen, Huei-Ru Vivien; Dutta, Somnath; Eden, David J.; Evans, Neal J.; Ii, Hirano, Naomi; Juvela, Mika; Kuan, Yi-Jehng; Kwon, Woojin; Lee, Chin-Fei; Lee, Chang Won; Lee, Jeong-Eun; Li, Shanghuo; Liu, Chun-Fan; Liu, Xunchuan; Luo, Qiuyi; Qin, Sheng-Li; Rawlings, Mark G.; Sahu, Dipen; Sanhueza, Patricio; Shang, Hsien; Tatematsu, Ken'ichi; Yang, Yao-Lun "ALMA Survey of Orion Planck Galactic Cold Clumps (ALMASOP): The Warm-envelope Origin of Hot Corinos," *The Astrophysical Journal*, 956, 120, 2023.
- Hsu, Tzu-Yin; Hashimoto, Tetsuya; Hatsukade, Bunyo; Goto, Tomotsugu; Wang, Po-Ya; Ling, Chih-Teng; Ho, Simon C.-C.; Uno, Yuri "The molecular gas kinematics in the host galaxy of non-repeating FRB 180924B," *Monthly Notices of the Royal Astronomical Society*, 519, 2030, 2023.
- Hu, Chen-Ran; Huang, Yong-Feng "A Comprehensive Analysis of Repeating Fast Radio Bursts," *The Astrophysical Journal Supplement Series*, 269, 17, 2023.
- Hu, Yue; Lazarian, A. "Characterizing three-dimensional magnetic field, turbulence, and self-gravity in the star-forming region L1688," *Monthly Notices of the Royal Astronomical Society*, 524, 4431, 2023.
- Huang, K.-Y.; Viti, S.; Holdship, J.; Mangum, J. G.; Martín, S.; Harada, N.; Muller, S.; Sakamoto, K.; Tanaka, K.; Yoshimura, Y.; Herrero-Illana, R.; Meier, D. S.; Behrens, E.; Van Der Werf, P. P.; Henkel, C.; García-Burillo, S.; Rivilla, V. M.; Emig, K. L.; Colzi, L.; Humire, P. K.; Aladro, R.; Bouvier, M. "Reconstructing the shock history in the CMZ of NGC 253 with ALCHEMI," *Astronomy and Astrophysics*, 675, A151, 2023.
- Huang, Long; Wang, Hui; Gao, Zhifu; Zeng, Xiangyun; Chang, Zhangyong "A measure of cosmological distance using the C IV Baldwin effect in quasars," *Astronomy and Astrophysics*, 674, A163, 2023.
- Huang, Shuo; Kawabe, Ryohei; Kohno, Kotaro; Saito, Toshiaki; Mizukoshi, Shoichiro; Iono, Daisuke; Michiyama, Tomonari; Tamura, Yoichi; Hayward, Christopher C.; Umehata, Hideki "J0107a: A Barred Spiral Dusty Star-forming Galaxy at  $z = 2.467$ ," *The Astrophysical Journal*, 958, L26, 2023.
- Hughes, A. K.; Sivakoff, G. R.; Macpherson, C. E.; Miller-Jones, J. C. A.; Tetarenko, A. J.; Altamirano, D.; Anderson, G. E.; Belloni, T. M.; Heinz, S.; Jonker, P. G.; Körding, E. G.; Maitra, D.; Markoff, S. B.; Migliari, S.; Mooley, K. P.; Rupen, M. P.; Russell, D. M.; Russell, T. D.; Sarazin, C. L.; Soria, R.; Tudose, V. "Short Timescale Evolution of the Polarized Radio Jet during V404 Cygni's 2015 Outburst," *Monthly Notices of the Royal Astronomical Society*, 521, 185, 2023.
- Hugo, B.; Bernardi, G.; Smirnov, O. M.; Dallacasa, D.; Venturi, T.; Murgia, M.; Pizzo, R. F. "Radio multifrequency observations of Abell 781 with the WSRT," *Monthly Notices of the Royal Astronomical Society*, 526, 5278, 2023.
- Hunt, L. K.; Belfiore, F.; Lelli, F.; Draine, B. T.; Marasco, A.; García-Burillo, S.; Venturi, G.; Combes, F.; Weiß, A.; Henkel, C.; Menten, K. M.; Annibali, F.; Casasola, V.; Cignoni, M.; Mcleod, A.; Tosi, M.; Beltrán, M.; Concas, A.; Cresci, G.; Ginolfi, M.; Kumari, N.; Mannucci, F. "Gas, dust, and the CO-to-molecular gas conversion factor in low-metallicity starbursts," *Astronomy and Astrophysics*, 675, A64, 2023.
- Hunter, Laura Congreve; Van Zee, Liese; Mcquinn, Kristen B. W.; Cohen, Roger E.; Markham, Madison; Dolphin, Andrew E. "Timescale of Stellar Feedback-driven Turbulence in the ISM: A Deep Dive into UGC 4305," *The Astronomical Journal*, 166, 144, 2023.
- Hunter, Todd R.; Indebetouw, Remy; Brogan, Crystal L.; Berry, Kristin; Chang, Chin-Shin; Francke, Harold; Geers, Vincent C.; Gómez, Laura; Hibbard,

## APPENDIX A: PUBLICATIONS

- John E.; Humphreys, Elizabeth M.; Kent, Brian R.; Kepley, Amanda A.; Kunneriath, Devaky; Lipnicky, Andrew; Loomis, Ryan A.; Mason, Brian S.; Masters, Joseph S.; Maud, Luke T.; Muters, Dirk; Sabater, Jose; Sugimoto, Kanako; Szűcs, László; Vasiliev, Eugene; Videla, Liza; Villard, Eric; Williams, Stewart J.; Xue, Rui; Yoon, Ilsang "The ALMA Interferometric Pipeline Heuristics," *Publications of the Astronomical Society of the Pacific*, 135, 58, 2023.
- Hurley-Walker, N.; Rea, N.; Mcsweeney, S. J.; Meyers, B. W.; Lenc, E.; Heywood, I.; Hyman, S. D.; Men, Y. P.; Clarke, T. E.; Coti Zelati, F.; Price, D. C.; Horváth, C.; Galvin, T. J.; Anderson, G. E.; Bahramian, A.; Barr, E. D.; Bhat, N. D. R.; Caleb, M.; Dall'Orta, M.; De Martino, D.; Giacintucci, S.; Morgan, J. S.; Rajwade, K. M.; Stappers, B.; Williams, A. "A long-period radio transient active for three decades," *Nature*, 619, 487, 2023.
- Hutchens, Zackary L.; Kannappan, Sheila J.; Berlind, Andreas A.; Asad, Mehnaaz; Eckert, Kathleen D.; Stark, David V.; Carr, Derrick S.; Castellote, Ella R.; Baker, Andrew J.; Hess, Kelley M.; Moffett, Amanda J.; Norris, Mark A.; Croton, Darren "The RESOLVE and ECO Gas in Galaxy Groups Initiative: The Group Finder and the Group H I-Halo Mass Relation," *The Astrophysical Journal*, 956, 51, 2023.
- Hygate, A. P. S.; Hodge, J. A.; Da Cunha, E.; Rybak, M.; Schouws, S.; Inami, H.; Stefanon, M.; Graziani, L.; Schneider, R.; Dayal, P.; Bouwens, R. J.; Smit, R.; Bowler, R. A. A.; Endsley, R.; Gonzalez, V.; Oesch, P. A.; Stark, D. P.; Algera, H. S. B.; Aravena, M.; Barrufet, L.; Ferrara, A.; Fudamoto, Y.; Hilhorst, J. H. A.; De Looze, I.; Nanayakkara, T.; Pallottini, A.; Riechers, D. A.; Sommovigo, L.; Topping, M. W.; Van Der Werf, P. "The ALMA REBELS survey: Discovery of a massive, highly star-forming and morphologically complex ULIRG at  $z=7.31$ ," *Monthly Notices of the Royal Astronomical Society*, 524, 1775, 2023.
- Hyun, Minhee; Im, Myungshin; Smail, Ian R.; Cotton, William D.; Birkin, Jack E.; Kikuta, Satoshi; Shim, Hyunjin; Willmer, Christopher N. A.; Condon, James J.; Windhorst, Rogier A.; Cohen, Seth H.; Jansen, Rolf A.; Ly, Chun; Matsuda, Yuichi; Fazio, Giovanni G.; Swinbank, A. M.; Yan, Haojing "The JCMT SCUBA-2 Survey of the James Webb Space Telescope North Ecliptic Pole Time-Domain Field," *The Astrophysical Journal Supplement Series*, 264, 19, 2023.
- Ibrahim, A. Y.; Borghese, A.; Rea, N.; Zelati, F. Coti; Parent, E.; Russell, T. D.; Ascenzi, S.; Sathyaprakash, R.; Götz, D.; Mereghetti, S.; Topinka, M.; Rigoselli, M.; Savchenko, V.; Campana, S.; Israel, G. L.; Tiengo, A.; Perna, R.; Turolla, R.; Zane, S.; Esposito, P.; Castillo, G. A. Rodriguez; Graber, V.; Possenti, A.; Dehman, C.; Ronchi, M.; Loru, S. "Deep X-Ray and Radio Observations of the First Outburst of the Young Magnetar Swift J1818.0-1607," *The Astrophysical Journal*, 943, 20, 2023.
- Ichikawa, Kohei; Yamashita, Takuji; Merloni, Andrea; Li, Junyao; Liu, Teng; Salvato, Mara; Akiyama, Masayuki; Arcodia, Riccardo; Dwelly, Tom; Chen, Xiaoyang; Imanishi, Masatoshi; Inayoshi, Kohei; Kawaguchi, Toshihiro; Kawamuro, Taiki; Kokubo, Mitsuru; Matsuoka, Yoshiki; Nagao, Tohru; Schramm, Malte; Suh, Hyewon; Tanaka, Masayuki; Toba, Yoshiki; Ueda, Yoshihiro "eROSITA Final Equatorial-Depth Survey (eFEDS). eFEDS X-ray view of WERGS radio galaxies selected by the Subaru/HSC and VLA/FIRST survey," *Astronomy and Astrophysics*, 672, A171, 2023.
- Ighina, L.; Caccianiga, A.; Moretti, A.; Belladitta, S.; Broderick, J. W.; Drouart, G.; Leung, J. K.; Seymour, N. "New radio-loud QSOs at the end of the Re-ionization epoch," *Monthly Notices of the Royal Astronomical Society*, 519, 2060, 2023.
- Iglesias, Daniela P.; Panić, Olja; Van Den Ancker, Mario; Petr-Gotzens, Monika G.; Siess, Lionel; Vioque, Miguel; Pascucci, Ilaria; Oudmaijer, René; Miley, James "X-shooter survey of young intermediate-mass stars - I. Stellar characterization and disc evolution," *Monthly Notices of the Royal Astronomical Society*, 519, 3958, 2023.
- Ignesti, Alessandro; Brienza, Marisa; Vulcani, Benedetta; Poggianti, Bianca M.; Marasco, Antonino; Smith, Rory; Hardcastle, Martin J.; Botteon, Andrea; Roberts, Ian D.; Fritz, Jacopo; Paladino, Rosita; Gitti, Myriam; Wolter, Anna; Tomičić, Neven; Mcgee, Sean; Moretti, Alessia; Gullieuszik, Marco; Drabent, Alexander "On the Encounter between the GASP Galaxy J036 and the Radio Plume of GIN 049," *The Astrophysical Journal*, 956, 122, 2023.
- Imanishi, Masatoshi; Baba, Shunsuke; Nakanishi, Kouichiro; Izumi, Takuma "Dense Molecular Gas Properties of the Central Kiloparsec of Nearby Ultraluminous Infrared Galaxies Constrained by ALMA Three Transition-line Observations," *The Astrophysical Journal*, 950, 75, 2023.
- Imanishi, Masatoshi; Baba, Shunsuke; Nakanishi, Kouichiro; Izumi, Takuma "ALMA 0.5 kpc Resolution Spatially Resolved Investigations of Nuclear Dense Molecular Gas Properties in Nearby Ultraluminous Infrared Galaxies Based on HCN and HCO<sup>+</sup> Three Transition Line Data," *The Astrophysical Journal*, 954, 148, 2023.
- Inoue, Kaiki Taro; Minezaki, Takeo; Matsushita, Satoki; Nakanishi, Kouichiro "ALMA Measurement of 10 kpc Scale Lensing-power Spectra toward the Lensed Quasar MG J0414+0534," *The Astrophysical Journal*, 954, 197, 2023.
- Irbor, T.; Hoare, M. G.; Burton, M.; Cotton, W. D.; Diamond, P.; Dougherty, S.; Ellingsen, S. P.; Fender, R.; Fuller, G. A.; Garrington, S.; Goldsmith, P. F.; Green, J.; Gunn, A. G.; Jackson, J.; Kurtz, S.; Lumsden, S. L.; Marti, J.; McDonald, I.; Molinari, S.; Moore, T. J.; Mutale, M.; Muxlow, T.; O'Brien, T.; Oudmaijer, R. D.; Paladini, R.; Pandian, J. D.; Paredes, J. M.; Richards, A. M. S.; Sanchez-Monge, A.; Spencer, R.; Thompson, M. A.; Umana, G.; Urquhart, J. S.; Wieringa, M.; Zijlstra, A. "The Co-Ordinated radio and infrared survey for high-mass star formation - V. The CORNISH-South survey and catalogue," *Monthly Notices of the Royal Astronomical Society*, 520, 1073, 2023.
- Ismail, D.; Beelen, A.; Buat, V.; Berta, S.; Cox, P.; Stanley, F.; Young, A.; Jin, S.; Neri, R.; Bakx, T.; Dannerbauer, H.; Butler, K.; Cooray, A.; Nanni, A.; Omont, A.; Serjeant, S.; Van Der Werf, P.; Vlahakis, C.; Weiß, A.; Yang, C.; Baker, A. J.; Bendo, G.; Borsato, E.; Chartab, N.; Dye, S.; Eales, S.; Gavazzi, R.; Hughes, D.; Ivison, R.; Jones, B. M.; Krips, M.; Lehnert, M.; Marchetti, L.; Messias, H.; Negrello, M.; Perez-Fourmon, I.; Riechers, D. A.; Urquhart, S. "z-GAL: A NOEMA spectroscopic redshift survey of bright Herschel galaxies. II. Dust properties," *Astronomy and Astrophysics*, 678, A27, 2023.
- Isobe, Naoki; Nagai, Hiroshi; Kino, Motoki; Baba, Shunsuke; Nakagawa, Takao; Sunada, Yuji; Tashiro, Makoto "ALMA ACA Detection of Submillimeter Emission Associated with the Western Hot Spot of the Radio Galaxy Pictor A," *The Astrophysical Journal*, 953, 76, 2023.
- Iwata, Yuhei; Oka, Tomoharu; Takekawa, Shunya; Tsujimoto, Shiho; Enokiya, Rei "ALMA View of the High-velocity-dispersion Compact Cloud CO 0.02-0.02 at the Galactic Center," *The Astrophysical Journal*, 950, 25, 2023.
- Izquierdo, A. F.; Testi, L.; Facchini, S.; Rosotti, G. P.; Van Dishoeck, E. F.; Wölfer, L.; Panque-Carreño, T. "The Disc Miner. II. Revealing gas substructures and kinematic signatures from planet-disc interaction through line profile analysis," *Astronomy and Astrophysics*, 674, A113, 2023.
- Izumi, Takuma; Wada, Keiichi; Imanishi, Masatoshi; Nakanishi, Kouichiro; Kohno, Kotaro; Kudoh, Yuki; Kawamuro, Taiki; Baba, Shunsuke; Matsumoto, Naoki; Fujita, Yutaka; Tristram, Konrad R. W. "Supermassive black hole feeding and feedback observed on subparsec scales," *Science*, 382, 554, 2023.
- Jahns, J. N.; Spitler, L. G.; Nimmo, K.; Hewitt, D. M.; Snelders, M. P.; Seymour, A.; Hessel, J. W. T.; Gourdji, K.; Michilli, D.; Hilmarsson, G. H. "The FRB 20121102A November rain in 2018 observed with the Arecibo Telescope," *Monthly Notices of the Royal Astronomical Society*, 519, 666, 2023.
- Jaraba, Santiago; García-Bellido, Juan; Kuroyanagi, Sachiko; Ferraiuolo, Sarah; Braglia, Matteo "Stochastic gravitational wave background constraints from Gaia DR3 astrometry," *Monthly Notices of the Royal Astronomical Society*, 524, 3609, 2023.
- Jarvis, Matt J.; Heywood, Ian; Jewell, Sophie M.; Deane, Roger P.; Klöckner, H.-R.; Ponomareva, Anastasia A.; Maddox, Natasha; Baker, Andrew J.; Bianchetti, Alessandro; Hess, Kelley M.; Roberts, Hayley; Rodighiero, Giulia; Ruffa, Ilaria; Sinigaglia, Francesco; Varadaraj, R.

- G.; Whittam, I. H.; Adams, Elizabeth A. K.; Baes, Maarten; Murphy, Eric J.; Pan, Hengxing; Vaccari, Mattia "The discovery of a  $z = 0.7092$  OH megamaser with the MIGHTEE survey," *Monthly Notices of the Royal Astronomical Society*, 2312, , 2023.
- Javaherian, Mohsen; Miraghaei, Halime; Moradpour, Hooman "Morphological-based Analyses for Parameterizing Symmetry in Radio Galaxies," *The Astronomical Journal*, 166, 124, 2023.
- Jeong, Hyeon-Woo; Lee, Sang-Sung; Cheong, Whee Yeon; Kim, Jae-Young; Lee, Jee Won; Kang, Sincheol; Kim, Sang-Hyun; Rani, B.; Park, Jongho; Gurwell, Mark A. "Double SSA spectrum and magnetic field strength of the FSRQ 3C 454.3," *Monthly Notices of the Royal Astronomical Society*, 523, 5703, 2023.
- Jiang, Wu; Shen, Zhiqiang; Martí-Vidal, Ivan; Yan, Zhen; Huang, Lei; Gold, Roman; Li, Ya-Ping; Xie, Fuguo; Kawaguchi, Noriyuki "Observational Evidence of a Centi-parsec Supermassive Black Hole Binary Existing in the Nearby Galaxy M81," *The Astrophysical Journal*, 959, 11, 2023.
- Jiao, Wenyu; Wang, Ke; Pillai, Thushara G. S.; Baug, Tapas; Zhang, Siju; Xu, Fengwei "Fragmentation of the High-mass "Starless" Core G10.21-0.31: A Coherent Evolutionary Picture for Star Formation," *The Astrophysical Journal*, 945, 81, 2023.
- Jiménez-Andrade, E. F.; Cantalupo, S.; Magnelli, B.; Romano-Díaz, E.; Gómez-Guijarro, C.; Mackenzie, R.; Smolčić, V.; Murphy, E.; Matthee, J.; Toft, S. "The Ly  $\alpha$ , C IV, and He II nebulae around J1000+0234: a galaxy pair at the center of a galaxy overdensity at  $z = 4.5$ ," *Monthly Notices of the Royal Astronomical Society*, 521, 2326, 2023.
- Jiménez-Donaire, María J.; Brown, Toby; Wilson, Christine D.; Roberts, Ian D.; Zabel, Nikki; Ellison, Sara L.; Thorp, Mallory; Villanueva, Vicente; Chown, Ryan; Bisaria, Dhruv; Bolatto, Alberto D.; Boselli, Alessandro; Catinella, Barbara; Chung, Aeree; Cortese, Luca; Davis, Timothy A.; Lagos, Claudia D. P.; Lee, Bumhyun; Parker, Laura C.; Spekkens, Kristine; Stevens, Adam R. H.; Sun, Jiayi "VERTICO. III. The Kennicutt-Schmidt relation in Virgo cluster galaxies," *Astronomy and Astrophysics*, 671, A3, 2023.
- Jin, Ruolan; Ng, C.-Y.; Roberts, Mallory S. E.; Li, Kwan-Lok "High-resolution Radio Study of the Dragonfly Pulsar Wind Nebula Powered by PSR J2021+3651," *The Astrophysical Journal*, 942, 100, 2023.
- Jin, Shoko; Trager, Scott C.; Dalton, Gavin B.; Aguerri, J. Alfonso L.; Drew, J. E.; Falcón-Barroso, Jesús; Gänsicke, Boris T.; Hill, Vanessa; Iovino, Angela; Pieri, Matthew M.; Poggianti, Bianca M.; Smith, D. J. B.; Vallenari, Antonella; Abrams, Don Carlos; Aguado, David S.; Antoja, Teresa; Aragón-Salamanca, Alfonso; Ascasibar, Yago; Babusiaux, Carine; Balcells, Marc; Barrena, R.; Battaglia, Giuseppina; Belokurov, Vasily; Bensby, Thomas; Bonifacio, Piercarlo; Bragaglia, Angela; Carrasco, Esperanza; Carrera, Ricardo; Cornwell, Daniel J.; Domínguez-Palmero, Lilian; Duncan, Kenneth J.; Famaey, Benoit; Fariña, Cecilia; Gonzalez, Oscar A.; Guest, Steve; Hatch, Nina A.; Hess, Kelley M.; Hoskin, Matthew J.; Irwin, Mike; Knapen, Johan H.; Koposov, Sergey E.; Kuchner, Ulrike; Laigle, Clotilde; Lewis, Jim; Longhetti, Marcella; Lucatello, Sara; Méndez-Abreu, Jairo; Mercurio, Amata; Molaeinezhad, Alireza; Monguió, María; Morrison, Sean; Murphy, David N. A.; Peralta De Arriba, Luis; Pérez, Isabel; Pérez-Ràfols, Ignasi; Picó, Sergio; Raddi, Roberto; Romero-Gómez, Mercè; Royer, Frédéric; Siebert, Arnaud; Seabroke, George M.; Som, Debopam; Terrett, David; Thomas, Guillaume; Wesson, Roger; Worley, C. Clare; Alfaro, Emilio J.; Prieto, Carlos Allende; Alonso-Santiago, Javier; Amos, Nicholas J.; Ashley, Richard P.; Balaguer-Núñez, Lola; Balbinot, Eduardo; Bellazzini, Michele; Benn, Chris R.; Berlanas, Sara R.; Bernard, Edouard J.; Best, Philip; Bettoni, Daniela; Bianco, Andrea; Bishop, Georgia; Blomqvist, Michael; Boeche, Corrado; Bolzonella, Micol; Bonoli, Silvia; Bosma, Albert; Britavskiy, Nikolay; Busarello, Gianni; Caffau, Elisabetta; Cantat-Gaudin, Tristan; Castro-Ginard, Alfred; Couto, Guilherme; Carbajo-Hijarrubia, Juan; Carter, David; Casamiquela, Laia; Conrado, Ana M.; Corcho-Caballero, Pablo; Costantin, Luca; Deason, Alis; De Burgos, Abel; De Grandi, Sabrina; Di Matteo, Paola; Domínguez-Gómez, Jesús; Dorda, Ricardo; Drake, Alyssa; Dutta, Rajeshwari; Erkal, Denis; Feltzing, Sofia; Ferré-Mateu, Anna; Feuillet, Diane; Figueras, Francesca; Fossati, Matteo; Franciosini, Elena; Frasca, Antonio; Fumagalli, Michele; Gallazzi, Anna; García-Benito, Rubén; Fusillo, Nicola Gentile; Gebran, Marwan; Gilbert, James; Gledhill, T. M.; González Delgado, Rosa M.; Greimel, Robert; Guarcello, Mario Giuseppe; Guerra, Jose; Gullieuszk, Marco; Haines, Christopher P.; Hardcastle, Martin J.; Harris, Amy; Haywood, Misha; Helmi, Amina; Hernandez, Nauzet; Herrero, Artemio; Hughes, Sarah; Irsic, Vid; Jablonka, Pascale; Jarvis, Matt J.; Jordi, Carme; Kondapally, Rohit; Kordopatis, Georges; Krogager, Jens-Kristian; La Barbera, Francesco; Lam, Man I.; Larsen, Søren S.; Lemasle, Bertrand; Lewis, Ian J.; Lhomé, Emilie; Lind, Karin; Lodi, Marcello; Longobardi, Alessia; Lonoce, Ilaria; Magrini, Laura; Maíz Apellániz, Jesús; Marchal, Olivier; Marco, Amparo; Martin, Nicolas F.; Matsuno, Tadamuni; Maurogordato, Sophie; Merluzzi, Paola; Miralda-Escudé, Jordi; Molinari, Emilio; Monari, Giacomo; Morelli, Lorenzo; Mottram, Christopher J.; Naylor, Tim; Negueruela, Ignacio; Onorbe, Jose; Pancino, Elena; Peirani, Sébastien; Peletier, Reynier F.; Pozzetti, Lucia; Rainer, Monica; Ramos, Pau; Read, Shaun C.; Rossi, Elena Maria; Röttgering, Huub J. A.; Rubiño-Martín, Jose Alberto; Sabater Montes, Jose; San Juan, José; Sanna, Nicoletta; Schallig, Ellen; Schiavon, Ricardo P.; Schultheis, Mathias; Serra, Paolo; Shimwell, Timothy W.; Simón-Díaz, Sergio; Smith, Russell J.; Sordo, Rosanna; Sorini, Daniele; Soubiran, Caroline; Starkenburg, Else; Steele, Iain A.; Stott, John; Stuijk, Remko; Tolstoy, Eline; Tortora, Crescenzo; Tsantaki, Maria; Van Der Swaelmen, Mathieu; Van Weeren, Reinout J.; Vergani, Daniela; Verheijen, Marc A. W.; Verro, Kristiina; Vink, Jorick S.; Vioque, Miguel; Walcher, C. Jakob; Walton, Nicholas A.; Wegg, Christopher; Weijmans, Anne-Marie; Williams, Wendy L.; Wilson, Andrew J.; Wright, Nicholas J.; Xylakis-Dornbusch, Theodora; Youakim, Kris; Zibetti, Stefano; Zurita, Cristina "The wide-field, multiplexed, spectroscopic facility WEAVE: Survey design, overview, and simulated implementation," *Monthly Notices of the Royal Astronomical Society*, 2212, , 2023.
- Jones, G. C.; Maiolino, R.; Carniani, S.; Circosta, C.; Fudamoto, Y.; Scholtz, J. "An investigation of the circumgalactic medium around  $z \sim 2.2$  AGN with ACA and ALMA," *Monthly Notices of the Royal Astronomical Society*, 522, 275, 2023.
- Jones, G. C.; Maiolino, R.; Circosta, C.; Scholtz, J.; Carniani, S.; Fudamoto, Y. "Evidence for extended gaseous reservoirs around AGN at cosmic noon from ALMA CO(3-2) observations," *Monthly Notices of the Royal Astronomical Society*, 518, 691, 2023.
- Jones, M. G.; Verdes-Montenegro, L.; Moldon, J.; Damas Segovia, A.; Borthakur, S.; Luna, S.; Yun, M.; Del Olmo, A.; Perea, J.; Cannon, J.; Lopez Gutierrez, D.; Cluver, M.; Garrido, J.; Sanchez, S. "Disturbed, diffuse, or just missing? A global study of the H I content of Hickson compact groups," *Astronomy and Astrophysics*, 670, A21, 2023.
- Jorstad, Svetlana; Wielgus, Maciek; Lico, Rocco; Issaoun, Sara; Broderick, Avery E.; Pesce, Dominic W.; Liu, Jun; Zhao, Guang-Yao; Krichbaum, Thomas P.; Blackburn, Lindy; Chan, Chi-Kwan; Janssen, Michael; Ramakrishnan, Venkatesh; Akiyama, Kazunori; Alberdi, Anton; Algaba, Juan Carlos; Bouman, Katherine L.; Cho, Ilje; Fuentes, Antonio; Gómez, José L.; Gurwell, Mark; Johnson, Michael D.; Kim, Jae-Young; Lu, Ru-Sen; Martí-Vidal, Iván; Mosciibrodzka, Monika; Pötzl, Felix M.; Traianou, Eftalia; Van Bemmel, Ilse; Alef, Walter; Anantua, Richard; Asada, Keiichi; Azulay, Rebecca; Bach, Uwe; Baczko, Anne-Kathrin; Ball, David; Baloković, Mislav; Barrett, John; Bauböck, Michi; Benson, Bradford A.; Bintley, Dan; Blundell, Raymond; Bower, Geoffrey C.; Boyce, Hope; Bremer, Michael; Brinkerink, Christiaan D.; Brissenden, Roger; Britzen, Silke; Brogiere, Dominique; Bronzwaer, Thomas; Bustamante, Sandra; Byun, Do-Young; Carlstrom, John E.; Ceccobello, Chiara; Chael, Andrew; Chatterjee, Koushik; Chatterjee, Shami; Chen, Ming-Tang; Chen, Yongjun; Cheng, Xiaopeng; Christian, Pierre; Conroy, Nicholas S.; Conway, John E.; Cordes, James M.; Crawford, Thomas M.; Crew, Geoffrey B.; Cruz-Osorio, Alejandro; Cui, Yuzhu; Davelaar, Jordy; De Laurentis, Mariafelicia; Deane, Roger; Dempsey, Jessica; Desvignes, Gregory; Dexter, Jason; Dhruv, Vedant; Doleman,

## APPENDIX A: PUBLICATIONS

- Sheperd S.; Dougal, Sean; Dzib, Sergio A.; Eatough, Ralph P.; Emami, Razieh; Falcke, Heino; Farah, Joseph; Fish, Vincent L.; Fomalont, Ed; Ford, H. Alyson; Fraga-Encinas, Raquel; Freeman, William T.; Friberg, Per; Fromm, Christian M.; Galison, Peter; Gammie, Charles F.; García, Roberto; Gentaz, Olivier; Georgiev, Boris; Goddi, Ciriaco; Gold, Roman; Gómez-Ruiz, Arturo I.; Gu, Minfeng; Hada, Kazuhiro; Haggard, Daryl; Haworth, Kari; Hecht, Michael H.; Hesper, Ronald; Heumann, Dirk; Ho, Luis C.; Ho, Paul; Honma, Mareki; Huang, Chih-Wei L.; Huang, Lei; Hughes, David H.; Ikeda, Shiro; Impellizzeri, C. M. Violette; Inoue, Makoto; James, David J.; Jannuzi, Buell T.; Jeter, Britton; Jiang, Wu; Jiménez-Rosales, Alejandra; Joshi, Abhishek V.; Jung, Taehyun; Karami, Mansour; Karuppusamy, Ramesh; Kawashima, Tomohisa; Keating, Garrett K.; Kettenis, Mark; Kim, Dong-Jin; Kim, Jongsoo; Kim, Junhan; Kino, Motoki; Koay, Jun Yi; Kocherlakota, Prashant; Kofuji, Yutaro; Koyama, Shoko; Kramer, Carsten; Kramer, Michael; Kuo, Cheng-Yu; La Bella, Noemi; Lauer, Tod R.; Lee, Daeyoung; Lee, Sang-Sung; Leung, Po Kin; Levis, Aviad; Li, Zhiyuan; Lindahl, Greg; Lindqvist, Michael; Lisakov, Mikhail; Liu, Kuo; Liuzzo, Elisabetta; Lo, Wen-Ping; Lobanov, Andrei P.; Loinard, Laurent; Lonsdale, Colin J.; Macdonald, Nicholas R.; Mao, Jirong; Marchili, Nicola; Markoff, Sera; Marrone, Daniel P.; Marscher, Alan P.; Matsushita, Satoki; Matthews, Lynn D.; Medeiros, Lia; Menten, Karl M.; Michalik, Daniel; Mizuno, Izumi; Mizuno, Yosuke; Moran, James M.; Moriyama, Kotaro; Müller, Cornelia; Mus, Alejandro; Musoke, Gibwa; Myserlis, Ioannis; Nadolski, Andrew; Nagai, Hiroshi; Nagar, Neil M.; Nakamura, Masanori; Narayan, Ramesh; Narayanan, Gopal; Natarajan, Iniyani; Nathanail, Antonios; Fuentes, Santiago Navarro; Neilsen, Joey; Neri, Roberto; Ni, Chunhong; Noutsos, Aristeidis; Nowak, Michael A.; Oh, Junghwan; Okino, Hiroki; Olivares, Héctor; Ortiz-León, Gisela N.; Oyama, Tomoaki; Özel, Feryal; Palumbo, Daniel C. M.; Paraschos, Georgios Filippou; Park, Jongho; Parsons, Harriet; Patel, Nimesh; Pen, Ue-Li; Piétu, Vincent; Plambeck, Richard; Popstefanija, Aleksandar; Porth, Oliver; Prather, Ben; Preciado-López, Jorge A.; Psaltis, Dimitrios; Pu, Hung-Yi; Rao, Ramprasad; Rawlings, Mark G.; Raymond, Alexander W.; Rezzolla, Luciano; Ricarte, Angelo; Ripperda, Bart; Roelofs, Freek; Rogers, Alan; Ros, Eduardo; Romero-Cañizales, Cristina; Roshanineshat, Arash; Rottmann, Helge; Roy, Alan L.; Ruiz, Ignacio; Ruszczyk, Chet; Rygl, Kazi L. J.; Sánchez, Salvador; Sánchez-Argüelles, David; Sánchez-Portal, Miguel; Sasada, Mahito; Satpathy, Kaushik; Savolainen, Tuomas; Schloerb, F. Peter; Schonfeld, Jonathan; Schuster, Karl-Friedrich; Shao, Lijing; Shen, Zhiqiang; Small, Des; Sohn, Bong Won; Soohoo, Jason; Souccar, Kamal; Sun, He; Tazaki, Fumie; Tetarenko, Alexandra J.; Tiede, Paul; Tilanus, Remo P. J.; Titus, Michael; Torne, Pablo; Trent, Tyler; Trippé, Sascha; Turk, Matthew; Van Langevelde, Huib Jan; Van Rossum, Daniel R.; Vos, Jesse; Wagner, Jan; Ward-Thompson, Derek; Wardle, John; Weintraub, Jonathan; Wex, Norbert; Wharton, Robert; Wiik, Kaj; Witzel, Gunther; Wondrak, Michael F.; Wong, George N.; Wu, Qingwen; Yamaguchi, Paul; Yoon, Doosoo; Young, André; Young, Ken; Younsi, Ziri; Yuan, Feng; Yuan, Ye-Fei; Zensus, J. Anton; Zhang, Shuo; Zhao, Shan-Shan "The Event Horizon Telescope Image of the Quasar NRAO 530," *The Astrophysical Journal*, 943, 170, 2023.
- Kaasinen, M.; Van Marrewijk, J.; Popping, G.; Ginolfi, M.; Di Mascolo, L.; Mroczkowski, T.; Concas, A.; Di Cesare, C.; Killi, M.; Langan, I. "To see or not to see a  $z \sim 13$  galaxy, that is the question. Targeting the [C II] 158  $\mu\text{m}$  emission line of HD1 with ALMA," *Astronomy and Astrophysics*, 671, A29, 2023.
- Kade, K.; Knudsen, K. K.; Vlemmings, W.; Stanley, F.; Gullberg, B.; König, S. "Exploring the environment, magnetic fields, and feedback effects of massive high-redshift galaxies with [C II]," *Astronomy and Astrophysics*, 673, A116, 2023.
- Kameno, Seiji; Harikane, Yuichi; Sawada-Satoh, Satoko; Sawada, Tsuyoshi; Saito, Toshiki; Nakanishi, Kouichiro; Humphreys, Elizabeth "ALMA detection of 321 GHz water maser emission in the radio galaxy NGC 1052," *Publications of the Astronomical Society of Japan*, 75, L1, 2023.
- Kameno, Seiji; Sawada-Satoh, Satoko; Impellizzeri, C. M. Violette; Kohno, Kotaro; Martín, Sergio; Espada, Daniel; Nakai, Naomasa; Sugai, Hajime; Terashima, Yuichi; Lee, Minju M.; Kawakatu, Nozomu "Probing the Jet-Torus Interaction in the Radio Galaxy NGC 1052 by Sulfur-bearing Molecules," *The Astrophysical Journal*, 944, 156, 2023.
- Kamienieski, Patrick S.; Frye, Brenda L.; Pascale, Massimo; Cohen, Seth H.; Windhorst, Rogier A.; Jansen, Rolf A.; Yun, Min S.; Cheng, Cheng; Summers, Jake S.; Carleton, Timothy; Harrington, Kevin C.; Diego, Jose M.; Yan, Haojing; Koekemoer, Anton M.; Willmer, Christopher N. A.; Petric, Andreea; Furtak, Lukas J.; Foo, Nicholas; Conselice, Christopher J.; Coe, Dan; Driver, Simon P.; Grogin, Norman A.; Marshall, Madeline A.; Nonino, Mario; Pirzkal, Nor; Robotham, Aaron S. G.; Ryan, Russell E.; Tompkins, Scott "Are JWST/NIRCam Color Gradients in the Lensed  $z = 2.3$  Dusty Star-forming Galaxy El Anzuelo Due to Central Dust Attenuation or Inside-out Galaxy Growth?," *The Astrophysical Journal*, 955, 91, 2023.
- Kaminsky, Aidan; Bonne, Lars; Arzoumanian, Doris; Coudé, Simon "On the 3D Curvature and Dynamics of the Musca Filament," *The Astrophysical Journal*, 948, 109, 2023.
- Kaneko, Hiroyuki; Tokita, Shoya; Kuno, Nario "Investigating physical states of molecular gas in the overlapping region of interacting galaxies NGC 4567/4568 using ALMA," *Publications of the Astronomical Society of Japan*, 75, 646, 2023.
- Kang, Xiaoyu; Kudritzki, Rolf-Peter; Zhang, Fenghui "The growth history of local M 33-mass bulgeless spiral galaxies," *Astronomy and Astrophysics*, 679, A83, 2023.
- Kao, Melodie M.; Mioduszewski, Amy J.; Villadsen, Jackie; Shkolnik, Evgenya L. "Resolved imaging confirms a radiation belt around an ultracool dwarf," *Nature*, 619, p.272-275, 2023.
- Karoly, Janik; Ward-Thompson, Derek; Pattle, Kate; Berry, David; Whitworth, Anthony; Kirk, Jason; Bastien, Pierre; Ching, Tao-Chung; Coudé, Simon; Hwang, Jihye; Kwon, Woojin; Soam, Archana; Wang, Jia-Wei; Hasegawa, Tetsuo; Lai, Shih-Ping; Qiu, Keping; Arzoumanian, Doris; Bourke, Tyler L.; Byun, Do-Young; Chen, Hwei-Ru Vivien; Chen, Wen Ping; Chen, Mike; Chen, Zhiwei; Cho, Jungyeon; Choi, Minhoo; Choi, Youngwoo; Choi, Yunhee; Chrysostomou, Antonio; Chung, Eun Jung; Dai, Sophia; Debattista, Victor; Di Francesco, James; Diep, Pham Ngoc; Doi, Yasuo; Duan, Hao-Yuan; Duan, Yan; Eswaraiah, Chakali; Fanciullo, Lapo; Fiege, Jason; Fissel, Laura M.; Franzmann, Erica; Friberg, Per; Friesen, Rachel; Fuller, Gary; Furuya, Ray; Gledhill, Tim; Graves, Sarah; Greaves, Jane; Griffin, Matt; Gu, Qilao; Han, Ilseung; Hoang, Thiem; Houde, Martin; Hull, Charles L. H.; Inoue, Tsuyoshi; Inutsuka, Shu-Ichiro; Iwasaki, Kazunari; Jeong, Il-Gyo; Johnstone, Doug; Könyves, Vera; Kang, Ji-Hyun; Kang, Miju; Kataoka, Akimasa; Kawabata, Koji; Kemper, Francisca; Kim, Jongsoo; Kim, Shinyoung; Kim, Gwanjeong; Kim, Kyoung Hee; Kim, Mi-Ryang; Kim, Kee-Tae; Kim, Hyosung; Kirchschrager, Florian; Kobayashi, Masato I. N.; Koch, Patrick M.; Kusune, Takayoshi; Kwon, Jungmi; Lacaille, Kevin; Law, Chi-Yan; Lee, Chang Won; Lee, Hyesung; Lee, Yong-Hee; Lee, Chin-Fei; Lee, Jeong-Eun; Lee, Sang-Sung; Li, Dalei; Li, Di; Li, Guangxing; Li, Hua-Bai; Lin, Sheng-Jun; Liu, Hong-Li; Liu, Tie; Liu, Sheng-Yuan; Liu, Junhao; Longmore, Steven; Lu, Xing; Lyo, A. -Ran; Mairs, Steve; Matsumura, Masafumi; Matthews, Brenda; Moriarty-Schieven, Gerald; Nagata, Tetsuya; Nakamura, Fumitaka; Nakanishi, Hiroyuki; Ngoc, Nguyen Bich; Ohashi, Nagayoshi; Onaka, Takashi; Park, Geumsook; Parsons, Harriet; Peretto, Nicolas; Priestley, Felix; Pyo, Tae-Soo; Qian, Lei; Rao, Ramprasad; Rawlings, Jonathan; Rawlings, Mark; Retter, Brendan; Richer, John; Rigby, Andrew; Sadavoy, Sarah; Saito, Hiro; Savini, Giorgio; Seta, Masumichi; Sharma, Ekta; Shimajiri, Yoshito; Shinnaga, Hiroko; Tahani, Mehrnoosh; Tamura, Motohide; Tang, Ya-Wen; Tang, Xindi; Tomisaka, Kohji; Tram, Le Ngoc; Tsukamoto, Yusuke; Viti, Serena; Wang, Hongchi; Wu, Jintai; Xie, Jinjin; Yang, Meng-Zhe; Yen, Hsi-Wei; Yoo, Hyunju; Yuan, Jinghua; Yun, Hyeong-Sik; Zenko, Tetsuya; Zhang, Guoyin; Zhang, Yapeng; Zhang, Chuan-Peng; Zhou, Jianjun; Zhu, Lei; De Looze, Ilse; André, Philippe; Dowell, C. Darren; Eden, David; Eyres, Stewart; Falle, Sam; Le Gouellec, Valentin J. M.; Poidevin, Frédéric;

- Robitaille, Jean-François; Van Loo, Sven "The JCMT BISTRO Survey: Studying the Complex Magnetic Field of L43," *The Astrophysical Journal*, 952, 29, 2023.
- Kashino, Daichi; Lilly, Simon J.; Simcoe, Robert A.; Bordoloi, Rongmon; Mackenzie, Ruari; Matthee, Jorryt; Eilers, Anna-Christina "Compact [C II] emitters around a C IV absorption complex at redshift 5.7," *Nature*, 617, 261, 2023.
- Katsioli, S.; Xilouris, E. M.; Kramer, C.; Adam, R.; Ade, P.; Ajeddig, H.; André, P.; Artis, E.; Aussel, H.; Baes, M.; Beelen, A.; Benoît, A.; Berta, S.; Bing, L.; Bourrion, O.; Calvo, M.; Catalano, A.; Clark, C. J. R.; De Looze, I.; De Petris, M.; Désert, F.-X.; Doyle, S.; Driessen, E. F. C.; Ejlali, G.; Galametz, M.; Galliano, F.; Gomez, A.; Goupy, J.; Hanser, C.; Hughes, A.; Jones, A. P.; Kéruzoré, F.; Ladjelate, B.; Lagache, G.; Leclercq, S.; Lestrade, J.-F.; Macías-Pérez, J.-F.; Madden, S. C.; Maury, A.; Mauskopf, P.; Mayet, F.; Monfardini, A.; Muñoz-Echeverría, M.; Nersesian, A.; Pantoni, L.; Paradis, D.; Perotto, L.; Pisano, G.; Ponthieu, N.; Revéret, V.; Rigby, A. J.; Ritacco, A.; Romero, C.; Roussel, H.; Ruppin, F.; Schuster, K.; Sievers, A.; Smith, M. W. L.; Tedros, J.; Tabatabaei, F.; Tucker, C.; Ysard, N.; Zylka, R. "The stratification of ISM properties in the edge-on galaxy NGC 891 revealed by NKA2," *Astronomy and Astrophysics*, 679, A7, 2023.
- Kawamuro, Taiki; Ricci, Claudio; Mushotzky, Richard F.; Imanishi, Masatoshi; Bauer, Franz E.; Ricci, Federica; Koss, Michael J.; Prion, George C.; Trakhtenbrot, Benny; Izumi, Takuma; Ichikawa, Kohei; Rojas, Alejandra F.; Smith, Krista Lynne; Shimizu, Taro; Oh, Kyuseok; Den Brok, Jakob S.; Baba, Shunsuke; Baloković, Mislav; Chang, Chin-Shin; Kakkad, Darshan; Pfeifle, Ryan W.; Temple, Matthew J.; Ueda, Yoshihiro; Harrison, Fiona; Powell, Meredith C.; Stern, Daniel; Urry, Meg; Sanders, David B. "BASS. XXXIV. A Catalog of the Nuclear Millimeter-wave Continuum Emission Properties of AGNs Constrained on Scales  $\leq 100$ -200 pc," *The Astrophysical Journal Supplement Series*, 269, 24, 2023.
- Keller, Pascal M.; Nikolic, Bojan; Thyagarajan, Nithyanandan; Carilli, Chris L.; Bernardi, Gianni; Charles, Ntsikelelo; Bester, Landman; Smirnov, Oleg M.; Kern, Nicholas S.; Dillon, Joshua S.; Hazelton, Bryna J.; Morales, Miguel F.; Jacobs, Daniel C.; Parsons, Aaron R.; Abdurashidova, Zara; Adams, Tyrone; Aguirre, James E.; Alexander, Paul; Ali, Zaki S.; Baartman, Rushelle; Balfour, Yanga; Beardsley, Adam P.; Billings, Tashalee S.; Bowman, Judd D.; Bradley, Richard F.; Bull, Philip; Burba, Jacob; Carey, Steven; Cheng, Carina; Deboer, David R.; De Lera Acedo, Eloy; Dexter, Matt; Eksteen, Nico; Ely, John; Ewall-Wice, Aaron; Fagnoni, Nicolas; Fritz, Randall; Furlanetto, Steven R.; Gale-Sides, Kingsley; Glendenning, Brian; Gorthi, Deepthi; Greig, Bradley; Grobelaar, Jasper; Halday, Ziyaad; Hewitt, Jacqueline N.; Hickish, Jack; Julius, Austin; Kariseb, Maccalvin; Kerrigan, Joshua; Kittiwisit, Piyanat; Kohn, Saul A.; Kolopanis, Matthew; Lanman, Adam; Plante, Paul La; Liu, Adrian; Loots, Anita; Ma, Yin-Zhe; Macmahon, David Harold Edward; Malan, Laurence; Malgas, Cresshim; Malgas, Keith; Marero, Bradley; Martinot, Zachary E.; Mesinger, Andrei; Molewa, Mathakane; Mosiane, Tshegofalang; Murray, Steven G.; Neben, Abraham R.; Nuwegeld, Hans; Pascua, Robert; Patra, Nipanjana; Pieterse, Samantha; Pober, Jonathan C.; Razavi-Ghods, Nima; Robnett, James; Rosie, Kathryn; Santos, Mario G.; Sims, Peter; Smith, Craig; Swarts, Hilton; Van Wyngaarden, Pieter; Williams, Peter K. G.; Zheng, Haoxuan "Search for the Epoch of Reionization with HERA: upper limits on the closure phase delay power spectrum," *Monthly Notices of the Royal Astronomical Society*, 524, 583, 2023.
- Kellermann, Kenneth I. "Book Review: The ALMA Telescope: The Story of a Science Mega-Project," *Journal of Astronomical History and Heritage*, 26, 753, 2023.
- Kennedy, Grant M.; Lovell, Joshua B.; Kalas, Paul; Fitzgerald, Michael P. "ALMA and Keck analysis of Fomalhaut field sources: JWST's Great Dust Cloud is a background object," *Monthly Notices of the Royal Astronomical Society*, 524, 2698, 2023.
- Kesebonye, K. C.; Hilton, M.; Knowles, K.; Cotton, W. D.; Clarke, T. E.; Loubser, S. I.; Moodley, K.; Sikhosana, S. P. "The MeerKAT Galaxy Clusters Legacy Survey: star formation in massive clusters at  $0.15 < z < 0.35$ ," *Monthly Notices of the Royal Astronomical Society*, 518, 3004, 2023.
- Keyte, Luke; Kama, Mihkel; Booth, Alice S.; Bergin, Edwin A.; Cleeves, L. I.; Sedore, Van Dishoeck, Ewine F.; Drozdovskaya, Maria N.; Furuya, Kenji; Rawlings, Jonathan; Shorttle, Oliver; Walsh, Catherine "Azimuthal C/O variations in a planet-forming disk," *Nature Astronomy*, 7, 684, 2023.
- Khabibullin, I. I.; Churazov, E. M.; Bykov, A. M.; Chugai, N. N.; Sunyaev, R. A. "SRG/eROSITA discovery of a radio-faint X-ray candidate supernova remnant SRGe J003602.3+605421 = G1211-1.9," *Monthly Notices of the Royal Astronomical Society*, 521, 5536, 2023.
- Kido, Miyu; Takakuwa, Shigehisa; Saigo, Kazuya; Ohashi, Nagayoshi; Tobin, John J.; Jørgensen, Jes K.; Aikawa, Yuri; Aso, Yusuke; Encalada, Frankie J.; Flores, Christian; Gavino, Sacha; De Gregorio-Monsalvo, Itziar; Han, Ilseung; Hirano, Shingo; Koch, Patrick M.; Kwon, Woojin; Lai, Shih-Ping; Lee, Chang Won; Lee, Jeong-Eun; Li, Zhi-Yun; Lin, Zhe-Yu Daniel; Looney, Leslie W.; Mori, Shoji; Narayanan, Suchitra; Plunkett, Adele L.; Phuong, Nguyen Thi; (Insa Choi), Jinshi Sai; Santamaría-Miranda, Alejandro; Sharma, Rajeeb; Sheehan, Patrick D.; Thieme, Travis J.; Tomida, Kengo; Van'T Hoff, Merel L. R.; Williams, Jonathan P.; Yamato, Yoshihide; Yen, Hsi-Wei "Early Planet Formation in Embedded Disks (eDisk). VII. Keplerian Disk, Disk Substructure, and Accretion Streamers in the Class 0 Protostar IRAS 16544-1604 in CB 68," *The Astrophysical Journal*, 953, 190, 2023.
- Killi, Meghana; Watson, Darach; Fujimoto, Seiji; Akins, Hollis; Knudsen, Kirsten; Richard, Johan; Harikane, Yuichi; Rigopoulou, Dimitra; Rizzo, Francesca; Ginolfi, Michele; Popping, Gergő; Kokorev, Vasily "A solar metallicity galaxy at  $z > 7$ ? Possible detection of the [N II] 122  $\mu\text{m}$  and [O III] 52  $\mu\text{m}$  lines," *Monthly Notices of the Royal Astronomical Society*, 521, 2526, 2023.
- Kim, Changseok; Woo, Jong-Hak; Luo, Rongxin; Chung, Aeree; Baek, Junhyun; Le, Huynh Anh N.; Son, Donghoon "Unraveling the Complex Structure of AGN-driven Outflows. VI. Strong Ionized Outflows in Type 1 AGNs and the Outflow Size-Luminosity Relation," *The Astrophysical Journal*, 958, 145, 2023.
- Kim, Dae-Won; Janssen, Michael; Krichbaum, Thomas P.; Boccardi, Bia; Macdonald, Nicholas R.; Ros, Eduardo; Lobanov, Andrei P.; Zensus, J. Anton "First GMVA observations with the upgraded NOEMA facility: VLBI imaging of BL Lacertae in a flaring state," *Astronomy and Astrophysics*, 680, L3, 2023.
- Kim, Dong-Woo; Malnati, Amanda; Cassity, Alyssa; Fabbiano, Giuseppina; Martínez Galarza, Juan Rafael; O'Sullivan, Ewan "Revisiting X-Ray-bright Optically Normal Galaxies with the Chandra Source Catalog," *The Astrophysical Journal*, 955, 56, 2023.
- Kim, Honggeun; Kern, Nicholas S.; Hewitt, Jacqueline N.; Nhan, Bang D.; Dillon, Joshua S.; De Lera Acedo, Eloy; Dynes, Scott B. C.; Mahesh, Nivedita; Fagnoni, Nicolas; Deboer, David R. "The Impact of Beam Variations on Power Spectrum Estimation for 21 cm Cosmology. II. Mitigation of Foreground Systematics for HERA," *The Astrophysical Journal*, 953, 136, 2023.
- Kim, Jaeyeon; Chevance, Mélanie; Kruijssen, J. M. Diederik; Barnes, Ashley T.; Bigiel, Frank; Blanc, Guillermo A.; Boquien, Médéric; Cao, Yixian; Congiu, Enrico; Dale, Daniel A.; Egorov, Oleg V.; Faesi, Christopher M.; Glover, Simon C. O.; Grasha, Kathryn; Groves, Brent; Hassani, Hamid; Hughes, Annie; Klessen, Ralf S.; Kreckel, Kathryn; Larson, Kirsten L.; Lee, Janice C.; Leroy, Adam K.; Liu, Daizhong; Longmore, Steven N.; Meidt, Sharon E.; Pan, Hsi-An; Pety, Jérôme; Querejeta, Miguel; Rosolowsky, Erik; Saito, Toshiki; Sandstrom, Karin; Schinnerer, Eva; Smith, Rowan J.; Usero, Antonio; Watkins, Elizabeth J.; Williams, Thomas G. "PHANGS-JWST First Results: Duration of the Early Phase of Massive Star Formation in NGC 628," *The Astrophysical Journal*, 944, L20, 2023.
- Kim, Jae-Young; Savolainen, Tuomas; Voitsik, Petr; Kravchenko, Evgeniya V.; Lisakov, Mikhail M.; Kovalev, Yuri Y.; Müller, Hendrik; Lobanov, Andrei P.; Sokolovsky, Kirill V.; Bruni, Gabriele; Edwards, Philip G.; Reynolds,

## APPENDIX A: PUBLICATIONS

- Cormac; Bach, Uwe; Gurvits, Leonid I.; Krichbaum, Thomas P.; Hada, Kazuhiro; Giroletti, Marcello; Orienti, Monica; Anderson, James M.; Lee, Sang-Sung; Sohn, Bong Won; Zensus, J. Anton "RadioAstron Space VLBI Imaging of the Jet in M87. I. Detection of High Brightness Temperature at 22 GHz," *The Astrophysical Journal*, 952, 34, 2023.
- Kim, Jin-Ah; Jones, Terry Jay; Dowell, C. Darren "Exploring the Magnetic Field Geometry in NGC 891 with SOFIA/HAWC+," *The Astronomical Journal*, 165, 223, 2023.
- Kitayama, Tetsu; Ueda, Shutaro; Okabe, Nobuhiro; Akahori, Takuya; Hilton, Matt; Hughes, John P.; Ichinohe, Yuto; Kohno, Kotaro; Komatsu, Eiichiro; Lin, Yen-Ting; Miyatake, Hironao; Oguri, Masamune; Sifón, Cristóbal; Takakuwa, Shigehisa; Takizawa, Motokazu; Tsutsumi, Takahiro; Van Marrewijk, Joshiwa; Wollack, Edward J. "Galaxy clusters at  $z \sim 1$  imaged by ALMA with the Sunyaev-Zel'dovich effect," *Publications of the Astronomical Society of Japan*, 75, 311-337, 2023.
- Klitsch, Anne; Davis, Timothy A.; Hamanowicz, Aleksandra; Van De Voort, Freeke; Péroux, Céline; Zwaan, Martin A. "ALMACAL - X. Constraints on molecular gas in the low-redshift circumgalactic medium," *Monthly Notices of the Royal Astronomical Society*, 523, L46, 2023.
- Kobak, A.; Bartkiewicz, A.; Szymczak, M.; Olech, M.; Durjasz, M.; Wolak, P.; Chibueze, J. O.; Hirota, T.; Eislöffel, J.; Stecklum, B.; Sobolev, A.; Bayandina, O.; Orosz, G.; Burns, R. A.; Kim, K.-T.; Van Den Heever, S. P. "Multi-frequency VLBI observations of maser lines during the 6.7 GHz maser flare in the high-mass young stellar object G24.33+0.14," *Astronomy and Astrophysics*, 671, A135, 2023.
- Koda, Jin; Hirota, Akihiko; Egusa, Fumi; Sakamoto, Kazushi; Sawada, Tsuyoshi; Heyer, Mark; Baba, Junichi; Boissier, Samuel; Calzetti, Daniela; Meyer, Jennifer Donovan; Elmegreen, Bruce G.; De Paz, Armando Gil; Harada, Nanase; Ho, Luis C.; Kobayashi, Masato I. N.; Kuno, Nario; Lee, Amanda M.; Madore, Barry F.; Maeda, Fumiya; Martín, Sergio; Muraoka, Kazuyuki; Nakanishi, Kouichiro; Onodera, Sachiko; Pineda, Jorge L.; Scoville, Nick; Watanabe, Yoshimasa "Diverse Molecular Structures across the Whole Star-forming Disk of M83: High-fidelity Imaging at 40 pc Resolution," *The Astrophysical Journal*, 949, 108, 2023.
- Kokorev, Vasily; Jin, Shuowen; Gómez-Guijarro, Carlos; Magdis, Georgios E.; Valentino, Francesco; Lee, Minju M.; Daddi, Emanuele; Liu, Daizhong; Sargent, Mark T.; Trebitsch, Maxime; Weaver, John R. "Dust giant: Extended and clumpy star-formation in a massive dusty galaxy at  $z = 1.38$ ," *Astronomy and Astrophysics*, 677, A172, 2023.
- Kokorev, Vasily; Jin, Shuowen; Magdis, Georgios E.; Caputi, Karina I.; Valentino, Francesco; Dayal, Pratika; Trebitsch, Maxime; Brammer, Gabriel; Fujimoto, Seiji; Bauer, Franz; Iani, Edoardo; Kohno, Kotaro; Blázquez Sesé, David; Gómez-Guijarro, Carlos; Rinaldi, Pierluigi; Navarro-Carrera, Rafael "JWST Insight into a Lensed HST-dark Galaxy and Its Quiescent Companion at  $z = 2.58$ ," *The Astrophysical Journal*, 945, L25, 2023.
- Koley, Atanu "Studying the internal structures of the central region of prestellar core L1517B in Taurus molecular cloud using ammonia (NH<sub>3</sub>) (1,1) and (2,2) lines," *Publications of the Astronomical Society of Australia*, 40, e053, 2023.
- Kolwa, S.; De Breuck, C.; Vernet, J.; Wylezalek, D.; Wang, W.; Popping, G.; Man, A. W. S.; Harrison, C. M.; Andreani, P. "Faint [C I](1-0) emission in  $z \sim 3.5$  radio galaxies," *Monthly Notices of the Royal Astronomical Society*, 525, 5831, 2023.
- Kong, Shuo; Arce, Héctor G.; Tobin, John J.; Zhang, Yichen; Maureira, María José; Kratter, Kaitlin M.; Pillai, Thushara G. S. "Binary Formation in a 100  $\mu$ m Dark Massive Core," *The Astrophysical Journal*, 950, 187, 2023.
- Koryukova, T. A.; Pushkarev, A. B.; Kiehlmann, S.; Readhead, A. C. S. "Multiple imaging of the quasar 2005 + 403 formed by anisotropic scattering," *Monthly Notices of the Royal Astronomical Society*, 526, 5932, 2023.
- Koss, Michael J.; Treister, Ezequiel; Kakkad, Darshan; Casey-Clyde, J. Andrew; Kawamuro, Taiki; Williams, Jonathan; Foord, Adi; Trakhtenbrot, Benny; Bauer, Franz E.; Privon, George C.; Ricci, Claudio; Mushotzky, Richard; Barcos-Munoz, Loreto; Blecha, Laura; Connor, Thomas; Harrison, Fiona; Liu, Tingting; Magno, Macon; Mingarelli, Chiara M. F.; Muller-Sanchez, Francisco; Oh, Kyuseok; Shimizu, T. Taro; Smith, Krista Lynne; Stern, Daniel; Tello, Miguel Parra; Urry, C. Megan "UGC 4211: A Confirmed Dual Active Galactic Nucleus in the Local Universe at 230 pc Nuclear Separation," *The Astrophysical Journal*, 942, L24, 2023.
- Kovakkuni, N.; Lelli, F.; Duc, P.-A.; Boquien, M.; Braine, J.; Brinks, E.; Charmandaris, V.; Combes, F.; Fensch, J.; Lisenfeld, U.; Mcgaugh, S. S.; Mihos, J. C.; Pawlowski, M. S.; Revaz, Y.; Weilbacher, P. M. "Molecular and ionized gas in tidal dwarf galaxies: the spatially resolved star formation relation," *Monthly Notices of the Royal Astronomical Society*, 526, 1940, 2023.
- Kremer, Kyle; Fuller, Jim; Piro, Anthony L.; Ransom, Scott M. "Connecting the young pulsars in Milky Way globular clusters with white dwarf mergers and the M81 fast radio burst," *Monthly Notices of the Royal Astronomical Society*, 525, L22, 2023.
- Kukreti, Pranav; Morganti, Raffaella; Tadhunter, Clive; Santoro, Francesco "Ionised gas outflows over the radio AGN life cycle," *Astronomy and Astrophysics*, 674, A198, 2023.
- Kumar, P.; Schinzel, F. K.; Taylor, G. B.; Kerr, M.; Castro, D.; Rau, U.; Bhatnagar, S. "Resolving the Bow Shock and Tail of the Cannonball Pulsar PSR J0002+6216," *The Astrophysical Journal*, 945, 129, 2023.
- Kumari, Sangita; Bhattacharyya, Bhaswati; Kansabanik, Devojyoti; Roy, Jayanta "Decade-long Timing Study of the Black Widow Millisecond Pulsar J1544+4937," *The Astrophysical Journal*, 942, 87, 2023.
- Kun, E.; Britzen, S.; Frey, S.; Gabányi, K. É.; Gergely, L. Á. "Signatures of a spinning supermassive black hole binary on the mas-scale jet of the quasar S5 1928+738 based on 25 yr of VLBI data," *Monthly Notices of the Royal Astronomical Society*, 526, 4698, 2023.
- Kushwahaa, Tanya; Drozdovskaya, Maria N.; Tychoniec, Łukasz; Tabone, Benoît "ALMA ACA study of the H<sub>2</sub>S/OCS ratio in low-mass protostars," *Astronomy and Astrophysics*, 672, A122, 2023.
- Kynoch, Daniel; Mitchell, Jake A. J.; Ward, Martin J.; Done, Chris; Lusso, Elisabeta; Landt, Hermine "The SOUX AGN sample: SDSS-XMM-Newton optical, ultraviolet, and X-ray selected active galactic nuclei spanning a wide range of parameter space - sample definition," *Monthly Notices of the Royal Astronomical Society*, 520, 2781, 2023.
- Lah, Philip; Onken, Christopher A.; Norris, Ray P.; D'Eugenio, Francesco "Ultrafuminous quasars at high redshift show evolution in their radio-loudness fraction in both redshift and ultraviolet luminosity," *Monthly Notices of the Royal Astronomical Society*, 525, 5291, 2023.
- Lai, Thomas S.-Y.; Armus, Lee; Bianchin, Marina; Díaz-Santos, Tanio; Linden, Sean T.; Privon, George C.; Inami, Hanae; U, Vivian; Bohn, Thomas; Evans, Aaron S.; Larson, Kirsten L.; Hensley, Brandon S.; Smith, J. -D. T.; Malkan, Matthew A.; Song, Yiqing; Stierwalt, Sabrina; Van Der Werf, Paul P.; Mckinney, Jed; Aalto, Susanne; Buiten, Victorine A.; Rich, Jeff; Charmandaris, Vassilis; Appleton, Philip; Barcos-Muñoz, Loreto; Böker, Torsten; Finnerty, Luke; Kader, Justin A.; Law, David R.; Medling, Anne M.; Brown, Michael J. I.; Hayward, Christopher C.; Howell, Justin; Iwasawa, Kazushi; Kemper, Francisca; Marshall, Jason; Mazzarella, Joseph M.; Müller-Sánchez, Francisco; Murphy, Eric J.; Sanders, David; Surace, Jason "GOALS-JWST: Small Neutral Grains and Enhanced 3.3  $\mu$ m PAH Emission in the Seyfert Galaxy NGC 7469," *The Astrophysical Journal*, 957, L26, 2023.
- Lambert, Trystan S.; Posses, A.; Aravena, M.; González-López, J.; Assef, R. J.; Díaz-Santos, T.; Brisbin, D.; Decarli, R.; Herrera-Camus, R.; Mejía, J.; Ricci, C. "An extended [C II] halo around a massive star-forming galaxy at  $z = 5.3$ ," *Monthly Notices of the Royal Astronomical Society*, 518, 3183, 2023.
- Laskar, Tanmoy; Alexander, Kate D.; Margutti, Raffaella; Eftekhari, Tarraneh; Chornock, Ryan; Berger, Edo; Cendes, Yvette; Duerr, Anne; Perley, Daniel A.; Ravasio, Maria Edvige; Yamazaki, Ryo; Ayache, Eliot H.; Barclay, Thomas; Barniol Duran, Rodolfo; Bhandari, Shivani; Brethauer, Daniel; Christy, Collin T.; Coppejans, Deanne L.; Duffell, Paul; Fong, Wen-Fai; Gomboc, Andreja; Guidorzi, Cristiano; Kennea, Jamie A.; Kobayashi, Shihō; Levan, Andrew; Lobanov, Andrei P.; Metzger, Brian



- D.; Ros, Eduardo; Schroeder, Genevieve; Williams, P. K. G. "The Radio to GeV Afterglow of GRB 221009A," *The Astrophysical Journal*, 946, L23, 2023.
- Lattanzi, V.; Alves, F. O.; Padovani, M.; Fontani, F.; Caselli, P.; Ceccarelli, C.; López-Sepulcre, A.; Favre, C.; Neri, R.; Chahine, L.; Vastel, C.; Evans, L. "SOLIS. XVII. Jet candidate unveiled in OMC-2 and its possible link to the enhanced cosmic-ray ionisation rate," *Astronomy and Astrophysics*, 671, A35, 2023.
- Law, Charles J.; Alarcón, Felipe; Cleeves, L. Isedore; Öberg, Karin I.; Paneque-Carreño, Teresa "CI Traces the Disk Atmosphere in the IM Lup Protoplanetary Disk," *The Astrophysical Journal*, 959, L27, 2023.
- Law, Charles J.; Booth, Alice S.; Öberg, Karin I. "SO and SiS Emission Tracing an Embedded Planet and Compact 12CO and 13CO Counterparts in the HD 169142 Disk," *The Astrophysical Journal*, 952, L19, 2023.
- Law, Charles J.; Teague, Richard; Öberg, Karin I.; Rich, Evan A.; Andrews, Sean M.; Bae, Jaehan; Benisty, Myriam; Facchini, Stefano; Flaherty, Kevin; Isella, Andrea; Jin, Sheng; Hashimoto, Jun; Huang, Jane; Loomis, Ryan A.; Long, Feng; Muñoz-Romero, Carlos E.; Paneque-Carreño, Teresa; Pérez, Laura M.; Qi, Chunhua; Schwarz, Kamber R.; Stadler, Jochen; Tsukagoshi, Takashi; Wilner, David J.; Van Der Plas, Gerrit "Mapping Protoplanetary Disk Vertical Structure with CO Isotopologue Line Emission," *The Astrophysical Journal*, 948, 60, 2023.
- Lazarova, Mariana S.; Canalizo, Gabriela; Lacy, Mark; Behn, Wyatt; Raub, Kaitlyn; Bennert, Vardha N.; Farrah, Duncan "The Nature of LoBAL QSOs. II. HST/WFC3 Observations Reveal Host Galaxies Dominated by Mergers," *The Astrophysical Journal*, 949, 69, 2023.
- Le Gouellec, V. J. M.; Maury, A. J.; Hull, C. L. H. "Physical conditions for dust grain alignment in Class 0 protostellar cores. I. Observations of dust polarization and molecular irradiation tracers," *Astronomy and Astrophysics*, 671, A167, 2023.
- Lebowitz, Sophie; Emonts, Bjorn; Terndrup, Donald M.; Burchett, Joseph N.; Prochaska, J. Xavier; Drouart, Guillaume; Villar-Martín, Montserrat; Lehnert, Matthew; De Breuck, Carlos; Vernet, Joël; Alatalo, Katherine "The Dragonfly Galaxy. III. Jet Brightening of a High-redshift Radio Source Caught in a Violent Merger of Disk Galaxies," *The Astrophysical Journal*, 951, 73, 2023.
- Lee, Chin-Fei; Jhan, Kai-Syun; Moraghan, Anthony "First Detection of a Linear Structure in the Midplane of the Young HH 211 Protostellar Disk: A Spiral Arm?," *The Astrophysical Journal*, 951, L2, 2023.
- Lee, Janice C.; Sandstrom, Karin M.; Leroy, Adam K.; Thilker, David A.; Schinnerer, Eva; Rosolowsky, Erik; Larson, Kirsten L.; Egorov, Oleg V.; Williams, Thomas G.; Schmidt, Judy; Emsellem, Eric; Anand, Gagandeep S.; Barnes, Ashley T.; Belfiore, Francesco; Bešlić, Ivana; Bigiel, Frank; Blanc, Guillermo A.; Bolatto, Alberto D.; Boquien, Médéric; Brok, Jakob Den; Cao, Yixian; Chandar, Rupali; Chastenet, Jérémy; Chevance, Mélanie; Chiang, I. -Da; Congiu, Enrico; Dale, Daniel A.; Deger, Sinan; Eibensteiner, Cosima; Faesi, Christopher M.; Glover, Simon C. O.; Grasha, Kathryn; Groves, Brent; Hassani, Hamid; Henny, Kiana F.; Henshaw, Jonathan D.; Hoyer, Nils; Hughes, Annie; Jeffreson, Sarah; Jiménez-Donaire, María J.; Kim, Jaeyeon; Kim, Hwihyun; Klessen, Ralf S.; Koch, Eric W.; Kreckel, Kathryn; Kruijssen, J. M. Diederik; Li, Jing; Liu, Daizhong; Lopez, Laura A.; Maschmann, Daniel; Chen, Ness Mayker; Meidt, Sharon E.; Murphy, Eric J.; Neumann, Justus; Neumayer, Nadine; Pan, Hsi-An; Pessa, Ismael; Pety, Jérôme; Querejeta, Miguel; Pinna, Francesca; Rodríguez, M. Jimena; Saito, Toshiki; Sánchez-Blázquez, Patricia; Santoro, Francesco; Sardone, Amy; Smith, Rowan J.; Sormani, Mattia C.; Scheuermann, Fabian; Stuber, Sophia K.; Sutter, Jessica; Sun, Jiayi; Teng, Yu-Hsuan; Treß, Robin G.; Usero, Antonio; Watkins, Elizabeth J.; Whitmore, Bradley C.; Razza, Alessandro "The PHANGS-JWST Treasury Survey: Star Formation, Feedback, and Dust Physics at High Angular Resolution in Nearby Galaxies," *The Astrophysical Journal*, 944, L17, 2023.
- Lee, Jeong-Eun; Baek, Giseon; Lee, Seokho; Jeong, Jae-Hong; Kim, Chul-Hwan; Aikawa, Yuri; Herczeg, Gregory J.; Johnstone, Doug; Tobin, John J. "Complex Organic Molecules in a Very Young Hot Corino, HOPS 373SW," *The Astrophysical Journal*, 956, 43, 2023.
- Lee, Jeong-Eun; Matsumoto, Tomoaki; Kim, Hyun-Jeong; Lee, Seokho; Harsono, Daniel; Bae, Jaehan; Evans, Neal J.; Ii, Inutsuka, Shu-Ichiro; Choi, Minh; Tatematsu, Ken'ichi; Lee, Jae-Joon; Jaffe, Daniel "Triple Spiral Arms of a Triple Protostar System Imaged in Molecular Lines," *The Astrophysical Journal*, 953, 82, 2023.
- Lee, Kianhong; Kohno, Kotaro; Hatsukade, Bunyo; Egusa, Fumi; Yamashita, Takuji; Schramm, Malte; Ichikawa, Kohei; Imanishi, Masatoshi; Izumi, Takuma; Nagao, Tohru; Toba, Yoshiki; Umehata, Hideki "Massive Molecular Gas Companions Uncovered by Very Large Array CO(1-0) Observations of the  $z = 5.2$  Radio Galaxy TN J0924-2201," *The Astrophysical Journal*, 944, 35, 2023.
- Leemker, M.; Booth, A. S.; Van Dishoeck, E. F.; Van Der Marel, N.; Tabone, B.; Ligterink, N. F. W.; Brunken, N. G. C.; Hogerheijde, M. R. "A major asymmetric ice trap in a planet-forming disk. IV. Nitric oxide gas and a lack of CN tracing sublimating ices and a C/O ratio  $< 1$ ," *Astronomy and Astrophysics*, 673, A7, 2023.
- Lei, Minjie; Clark, S. E. "Probing the Cold Neutral Medium through H I Emission Morphology with the Scattering Transform," *The Astrophysical Journal*, 947, 74, 2023.
- Lelli, Federico; Zhang, Zhi-Yu; Bisbas, Thomas G.; Lin, Lingrui; Papadopoulos, Padelis; Schombert, James M.; Di Teodoro, Enrico; Marasco, Antonino; Mcgaugh, Stacy S. "Cold gas disks in main-sequence galaxies at cosmic noon: Low turbulence, flat rotation curves, and disk-halo degeneracy," *Astronomy and Astrophysics*, 672, A106, 2023.
- Lenkić, Laura; Bolatto, Alberto D.; Fisher, Deanne B.; Abraham, Roberto; Glazebrook, Karl; Herrera-Camus, Rodrigo; Levy, Rebecca C.; Obreschkow, Danail; Volpert, Carolyn G. "CO Excitation in High- $z$  Main-sequence Analogues: Resolved CO(4-3)/CO(3-2) Line Ratios in DYNAMO Galaxies," *The Astrophysical Journal*, 945, 9, 2023.
- Leroy, Adam K.; Bolatto, Alberto D.; Sandstrom, Karin; Rosolowsky, Erik; Barnes, Ashley T.; Bigiel, F.; Boquien, Médéric; Den Brok, Jakob S.; Cao, Yixian; Chastenet, Jérémy; Chevance, Mélanie; Chiang, I. -Da; Chown, Ryan; Colombo, Dario; Ellison, Sara L.; Emsellem, Eric; Grasha, Kathryn; Henshaw, Jonathan D.; Hughes, Annie; Klessen, Ralf S.; Koch, Eric W.; Kim, Jaeyeon; Kreckel, Kathryn; Kruijssen, J. M. Diederik; Larson, Kirsten L.; Lee, Janice C.; Levy, Rebecca C.; Lin, Lihwai; Liu, Daizhong; Meidt, Sharon E.; Pety, Jérôme; Querejeta, Miguel; Rubio, Mónica; Saito, Toshiki; Salim, Samir; Schinnerer, Eva; Sormani, Mattia C.; Sun, Jiayi; Thilker, David A.; Usero, Antonio; Vogel, Stuart N.; Watkins, Elizabeth J.; Whitcomb, Cory M.; Williams, Thomas G.; Wilson, Christine D. "PHANGS-JWST First Results: A Global and Moderately Resolved View of Mid-infrared and CO Line Emission from Galaxies at the Start of the JWST Era," *The Astrophysical Journal*, 944, L10, 2023.
- Leroy, Adam K.; Sandstrom, Karin; Rosolowsky, Erik; Belfiore, Francesco; Bolatto, Alberto D.; Cao, Yixian; Koch, Eric W.; Schinnerer, Eva; Barnes, Ashley T.; Bešlić, Ivana; Bigiel, F.; Blanc, Guillermo A.; Chastenet, Jérémy; Chen, Ness Mayker; Chevance, Mélanie; Chown, Ryan; Congiu, Enrico; Dale, Daniel A.; Egorov, Oleg V.; Emsellem, Eric; Eibensteiner, Cosima; Faesi, Christopher M.; Glover, Simon C. O.; Grasha, Kathryn; Groves, Brent; Hassani, Hamid; Henshaw, Jonathan D.; Hughes, Annie; Jiménez-Donaire, María J.; Kim, Jaeyeon; Klessen, Ralf S.; Kreckel, Kathryn; Kruijssen, J. M. Diederik; Larson, Kirsten L.; Lee, Janice C.; Levy, Rebecca C.; Liu, Daizhong; Lopez, Laura A.; Meidt, Sharon E.; Murphy, Eric J.; Neumann, Justus; Pessa, Ismael; Pety, Jérôme; Saito, Toshiki; Sardone, Amy; Sun, Jiayi; Thilker, David A.; Usero, Antonio; Watkins, Elizabeth J.; Whitcomb, Cory M.; Williams, Thomas G. "PHANGS-JWST First Results: Mid-infrared Emission Traces Both Gas Column Density and Heating at 100 pc Scales," *The Astrophysical Journal*, 944, L9, 2023.
- Leung, James K.; Murphy, Tara; Lenc, Emil; Edwards, Philip G.; Ghirlanda, Giancarlo; Kaplan, David L.; O'Brien, Andrew; Wang, Ziteng "A matched-filter approach to radio variability and transients: searching for orphan afterglows in the VAST Pilot Survey," *Monthly Notices of the Royal Astronomical Society*, 523, 4029, 2023.

## APPENDIX A: PUBLICATIONS

- Levine, D.; Dainotti, M.; Fraija, N.; Warren, D.; Chandra, P.; Lloyd-Ronning, N. "Interpretation of radio afterglows in the framework of the standard fireball and energy injection models," *Monthly Notices of the Royal Astronomical Society*, 519, 4670-4683, 2023.
- Levy, Rebecca C.; Bolatto, Alberto D.; Tarantino, Elizabeth; Leroy, Adam K.; Armus, Lee; Emig, Kimberly L.; Herrera-Camus, Rodrigo; Marrone, Daniel P.; Mills, Elisabeth; Ricken, Oliver; Stutzki, Juergen; Veilleux, Sylvain; Walter, Fabian "[C II] Spectral Mapping of the Galactic Wind and Starbursting Disk of M82 with SOFIA," *The Astrophysical Journal*, 958, 109, 2023.
- Lewis, M. O.; Bhattacharya, R.; Sjouwerman, L. O.; Pihlström, Y. M.; Pietrzyński, G.; Sahai, R.; Karczmarek, P.; Górski, M. "Long-period maser-bearing Miras in the Galactic center. Period-luminosity relations and extinction estimates," *Astronomy and Astrophysics*, 677, A153, 2023.
- Li, Cheng; De Pater, Imke; Moeckel, Chris; Sault, R. J.; Butler, Bryan; Deboer, David; Zhang, Zhimeng "Long-lasting, deep effect of Saturn's giant storms," *Science Advances*, 9, eadg9419, 2023.
- Li, Dafa; Liu, Yao; Wang, Hongchi; Wang, Yao; Ma, Yuehui "The radial profile of dust grain size in the protoplanetary disc of DS Tau," *Monthly Notices of the Royal Astronomical Society*, 518, 6092, 2023.
- Li, Dongzi; Bilous, Anna; Ransom, Scott; Main, Robert; Yang, Yuan-Pei "A highly magnetized environment in a pulsar binary system," *Nature*, 618, 484, 2023.
- Li, Guodong; Tsai, Chao-Wei; Stern, Daniel; Wu, Jingwen; Assef, Roberto J.; Blain, Andrew W.; Díaz-Santos, Tanio; Eisenhardt, Peter R. M.; Griffith, Roger L.; Jarrett, Thomas H.; Jun, Hyunsung D.; Lake, Sean E.; Saade, M. Lynne "Discovery of a Low-redshift Hot Dust-obscured Galaxy," *The Astrophysical Journal*, 958, 162, 2023.
- Li, Jianrui; Emonts, Bjorn H. C.; Cai, Zheng; Li, Jianan; Battaia, Fabrizio Arrigoni; Prochaska, Jason X.; Yoon, Ilsang; Lehnert, Matthew D.; Sarazin, Craig; Wu, Yunjing; Lacy, Mark; Mason, Brian; Massingill, Kyle "The SUPERCOLD-CGM Survey. I. Probing the Extended CO(4-3) Emission of the Circumgalactic Medium in a Sample of 10 Enormous Ly $\alpha$  Nebulae at  $z \sim 2$ ," *The Astrophysical Journal*, 950, 180, 2023.
- Li, Liang; Wang, Yu; Ryde, Felix; Pe'Er, Asaf; Zhang, Bing; Guiriec, Sylvain; Castro-Tirado, Alberto J.; Kann, D. Alexander; Axelsson, Magnus; Page, Kim; Veres, Péter; Bhat, P. N. "A Cosmological Fireball with 16% Gamma-Ray Radiative Efficiency," *The Astrophysical Journal*, 944, L57, 2023.
- Li, Shang; Dai, Ji-Ping; Tan, Xiu-Hui; Yan, Yang-Jie; Xia, Jun-Qing "Searching for bounce signature in the early universe from current and future large-scale structure surveys," *Monthly Notices of the Royal Astronomical Society*, 521, 2357, 2023.
- Li, Shanghuo; Sanhueza, Patricio; Zhang, Qizhou; Guido, Garay; Sabatini, Giovanni; Morii, Kaho; Lu, Xing; Tafuya, Daniel; Nakamura, Fumitaka; Izumi, Natsuko; Tatematsu, Ken'Ichi; Li, Fei "The ALMA Survey of 70  $\mu\text{m}$  Dark High-mass Clumps in Early Stages (ASHES). VIII. Dynamics of Embedded Dense Cores," *The Astrophysical Journal*, 949, 109, 2023.
- Li, Wenhao; Nair, Preethi; Irwin, Jimmy; Ellison, Sara; Satyapal, Shobita; Drory, Niv; Jones, Amy; Keel, William; Masters, Karen; Stark, David; Ryan, Russell; Mukundan, Kavya "A Multiwavelength Study of Active Galactic Nuclei in Post-merger Remnants," *The Astrophysical Journal*, 944, 168, 2023.
- Li, Wenhao; Nair, Preethi; Rowlands, Kate; Masters, Karen; Stark, David; Drory, Niv; Ellison, Sara; Irwin, Jimmy; Satyapal, Shobita; Jones, Amy; Keel, William; Mukundan, Kavya; Tu, Zachary "Post-starburst properties of post-merger galaxies," *Monthly Notices of the Royal Astronomical Society*, 523, 720, 2023.
- Li, Yang-Ji; Liao, Neng-Hui; Sheng, Zhen-Feng; Chen, Sina; Wang, Yi-Bo; Wang, Ting-Gui "A  $\gamma$ -ray-emitting NLS1 galaxy, SDSS J095909.51+460014.3, identified by multi-wavelength contemporaneous brightening," *Astronomy and Astrophysics*, 676, A9, 2023.
- Lim, Seunghwan; Hill, Ryley; Scott, Douglas; Van Waerbeke, Ludovic; Cuillandre, Jean-Charles; Carlberg, Raymond G.; Chisari, Nora Elisa; Dvornik, Andrej; Erben, Thomas; Gwyn, Stephen; Mcconnachie, Alan W.; Miville-Deschênes, Marc-Antoine; Wright, Angus H.; Duc, Pierre-Alain "Constraints on galaxy formation from the cosmic-far-infrared-background - optical-imaging cross-correlation using Herschel and UNIONS," *Monthly Notices of the Royal Astronomical Society*, 525, 1443, 2023.
- Lin, Rebecca; Van Kerkwijk, Marten H.; Kirsten, Franz; Pen, Ue-Li; Deller, Adam T. "The Radio Parallax of the Crab Pulsar: A First VLBI Measurement Calibrated with Giant Pulses," *The Astrophysical Journal*, 952, 161, 2023.
- Lin, Ruqiu; Zheng, Zhen-Ya; Wang, Jun-Xian; Yuan, Fang-Ting; Rhoads, James E.; Malhotra, Sangeeta; An, Tao; Jiang, Chunyan; Zhu, Shuairu; Rahna, P. T.; Ji, Xiang; Singha, Mainak "Discovery of five Green pea galaxies with double-peaked narrow [O III] lines," *Monthly Notices of the Royal Astronomical Society*, 524, 2224, 2023.
- Lin, Xiaojing; Cai, Zheng; Zou, Siwei; Li, Zihao; Chen, Zuyi; Bian, Fuyan; Sun, Fengwu; Shu, Yiping; Wu, Yunjing; Li, Mingyu; Li, Jianan; Fan, Xiaohui; Prochaska, J. Xavier; Schaerer, Daniel; Charlot, Stephane; Espada, Daniel; Dessauges-Zavadsky, Miroslava; Egami, Eiichi; Stark, Daniel; Knudsen, Kirsten K.; Bruzual, Gustavo; Chevallard, Jacopo "Metal-enriched Neutral Gas Reservoir around a Strongly Lensed Low-mass Galaxy at  $z = 4$  Identified by JWST/NIRISS and VLT/MUSE," *The Astrophysical Journal*, 944, L59, 2023.
- Lin, Y.; Spezzano, S.; Pineda, J. E.; Harju, J.; Schmiedeke, A.; Jiao, S.; Liu, H. B.; Caselli, P. "Initial conditions of star formation at 2000 au: Physical structure and NH<sub>3</sub> depletion of three early-stage cores," *Astronomy and Astrophysics*, 680, A43, 2023.
- Lin, Zhe-Yu; Daniel, Li, Zhi-Yun; Tobin, John J.; Ohashi, Nagayoshi; Jorgensen, Jes Kristian; Looney, Leslie W.; Aso, Yusuke; Takakuwa, Shigehisa; Aikawa, Yuri; Van'T Hoff, Merel L. R.; De Gregorio-Monsalvo, Itziar; Encalada, Frankie J.; Flores, Christian; Gavino, Sacha; Han, Ilseung; Kido, Miyu; Koch, Patrick M.; Kwon, Woojin; Lai, Shih-Ping; Lee, Chang Won; Lee, Jeong-Eun; Phuong, Nguyen Thi; Sai Insa Choi, Jinshi; Sharma, Rajeeb; Sheehan, Patrick; Thieme, Travis J.; Williams, Jonathan P.; Yamato, Yoshihide; Yen, Hsi-Wei "Early Planet Formation in Embedded Disks (eDisk). II. Limited Dust Settling and Prominent Snow Surfaces in the Edge-on Class I Disk IRAS 04302+2247," *The Astrophysical Journal*, 951, 9, 2023.
- Linden, Sean T.; Evans, Aaron S.; Armus, Lee; Rich, Jeffrey A.; Larson, Kirsten L.; Lai, Thomas; Privon, George C.; U, Vivian; Inami, Hanae; Bohn, Thomas; Song, Yiqing; Barcos-Muñoz, Loreto; Charmandaris, Vassilis; Medling, Anne M.; Stierwalt, Sabrina; Diaz-Santos, Tanio; Böker, Torsten; Van Der Werf, Paul; Aalto, Susanne; Appleton, Philip; Brown, Michael J. I.; Hayward, Christopher C.; Howell, Justin H.; Iwasawa, Kazushi; Kemper, Francisca; Frayer, David T.; Law, David; Malkan, Matthew A.; Marshall, Jason; Mazzarella, Joseph M.; Murphy, Eric J.; Sanders, David; Surace, Jason "GOALS-JWST: Revealing the Buried Star Clusters in the Luminous Infrared Galaxy VV 114," *The Astrophysical Journal Letters*, Volume 944, Issue 2, id.L55, 9 pp, 2023.
- Linville, Dylan J.; Luisi, Matteo; Anderson, L. D.; Liu, Bin; Bania, T. M.; Balsler, Dana S.; Wenger, Trey V.; Haffner, L. M.; Mascoop, J. L. "The GBT Diffuse Ionized Gas Survey (GDIGS): Discrete Sources," *The Astrophysical Journal*, 959, 110, 2023.
- Liodakis, I.; Koljonen, K. I. I.; Blinov, D.; Lindfors, E.; Alexander, K. D.; Hovatta, T.; Berton, M.; Hajela, A.; Jormanainen, J.; Kouroumpatzakis, K.; Mandarakas, N.; Nilsson, K. "Optical polarization from colliding stellar stream shocks in a tidal disruption event," *Science*, 380, 656, 2023.
- Liszt, H.; Gerin, M. "The dark neutral medium is (mostly) molecular hydrogen," *Astronomy and Astrophysics*, 675, A145, 2023.
- Liszt, Harvey; Gerin, Maryvonne "Molecular Hydrogen and its Proxies HCO<sup>+</sup> and CO in the Diffuse Interstellar Medium," *The Astrophysical Journal*, 943, 172, 2023.
- Litke, Katrina C.; Marrone, Daniel P.; Aravena, Manuel; Archipley, Melanie; Béthermin, Matthieu; Burgoyne, James; Cathey, Jared; Chapman, Scott C.; Gonzalez, Anthony H.; Greve, Thomas R.; Gururajan, Gayathri; Hayward, Christopher C.; Malkan, Matthew A.; Phadke, Kedar A.;

- Reuter, Cassie A.; Rotermund, Kaja M.; Spilker, Justin S.; Stark, Antony A.; Sulzenauer, Nikolaus; Vieira, Joaquin D.; Vizgan, David; Weiß, Axel "The ISM in the  $z = 6.9$  Interacting Galaxies of SPT0311-58," *The Astrophysical Journal*, 949, 87, 2023.
- Liu, Daizhong; Förster Schreiber, N. M.; Genzel, R.; Lutz, D.; Price, S. H.; Lee, L. L.; Baker, Andrew J.; Burkert, A.; Coogan, R. T.; Davies, R. I.; Davies, R. L.; Herrera-Camus, R.; Kodama, Tadayuki; Lee, Minju M.; Nestor, A.; Pulsoni, C.; Renzini, A.; Sharon, Chelsea E.; Shimizu, T. T.; Tacconi, L. J.; Tadaki, Ken-Ichi; Übler, H. "An 600 pc View of the Strongly Lensed, Massive Main-sequence Galaxy J0901: A Baryon-dominated, Thick Turbulent Rotating Disk with a Clumpy Cold Gas Ring at  $z = 2.259$ ," *The Astrophysical Journal*, 942, 98, 2023.
- Liu, Daizhong; Schinnerer, Eva; Cao, Yixian; Leroy, Adam; Usero, Antonio; Rosolowsky, Erik; Kruijssen, J. M. Diederik; Chevance, Mélanie; Glover, Simon C. O.; Sormani, Mattia C.; Bolatto, Alberto D.; Sun, Jiayi; Stuber, Sophia K.; Teng, Yu-Hsuan; Bigiel, Frank; Bešlić, Ivana; Grasha, Kathryn; Henshaw, Jonathan D.; Barnes, Ashley T.; Den Brok, Jakob S.; Saito, Toshiki; Dale, Daniel A.; Watkins, Elizabeth J.; Pan, Hsi-An; Klessen, Ralf S.; Emsellem, Eric; Anand, Gagandeep S.; Deger, Sinan; Egorov, Oleg V.; Faesi, Christopher M.; Hassani, Hamid; Larson, Kirsten L.; Lee, Janice C.; Lopez, Laura A.; Pety, Jérôme; Sandstrom, Karin; Thilker, David A.; Whitmore, Bradley C.; Williams, Thomas G. "PHANGS-JWST First Results: Stellar-feedback-driven Excitation and Dissociation of Molecular Gas in the Starburst Ring of NGC 1365?," *The Astrophysical Journal*, 944, L19, 2023.
- Liu, Daizhong; Schinnerer, Eva; Saito, Toshiki; Rosolowsky, Erik; Leroy, Adam; Usero, Antonio; Sandstrom, Karin; Klessen, Ralf S.; Glover, Simon C. O.; Ao, Yiping; Bešlić, Ivana; Bigiel, Frank; Cao, Yixian; Chastenet, Jérôme; Chevance, Mélanie; Dale, Daniel A.; Gao, Yu; Hughes, Annie; Kreckel, Kathryn; Kruijssen, J. M. Diederik; Pan, Hsi-An; Pety, Jérôme; Salak, Dragan; Santoro, Francesco; Schrubba, Andreas; Sun, Jiayi; Teng, Yu-Hsuan; Williams, Thomas "C I and CO in nearby spiral galaxies. I. Line ratio and abundance variations at  $\sim 200$  pc scales," *Astronomy and Astrophysics*, 672, A36, 2023.
- Liu, Junhao; Zhang, Qizhou; Koch, Patrick M.; Liu, Haoyu Baobab; Li, Zhi-Yun; Li, Shanghuo; Girart, Josep Miquel; Chen, Hwei-Ru Vivien; Ching, Tao-Chung; Ho, Paul T. P.; Lai, Shih-Ping; Qiu, Keping; Rao, Ramprasad; Tang, Ya-Wen "Multi-scale Physical Properties of NGC 6334 as Revealed by Local Relative Orientations between Magnetic Fields, Density Gradients, Velocity Gradients, and Gravity," *The Astrophysical Journal*, 945, 160, 2023.
- Liu, Junhao; Zhang, Qizhou; Liu, Haoyu Baobab; Qiu, Keping; Li, Shanghuo; Li, Zhi-Yun; Ho, Paul T. P.; Girart, Josep Miquel; Ching, Tao-Chung; Chen, Hwei-Ru Vivien; Lai, Shih-Ping; Rao, Ramprasad; Tang, Ya-Wen "Deviation from a Continuous and Universal Turbulence Cascade in NGC 6334 due to Massive Star Formation Activity," *The Astrophysical Journal*, 949, 30, 2023.
- Liu, Jun-Ting; Chen, Xi; Chen, Xiao-Dian; Chen, Zhi-Wei; Song, Shi-Min; Wang, You-Xin; Zhang, Yan-Kun; Zhao, Zhang; Li, Bin; Xia, Bo; Shen, Zhi-Qiang "Luminosity Outburst of a High-mass Young Stellar Object Triggered by the Surrounding Radiation Field," *The Astrophysical Journal*, 951, L24, 2023.
- Liu, Mingrui; Hu, Yue; Lazarian, A.; Xu, Siyao; Soida, Marian "Multiphase magnetic fields in the galaxy NGC 3627," *Monthly Notices of the Royal Astronomical Society*, 519, 1068, 2023.
- Liu, N.; Zhu, Z.; Antoniadis, J.; Liu, J.-C.; Zhang, H. "Systematics of planetary ephemeris reference frames inferred from pulsar timing astrometry," *Astronomy and Astrophysics*, 674, A187, 2023.
- Liu, Siqi; Luo, A. -Li; Zhang, Wei; Zhang, Yan-Xia; Kong, Xiao; Zhao, Yong-Heng "The H I Gas Fraction Scaling Relation of the Green Pea Galaxies," *Research in Astronomy and Astrophysics*, 23, 65006, 2023.
- Liu, Tingting; Cohen, Tyler; Mcgrath, Casey; Demorest, Paul B.; Vigeland, Sarah J. "Multi-messenger Approaches to Supermassive Black Hole Binary Detection and Parameter Estimation. II. Optimal Strategies for a Pulsar Timing Array," *The Astrophysical Journal*, 945, 78, 2023.
- Lockman, Felix J.; Benjamin, Robert A.; Pichette, Nicolas; Thibodeau, Christopher "A Component of the Smith High-velocity Cloud Now Crossing the Galactic Plane," *The Astrophysical Journal*, 943, 55, 2023.
- Long, Feng; Ren, Bin B.; Wallack, Nicole L.; Harsono, Daniel; Herczeg, Gregory J.; Pinilla, Paola; Mawet, Dimitri; Liu, Michael C.; Andrews, Sean M.; Bai, Xue-Ning; Cabrit, Sylvie; Cieza, Lucas A.; Johnstone, Doug; Leisenring, Jarron M.; Lodato, Giuseppe; Liu, Yao; Manara, Carlo F.; Mulders, Gijs D.; Ragusa, Enrico; Sallum, Steph; Shi, Yangfan; Tazzari, Marco; Uyama, Taichi; Wagner, Kevin; Wilner, David J.; Xuan, Jerry W. "A Large Double-ring Disk Around the Taurus M Dwarf J04124068+2438157," *The Astrophysical Journal*, 949, 27, 2023.
- Loni, Alessandro; Serra, Paolo; Sarzi, Marc; Józsa, Gyula I. G.; Anta, Pablo M. Galán-De; Zabel, Nikki; Kleiner, Dane; Maccagni, Filippo M.; Molnár, Daniel; Ramatsoku, Mpati; Loi, Francesca; Corsini, Enrico M.; Pisano, D. J.; Kamphuis, Peter; Davis, Timothy A.; De Blok, W. J. G.; Dettmar, Ralf J.; Falcon-Barroso, Jesus; Iodice, Enrichetta; Lara-López, Maritza A.; Loubser, S. Ilani; Morokuma-Matsui, Kana; Peletier, Reynier; Pinna, Francesca; Poci, Adriano; Smith, Matthew W. L.; Trager, Scott C.; Van De Ven, Glenn "NGC 1436: the making of a lenticular galaxy in the Fornax Cluster," *Monthly Notices of the Royal Astronomical Society*, 523, 1140, 2023.
- Lopez, Sebastian; Lopez, Laura A.; Nguyen, Dustin D.; Thompson, Todd A.; Mathur, Smita; Bolatto, Alberto D.; Vulic, Neven; Sardone, Amy "X-Ray Properties of NGC 253's Starburst-driven Outflow," *The Astrophysical Journal*, 942, 108, 2023.
- Lopez-Rodriguez, Enrique "The Magnetic Fields of Starburst Galaxies. I. Identification and Characterization of the Thermal Polarization in the Galactic Disk and Outflow," *The Astrophysical Journal*, 953, 113, 2023.
- Lopez-Rodriguez, Enrique; Borlaff, Alejandro S.; Beck, Rainer; Reach, William T.; Mao, Sui Ann; Ntormousi, Evangelia; Tassis, Konstantinos; Martin-Alvarez, Sergio; Clark, Susan E.; Dale, Daniel A.; Del Moral-Castro, Ignacio "Extragalactic Magnetism with SOFIA (SALSA Legacy Program): The Magnetic Fields in the Multiphase Interstellar Medium of the Antennae Galaxies," *The Astrophysical Journal*, 942, L13, 2023.
- Lu, Chang-Zhi; Zhang, Tingting; Zhang, Tong-Jie "Statistical distribution of HI 21cm intervening absorbers as potential cosmic acceleration probes," *Monthly Notices of the Royal Astronomical Society*, 521, 3150, 2023.
- Lu, Ru-Sen; Asada, Keiichi; Krichbaum, Thomas P.; Park, Jongho; Tazaki, Fumie; Pu, Hung-Yi; Nakamura, Masanori; Lobanov, Andrei; Hada, Kazuhiro; Akiyama, Kazunori; Kim, Jae-Young; Martí-Vidal, Ivan; Gómez, José L.; Kawashima, Tomohisa; Yuan, Feng; Ros, Eduardo; Alef, Walter; Britzen, Silke; Bremer, Michael; Broderick, Avery E.; Doi, Akihiro; Giovannini, Gabriele; Giroletti, Marcello; Ho, Paul T. P.; Honma, Mareki; Hughes, David H.; Inoue, Makoto; Jiang, Wu; Kino, Motoki; Koyama, Shoko; Lindqvist, Michael; Liu, Jun; Marscher, Alan P.; Matsushita, Satoki; Nagai, Hiroshi; Rottmann, Helge; Savolainen, Tuomas; Schuster, Karl-Friedrich; Shen, Zhi-Qiang; De Vicente, Pablo; Walker, R. Craig; Yang, Hai; Zensus, J. Anton; Algaba, Juan Carlos; Allardi, Alexander; Bach, Uwe; Berthold, Ryan; Bintley, Dan; Byun, Do-Young; Casadio, Carolina; Chang, Shu-Hao; Chang, Chih-Cheng; Chang, Song-Chu; Chen, Chung-Chen; Chen, Ming-Tang; Chilson, Ryan; Chuter, Tim C.; Conway, John; Crew, Geoffrey B.; Dempsey, Jessica T.; Dornbusch, Sven; Faber, Aaron; Friberg, Per; García, Javier González; Garrido, Miguel Gómez; Han, Chih-Chiang; Han, Kuo-Chang; Hasegawa, Yutaka; Herrero-Illana, Ruben; Huang, Yau-De; Huang, Chih-Wei L.; Impellizzeri, Violette; Jiang, Homin; Jinchi, Hao; Jung, Taehyun; Kallunki, Juha; Kirves, Petri; Kimura, Kimihiro; Koay, Jun Yi; Koch, Patrick M.; Kramer, Carsten; Kraus, Alex; Kubo, Derek; Kuo, Cheng-Yu; Li, Chao-Te; Lin, Lupin Chun-Che; Liu, Ching-Tang; Liu, Kuan-Yu; Lo, Wen-Ping; Lu, Li-Ming; Macdonald, Nicholas; Martin-Cocher, Pierre; Messias, Hugo; Meyer-Zhao, Zheng; Minter, Anthony; Nair, Dhanya G.; Nishioka, Hiroaki; Norton, Timothy J.; Nystrom, George; Ogawa, Hideo; Oshiro, Peter; Patel, Nimesh A.; Pen, Ue-Li; Pidopryhora, Yurii; Pradel, Nicolas; Raffin, Philippe A.; Rao, Ramprasad; Ruiz, Ignacio; Sanchez, Salvador; Shaw, Paul; Snow, William; Sridharan, T. K.; Srinivasan, Ranjani; Tercero,

## APPENDIX A: PUBLICATIONS

- Belén; Torne, Pablo; Traianou, Efthalia; Wagner, Jan; Walther, Craig; Wei, Ta-Shun; Yang, Jun; Yu, Chen-Yu "A ring-like accretion structure in M87 connecting its black hole and jet," *Nature*, 616, 686, 2023.
- Lugger, Phyllis M.; Cohn, Haldan N.; Heinke, Craig O.; Zhao, Jiaqi; Zhao, Yue; Anderson, Jay "Exotica in the globular cluster M4, studied with Chandra, HST, and the VLA," *Monthly Notices of the Royal Astronomical Society*, 524, 2088, 2023.
- Lunz, Susanne; Anderson, James M.; Xu, Ming H.; Titov, Oleg; Heinkelmann, Robert; Johnson, Megan C.; Schuh, Harald "Enhancing the alignment of the optically bright Gaia reference frame with respect to the International Celestial Reference System," *Astronomy and Astrophysics*, 676, A11, 2023.
- Luo, Gan; Zhang, Zhi-Yu; Bisbas, Thomas G.; Li, Di; Zhou, Ping; Tang, Ningyu; Wang, Junzhi; Zuo, Pei; Yue, Nannan "Abundance Ratios of OH/CO and HCO+/CO as Probes of the Cosmic-Ray Ionization Rate in Diffuse Clouds," *The Astrophysical Journal*, 946, 91, 2023.
- Luo, Qiu-Yi; Liu, Tie; Lee, Aaron T.; Offner, Stella S. R.; Di Francesco, James; Johnstone, Doug; Juvela, Mika; Goldsmith, Paul F.; Qin, Sheng-Li; Mai, Xiaofeng; Liu, Xun-Chuan; Sanhueza, Patricio; Xu, Feng-Wei; Tatematsu, Ken'ichi; Dutta, Somnath; Chen, Hui-Ru Vivien; Li, Shanghuo; Yang, Aiyuan; Liu, Sheng-Yuan; Lee, Chin-Fei; Hirano, Naomi; Lee, Chang Won; Sahu, Dipen; Shang, Hsien; Hsu, Shih-Ying; Bronfman, Leonardo; Kwon, Woojin; Rawlings, M. G.; Eden, David; Lu, Xing; Gu, Qi-Lao; Ren, Zhiyuan; Ward-Thompson, D.; Shen, Zhi-Qiang "ALMA Survey of Orion Planck Galactic Cold Clumps (ALMASOP): A Forming Quadruple System with Continuum Ribbons" and Intricate Outflows," *The Astrophysical Journal*, 952, L2, 2023.
- Luque-Escamilla, Pedro L.; Martí, Josep; Mestre, Enrique; Combi, Jorge A.; Albacete-Colombo, Juan F. "A blazar candidate for the Fermi source 4FGL J1848.7-0129," *Monthly Notices of the Royal Astronomical Society*, 518, 3017, 2023.
- Lyu, Fen; Liang, En-Wei "Comparison of burst properties between FRB 20190520B and FRB 20121102A," *Monthly Notices of the Royal Astronomical Society*, 522, 5600, 2023.
- Ma, Peter Xiangyuan; Ng, Cherry; Rizk, Leandro; Croft, Steve; Siemion, Andrew P. V.; Brzycki, Bryan; Czech, Daniel; Drew, Jamie; Gajjar, Vishal; Hoang, John; Isaacson, Howard; Lebofsky, Matt; Macmahon, David H. E.; De Pater, Imke; Price, Danny C.; Sheikh, Sofia Z.; Worden, S. Pete "A deep-learning search for technosignatures from 820 nearby stars," *Nature Astronomy*, 7, 492, 2023.
- Macleod, G. C.; Smits, D. P.; Hunter, T. R.; Brogan, C.; Chibueze, J. O.; Van Den Heever, S. P. "Identifying Zeeman pairs of hydroxyl masers in NGC 6334-MM3 via velocity drift," *Monthly Notices of the Royal Astronomical Society*, 520, 5464, 2023.
- Maeda, Fumiya; Egusa, Fumi; Ohta, Kouji; Fujimoto, Yusuke; Habe, Asao "Statistical Study of the Star Formation Efficiency in Bars: Is Star Formation Suppressed in Gas-rich Bars?," *The Astrophysical Journal*, 943, 7, 2023.
- Maeda, Keiichi; Chandra, Poonam; Moriya, Takashi J.; Reguitti, Andrea; Ryder, Stuart; Matsuoka, Tomoki; Michiyama, Tomonari; Pignata, Giuliano; Hiramatsu, Daichi; Bostroem, K. Azalee; Kundu, Esha; Kuncarayakti, Hanindyo; Bersten, Melina C.; Pooley, David; Lee, Shiu-Hang; Patnaude, Daniel; Rodríguez, Ósmar; Folatelli, Gaston "A Multiwavelength View of the Rapidly Evolving SN 2018ivc: An Analog of SN IIb 1993J but Powered Primarily by Circumstellar Interaction," *The Astrophysical Journal*, 942, 17, 2023.
- Maeda, Keiichi; Michiyama, Tomonari; Chandra, Poonam; Ryder, Stuart; Kuncarayakti, Hanindyo; Hiramatsu, Daichi; Imanishi, Masatoshi "Resurrection of Type IIIc Supernova 2018ivc: Implications for a Binary Evolution Sequence Connecting Hydrogen-rich and Hydrogen-poor Progenitors," *The Astrophysical Journal*, 945, L3, 2023.
- Mahatma, V. H.; Basu, A.; Hardcastle, M. J.; Morabito, L. K.; Van Weeren, R. J. "A low frequency sub-arcsecond view of powerful radio galaxies in rich-cluster environments: 3C 34 and 3C 320," *Monthly Notices of the Royal Astronomical Society*, 520, 4427, 2023.
- Mai, Xiaofeng; Zhang, Bo; Reid, M. J.; Moscadelli, L.; Xu, Shuangjing; Sun, Yan; Zhang, Jingdong; Chen, Wen; Wen, Shiming; Luo, Qiuyi; Menten, Karl M.; Zheng, Xingwu; Brunthaler, Andreas; Xu, Ye; Wang, Guangli "The Parallax and 3D Kinematics of Water Masers in the Massive Star-forming Region G034.43+0.24," *The Astrophysical Journal*, 949, 10, 2023.
- Maity, A. K.; Dewangan, L. K.; Bhadari, N. K.; Ojha, D. K.; Chen, Z.; Pandey, Rakesh "AFGL 5180 and AFGL 6366S: sites of hub-filament systems at the opposite edges of a filamentary cloud," *Monthly Notices of the Royal Astronomical Society*, 523, 5388, 2023.
- Makrygianni, Lydia; Trakhtenbrot, Benny; Arcavi, Iair; Ricci, Claudio; Lam, Marco C.; Horesh, Assaf; Sfaradi, Itai; Bostroem, K. Azalee; Hosseinzadeh, Griffin; Howell, D. Andrew; Pellegrino, Craig; Fender, Rob; Green, David A.; Williams, David R. A.; Bright, Joe "AT 2021l0i: A Bowen Fluorescence Flare with a Rebrightening Episode Occurring in a Previously Known AGN," *The Astrophysical Journal*, 953, 32, 2023.
- Malizia, A.; Bassani, L.; Landi, R.; Molina, M.; Masetti, N.; Palazzi, E.; Bruni, G.; Bazzano, A.; Ubertini, P.; Bird, A. J. "Update of the INTEGRAL/IBIS active galactic nuclei catalogue: Deeper on the Galactic plane and wider beyond," *Astronomy and Astrophysics*, 671, A152, 2023.
- Mallick, Kshitiz K.; Dewangan, Lokesh K.; Ojha, Devendra K.; Baug, Tapas; Zinchenko, Igor I. "Structure and Kinematics of Sh2-138-A Distant Hub-filament System in the Outer Galactic Plane," *The Astrophysical Journal*, 944, 228, 2023.
- Manna, Arijit; Pal, Sabyasachi "ACA observation and chemical modeling of phosphorus nitride towards hot molecular cores G10.47+ 0.03 and G31.41+ 0.31," *Journal of Astrophysics and Astronomy*, 45, 3, 2023.
- Manna, Arijit; Pal, Sabyasachi "Identification of interstellar cyanamide towards the hot molecular core G358.93-0.03 MM1," *Astrophysics and Space Science*, 368, 33, 2023.
- Manna, Arijit; Pal, Sabyasachi "Detection of complex nitrogen-bearing molecule ethyl cyanide towards the hot molecular core G10.47 + 0.03," *Astrophysics and Space Science*, 368, 44, 2023.
- Manna, Arijit; Pal, Sabyasachi "Detection of monothioformic acid towards the solar-type protostar IRAS 16293-2422," *Journal of Astrophysics and Astronomy*, 44, 69, 2023.
- Manna, Arijit; Pal, Sabyasachi; Viti, Serena; Sinha, Sekhar "Identification of the simplest sugar-like molecule glycolaldehyde towards the hot molecular core G358.93-0.03 MM1," *Monthly Notices of the Royal Astronomical Society*, 525, 2229, 2023.
- Manna, Souvik; Roy, Subhashis "Magnetic Fields, Star Formation Rates, and Gas Densities at Sub-kiloparsec Scales in a Pilot Sample of Nearby Galaxies," *The Astrophysical Journal*, 944, 86, 2023.
- Marchal, Antoine; Martin, Peter G. "On the Origin of the North Celestial Pole Loop," *The Astrophysical Journal*, 942, 70, 2023.
- Marchesini, E. J.; Reynaldi, V.; Vieyro, F.; Saponara, J.; Andruchow, I.; López, I. E.; Benaglia, P.; Cellone, S. A.; Masetti, N.; Massaro, F.; Peña-Herazo, H. A.; Chavushyan, V.; Combi, J. A.; Acosta-Pulido, J. A.; Agís González, B.; Castro-Segura, N. "Disentangling the nature of the prototype radio weak BL Lac. Contemporaneous multifrequency observations of WISE J141046.00+740511.2," *Astronomy and Astrophysics*, 670, A91, 2023.
- Margot, Jean-Luc; Li, Megan G.; Pinchuk, Pavlo; Myhrvold, Nathan; Lesyna, Larry; Alcantara, Lea E.; Andraikin, Megan T.; Arunseangroj, Jeth; Baclet, Damien S.; Belk, Madison H.; Bhadha, Zerxes R.; Brandis, Nicholas W.; Carey, Robert E.; Cassar, Harrison P.; Chava, Sai S.; Chen, Calvin; Chen, James; Cheng, Kellen T.; Cimbri, Alessia; Cloutier, Benjamin; Combitsis, Jordan A.; Couvrette, Kelly L.; Coy, Brandon P.; Davis, Kyle W.; Delcayre, Antoine F.; Du, Michelle R.; Feil, Sarah E.; Fu, Danning; Gilmore, Travis J.; Grahill-Bland, Emery; Iglesias, Laura M.; Juneau, Zoe; Karapetian, Anthony G.; Karfakis, George; Lambert, Christopher T.; Lazbin, Eric A.; Li, Jian H.; Li, Zhuofu (Chester); Liskij, Nicholas M.; Lopilato, Anthony V.; Lu, Darren J.; Ma, Detao; Mathur, Vedant; Minasyan, Mary H.; Muller, Maxwell K.; Nasielski, Mark T.; Nguyen, Janice T.; Nicholson, Lorraine M.; Niemoeller, Samantha; Ohri, Divij; Padhye, Atharva U.; Penmetcha, Supreethi V.; Prakash, Yugantar; Qi, Xinyi (Cindy); Rindt, Liam; Sahu,

- Vedant; Scally, Joshua A.; Scott, Zefyr; Seddon, Trevor J.; Shohet, Lara-Lynn V.; Sinha, Anchal; Sinigiani, Anthony E.; Song, Jiuxu; Stice, Spencer M.; Tabucol, Nadine M.; Uplisashvili, Andria; Vanga, Krishna; Vazquez, Amaury G.; Vetushko, George; Villa, Valeria; Vincent, Maria; Waasdorp, Ian J.; Wagaman, Ian B.; Wang, Amanda; Wight, Jade C.; Wong, Ella; Yamaguchi, Natsuko; Zhang, Zijin; Zhao, Junyang; Lynch, Ryan S. "A Search for Technosignatures Around 11,680 Stars with the Green Bank Telescope at 1.15-1.73 GHz," *The Astronomical Journal*, 166, 206, 2023.
- Margutti, Raffaella; Bright, J. S.; Matthews, D. J.; Coppejans, D. L.; Alexander, K. D.; Berger, E.; Bietenholz, M.; Chornock, R.; Demarchi, L.; Drout, M. R.; Eftekhari, T.; Jacobson-Galán, W. V.; Laskar, T.; Milisavljevic, D.; Murase, K.; Nicholl, M.; Omand, C. M. B.; Stroh, M.; Terreran, G.; Vanderley, B. A. "Luminous Radio Emission from the Superluminous Supernova 2017ens at 3.3 yr after Explosion," *The Astrophysical Journal*, 954, L45, 2023.
- Marin, Frédéric; Barnouin, Thibault; Ehler, Steven R.; Peirson, Abel Lawrence; Lopez-Rodriguez, Enrique; Petropoulou, Maria; Wu, Kinwah; Martí-Vidal, Iván "An X-rays-to-radio investigation of the nuclear polarization from the radio-galaxy Centaurus A," *Monthly Notices of the Royal Astronomical Society*, 526, 6321, 2023.
- Marinelli, A. D.; Ortega, M. E.; Paron, S.; Isequilla, N. "Study of the internal structure of the molecular clump AGAL G20.746-00.092," *Boletín de la Asociación Argentina de Astronomía La Plata Argentina*, 64, 118, 2023.
- Marshall, Jonathan P.; Ertel, Steve; Birtcil, Eric; Villaver, Eva; Kemper, Francisca; Boffin, Henri; Scicluna, Peter; Kamath, Devika "Evidence for the Disruption of a Planetary System During the Formation of the Helix Nebula," *The Astronomical Journal*, 165, 22, 2023.
- Marshall, Jonathan P.; Milli, J.; Choquet, E.; Del Burgo, C.; Kennedy, G. M.; Kemper, F.; Wyatt, M. C.; Kral, Q.; Soummer, R. "Stirred but not shaken: a multiwavelength view of HD 16743's debris disc," *Monthly Notices of the Royal Astronomical Society*, 521, 5940, 2023.
- Martínez-Henares, Antonio; Jiménez-Serra, Izaskun; Martín-Pintado, Jesús; Huélam, Nuria; Prasad, Sirina; Zhang, Qizhou; Moran, James; Cao, Yue; Báez-Rubio, Alejandro "Modeling of the High-velocity Jet Powered by the Massive Star MWC 349A," *The Astrophysical Journal*, 955, 119, 2023.
- Martínez-Lombilla, Cristina; Infante-Sainz, Raúl; Jiménez-Ibarra, Felipe; Knapen, Johan H.; Trujillo, Ignacio; Comerón, Sébastien; Borlaff, Alejandro S.; Román, Javier "The truncation of the disk of NGC 4565. Detected up to  $z = 4$  kpc, with star formation, and affected by the warp," *Astronomy and Astrophysics*, 678, A62, 2023.
- Massalkhi, S.; Jiménez-Serra, I.; Martín-Pintado, J.; Rivilla, V. M.; Colzi, L.; Zeng, S.; Martín, S.; Tercero, B.; De Vicente, P.; Requena-Torres, M. A. "The first detection of SiC2 in the interstellar medium," *Astronomy and Astrophysics*, 678, A45, 2023.
- Massaro, F.; White, S. V.; García-Pérez, A.; Jimenez-Gallardo, A.; Capetti, A.; Cheung, C. C.; Forman, W. R.; Mazzucchelli, C.; Paggi, A.; Nesvadba, N. P. H.; Madrid, J. P.; Andruchow, I.; Cellone, S.; Peña-Herazo, H. A.; Grosseová, R.; Balmaverde, B.; Sani, E.; Chavushyan, V.; Kraft, R. P.; Reynaldi, V.; Leto, C. "Powerful Radio Sources in the Southern Sky. I. Optical Identifications," *The Astrophysical Journal Supplement Series*, 265, 32, 2023.
- Massi, F.; Caratti O Garatti, A.; Cesaroni, R.; Sridharan, T. K.; Ghose, E.; Pinna, E.; Beltrán, M. T.; Leurini, S.; Moscadelli, L.; Sanna, A.; Agapito, G.; Briguglio, R.; Christou, J.; Esposito, S.; Mazzoni, T.; Miller, D.; Plantet, C.; Power, J.; Puglisi, A.; Rossi, F.; Rothberg, B.; Taylor, G.; Veillet, C. "The SOUL view of IRAS 20126+4104. Kinematics and variability of the H2 jet from a massive protostar," *Astronomy and Astrophysics*, 672, A113, 2023.
- Matković, F.; Brajša, R.; Temmer, M.; Heinemann, S. G.; Ludwig, H.-G.; Saar, S. H.; Selhorst, C. L.; Skokić, I.; Sudar, D. "Differences in physical properties of coronal bright points and their ALMA counterparts within and outside coronal holes," *Astronomy and Astrophysics*, 670, A146, 2023.
- Matthews, L. D.; Evans, N. R.; Rupen, M. P. "First Detection of Radio Emission Associated with a Classical Cepheid," *The Astronomical Journal*, 165, 92, 2023.
- Maucó, K.; Manara, C. F.; Ansdell, M.; Bettoni, G.; Claes, R.; Alcalá, J.; Miotello, A.; Facchini, S.; Haworth, T. J.; Lodato, G.; Williams, J. P. "Testing external photoevaporation in the  $\alpha$ -Orionis cluster with spectroscopy and disk mass measurements," *Astronomy and Astrophysics*, 679, A82, 2023.
- Maud, Luke T.; Asaki, Yoshiharu; Nagai, Hiroshi; Tsukui, Takafumi; Hirota, Akihiko; Fomalont, Edward B.; Dent, William R. F.; Takahashi, Satoko; Phillips, Neil "ALMA High-frequency Long-baseline Campaign in 2019: Band 9 and 10 In-band and Band-to-band Observations Using ALMA's Longest Baselines," *The Astrophysical Journal Supplement Series*, 267, 24, 2023.
- Mayker Chen, Ness; Leroy, Adam K.; Lopez, Laura A.; Benincasa, Samantha; Chevance, Mélanie; Glover, Simon C. O.; Hughes, Annie; Kreckel, Kathryn; Sarbadhicary, Sumit; Sun, Jiayi; Thompson, Todd A.; Utomo, Dyas; Bigiel, Frank; Blanc, Guillermo A.; Dale, Daniel A.; Grasha, Kathryn; Kruijssen, J. M. Diederik; Pan, Hsi-An; Querejeta, Miguel; Schinnerer, Eva; Watkins, Elizabeth J.; Williams, Thomas G. "Comparing the Locations of Supernovae to CO (2-1) Emission in Their Host Galaxies," *The Astrophysical Journal*, 944, 110, 2023.
- Mayya, Y. D.; Alzate, J. A.; Lomelí-Núñez, L.; Zaragoza-Cardiel, J.; Gómez-González, V. M. A.; Silich, S.; Fernández-Arenas, D.; Vega, O.; Ovando, P. A.; Rodríguez, L. H.; Rosa-González, D.; Luna, A.; Zamora-Avilés, M.; Rosales-Ortega, F. "The stellar population responsible for a kiloparsec-size superbubble seen in the JWST 'phantom' images of NGC 628," *Monthly Notices of the Royal Astronomical Society*, 521, 5492, 2023.
- Mazzei, Renato; Li, Zhi-Yun; Chen, Che-Yu; Fissel, Laura; Chen, Mike; Park, James "Relative alignment between magnetic fields and molecular gas structure in molecular clouds," *Monthly Notices of the Royal Astronomical Society*, 521, 3830, 2023.
- Mccarthy, T. P.; Breen, S. L.; Kaczmarek, J. F.; Chen, X.; Parfenov, S.; Sobolev, A. M.; Ellingsen, S. P.; Burns, R. A.; Macleod, G. C.; Sugiyama, K.; Brierley, A. L.; Van Den Heever, S. P. "Ammonia masers towards G 358.931-0.030," *Monthly Notices of the Royal Astronomical Society*, 522, 4728, 2023.
- McClure, M. K.; Rocha, W. R. M.; Pontoppidan, K. M.; Crouzet, N.; Chu, L. E. U.; Dartois, E.; Lamberts, T.; Noble, J. A.; Pendleton, Y. J.; Perotti, G.; Qasim, D.; Rachid, M. G.; Smith, Z. L.; Sun, Fengwu; Beck, Tracy L.; Boogert, A. C. A.; Brown, W. A.; Caselli, P.; Charnley, S. B.; Cuppen, Herma M.; Dickinson, H.; Drozdovskaya, M. N.; Egami, E.; Erkal, J.; Fraser, H.; Garrod, R. T.; Harsono, D.; Ioppolo, S.; Jiménez-Serra, I.; Jin, M.; Jørgensen, J. K.; Kristensen, L. E.; Lis, D. C.; Mccoustra, M. R. S.; Mcguire, Brett A.; Melnick, G. J.; Öberg, Karin I.; Palumbo, M. E.; Shimonishi, T.; Sturm, J. A.; Van Dishoeck, E. F.; Linnartz, H. "An Ice Age JWST inventory of dense molecular cloud ices," *Nature Astronomy*, vol 7, 431, 2023.
- Mckay, S. J.; Barger, A. J.; Cowie, L. L.; Bauer, F. E.; Rosenthal, M. J. Nicandro "Dust Properties of 870  $\mu$ m-selected Galaxies in GOODS-S," *The Astrophysical Journal*, 951, 48, 2023.
- Mckinney, Jed; Manning, Sinclair M.; Cooper, Olivia R.; Long, Arianna S.; Akins, Hollis; Casey, Caitlin M.; Faisst, Andreas L.; Franco, Maximilien; Hayward, Christopher C.; Lambrides, Erini; Magdis, Georgios; Whitaker, Katherine E.; Yun, Min; Champagne, Jaclyn B.; Drakos, Nicole E.; Gentile, Fabrizio; Gillman, Steven; Gozaliasi, Ghassem; Ilbert, Olivier; Jin, Shuowen; Koekemoer, Anton M.; Kokorev, Vasily; Liu, Daizhong; Rich, R. Michael; Robertson, Brant E.; Valentino, Francesco; Weaver, John R.; Zavala, Jorge A.; Allen, Natalie; Kartaltepe, Jeyhan S.; Mccracken, Henry Joy; Paquereau, Louise; Rhodes, Jason; Shuntov, Marko; Toft, Sune "A Near-infrared-faint, Far-infrared-luminous Dusty Galaxy at  $z \sim 5$  in COSMOS-Web," *The Astrophysical Journal*, 956, 72, 2023.
- Mckinney, Jed; Pope, Alexandra; Kirkpatrick, Allison; Armus, Lee; Díaz-Santos, Tanio; Gómez-Guijarro, Carlos; Franco, Maximilien; Elbaz,

## APPENDIX A: PUBLICATIONS

- David; Hayward, Christopher C.; Inami, Hanae; Popping, Gergö; Xiao, Mengyuan "The IR Compactness of Dusty Galaxies Sets Star Formation and Dust Properties at  $z \sim 0-2$ ," *The Astrophysical Journal*, 955, 136, 2023.
- Meidt, Sharon E.; Rosolowsky, Erik; Sun, Jiayi; Koch, Eric W.; Klessen, Ralf S.; Leroy, Adam K.; Schinnerer, Eva; Barnes, Ashley T.; Glover, Simon C. O.; Lee, Janice C.; Van Der Wel, Arjen; Watkins, Elizabeth J.; Williams, Thomas G.; Bigiel, F.; Boquien, Médéric; Blanc, Guillermo A.; Cao, Yixian; Chevance, Mélanie; Dale, Daniel A.; Egorov, Oleg V.; Emsellem, Eric; Grasha, Kathryn; Henshaw, Jonathan D.; Kruijssen, J. M. Diederik; Larson, Kirsten L.; Liu, Daizhong; Murphy, Eric J.; Pety, Jérôme; Querejeta, Miguel; Saito, Toshiki; Sandstrom, Karin M.; Smith, Rowan J.; Sormani, Mattia C.; Thilker, David A. "PHANGS-JWST First Results: Interstellar Medium Structure on the Turbulent Jeans Scale in Four Disk Galaxies Observed by JWST and the Atacama Large Millimeter/submillimeter Array," *The Astrophysical Journal*, 944, L18, 2023.
- Mendoza-Torres, J. E.; Juárez-Gama, M.; Rodríguez-Esnard, I. T. "Global kinematics study of OH masers in W49N," *Astronomy and Astrophysics*, 669, A100, 2023.
- Mercimek, S.; Podio, L.; Codella, C.; Chahine, L.; López-Sepulcre, A.; Ohashi, S.; Loinard, L.; Johnstone, D.; Menard, F.; Cuello, N.; Caselli, P.; Zamponi, J.; Aikawa, Y.; Bianchi, E.; Busquet, G.; Pineda, J. E.; Bouvier, M.; De Simone, M.; Zhang, Y.; Sakai, N.; Chandler, C. J.; Ceccarelli, C.; Alves, F.; Durán, A.; Fedele, D.; Murillo, N.; Jiménez-Serra, I.; Yamamoto, S. "FAUST VIII. The protostellar disk of VLA 1623-2417 W and its streamers imaged by ALMA," *Monthly Notices of the Royal Astronomical Society*, 522, 2384, 2023.
- Merckx, Y.; Correa, P.; De Vries, K. D.; Kotera, K.; Privon, G. C.; Van Eijndhoven, N. "Investigating starburst-driven neutrino emission from galaxies in the Great Observatories All-Sky LIRG Survey," *Physical Review D*, 108, 23015, 2023.
- Meyer, Eileen T.; Shaik, Aamil; Tang, Yanbo; Reid, Nancy; Reddy, Karthik; Breiding, Peter; Georgopoulos, Markos; Chiaberge, Marco; Perlmán, Eric; Clautice, Devon; Sparks, William; Denigris, Nat; Trevor, Max "Variability of extragalactic X-ray jets on kiloparsec scales," *Nature Astronomy*, vol 7, 967, 2023.
- Meyer, Romain A.; Neeleman, Marcel; Walter, Fabian; Venemans, Bram "ALMA 300 pc Resolution Imaging of a  $z = 6.79$  Quasar: No Evidence for Supermassive Black Hole Influence on the C II Kinematics," *The Astrophysical Journal*, 956, 127, 2023.
- Miao, Chen-Chen; Blackmon, Victoria; Zhu, Wei-Wei; Li, Dong-Zi; Ge, Ming-Yu; You, Xiao-Peng; Mclaughlin, Maura; Li, Di; Wang, Na; Wang, Pei; Niu, Jia-Rui; Cruces, M.; Yuan, Jian-Ping; Bai, Jun-Tao; Champion, D. J.; Chen, Yu-Tong; Chi, Ming-Min; Freire, P. C. C.; Feng, Yi; Gan, Zhen-Ye; Kramer, M.; Kou, Fei-Fei; Li, Yu-Xi; Miao, Xue-Li; Meng, Ling-Qi; Niu, Chen-Hui; Sun, Sheng-Nan; Sun, Zhong-Yi; Tedila, H. M.; Wang, Shuang-Qiang; Wu, Qing-Dong; Wang, Jing-Bo; Wen, Zhi-Gang; Wang, Shen; Wang, Ya-Biao; Wang, Cheng-Jie; Xue, Meng-Yao; Yue, You-Ling; Yuan, Mao; Yao, Ju-Mei; Yan, Wen-Ming; Zhao, Ru-Shuang; Zhang, Lei; Zhao, De "Reciprocating Magnetic Fields in the Pulsar Wind Observed from the Black Widow Pulsar J1720-0534," *Research in Astronomy and Astrophysics*, 23, 105005, 2023.
- Michail, Joseph M.; Yusef-Zadeh, Farhad; Wardle, Mark; Kunneriath, Devaky "Polarized signatures of adiabatically expanding hotspots in Sgr A\*'s accretion flow," *Monthly Notices of the Royal Astronomical Society*, 520, 2644, 2023.
- Michel, Arnaud; Sadavoy, Sarah I.; Sheehan, Patrick D.; Looney, Leslie W.; Cox, Erin G.; Tobin, John J.; Van Der Marel, Nienke; Segura-Cox, Dominique M. "Finding Substructures in Protostellar Disks in Ophiuchus," *The Astronomical Journal*, 166, 184, 2023.
- Michiyama, Tomonari; Inoue, Yoshiyuki; Doi, Akihiro "The centimeter-to-submillimeter broad-band radio spectrum of the central compact component in a nearby type-II Seyfert galaxy NGC 1068," *Publications of the Astronomical Society of Japan*, 75, 874, 2023.
- Middei, Riccardo; Liodakis, Ioannis; Perri, Matteo; Puccetti, Simonetta; Cavazzuti, Elisabetta; Di Gesu, Laura; Ehler, Steven R.; Madejski, Grzegorz; Marscher, Alan P.; Marshall, Herman L.; Muleri, Fabio; Negro, Michela; Jorstad, Svetlana G.; Agís-González, Beatriz; Agudo, Iván; Bonnoli, Giacomo; Bernardos, María I.; Casanova, Víctor; García-Comas, Maya; Husillos, César; Marchini, Alessandro; Sota, Alfredo; Kouch, Pouya M.; Lindfors, Elina; Borman, George A.; Kopatskaya, Evgenia N.; Larionova, Elena G.; Morozova, Daria A.; Savchenko, Sergey S.; Vasilyev, Andrey A.; Zhovtan, Alexey V.; Casadio, Carolina; Escudero, Juan; Myserlis, Ioannis; Hales, Antonio; Kamenó, Seiji; Kneissl, Ruediger; Messias, Hugo; Nagai, Hiroshi; Blinov, Dmitry; Bourbah, Ioakeim G.; Kiehlmann, Sebastian; Kontopodis, Evangelos; Mandarakas, Nikos; Romanopoulos, Stylianos; Skaliadis, Raphael; Vervelaki, Anna; Masiero, Joseph R.; Mawet, Dimitri; Millar-Blanchaer, Maxwell A.; Panopoulou, Georgia V.; Tinyanont, Samaporn; Berdyugin, Andrei V.; Kagitani, Masato; Kravtsov, Vadim; Sakanoi, Takeshi; Imazawa, Ryo; Sasada, Mahito; Fukazawa, Yasushi; Kawabata, Koji S.; Uemura, Makoto; Mizuno, Tsunefumi; Nakaoka, Tatsuya; Akitaya, Hiroshi; Gurwell, Mark; Rao, Ramprasad; Di Lalla, Niccolò; Cibrario, Nicolò; Donnarumma, Immacolata; Kim, Dawoon E.; Omodei, Nicola; Pacciani, Luigi; Poutanen, Juri; Tavecchio, Fabrizio; Antonelli, Lucio A.; Bachetti, Matteo; Baldini, Luca; Baumgartner, Wayne H.; Bellazzini, Ronaldo; Bianchi, Stefano; Bongiorno, Stephen D.; Bonino, Raffaella; Brez, Alessandro; Bucciantini, Niccolò; Capitanio, Fiamma; Castellano, Simone; Ciprini, Stefano; Costa, Enrico; De Rosa, Alessandra; Del Monte, Ettore; Di Marco, Alessandro; Doroshenko, Victor; Dovciak, Michal; Enoto, Teruaki; Evangelista, Yuri; Fabiani, Sergio; Ferrazzoli, Riccardo; Garcia, Javier A.; Gunji, Shuichi; Hayashida, Kiyoshi; Heyl, Jeremy; Iwakiri, Wataru; Karas, Vladimir; Kitaguchi, Takao; Kolodziejczak, Jeffery J.; Krawczynski, Henric; La Monaca, Fabio; Latronico, Luca; Maldera, Simone; Manfreda, Alberto; Marin, Frédéric; Marinucci, Andrea; Massaro, Francesco; Matt, Giorgio; Mitsuishi, Ikuyuki; Ng, C.-Y.; O'Dell, Stephen L.; Oppedisano, Chiara; Papitto, Alessandro; Pavlov, George G.; Peirson, Abel L.; Pesce-Rollins, Melissa; Petrucci, Pierre-Olivier; Pilia, Maura; Possenti, Andrea; Ramsey, Brian D.; Rankin, John; Ratheesh, Ajay; Romani, Roger W.; Sgró, Carmelo; Slane, Patrick; Soffitta, Paolo; Spandre, Gloria; Tamagawa, Toru; Taverna, Roberto; Tawara, Yuzuru; Tennant, Allyn F.; Thomas, Nicholas E.; Tombesi, Francesco; Trois, Alessio; Tsygankov, Sergey; Turolla, Roberto; Vink, Jacco; Weisskopf, Martin C.; Wu, Kinwah; Xie, Fei; Zane, Silvia "X-Ray Polarization Observations of BL Lacertae," *The Astrophysical Journal*, 942, L10, 2023.
- Mininni, C.; Beltrán, M. T.; Colzi, L.; Rivilla, V. M.; Fontani, F.; Lorenzani, A.; López-Gallifa, Á.; Viti, S.; Sánchez-Monge, Á.; Schilke, P.; Testi, L. "The GAUPO project. III. Characterization of the O- and N-bearing complex organic molecules content and search for chemical differentiation," *Astronomy and Astrophysics*, 677, A15, 2023.
- Misquitta, Persis; Eckart, Andreas; Zajaček, Michal; Yttergren, Madeleine "SDSS-FIRST-selected interacting galaxies. Optical long-slit spectroscopy study using MODS at the LBT," *Astronomy and Astrophysics*, 671, A18, 2023.
- Misra, Arpita; Jamroz, Marek; Weźgowiec, Marek "Multifrequency analysis of the radio emission from a post-merger galaxy CGCG 292-057," *Monthly Notices of the Royal Astronomical Society*, 523, 1648, 2023.
- Mitchell, Jake A. J.; Done, Chris; Ward, Martin J.; Kynoch, Daniel; Hagen, Scott; Lusso, Elisabeta; Landt, Hermine "The SOUX AGN sample: Optical/UV/X-ray SEDs and the nature of the disc," *Monthly Notices of the Royal Astronomical Society*, 524, 1796, 2023.
- Miyawaki, Ryosuke; Hayashi, Masahiko; Hasegawa, Tetsuo "An expanding ring of the hypercompact H II region W 49 N:A2," *Publications of the Astronomical Society of Japan*, 75, 225, 2023.
- Moeckel, Chris; De Pater, Imke; Deboer, David "Ammonia Abundance Derived from Juno MWR and VLA Observations of Jupiter," *The Planetary Science Journal*, 4, 25, 2023.
- Molina, Juan; Ho, Luis C.; Wang, Ran; Shangquan, Jinyi; Bauer, Franz E.; Treister, Ezequiel "Enhanced Star Formation Efficiency in the Central

- Regions of Nearby Quasar Hosts," *The Astrophysical Journal*, 944, 30, 2023.
- Möller, T.; Schilke, P.; Sánchez-Monge, Á.; Schmiedeke, A.; Meng, F. "The physical and chemical structure of Sagittarius B2. VII. Dust and ionized gas contributions to the full molecular line survey of 47 hot cores," *Astronomy and Astrophysics*, 676, A121, 2023.
- Momjian, E.; Sarma, A. P. "The Discovery of the Zeeman Effect in 38 GHz Class II Methanol Masers," *The Astrophysical Journal*, 958, 75, 2023.
- Monasterio, David; Jorquera, Sebastian; Curotto, Franco; Espinoza, Camilo; Finger, Ricardo; Bronfman, Leonardo "A Proof of Concept Balanced Mixer with the use of a Digital IF Power Combiner to Improve LO Noise Rejection," *Publications of the Astronomical Society of the Pacific*, 135, 125003, 2023.
- Mondal, Sandeep Kumar; Das, Saikat; Gupta, Nayantara "Exploring the Emission Mechanisms of Mrk 180 with Long-term X-Ray and  $\gamma$ -Ray Data," *The Astrophysical Journal*, 948, 75, 2023.
- Mondal, Suman Kumar; Iqbal, Wasim; Gorai, Prasanta; Bhat, Bratati; Wakelam, Valentine; Das, Ankan "Investigating the hot molecular core, G10.47+0.03: A pit of nitrogen-bearing complex organic molecules," *Astronomy and Astrophysics*, 669, A71, 2023.
- Mondal, Surajit; Chen, Bin; Yu, Sijie "Multifrequency Microwave Imaging of Weak Transients from the Quiet Solar Corona," *The Astrophysical Journal*, 949, 56, 2023.
- Montargès, M.; Cannon, E.; De Koter, A.; Khouri, T.; Lagadec, E.; Kervella, P.; Decin, L.; McDonald, I.; Homan, W.; Waters, L. B. F. M.; Sahai, R.; Gottlieb, C. A.; Malfait, J.; Maes, S.; Pimpanuwat, B.; Jeste, M.; Danilovich, T.; De Ceuster, F.; Van De Sande, M.; Gobrecht, D.; Wallström, S. H. J.; Wong, K. T.; El Mellah, I.; Bolte, J.; Herpin, F.; Richards, A. M. S.; Baudry, A.; Etoka, S.; Gray, M. D.; Millar, T. J.; Menten, K. M.; Müller, H. S. P.; Plane, J. M. C.; Yates, J.; Zijlstra, A. "The VLT/SPHERE view of the ATOMIUM cool evolved star sample. I. Overview: Sample characterization through polarization analysis," *Astronomy and Astrophysics*, 671, A96, 2023.
- Montoya Arroyave, I.; Ciccone, C.; Makroleivadioti, E.; Weiss, A.; Lundgren, A.; Severgnini, P.; De Breuck, C.; Baumschlager, B.; Schimek, A.; Shen, S.; Aravena, M. "A sensitive APEX and ALMA CO(1-0), CO(2-1), CO(3-2), and [C]I(1-0) spectral survey of 40 local (ultra-)luminous infrared galaxies," *Astronomy and Astrophysics*, 673, A13, 2023.
- Moraga Baez, Paula; Kastner, Joel H.; Balick, Bruce; Montez, Rodolfo; Bublitz, Jesse "Panchromatic HST/WFC3 Imaging Studies of Young, Rapidly Evolving Planetary Nebulae. II. NGC 7027," *The Astrophysical Journal*, 942, 15, 2023.
- Morgan, G. A.; Jawin, E. R.; Campbell, B. A.; Patterson, G. W.; Bramson, A. M.; Nypaver, C. A.; Stopar, J. D.; Jozwiak, L. M.; Stickle, A. M.; Bhiravarasu, S. S. "Radar Perspective of the Aristarchus Pyroclastic Deposit and Implications for Future Missions," *The Planetary Science Journal*, 4, 209, 2023.
- Morganti, Raffaella; Murthy, Suma; Guillard, Pierre; Oosterloo, Tom; Garcia-Burillo, Santiago "Young Radio Sources Expanding in Gas-Rich ISM: Using Cold Molecular Gas to Trace Their Impact," *Galaxies*, 11, 24, 2023.
- Morganti, Raffaella; Murthy, Suma; Oosterloo, Tom; Blanchard, Jay; Cook, Claire; Paragi, Zsolt; Orienti, Monica; Nagai, Hiroshi; Schulz, Robert "Cold gas in the heart of Perseus A," *Astronomy and Astrophysics*, 678, A42, 2023.
- Morii, Kaho; Sanhueza, Patricio; Nakamura, Fumitaka; Zhang, Qizhou; Sabatini, Giovanni; Beuther, Henrik; Lu, Xing; Li, Shanghuo; Garay, Guido; Jackson, James M.; Olguin, Fernando A.; Tafuya, Daniel; Tatematsu, Ken'ichi; Izumi, Natsuko; Sakai, Takeshi; Silva, Andrea "The ALMA Survey of 70  $\mu$ m Dark High-mass Clumps in Early Stages (ASHES). IX. Physical Properties and Spatial Distribution of Cores in IRDCs," *The Astrophysical Journal*, 950, 148, 2023.
- Morishima, Yuna; Sudou, Hiroshi; Yamauchi, Aya; Taniguchi, Yoshiaki; Nakai, Naomasa "High-sensitivity VLBI observations of water masers in the Seyfert galaxy NGC 1068," *Publications of the Astronomical Society of Japan*, 75, 71, 2023.
- Moscadelli, L.; Oliva, A.; Surcis, G.; Sanna, A.; Beltrán, M. T.; Kuiper, R. "The magnetic field of a magnetohydrodynamic disk wind: Water maser observations and simulations," *Astronomy and Astrophysics*, 680, A107, 2023.
- Mosenkov, Aleksandr V.; Rich, R. Michael; Fusco, Michael; Kenefick, Julia; Thilker, David; Marchuk, Alexander; Brosch, Noah; West, Michael; Gregg, Michael; Longstaff, Francis; Koch-Hansen, Andreas J.; Abdeen, Shameer; Roque, William "The haloes and environments of nearby galaxies (HERON) - III. A 45-kpc spiral structure in the GLSB galaxy UGC 4599," *Monthly Notices of the Royal Astronomical Society*, 525, 3016, 2023.
- Müller, Ancla; Frohn, Vanessa; Dirks, Lukas; Stein, Michael; Adebahr, Björn; Bomans, Dominik J.; Weis, Kerstin; Dettmar, Ralf-Jürgen "Multi-epoch variability of AT 2000ch (SN 2000ch) in NGC 3432. A radio continuum and optical study," *Astronomy and Astrophysics*, 670, A130, 2023.
- Muller, S.; Martí-Vidal, I.; Combes, F.; Gérin, M.; Beelen, A.; Horellou, C.; Guélin, M.; Aalto, S.; Black, J. H.; Van Kampen, E. "Cosmo-tomography toward PKS 1830-211: Variability of the quasar and of its foreground molecular absorption monitored with ALMA," *Astronomy and Astrophysics*, 674, A101, 2023.
- Muñoz Arancibia, A. M.; González-López, J.; Ibar, E.; Bauer, F. E.; Anguita, T.; Aravena, M.; Demarco, R.; Kneissl, R.; Koekemoer, A. M.; Troncoso-Iribarren, P.; Zitrin, A. "The ALMA Frontier Fields Survey. VI. Lensing-corrected 11 mm number counts in Abell 2744, MACSJ0416.1-2403, MACSJ1149.5+2223, Abell 370, and Abell S1063," *Astronomy and Astrophysics*, 675, A85, 2023.
- Muñoz-Romero, Carlos E.; Öberg, Karin I.; Law, Charles J.; Teague, Richard; Aikawa, Yuri; Bergner, Jennifer B.; Wilner, David J.; Huang, Jane; Guzmán, Viviana V.; Cleeves, L. Ilseadore "Cold Deuterium Fractionation in the Nearest Planet-forming Disk," *The Astrophysical Journal*, 943, 35, 2023.
- Muraoka, Kazuyuki; Konishi, Ayu; Tokuda, Kazuki; Kondo, Hiroshi; Miura, Rie E.; Tosaki, Tomoka; Onodera, Sachiko; Kuno, Nario; Kobayashi, Masato I. N.; Tsuge, Kiyosumi; Sano, Hidetoshi; Kitano, Naoya; Fujita, Shinji; Nishimura, Atsushi; Onishi, Toshikazu; Saigo, Kazuya; Yamada, Rin I.; Demachi, Fumika; Tachihara, Kengo; Fukui, Yasuo; Kawamura, Akiko; Aas Journals Data Editors "ACA CO(J = 2-1) Mapping of the Nearest Spiral Galaxy M33. I. Initial Results and Identification of Molecular Clouds," *The Astrophysical Journal*, 953, 164, 2023.
- Murase, Takeru; Handa, Toshihiro; Matsusaka, Ren; Shimajiri, Yoshito; Kobayashi, Masato I. N.; Kohno, Mikito; Nishi, Junya; Takeba, Norimi; Shibata, Yosuke "Multilognormal density structure in Cygnus-X molecular clouds: a fitting for N-PDF without power law," *Monthly Notices of the Royal Astronomical Society*, 523, 1373, 2023.
- Myers, Samuel A.; Howell, Ellen S.; Magri, Christopher; Verwack, Ronald J.; Fernández, Yanga R.; Marshall, Sean E.; Taylor, Patrick A. "Constraining the Limitations of NEATM-like Models: A Case Study with Near-Earth Asteroid (285263) 1998 QE2," *The Planetary Science Journal*, 4, 5, 2023.
- Nagy, David; Dessauges-Zavadsky, Miroslava; Messa, Matteo; Richard, Johan; Sun, Jiayi; Combes, Françoise; Eyholzer, Yannick "Resolved Kennicutt-Schmidt law in two strongly lensed star-forming galaxies at redshift 1," *Astronomy and Astrophysics*, 678, A183, 2023.
- Nakajima, Taku; Takano, Shuro; Tosaki, Tomoka; Taniguchi, Akio; Harada, Nanase; Saito, Toshiaki; Imanishi, Masatoshi; Nishimura, Yuri; Izumi, Takuma; Tamura, Yoichi; Kohno, Kotaro; Herbst, Eric "Molecular Abundance of the Circumnuclear Region Surrounding an Active Galactic Nucleus in NGC 1068 Based on an Imaging Line Survey in the 3 mm Band with ALMA," *The Astrophysical Journal*, 955, 27, 2023.
- Nandakumar, Meera; Dutta, Prasun "Large-scale turbulence cascade in the spiral galaxy NGC 6946," *Monthly Notices of the Royal Astronomical Society*, 526, 4690, 2023.
- Nandi, Payel; Stalin, C. S.; Saikia, D. J.; Muneer, S.; Mountrichas, George; Wylezalek, Dominika; Sagar, R.; Kissler-Patig, Markus "Star Formation in the Dwarf Seyfert Galaxy NGC 4395: Evidence for Both AGN and SN Feedback?," *The Astrophysical Journal*, 950, 81, 2023.

## APPENDIX A: PUBLICATIONS

- Nandi, Payel; Stalin, C. S.; Saikia, D. J.; Riffel, Rogemar A.; Manna, Arijit; Pal, Sabyasachi; Dors, O. L.; Wylezalek, Dominika; Paliya, Vaidehi S.; Saikia, Payaswini; Dabhade, Pratik; Patig, Markus-Kissler; Sagar, Ram "Evidence for Low-power Radio Jet-ISM Interaction at 10 pc in the Dwarf AGN Host NGC 4395," *The Astrophysical Journal*, 959, 116, 2023.
- Narayanan, Suchitra; Williams, Jonathan P.; Tobin, John J.; Jørgensen, Jes K.; Ohashi, Nagayoshi; Lin, Zhe-Yu Daniel; Van'T Hoff, Merel L. R.; Li, Zhi-Yun; Plunkett, Adele L.; Looney, Leslie W.; Takakuwa, Shigehisa; Yen, Hsi-Wei; Aso, Yusuke; Flores, Christian; Lee, Jeong-Eun; Lai, Shih-Ping; Kwon, Woojin; De Gregorio-Monsalvo, Itziar; Sharma, Rajeeb; Lee, Chang Won "Early Planet Formation in Embedded Disks (eDisk). X. Compact Disks, Extended Infall, and a Fossil Outburst in the Class I Oph IRS43 Binary," *The Astrophysical Journal*, 958, 20, 2023.
- Navarro-Almaida, D.; Bop, C. T.; Lique, F.; Esplugues, G.; Rodríguez-Baras, M.; Kramer, C.; Romero, C. E.; Fuente, A.; Caselli, P.; Rivière-Marichalar, P.; Kirk, J. M.; Chacón-Tanarro, A.; Roueff, E.; Mroczkowski, T.; Bhandarkar, T.; Devlin, M.; Dicker, S.; Lowe, I.; Mason, B.; Sarazin, C. L.; Sievers, J. "Linking the dust and chemical evolution: Taurus and Perseus. New collisional rates for HCN, HNC, and their C, N, and H isotopologues," *Astronomy and Astrophysics*, 670, A110, 2023.
- Nayak, Omnarayani; Green, Alex; Hirschauer, Alec S.; Indebetouw, Rémy; Meixner, Margaret; Wong, Tony; Chevance, Mélanie; De Marchi, Guido; Lebouteiller, Vianney; Lee, Min-Young; Looney, Leslie W.; Madden, Suzanne C.; Roman-Duval, Julia; Fukui, Yasuo; Hacar, Alvaro; Jameson, K. E.; Kalari, Venu; Oudshoorn, Luuk; Rubio, Mónica; Sabbì, Elena "Massive Star Formation in the Tarantula Nebula," *The Astrophysical Journal*, 944, 26, 2023.
- Nazari, Pooneh; Tabone, Benoît; Van'T Hoff, Merel L. R.; Jørgensen, Jes K.; Van Dishoeck, Ewine F. "Evidence for Ubiquitous Carbon Grain Destruction in Hot Protostellar Envelopes," *The Astrophysical Journal*, 951, L38, 2023.
- Neelaman, Marcel; Walter, Fabian; Decarli, Roberto; Drake, Alyssa B.; Eilers, Anna-Christina; Meyer, Romain A.; Venemans, Bram P. "ALMA 400 pc Imaging of a  $z = 6.5$  Massive Warped Disk Galaxy," *The Astrophysical Journal*, 958, 132, 2023.
- Negi, Vibhore; Gopal-Krishna; Joshi, Ravi; Chand, Hum; Wiita, Paul J.; Navaneeth, P. K.; Singh, Ravi S. "Intranight optical variability of blazars and radio-quiet quasars using the ZTF survey," *Monthly Notices of the Royal Astronomical Society*, 522, 5588, 2023.
- Neumann, Lukas; Gallagher, Molly J.; Bigiel, Frank; Leroy, Adam K.; Barnes, Ashley T.; Usoro, Antonio; Den Brok, Jakob S.; Belfiore, Francesco; Bešlić, Ivana; Cao, Yixian; Chevance, Mélanie; Dale, Daniel A.; Eibensteiner, Cosima; Glover, Simon C. O.; Grasha, Kathryn; Henshaw, Jonathan D.; Jiménez-Donaire, María J.; Klessen, Ralf S.; Kruijssen, J. M. Diederik; Liu, Daizhong; Meidt, Sharon; Pety, Jérôme; Puschig, Johannes; Querejeta, Miguel; Rosolowsky, Erik; Schinnerer, Eva; Schrupa, Andreas; Sormani, Mattia C.; Sun, Jiayi; Teng, Yu-Hsuan; Williams, Thomas G. "The ALMOND Survey: Molecular cloud properties and gas density tracers across 25 nearby spiral galaxies with ALMA," *Monthly Notices of the Royal Astronomical Society*, 521, 3348, 2023.
- Nhung, Pham Tuyet; Hoai, Do Thi; Darriulat, Pierre; Diep, Pham Ngoc; Ngoc, Nguyen Bich; Thai, Tran Thi; Tuan-Anh, Pham "Contributions of Rotation, Expansion and Line Broadening to the Morphology and Kinematics of the Inner CSE of Oxygen-rich AGB Star R Hya," *Research in Astronomy and Astrophysics*, 23, 15004, 2023.
- Nikoghosyan, E. H.; Azatyan, N. M.; Andreasyan, D. H.; Kaper, L.; Samsyan, A. L.; Yeghikyan, A. G.; Baghdasaryan, D. S.; Harutyunyan, N. A. "New eruptive variable(s) in the RAFGL 7009S H II region," *Monthly Notices of the Royal Astronomical Society*, 522, 2171, 2023.
- Nikonov, A. S.; Kovalev, Y. Y.; Kravchenko, E. V.; Pashchenko, I. N.; Lobanov, A. P. "Properties of the jet in M87 revealed by its helical structure imaged with the VLBA at 8 and 15 GHz," *Monthly Notices of the Royal Astronomical Society*, 526, 5949, 2023.
- Njeri, Ann; Beswick, Robert J.; Radcliffe, Jack F.; Thomson, A. P.; Wrigley, N.; Muxlow, T. W. B.; Garrett, M. A.; Deane, Roger P.; Moldon, Javier; Norris, Ray P.; Kothes, Roland "SPARCS-North Wide-field VLBI Survey: exploring the resolved  $\mu$ Jy extragalactic radio source population with EVN + e-MERLIN," *Monthly Notices of the Royal Astronomical Society*, 519, 1732, 2023.
- Nogueira, Pedro Henrique; Zurlo, Alice; Pérez, Sebastián; González-Ruilova, Camilo; Cieza, Lucas A.; Hales, Antonio; Bhowmik, Trisha; Ruiz-Rodríguez, Dary A.; Principe, David A.; Herczeg, Gregory J.; Williams, Jonathan P.; Cuadra, Jorge; Montesinos, Matías; Cuello, Nicolás; Chavan, Prachi; Casassus, Simon; Zhu, Zhaohuan; Goicovic, Felipe G. "Resolving the binary components of the outbursting protostar HBC 494 with ALMA," *Monthly Notices of the Royal Astronomical Society*, 523, 4970, 2023.
- Nony, T.; Galván-Madrid, R.; Motte, F.; Pouteau, Y.; Cunningham, N.; Louvet, F.; Stutz, A. M.; Lefloch, B.; Bontemps, S.; Brouillet, N.; Ginsburg, A.; Joncour, I.; Herpin, F.; Sanhueza, P.; Csengeri, T.; Towner, A. P. M.; Bonfand, M.; Fernández-López, M.; Baug, T.; Bronfman, L.; Busquet, G.; Di Francesco, J.; Gusdorf, A.; Lu, X.; Olguin, F.; Valeille-Manet, M.; Whitworth, A. P. "ALMA-IMF. V. Prestellar and protostellar core populations in the W43 cloud complex," *Astronomy and Astrophysics*, 674, A75, 2023.
- Noon, Karlie A.; Krumholz, Mark R.; Di Teodoro, Enrico M.; McClure-Griffiths, Naomi M.; Lockman, Felix J.; Armillotta, Lucia "Direct observations of the atomic-molecular phase transition in the Milky Way's nuclear wind," *Monthly Notices of the Royal Astronomical Society*, 524, 1258, 2023.
- Nyamai, Miriam M.; Linford, Justin D.; Allison, James R.; Chomiuk, Laura; Woudt, Patrick A.; Ribeiro, Valério A. R. M.; Sarbadhichary, Sumit K. "Synchrotron emission from double-peaked radio light curves of the symbiotic recurrent nova V3890 Sagittarii," *Monthly Notices of the Royal Astronomical Society*, 523, 1661, 2023.
- Oei, Martijn S. S. L.; Van Weeren, Reinout J.; Hardcastle, Martin J.; Vazza, Franco; Shimwell, Tim W.; Leclercq, Florent; Brüggem, Marcus; Röttgering, Huub J. A. "An intergalactic medium temperature from a giant radio galaxy," *Monthly Notices of the Royal Astronomical Society*, 518, 240, 2023.
- Ohashi, Nagayoshi; Tobin, John J.; Jørgensen, Jes K.; Takakuwa, Shigehisa; Sheehan, Patrick; Aikawa, Yuri; Li, Zhi-Yun; Looney, Leslie W.; Williams, Jonathan P.; Aso, Yusuke; Sharma, Rajeeb; Sai Insa Choi, Jinshi; Yamato, Yoshihide; Lee, Jeong-Eun; Tomida, Kengo; Yen, Hsi-Wei; Encalada, Frankie J.; Flores, Christian; Gavino, Sacha; Kido, Miyu; Han, Ilseung; Lin, Zhe-Yu Daniel; Narayanan, Suchitra; Phuong, Nguyen Thi; Santamaría-Miranda, Alejandro; Thieme, Travis J.; Van'T Hoff, Merel L. R.; De Gregorio-Monsalvo, Itziar; Koch, Patrick M.; Kwon, Woojin; Lai, Shih-Ping; Lee, Chang Won; Plunkett, Adele; Saigo, Kazuya; Hirano, Shingo; Lam, Ka Ho; Mori, Shoji "Early Planet Formation in Embedded Disks (eDisk). I. Overview of the Program and First Results," *The Astrophysical Journal*, 951, 8, 2023.
- Ohashi, Satoshi; Momose, Munetake; Kataoka, Akimasa; Higuchi, Aya E.; Tsukagoshi, Takashi; Ueda, Takahiro; Codella, Claudio; Podio, Linda; Hanawa, Tomoyuki; Sakai, Nami; Kobayashi, Hiroshi; Okuzumi, Satoshi; Tanaka, Hidekazu "Dust Enrichment and Grain Growth in a Smooth Disk around the DG Tau Protostar Revealed by ALMA Triple Bands Frequency Observations," *The Astrophysical Journal*, 954, 110, 2023.
- Ohno, Takahiro; Tokuda, Kazuki; Konishi, Ayu; Matsumoto, Takeru; Sewifo, Marta; Kondo, Hiroshi; Sano, Hidetoshi; Tsuge, Kisetsu; Zahorecz, Sarolta; Goto, Nao; Neelamkodan, Naslim; Wong, Tony; Fukushima, Hajime; Takekoshi, Tatsuya; Muraoka, Kazuyuki; Kawamura, Akiko; Tachihara, Kengo; Fukui, Yasuo; Onishi, Toshikazu "An Unbiased CO Survey Toward the Northern Region of the Small Magellanic Cloud with the Atacama Compact Array. II. CO Cloud Catalog," *The Astrophysical Journal*, 949, 63, 2023.
- Okoda, Yuki; Oya, Yoko; Francis, Logan; Johnstone, Doug; Ceccarelli, Cecilia; Codella, Claudio; Chandler, Claire J.; Sakai, Nami; Aikawa, Yuri; Alves, Felipe O.; Herbst, Eric; Maureira, María José; Bouvier, Mathilde; Caselli, Paola; Choudhury, Spandan; De Simone, Marta; Jiménez-Serra, Izaskun; Pineda, Jaime; Yamamoto, Satoshi "FAUST. VII. Detection of a



- Hot Corino in the Prototypical Warm Carbon-chain Chemistry Source IRAS 15398-3359," *The Astrophysical Journal*, 948, 127, 2023.
- Oliguin, Fernando A.; Sanhueza, Patricio; Chen, Hwei-Ru Vivien; Lu, Xing; Oya, Yoko; Zhang, Qizhou; Ginsburg, Adam; Taniguchi, Kotomi; Li, Shanghuo; Morii, Kaho; Sakai, Takeshi; Nakamura, Fumitaka "Digging into the Interior of Hot Cores with ALMA: Spiral Accretion into the High-mass Protostellar Core G336.01-0.82," *The Astrophysical Journal*, 959, L31, 2023.
- Olimi, Luca; Brand, J.; Elia, D. "Probing fragmentation with ALMA continuum and spectral line observations of the dense clumps in the  $\rho = 224^\circ$  region," *Monthly Notices of the Royal Astronomical Society*, 518, 1917, 2023.
- O'Neil, K.; Schneider, Stephen E.; Van Driel, W.; Liu, G.; Joseph, T.; Schwartz, A. C.; Butcher, Z. "Searching in H I for Massive Low Surface Brightness Galaxies: Samples from HyperLeda and the UGC," *The Astronomical Journal*, 165, 263, 2023.
- Orienti, M.; Murgia, M.; Dallacasa, D.; Migliori, G.; D'Ammando, F. "Young but fading radio sources: searching for remnants among compact steep-spectrum radio sources," *Monthly Notices of the Royal Astronomical Society*, 522, 3877, 2023.
- Orihara, Ryuta; Momose, Munetake; Muto, Takayuki; Hashimoto, Jun; Liu, Hauyu Baobab; Tsukagoshi, Takashi; Kudo, Tomoyuki; Takahashi, Sanemichi; Yang, Yi; Hasegawa, Yasuhiro; Dong, Ruobing; Konishi, Mihoko; Akiyama, Eiji "ALMA Band 6 high-resolution observations of the transitional disk around SY Chamaeleontis," *Publications of the Astronomical Society of Japan*, 75, 424, 2023.
- Ortega, M. E.; Martinez, N. C.; Paron, S.; Marinelli, A.; Isequilla, N. L. "Looking for evidence of high-mass star formation at core scale in a massive molecular clump," *Astronomy and Astrophysics*, 677, A129, 2023.
- Ortiz-León, Gisela N.; Dzib, Sergio A.; Loinard, Laurent; Gong, Yan; Pillai, Thushara; Plunkett, Adele "The distance to the Serpens South cluster from H<sub>2</sub>O masers," *Astronomy and Astrophysics*, 673, L1, 2023.
- Padmanabh, P. V.; Barr, E. D.; Sridhar, S. S.; Rugel, M. R.; Damas-Segovia, A.; Jacob, A. M.; Balakrishnan, V.; Berezina, M.; I Bernadich, M. C.; Brunthaler, A.; Champion, D. J.; Freire, P. C. C.; Khan, S.; Klöckner, H.-R.; Kramer, M.; Ma, Y. K.; Mao, S. A.; Men, Y. P.; Menten, K. M.; Sengupta, S.; Krishnan, V. Venkatraman; Wucknitz, O.; Wyrowski, F.; Bezuidenhout, M. C.; Buchner, S.; Burgay, M.; Chen, W.; Clark, C. J.; Künkel, L.; Nieder, L.; Stappers, B.; Legodi, L. S.; Nyamai, M. M. "The MPlFR-MeerKAT Galactic Plane survey I - System setup and early results," *Monthly Notices of the Royal Astronomical Society*, 524, 1291, 2023.
- Pagano, Michael; Liu, Jing; Liu, Adrian; Kern, Nicholas S.; Ewall-Wice, Aaron; Bull, Philip; Pascua, Robert; Ravanbakhsh, Siamak; Abdurashidova, Zara; Adams, Tyrone; Aguirre, James E.; Alexander, Paul; Ali, Zaki S.; Baartman, Rushelle; Balfour, Yanga; Beardsley, Adam P.; Bernardi, Gianni; Billings, Tashalee S.; Bowman, Judd D.; Bradley, Richard F.; Burba, Jacob; Carey, Steven; Carilli, Chris L.; Cheng, Carina; Deboer, David R.; Acedo, Eloy De Lera; Dexter, Matt; Dillon, Joshua S.; Eksteen, Nico; Ely, John; Fagnoni, Nicolas; Fritz, Randall; Furlanetto, Steven R.; Gale-Sides, Kingsley; Glendenning, Brian; Gorthi, Deepthi; Greig, Bradley; Grobbelaar, Jasper; Halday, Ziyaad; Hazelton, Bryna J.; Hewitt, Jacqueline N.; Hickish, Jack; Jacobs, Daniel C.; Julius, Austin; Kariseb, Maccalvin; Kerrigan, Joshua; Kittiwisit, Piyana; Kohn, Saul A.; Kolopanis, Matthew; Lanman, Adam; Plante, Paul La; Loots, Anita; Macmahon, David Harold Edward; Malan, Lourence; Malgas, Cresshnik; Malgas, Keith; Marero, Bradley; Martinot, Zachary E.; Mesinger, Andrei; Molewa, Mathakane; Morales, Miguel F.; Mosiane, Tshagofalang; Neben, Abraham R.; Nikolic, Bojan; Nuwegeld, Hans; Parsons, Aaron R.; Patra, Nipanjana; Pieterse, Samantha; Razavi-Ghods, Nima; Robnett, James; Rosie, Kathryn; Sims, Peter; Smith, Craig; Swarts, Hilton; Thyagarajan, Nithyanandan; Van Wyngaarden, Pieter; Williams, Peter K. G.; Zheng, Haoxuan "Characterization Of Inpaint Residuals In Interferometric Measurements of the Epoch Of Reionization," *Monthly Notices of the Royal Astronomical Society*, 520, 5552-5572, 2023.
- Paggi, A.; Massaro, F.; Penã-Herazo, H.; Missaglia, V.; Jimenez-Gallardo, A.; Ricci, F.; Ettori, S.; Giovannini, G.; Govoni, F.; Baldi, R. D.; Mingo, B.; Murgia, M.; Liuzzo, E.; Galati, F. "The Multiwavelength Environment of Second Bologna Catalog Sources," *The Astrophysical Journal Supplement Series*, 268, 31, 2023.
- Paiano, Simona; Falomo, Renato; Treves, Aldo; Padovani, Paolo; Giommi, Paolo; Scarpa, Riccardo; Bisogni, Susanna; Marini, Ester "The spectra of IceCube Neutrino (SIN) candidate sources - III. Optical spectroscopy and source characterization of the full sample," *Monthly Notices of the Royal Astronomical Society*, 521, 2270, 2023.
- Paliya, Vaidehi S.; Saikia, D. J.; Stalin, C. S. "TXS 1433+205: The most distant gamma-ray emitting FR II radio galaxy," *Monthly Notices of the Royal Astronomical Society*, 520, L33, 2023.
- Palud, Pierre; Einig, Lucas; Le Petit, Franck; Bron, Émeric; Chainais, Pierre; Chanussot, Jocelyn; Pety, Jérôme; Thouvenin, Pierre-Antoine; Languignon, David; Bešlić, Ivana; Santa-Maria, Miriam G.; Orkisz, Jan H.; Ségal, Léontine E.; Zakardjian, Antoine; Bardeau, Sébastien; Gerin, Maryvonne; Goicoechea, Javier R.; Gratier, Pierre; Guzman, Viviana V.; Hughes, Annie; Levrier, François; Liszt, Harvey S.; Le Bourlot, Jacques; Roueff, Antoine; Sievers, Albrecht "Neural network-based emulation of interstellar medium models," *Astronomy and Astrophysics*, 678, A198, 2023.
- Pan, Hengxing; Jarvis, Matt J.; Santos, Mario G.; Maddox, Natasha; Frank, Bradley S.; Ponomareva, Anastasia A.; Prandoni, Isabella; Kurapati, Sushma; Baes, Maarten; Piña, Pavel E. Mancera; Rodighiero, Giulia; Meyer, Martin J.; Davé, Romeel; Sharma, Gauri; Rajhanson, Sambatriniaina H. A.; Adams, Nathan J.; Bowler, Rebecca A. A.; Sinigaglia, Francesco; Van Der Hulst, Thijs; Hatfield, Peter W.; Sekhar, Srikrishna; Collier, Jordan D. "MIGTEE-H I: the MH I - M\* relation over the last billion years," *Monthly Notices of the Royal Astronomical Society*, 525, 256, 2023.
- Panagiotou, Christos; De, Kishalay; Masterson, Megan; Kara, Erin; Calzadilla, Michael; Eilers, Anna-Christina; Frostig, Danielle; Karambelkar, Viraj; Kasliwal, Mansi; Lourie, Nathan; Meisner, Aaron M.; Simcoe, Robert A.; Stein, Robert; Zolkower, Jeffrey "A Luminous Dust-obscured Tidal Disruption Event Candidate in a Star-forming Galaxy at 42 Mpc," *The Astrophysical Journal*, 948, L5, 2023.
- Pandey, Rakesh; Sharma, Saurabh; Dewangan, Lokesh; Verma, Aayushi; Baug, Tapas; Kaur, Harmeen; Ghosh, Arpan "Investigating star-formation activity in Sh 2-61 H II region," *Journal of Astrophysics and Astronomy*, 44, 76, 2023.
- Pandhi, A.; Friesen, R. K.; Fissel, L.; Pineda, J. E.; Caselli, P.; Chen, M. C.-Y.; Di Francesco, J.; Ginsburg, A.; Kirk, H.; Myers, P. C.; Offner, S. S. R.; Punanova, A.; Quan, F.; Redaelli, E.; Rosolowsky, E.; Scibelli, S.; Seo, Y. M.; Shirley, Y. "Alignment of dense molecular core morphology and velocity gradients with ambient magnetic fields," *Monthly Notices of the Royal Astronomical Society*, 525, 364, 2023.
- Paneque-Carreño, T.; Miotello, A.; Van Dishoeck, E. F.; Tabone, B.; Izquierdo, A. F.; Facchini, S. "Directly tracing the vertical stratification of molecules in protoplanetary disks," *Astronomy and Astrophysics*, 669, A126, 2023.
- Pannikote, Meghana; Paliya, Vaidehi S.; Saikia, D. J. "Hunting Gamma-Ray-emitting FRO Radio Galaxies in Wide-field Sky Surveys," *The Astrophysical Journal*, 957, 73, 2023.
- Panther, Fiona H.; Anderson, Gemma E.; Bhandari, Shivani; Goodwin, Adelle J.; Hurley-Walker, Natasha; James, Clancy W.; Kawka, Adela; Ai, Shunke; Kovalam, Manoj; Moroiaru, Alexandra; Wen, Linqing; Zhang, Bing "The most probable host of CHIME FRB 190425A, associated with binary neutron star merger GW190425, and a late-time transient search," *Monthly Notices of the Royal Astronomical Society*, 519, 2235, 2023.
- Panurach, Teresa; Urquhart, Ryan; Strader, Jay; Chomiuk, Laura; Bahramian, Arash; Heinke, Craig O.; Maccarone, Thomas J.; Miller-Jones, James C. A.; Sivakoff, Gregory R. "Tracking the Enigmatic Globular Cluster Ultracompact X-Ray Binary X1850-087: Extreme Radio Variability in the Hard State," *The Astrophysical Journal*, 946, 88, 2023.
- Papachristou, M.; Dasyra, K. M.; Fernández-Ontiveros, J. A.; Audibert, A.;

## APPENDIX A: PUBLICATIONS

- Ruffa, I.; Combes, F.; Polkas, M.; Gkogkou, A. "A plausible link between dynamically unsettled molecular gas and the radio jet in NGC 6328," *Astronomy and Astrophysics*, 679, A115, 2023.
- Parlanti, E.; Carniani, S.; Pallottini, A.; Cignoni, M.; Cresci, G.; Kohandel, M.; Mannucci, F.; Marconi, A. "ALMA hints at the presence of turbulent disk galaxies at  $z > 5$ ," *Astronomy and Astrophysics*, 673, A153, 2023.
- Pascucci, Ilaria; Skinner, Bennett N.; Deng, Dingshan; Ruaud, Maxime; Gorti, Uma; Schwarz, Kamber R.; Chapillon, Edwige; Vioque, Miguel; Miley, James "Large Myr-old Disks Are Not Severely Depleted of Gas-phase CO or Carbon," *The Astrophysical Journal*, 953, 183, 2023.
- Pasham, Dheeraj R.; Lucchini, Matteo; Laskar, Tanmoy; Gompertz, Benjamin P.; Srivastav, Shubham; Nicholl, Matt; Smartt, Stephen J.; Miller-Jones, James C. A.; Alexander, Kate D.; Fender, Rob; Smith, Graham P.; Fulton, M.; Dewangan, Gulab; Gendreau, Keith; Coughlin, Eric R.; Rhodes, Lauren; Horesh, Assaf; Van Velzen, Sjoert; Sfaradi, Itai; Guolo, Muryel; Castro Segura, Noel; Aamer, Aysha; Anderson, Joseph P.; Arcavi, Iair; Brennan, Seán J.; Chambers, Kenneth; Charalampopoulos, Panos; Chen, Ting-Wan; Clocchiatti, A.; De Boer, Thomas; Dennefeld, Michel; Ferrara, Elizabeth; Galbany, Lluís; Gao, Hua; Gillanders, James H.; Goodwin, Adelle; Gromadzki, Mariusz; Huber, M.; Jonker, Peter G.; Joshi, Manasvita; Kara, Erin; Killestein, Thomas L.; Kosec, Peter; Kocevski, Daniel; Leloudas, Giorgos; Lin, Chien-Cheng; Margutti, Raffaella; Mattila, Seppo; Moore, Thomas; Müller-Bravo, Tomás; Ngeow, Chow-Choong; Oates, Samantha; Onori, Francesca; Pan, Yen-Chen; Perez-Torres, Miguel; Rani, Priyanka; Remillard, Ronald; Ridley, Evan J.; Schulze, Steve; Sheng, Xinyue; Shingles, Luke; Smith, Ken W.; Steiner, James F.; Wainscoat, Richard; Wevers, Thomas; Yang, Sheng "The Birth of a Relativistic Jet Following the Disruption of a Star by a Cosmological Black Hole," *Nature Astronomy*, 7, 88, 2023.
- Patel, Ekta; Mandel, Kaisey S. "Evidence for a Massive Andromeda Galaxy Using Satellite Galaxy Proper Motions," *The Astrophysical Journal*, 948, 104, 2023.
- Patra, Dushmantha; Joshi, Ravi; Gopal-Krishna "Spectral index variation across X-shaped radio galaxies," *Monthly Notices of the Royal Astronomical Society*, 524, 3270, 2023.
- Pattle, Kate; Gear, Walter; Wilson, Christine D. "The JCMT nearby galaxies legacy survey: SCUBA-2 observations of nearby galaxies," *Monthly Notices of the Royal Astronomical Society*, 522, 2339, 2023.
- Paul, Surajit; Kale, Ruta; Datta, Abhirup; Basu, Aritra; Sur, Sharanya; Parekh, Viral; Gupta, Prateek; Chatterjee, Swarna; Salunkhe, Sameer; Iqbal, Asif; Pandey-Pommier, Mamta; Raja, Ramij; Rahaman, Majidul; Raychaudhury, Somak; Nath, Biman B.; Majumdar, Subhabrata "Exploring diffuse radio emission in galaxy clusters and groups with uGMRT and SKA," *Journal of Astrophysics and Astronomy*, 44, 38, 2023.
- Pazukhin, A. G.; Zinchenko, I. I.; Trofimova, E. A.; Henkel, C.; Semenov, D. A. "Variations of the HCO+, HCN, HNC, N2H+, and NH3 deuterium fractionation in high-mass star-forming regions," *Monthly Notices of the Royal Astronomical Society*, 526, 3673, 2023.
- Pegues, Jamila; Öberg, Karin I.; Qi, Chunhua; Andrews, Sean M.; Huang, Jane; Law, Charles J.; Le Gal, Romane; Matrà, Luca; Wilner, David J. "An SMA Survey of Chemistry in Disks Around Herbig AeBe Stars," *The Astrophysical Journal*, 948, 57, 2023.
- Peiřker, Florian; Zajaček, Michal; Sabha, Nadeen B.; Tsuboi, Masato; Moulataka, Jihane; Labadie, Lucas; Eckart, Andreas; Karas, Vladimír; Steiniger, Lukas; Subroweit, Matthias; Suresh, Anjana; Melamed, Maria; Clénet, Yann "X3: A High-mass Young Stellar Object Close to the Supermassive Black Hole Sgr A\*," *The Astrophysical Journal*, 944, 231, 2023.
- Peiřker, Florian; Zajaček, Michal; Thomkins, Lauritz; Eckart, Andreas; Labadie, Lucas; Karas, Vladimír; Sabha, Nadeen B.; Steiniger, Lukas; Melamed, Maria "The Evaporating Massive Embedded Stellar Cluster IRS 13 Close to Sgr A\*. I. Detection of a Rich Population of Dusty Objects in the IRS 13 Cluster," *The Astrophysical Journal*, 956, 70, 2023.
- Peltonen, Joshua; Rosolowsky, Erik; Johnson, L. Clifton; Seth, Anil C.; Dalcanton, Julianne; Bell, Eric F.; Braine, Jonathan; Koch, Eric W.; Lazzarini, Margaret; Leroy, Adam K.; Skillman, Evan D.; Smercina, Adam; Wainer, Tobin; Williams, Benjamin F. "Clusters, clouds, and correlations: relating young clusters to giant molecular clouds in M33 and M31," *Monthly Notices of the Royal Astronomical Society*, 522, 6137, 2023.
- Peng, Bo; Vishwas, Amit; Stacey, Gordon; Nikola, Thomas; Lamarche, Cody; Rooney, Christopher; Ball, Catie; Ferkinhoff, Carl; Spoon, Henrik "Discovery of a Dusty, Chemically Mature Companion to a  $z \sim 4$  Starburst Galaxy in JWST ERS Data," *The Astrophysical Journal*, 944, L36, 2023.
- Peng, Sijia; Li, Zhiyuan; Sjouwerman, Loránt O.; Yang, Yang; Jiang, Wu; Shen, Zhi-Qiang "Searching for Radio Outflows from M31\* with VLBI Observations," *The Astrophysical Journal*, 953, 12, 2023.
- Peralta De Arriba, L.; Alonso-Herrero, A.; García-Burillo, S.; García-Berete, I.; Villar-Martín, M.; García-Lorenzo, B.; Davies, R.; Rosario, D. J.; Hönl, S. F.; Levenson, N. A.; Packham, C.; Ramos Almeida, C.; Pereira-Santaella, M.; Audibert, A.; Bellocchi, E.; Hicks, E. K. S.; Labiano, A.; Ricci, C.; Rigopoulou, D. "A radio-jet-driven outflow in the Seyfert 2 galaxy NGC 2110?," *Astronomy and Astrophysics*, 675, A58, 2023.
- Perez, Karen I.; Bogdanov, Slavko; Halpern, Jules P.; Gajjar, Vishal "Green Bank Telescope Discovery of the Redback Binary Millisecond Pulsar PSR J0212+5321," *The Astrophysical Journal*, 952, 150, 2023.
- Perger, Krisztina; Frey, Sándor; Gabányi, Krisztina Éva "Radio and mid-infrared properties of the blazar J1419-0838," *Astrophysics and Space Science*, 368, 18, 2023.
- Perotti, G.; Jørgensen, J. K.; Rocha, W. R. M.; Plunkett, A.; Artur De La Villarmois, E.; Kristensen, L. E.; Sewilo, M.; Bjerkeli, P.; Fraser, H. J.; Charney, S. B. "Linking ice and gas in the Coronet cluster in Corona Australis," *Astronomy and Astrophysics*, 678, A78, 2023.
- Perrotta, Francesca; Giulietti, Marika; Massardi, Marcella; Gandolfi, Giovanni; Ronconi, Tommaso; Zanchettin, Maria Vittoria; Amato, Quirino D.; Behiri, Meriem; Torsello, Martina; Gabrielli, Francesco; Boco, Lumen; Galluzzi, Vincenzo; Lapi, Andrea "The Way of Water: ALMA Resolves H2O Emission Lines in a Strongly Lensed Dusty Star-forming Galaxy at  $z \sim 3.1$ ," *The Astrophysical Journal*, 952, 90, 2023.
- Perrotta, Serena; Coil, Alison L.; Rupke, David S. N.; Tremonti, Christy A.; Davis, Julie D.; Diamond-Stanic, Aleksandar M.; Geach, James E.; Hickox, Ryan C.; Moustakas, John; Rudnick, Gregory H.; Sell, Paul H.; Swiggum, Cameren N.; Whalen, Kelly E. "Kinematics, Structure, and Mass Outflow Rates of Extreme Starburst Galactic Outflows," *The Astrophysical Journal*, 949, 9, 2023.
- Pesce, Dominic W.; Braatz, James A.; Henkel, Christian; Humphreys, Elizabeth M. L.; Impellizzeri, C. M. Violette; Kuo, Cheng-Yu "183 GHz Water Megamasers in Active Galactic Nuclei: A New Accretion Disk Tracer," *The Astrophysical Journal*, 948, 134, 2023.
- Pessa, I.; Schinnerer, E.; Sanchez-Blazquez, P.; Belfiore, F.; Groves, B.; Emsellem, E.; Neumann, J.; Leroy, A. K.; Bigiel, F.; Chevance, M.; Dale, D. A.; Glover, S. C. O.; Grasha, K.; Klessen, R. S.; Kreckel, K.; Kruijssen, J. M. D.; Pinna, F.; Querejeta, M.; Rosolowsky, E.; Williams, T. G. "Resolved stellar population properties of PHANGS-MUSE galaxies," *Astronomy and Astrophysics*, 673, A147, 2023.
- Petrov, Leonid "Single-band VLBI Absolute Astrometry," *The Astronomical Journal*, 165, 183, 2023.
- Piccirilli, G.; Migliaccio, M.; Branchini, E.; Dolfi, A. "A cross-correlation analysis of CMB lensing and radio galaxy maps," *Astronomy and Astrophysics*, 671, A42, 2023.
- Pineda, J. Sebastian; Villadsen, Jackie "Coherent radio bursts from known M-dwarf planet-host YZ Ceti," *Nature Astronomy*, 7, 569, 2023.
- Pinte, C.; Hammond, I.; Price, D. J.; Christiaens, V.; Andrews, S. M.; Chauvin, G.; Pérez, L. M.; Jorquera, S.; Garg, H.; Norfolk, B. J.; Calcinò, J.; Bonnefoy, M. "Kinematic and thermal signatures of the directly imaged protoplanet candidate around elias 2-24," *Monthly Notices of the Royal Astronomical Society*, 526, L41, 2023.
- Pizzati, Elia; Rosotti, Giovanni P.; Tabone, Benoît "Constraining turbulence in protoplanetary discs using the gap contrast: an application to the

- DSHARP sample," *Monthly Notices of the Royal Astronomical Society*, 524, 3184, 2023.
- Plavin, A. V.; Kovalev, Y. Y.; Kovalev, Yu A.; Troitsky, S. V. "Growing evidence for high-energy neutrinos originating in radio blazars," *Monthly Notices of the Royal Astronomical Society*, 523, 1799, 2023.
- Plunkett, Adele; Hacar, Alvaro; Moser-Fischer, Lydia; Petry, Dirk; Teuben, Peter; Pingel, Nickolas; Kunneriath, Devaky; Takagi, Toshinobu; Miyamoto, Yusuke; Moravec, Emily; Suri, Sümeyye; Hess, Kelley M.; Hoffman, Melissa; Mason, Brian "Data Combination: Interferometry and Single-dish Imaging in Radio Astronomy," *Publications of the Astronomical Society of the Pacific*, 135, 34501, 2023.
- Poitevineau, R.; Castignani, G.; Combes, F. "Black hole and galaxy co-evolution in radio-loud active galactic nuclei at  $z \sim 0.3-4$ ," *Astronomy and Astrophysics*, 672, A164, 2023.
- Pokhrel, Ritwaj; Megeath, S. Thomas; Gutermuth, Robert A.; Furlan, Elise; Fischer, William J.; Federman, Samuel; Tobin, John J.; Stutz, Amelia M.; Hartmann, Lee; Osorio, Mayra; Watson, Dan M.; Stanke, Thomas; Manoj, P.; Narang, Mayank; Atnagulov, Prabhani; Habel, Nolan; Zakri, Wafa "Extension of HOPS out to 500 pc (eHOPS). I. Identification and Modeling of Protostars in the Aquila Molecular Clouds," *The Astrophysical Journal Supplement Series*, 266, 32, 2023.
- Polisensky, Emil; Das, Barnali; Peters, Wendy; Shultz, Matt E.; Semenko, Eugene; Clarke, Tracy E. "Unstable Phenomena in Stable Magnetospheres: Searching for Radio Flares from Magnetic OBA Stars Using VCSS," *The Astrophysical Journal*, 958, 152, 2023.
- Ponomareva, Anastasia A.; Jarvis, Matt J.; Pan, Hengxing; Maddox, Natasha; Jones, Michael G.; Frank, Bradley S.; Rajohnson, Sambatriniaina H. A.; Mulaudzi, Wang; Meyer, Martin; Adams, Elizabeth A. K.; Baes, Maarten; Hess, Kelley M.; Kurapati, Sushma; Prandoni, Isabella; Sinigaglia, Francesco; Spekkens, Kristine; Tudorache, Madalina; Heywood, Ian; Collier, Jordan D.; Sekhar, Srikrishna "MIGHTEE-H I: the first MeerKAT HI mass function from an untargeted interferometric survey," *Monthly Notices of the Royal Astronomical Society*, 522, 5308, 2023.
- Pope, Alexandra; Mckinney, Jed; Kamienski, Patrick; Battisti, Andrew; Aretxaga, Itziar; Brammer, Gabriel; Diego, Jose M.; Hughes, David H.; Keller, Erica; Marchesini, Danilo; Mizener, Andrew; Montaña, Alfredo; Murphy, Eric; Whitaker, Katherine E.; Wilson, Grant; Yun, Min "ALMA Reveals a Stable Rotating Gas Disk in a Paradoxical Low-mass, Ultradusty Galaxy at  $z = 4.274$ ," *The Astrophysical Journal*, 951, L46, 2023.
- Popov, M. V.; Bartel, N.; Andrianov, A. S.; Burgin, M. S.; Fadeev, E. N.; Rudnitskiy, A. G.; Smirnova, T. V.; Soglasnov, V. A.; Zuga, V. A. "Technical Constraints on Interstellar Interferometry and Spatially Resolving the Pulsar Magnetosphere," *The Astrophysical Journal*, 954, 126, 2023.
- Popping, Gergő "An upper limit on [O III] 88  $\mu\text{m}$  and 1.2 mm continuum emission from a JWST  $z \approx 12-13$  galaxy candidate with ALMA," *Astronomy and Astrophysics*, 669, L8, 2023.
- Popping, Gergő; Shivaie, Irene; Sanders, Ryan L.; Jones, Tucker; Pope, Alexandra; Reddy, Naveen A.; Shapley, Alice E.; Coil, Alison L.; Kriek, Mariska "The dust-to-gas mass ratio of luminous galaxies as a function of their metallicity at cosmic noon," *Astronomy and Astrophysics*, 670, A138, 2023.
- Posses, A. C.; Aravena, M.; González-López, J.; Assef, R. J.; Lambert, T.; Jones, G. C.; Bouwens, R. J.; Brisbin, D.; Díaz-Santos, T.; Herrera-Camus, R.; Ricci, C.; Smit, R. "Structure and kinematics of a massive galaxy at  $z \sim 7$ ," *Astronomy and Astrophysics*, 669, A46, 2023.
- Pouteau, Y.; Motte, F.; Nony, T.; González, M.; Joncour, I.; Robitaille, J.-F.; Busquet, G.; Galván-Madrid, R.; Gusdorf, A.; Hennebelle, P.; Ginsburg, A.; Csengeri, T.; Sanhueza, P.; Dell'Ova, P.; Stutz, A. M.; Towner, A. P. M.; Cunningham, N.; Louvet, F.; Men'Shchikov, A.; Fernández-López, M.; Schneider, N.; Armante, M.; Bally, J.; Baug, T.; Bonfand, M.; Bontemps, S.; Bronfman, L.; Brouillet, N.; Díaz-González, D.; Herpin, F.; Lefloch, B.; Liu, H.-L.; Lu, X.; Nakamura, F.; Luong, Q. Nguyen; Olguin, F.; Tatematsu, K.; Valeille-Manet, M. "ALMA-IMF. VI. Investigating the origin of stellar masses: Core mass function evolution in the W43-MM2&MM3 mini-starburst," *Astronomy and Astrophysics*, 674, A76, 2023.
- Powell, Devon M.; Vegetti, Simona; Mckean, J. P.; White, Simon D. M.; Ferreira, Elisa G. M.; May, Simon; Spingola, Cristiana "A lensed radio jet at milli-arcsecond resolution - II. Constraints on fuzzy dark matter from an extended gravitational arc," *Monthly Notices of the Royal Astronomical Society*, 524, L84, 2023.
- Prabu, S.; Miller-Jones, J. C. A.; Bahramian, A.; Wood, C. M.; Tingay, S. J.; Atri, P.; Plotkin, R. M.; Strader, J. "Probing the jet size of two black hole X-ray binaries in the hard state," *Monthly Notices of the Royal Astronomical Society*, 525, 4426, 2023.
- Prasad, Sirina; Zhang, Qizhou; Moran, James; Cao, Yue; Jimenez-Serra, Izaskun; Martín-Pintado, Jesus; Martínez-Henares, Antonio; Báez-Rubio, Alejandro "Detection of a High-velocity Jet from MWC 349A Traced by Hydrogen Recombination Line Maser Emission," *The Astrophysical Journal*, 953, L6, 2023.
- Prather, Ben S.; Dexter, Jason; Moscibrodzka, Monika; Pu, Hung-Yi; Bronzwaer, Thomas; Davelaar, Jordy; Younsi, Ziri; Gammie, Charles F.; Gold, Roman; Wong, George N.; Akiyama, Kazunori; Alberdi, Antxon; Alef, Walter; Algaba, Juan Carlos; Anantua, Richard; Asada, Keiichi; Azulay, Rebecca; Bach, Uwe; Baczko, Anne-Kathrin; Ball, David; Baloković, Mislav; Barrett, John; Bauböck, Michi; Benson, Bradford A.; Bintley, Dan; Blackburn, Lindy; Blundell, Raymond; Bouman, Katherine L.; Bower, Geoffrey C.; Boyce, Hope; Bremer, Michael; Brinkerink, Christiaan D.; Brissenden, Roger; Britzen, Silke; Broderick, Avery E.; Brogiere, Dominique; Bustamante, Sandra; Byun, Do-Young; Carlstrom, John E.; Ceccobello, Chiara; Chael, Andrew; Chan, Chi-Kwan; Chang, Dominic O.; Chatterjee, Koushik; Chatterjee, Shami; Chen, Ming-Tang; Chen, Yongjun; Cheng, Xiaopeng; Cho, Ilje; Christian, Pierre; Conroy, Nicholas S.; Conway, John E.; Cordes, James M.; Crawford, Thomas M.; Crew, Geoffrey B.; Cruz-Osorio, Alejandro; Cui, Yuzhu; De Laurentis, Mariafelicia; Deane, Roger; Dempsey, Jessica; Desvignes, Gregory; Dhruv, Vedant; Doleman, Sheperd S.; Dougal, Sean; Dzib, Sergio A.; Eatough, Ralph P.; Emami, Razieh; Falcke, Heino; Farah, Joseph; Fish, Vincent L.; Fomalont, Ed; Ford, H. Alyson; Fraga-Encinas, Raquel; Freeman, William T.; Friberg, Per; Fromm, Christian M.; Fuentes, Antonio; Galison, Peter; Garcia, Roberto; Gentaz, Olivier; Georgiev, Boris; Goddi, Ciriaco; Gómez-Ruiz, Arturo I.; Gómez, José L.; Gu, Minfeng; Gurwell, Mark; Hada, Kazuhiro; Haggard, Daryl; Haworth, Kari; Hecht, Michael H.; Hesper, Ronald; Heumann, Dirk; Ho, Luis C.; Ho, Paul; Honma, Mareki; Huang, Chih-Wei L.; Huang, Lei; Hughes, David H.; Ikeda, Shiro; Impellizzeri, C. M. Violette; Inoue, Makoto; Issaoun, Sara; James, David J.; Jannuzi, Buell T.; Janssen, Michael; Jeter, Britton; Jiang, Wu; Jiménez-Rosales, Alejandra; Johnson, Michael D.; Jorstad, Svetlana; Joshi, Abhishek V.; Jung, Taehyun; Karami, Mansour; Karuppusamy, Ramesh; Kawashima, Tomohisa; Keating, Garrett K.; Kettenis, Mark; Kim, Dong-Jin; Kim, Jae-Young; Kim, Jongsoo; Kim, Junhan; Kino, Motoki; Koay, Jun Yi; Kocherlakota, Prashant; Kofuji, Yutaro; Koyama, Shoko; Kramer, Carsten; Kramer, Michael; Krichbaum, Thomas P.; Kuo, Cheng-Yu; La Bella, Noemi; Lauer, Tod R.; Lee, Daeyoung; Lee, Sang-Sung; Leung, Po Kin; Levis, Aviad; Li, Zhiyuan; Lico, Rocco; Lindahl, Greg; Lindqvist, Michael; Lisakov, Mikhail; Liu, Jun; Liu, Kuo; Liuzzo, Elisabetta; Lo, Wen-Ping; Lobanov, Andrei P.; Loinard, Laurent; Lonsdale, Colin J.; Lu, Ru-Sen; Macdonald, Nicholas R.; Mao, Jirong; Marchili, Nicola; Markoff, Sera; Marrone, Daniel P.; Marscher, Alan P.; Martí-Vidal, Iván; Matsushita, Satoki; Matthews, Lynn D.; Medeiros, Lia; Menten, Karl M.; Michalik, Daniel; Mizuno, Izumi; Mizuno, Yosuke; Moran, James M.; Moriyama, Kotaro; Müller, Cornelia; Mus, Alejandro; Musoke, Gibwa; Myserlis, Ioannis; Nadolski, Andrew; Nagai, Hiroshi; Nagar, Neil M.; Nakamura, Masanori; Narayan, Ramesh; Narayanan, Gopal; Natarajan, Iniyang; Nathanail, Antonios; Fuentes, Santiago Navarro; Neilsen, Joey; Neri, Roberto; Ni, Chunchong; Noutsos, Aristeidis; Nowak, Michael A.; Oh, Junghwan; Okino, Hiroki; Olivares, Héctor; Ortiz-León, Gisela N.; Oyama, Tomoaki; Özel, Feryal; Palumbo, Daniel C. M.; Paraschos, Georgios Filippou; Park, Jongho; Parsons, Harriet; Patel, Nimesh; Pen, Ue-Li; Pesce, Dominic

## APPENDIX A: PUBLICATIONS

- W.; Piétu, Vincent; Plambeck, Richard; Popstefanija, Aleksandar; Porth, Oliver; Pötzl, Felix M.; Preciado-López, Jorge A.; Psaltis, Dimitrios; Ramakrishnan, Venkatesh; Rao, Ramprasad; Rawlings, Mark G.; Raymond, Alexander W.; Rezzolla, Luciano; Ricarte, Angelo; Ripperda, Bart; Roelofs, Freek; Rogers, Alan; Ros, Eduardo; Romero-Cañizales, Cristina; Roshanineshat, Arash; Rottmann, Helge; Roy, Alan L.; Ruiz, Ignacio; Ruszczyk, Chet; Rygl, Kazi L. J.; Sánchez, Salvador; Sánchez-Argüelles, David; Sánchez-Portal, Miguel; Sasada, Mahito; Satapathy, Kaushik; Savolainen, Tuomas; Schloerb, F. Peter; Schonfeld, Jonathan; Schuster, Karl-Friedrich; Shao, Lijing; Shen, Zhiqiang; Small, Des; Sohn, Bong Won; Soohoo, Jason; Souccar, Kamal; Sun, He; Tazaki, Fumie; Tetarenko, Alexandra J.; Tiede, Paul; Tilanus, Remo P. J.; Titus, Michael; Torne, Pablo; Traianou, Efthalia; Trent, Tyler; Trippe, Sascha; Turk, Matthew; Van Bemmell, Ilse; Van Langevelde, Huib Jan; Van Rossum, Daniel R.; Vos, Jesse; Wagner, Jan; Ward-Thompson, Derek; Wardle, John; Weintraub, Jonathan; Wex, Norbert; Wharton, Robert; Wielgus, Maciek; Wiik, Kaj; Witzel, Gunther; Wondrak, Michael F.; Wu, Qingwen; Yamaguchi, Paul; Yfantis, Aristomenis; Yoon, Doosoo; Young, André; Young, Ken; Yu, Wei; Yuan, Feng; Yuan, Ye-Fei; Zensus, J. Anton; Zhang, Shuo; Zhao, Guang-Yao; Zhao, Shan-Shan; Event Horizon Telescope Collaboration "Comparison of Polarized Radiative Transfer Codes Used by the EHT Collaboration," *The Astrophysical Journal*, 950, 35, 2023.
- Punsly, B. "HST-1 as a window into the energetics of the jet spine of M 87," *Astronomy and Astrophysics*, 677, A180, 2023.
- Pushkarev, A. B.; Aller, H. D.; Aller, M. F.; Homan, D. C.; Kovalev, Y. Y.; Lister, M. L.; Pashchenko, I. N.; Savolainen, T.; Zobnina, D. I. "MOJAVE - XX. Persistent linear polarization structure in parsec-scale AGN jets," *Monthly Notices of the Royal Astronomical Society*, 520, 6053, 2023.
- Quintana-Lacaci, G.; Veilla-Prieto, L.; Agúndez, M.; Fonfría, J. P.; Cernicharo, J.; Decin, L.; Castro-Carrizo, A. "History of two mass loss processes in YY CMa. Fast outflows carving older ejecta," *Astronomy and Astrophysics*, 669, A56, 2023.
- Quiroga-González, D.; Trinidad, M. A.; De La Fuente, E.; Masqué, J. M.; Rodríguez-Esnard, T. "Search and Study of Ultracompact H II Regions," *Revista Mexicana de Astronomía y Astrofísica*, 59, 279, 2023.
- Rajpurohit, K.; Osinga, E.; Brienza, M.; Botteon, A.; Brunetti, G.; Forman, W. R.; Riseley, C. J.; Vazza, F.; Bonafede, A.; Van Weeren, R. J.; Brüggem, M.; Rajpurohit, S.; Drabent, A.; Dallacasa, D.; Rossetti, M.; Rajpurohit, A. S.; Hoefl, M.; Bonnassieux, E.; Cassano, R.; Miley, G. K. "Deep low-frequency radio observations of Abell 2256. II. The ultra-steep spectrum radio halo," *Astronomy and Astrophysics*, 669, A1, 2023.
- Rao, Vaishnav V.; Kharb, P.; Rubinur, K.; Silpa, S.; Roy, N.; Sebastian, B.; Singh, V.; Baghel, J.; Manna, S.; Ishwara-Chandra, C. H. "AGN Feedback Through Multiple Jet Cycles in the Seyfert Galaxy NGC 2639," *Monthly Notices of the Royal Astronomical Society*, 524, 1615, 2023.
- Redaelli, E.; Bizzocchi, L.; Caselli, P.; Pineda, J. E. "Nitrogen fractionation in ammonia and its insights into nitrogen chemistry," *Astronomy and Astrophysics*, 674, L8, 2023.
- Reddy, Karthik; Georganopoulos, Markos; Meyer, Eileen T.; Keenan, Mary; Kollmann, Cassidy E. "Offsets between X-Ray and Radio Components in X-Ray Jets: The AtlasX," *The Astrophysical Journal Supplement Series*, 265, 8, 2023.
- Reid, M. J.; Miller-Jones, J. C. A. "On the Distances to the X-Ray Binaries Cygnus X-3 and GRS 1915+105," *The Astrophysical Journal*, 959, 85, 2023.
- Reipurth, Bo; Bally, J.; Yen, Hsi-Wei; Arce, H. G.; Rodríguez, L.-F.; Raga, A. C.; Geballe, T. R.; Rao, R.; Comerón, F.; Mikkola, S.; Aspin, C. A.; Walawender, J. "The HH 24 Complex: Jets, Multiple Star Formation, and Orphaned Protostars," *The Astronomical Journal*, 165, 209, 2023.
- Reiter, Megan; Klaassen, P. D.; Moser-Fischer, L.; Mcleod, A. F.; Itrich, D. "Into the Mystic: ALMA ACA observations of the Mystic Mountains in Carina," *Monthly Notices of the Royal Astronomical Society*, 526, 717, 2023.
- Remijan, Anthony; Scolati, Haley N.; Burkhardt, Andrew M.; Changala, P. Bryan; Charnley, Steven B.; Cooke, Ilsa R.; Cordiner, Martin A.; Gupta, Harshal; Herbst, Eric; Kelvin Lee, Kin Long; Loomis, Ryan A.; Shingledecker, Christopher N.; Siebert, Mark A.; Xue, Ci; Mccarthy, Michael C.; Mcguire, Brett A. "Astronomical Detection of the Interstellar Anion C10H- toward TMC-1 from the GOTHAM Large Program on the Green Bank Telescope," *The Astrophysical Journal*, 944, L45, 2023.
- Ren, Yi W.; Fudamoto, Yoshinobu; Inoue, Akio K.; Sugahara, Yuma; Tokuoka, Tsuyoshi; Tamura, Yoichi; Matsuo, Hiroshi; Kohno, Kotaro; Umehata, Hideki; Hashimoto, Takuya; Bouwens, Rychard J.; Smit, Renske; Kashikawa, Nobunari; Okamoto, Takashi; Shibuya, Takatoshi; Shimizu, Ikkoh "Updated Measurements of [O III] 88  $\mu\text{m}$ , [C II] 158  $\mu\text{m}$ , and Dust Continuum Emission from a  $z = 7.2$  Galaxy," *The Astrophysical Journal*, 945, 69, 2023.
- Ren, Zhiyuan; Chen, Xi; Liu, Tie; Mannfors, Emma; Bronfman, Leonardo; Xu, Fengwei; Feng, Siyi; Liu, Hongli; Meng, Fanyi; Stutz, Amelia M.; Li, Shanghuo; Lee, Chang Won; Wang, Ke; Zhou, Jianwen; Li, Di; Wang, Chen; Eswarajah, Chakali; Tej, Anandmayee; Chen, Long-Fei; Shi, Hui "A High-mass, Young Star-forming Core Escaping from Its Parental Filament," *The Astrophysical Journal*, 955, 104, 2023.
- Restrepo, O. A.; Lucero, F. I.; Chaparro, G.; Rodríguez, R.; Pizarro, F.; Bustos, R.; Díaz, M.; Mena, F. P. "Optimization of Antenna Performance for Global 21 cm Observations and Verification Using Scaled Copies," *Journal of Astronomical Instrumentation*, 12, 2350005, 2023.
- Reuter, C.; Spilker, J. S.; Vieira, J. D.; Marrone, D. P.; Weiss, A.; Aravena, M.; Archipley, M. A.; Chapman, S. C.; Gonzalez, A.; Greve, T. R.; Hayward, C. C.; Hill, R.; Jarugula, S.; Kim, S.; Malkan, M.; Phadke, K. A.; Stark, A. A.; Sulzenauer, N.; Vizgan, D. "The Rest-frame Submillimeter Spectrum of High-redshift, Dusty, Star-forming Galaxies from the SPT-SZ Survey," *The Astrophysical Journal*, 948, 44, 2023.
- Rhodes, L.; Bright, J. S.; Fender, R.; Sfaradi, I.; Green, D. A.; Horesh, A.; Mooley, K.; Pasham, D.; Smartt, S.; Titterton, D. J.; Van Der Horst, A. J.; Williams, D. R. A. "Day-timescale variability in the radio light curve of the Tidal Disruption Event AT2022cmc: Confirmation of a highly relativistic outflow," *Monthly Notices of the Royal Astronomical Society*, 521, 389-395, 2023.
- Ribas, Á.; Macías, E.; Weber, P.; Pérez, S.; Cuello, N.; Dong, R.; Aguayo, A.; Cáceres, C.; Carpenter, J.; Dent, W. R. F.; De Gregorio-Monsalvo, I.; Duchêne, G.; Espaillat, C. C.; Riviere-Marichalar, P.; Villenave, M. "The ALMA view of MP Mus (PDS 66): A protoplanetary disk with no visible gaps down to 4 au scales," *Astronomy and Astrophysics*, 673, A77, 2023.
- Ricci, C.; Ichikawa, K.; Stalevski, M.; Kawamuro, T.; Yamada, S.; Ueda, Y.; Mushotzky, R.; Privon, G. C.; Koss, M. J.; Trakhtenbrot, B.; Fabian, A. C.; Ho, L. C.; Asmus, D.; Bauer, F. E.; Chang, C. S.; Gupta, K. K.; Oh, K.; Powell, M.; Pfeifle, R. W.; Rojas, A.; Ricci, F.; Temple, M. J.; Toba, Y.; Tortosa, A.; Treister, E.; Harrison, F.; Stern, D.; Urry, C. M. "BASS. XLII. The Relation between the Covering Factor of Dusty Gas and the Eddington Ratio in Nearby Active Galactic Nuclei," *The Astrophysical Journal*, 959, 27, 2023.
- Ricci, Claudio; Chang, Chin-Shin; Kawamuro, Taiki; Privon, George C.; Mushotzky, Richard; Trakhtenbrot, Benny; Laor, Ari; Koss, Michael J.; Smith, Krista L.; Gupta, Kriti K.; Dimopoulos, Georgios; Aalto, Susanne; Ros, Eduardo "A Tight Correlation between Millimeter and X-Ray Emission in Accreting Massive Black Holes from <100 mas Resolution ALMA Observations," *The Astrophysical Journal*, 952, L28, 2023.
- Rich, J.; Aalto, S.; Evans, A. S.; Charmandaris, V.; Privon, G. C.; Lai, T.; Inami, H.; Linden, S.; Armus, L.; Diaz-Santos, T.; Appleton, P.; Barcos-Muñoz, L.; Böker, T.; Larson, K. L.; Law, D. R.; Malkan, M. A.; Medling, A. M.; Song, Y.; U. V.; Van Der Werf, P.; Bohn, T.; Brown, M. J. I.; Finnerty, L.; Hayward, C.; Howell, J.; Iwasawa, K.; Kemper, F.; Marshall, J.; Mazzarella, J. M.; McKinney, J.; Muller-Sanchez, F.; Murphy, E. J.; Sanders, D.; Soifer, B. T.; Stierwalt, S.; Surace, J. "GOALS-JWST: Pulling Back the Curtain on the AGN and Star Formation in VV 114," *The Astrophysical Journal*, 944, L50, 2023.
- Ridder, M. E.; Heinke, C. O.; Sivakoff, G. R.; Hughes, A. K. "Radio detections of two unusual cataclysmic variables in the VLA Sky Survey," *Monthly Notices of the Royal Astronomical Society*, 519, 5922, 2023.

- Riggi, S.; Magro, D.; Sortino, R.; De Marco, A.; Bordiu, C.; Ceconello, T.; Hopkins, A. M.; Marvil, J.; Umana, G.; Sciacca, E.; Vitello, F.; Bufano, F.; Ingallinera, A.; Fiameni, G.; Spampinato, C.; Zarb Adami, K. "Astronomical source detection in radio continuum maps with deep neural networks," *Astronomy and Computing*, 42, 100682, 2023.
- Rigliaco, E.; Gratton, R.; Ceppi, S.; Ginski, C.; Hogerheijde, M.; Benisty, M.; Birnstiel, T.; Dima, M.; Facchini, S.; Garufi, A.; Bae, J.; Langlois, M.; Lodato, G.; Mamajek, E.; Manara, C. F.; Ménard, F.; Ribas, A.; Zurlo, A. "Disk Evolution Study Through Imaging of Nearby Young Stars (DESTINYS): Characterization of the young star T CrA and its circumstellar environment," *Astronomy and Astrophysics*, 671, A82, 2023.
- Riseley, C. J.; Biava, N.; Lusetti, G.; Bonafede, A.; Bonnassieux, E.; Botteon, A.; Loi, F.; Brunetti, G.; Cassano, R.; Osinga, E.; Rajpurohit, K.; Röttgering, H. J. A.; Shimwell, T.; Timmerman, R.; Van Weeren, R. J. "A MeerKAT-meets-LOFAR study of Abell 1413: a moderately disturbed non-cool-core cluster hosting a 500 kpc 'mini'-halo," *Monthly Notices of the Royal Astronomical Society*, 524, 6052, 2023.
- Rizzo, F.; Roman-Oliveira, F.; Fraternali, F.; Frickmann, D.; Valentino, F. M.; Brammer, G.; Zanella, A.; Kokorev, V.; Popping, G.; Whitaker, K. E.; Kohandel, M.; Magdis, G. E.; Di Mascolo, L.; Ikeda, R.; Jin, S.; Toft, S. "The ALMA-ALPAKA survey. I. High-resolution CO and [C] kinematics of star-forming galaxies at  $z = 0.5\text{--}3.5$ ," *Astronomy and Astrophysics*, 679, A129, 2023.
- Ro, Hyunwook; Kino, Motoki; Sohn, Bong Won; Hada, Kazuhiro; Park, Jongho; Nakamura, Masanori; Cui, Yuzhu; Yi, Kunwoo; Chung, Aeree; Hodgson, Jeffrey; Kawashima, Tomohisa; An, Tao; Trippe, Sascha; Algaba, Juan-Carlos; Kim, Jae-Young; Sawada-Satoh, Satoko; Wajima, Kiyooki; Shen, Zhiqiang; Cheng, Xiaopeng; Cho, Ilje; Jiang, Wu; Jung, Taehyun; Lee, Jee-Won; Niinuma, Kotaro; Oh, Junghwan; Tazaki, Fumie; Zhao, Guang-Yao; Akiyama, Kazunori; Honma, Mareki; Lee, Jeong Ae; Lu, Rusen; Zhang, Yingkang; Asada, Keiichi; Cui, Lang; Hagiwara, Yoshiaki; Hirota, Tomoya; Kawaguchi, Noriyuki; Koyama, Shoko; Lee, Sang-Sung; Oh, Se-Jin; Sugiyama, Koichiro; Takamura, Mieko; Wang, Xuezheng; Hwang, Ju-Yeon; Jung, Dong-Kyu; Kim, Hyo-Ryoung; Kim, Jeong-Sook; Kobayashi, Hideyuki; Oh, Chung-Sik; Oyama, Tomoaki; Roh, Duk-Gyoo; Yeom, Jae-Hwan "Spectral analysis of a parsec-scale jet in M 87: Observational constraint on the magnetic field strengths in the jet," *Astronomy and Astrophysics*, 673, A159, 2023.
- Roberts, Ian D.; Brown, Toby; Zabel, Nikki; Wilson, Christine D.; Chung, Aeree; Parker, Laura C.; Bisaria, Dhruv; Boselli, Alessandro; Catinella, Barbara; Chown, Ryan; Cortese, Luca; Davis, Timothy A.; Ellison, Sara; Jiménez-Donaire, María Jesús; Lee, Bumhyun; Smith, Rory; Spekkens, Kristine; Stevens, Adam R. H.; Thorp, Mallory; Villanueva, Vincente; Watts, Adam B.; Welker, Charlotte; Yoon, Hyein "VERTICO. VI. Cold-gas asymmetries in Virgo cluster galaxies," *Astronomy and Astrophysics*, 675, A78, 2023.
- Rodríguez, Luis F.; Lizano, Susana; Cantó, Jorge; González, Ricardo F. "Understanding the radio emission from Eridani," *Astronomy and Astrophysics*, 678, A185, 2023.
- Rodríguez, M. Jimena; Lee, Janice C.; Whitmore, B. C.; Thilker, David A.; Maschmann, Daniel; Chandar, Rupali; Deger, Sinan; Boquien, Médéric; Dale, Daniel A.; Larson, Kirsten L.; Williams, Thomas G.; Kim, Hwihyun; Schinnerer, Eva; Rosolowsky, Erik; Leroy, Adam G.; Emsellem, Eric; Sandstrom, Karin M.; Krujissen, J. M. Diederik; Gasha, Kathryn; Watkins, Elizabeth J.; Barnes, Ashley, T.; Sormani, Mattia C.; Kim, Jaeyeon; Anand, Gagandeep S.; Chevance, Mélanie; Bigiel, F.; Klessen, Ralf S.; Hassani, Hamid; Liu, Daizhong; Faesi, Christopher M.; Cao, Yixian; Belfiore, Francesco; Pessa, Ismael; Kreckel, Kathryn; Groves, Brent; Pety, Jérôme; Indebetouw, Rémy; Egorov, Oleg V.; Blanc, Guillermo A.; Saito, Toshiki; Hughes, Annie "PHANGS-JWST First Results: Dust-embedded Star Clusters in NGC 7496 Selected via 3.3  $\mu\text{m}$  PAH Emission," *The Astrophysical Journal*, 944, L26, 2023.
- Rodríguez, Tatiana M.; Hofner, Peter; Edelman, Isaac; Araya, Esteban D.; Rosero, Viviana "Searching for Molecular Jets from High-mass Protostars," *The Astrophysical Journal Supplement Series*, 264, 30, 2023.
- Roelofs, Freek; Johnson, Michael D.; Chael, Andrew; Janssen, Michael; Wielgus, Maciek; Broderick, Avery E.; Akiyama, Kazunori; Alberdi, Anthon; Alef, Walter; Algaba, Juan Carlos; Anantua, Richard; Asada, Keiichi; Azulay, Rebecca; Bach, Uwe; Baczko, Anne-Kathrin; Ball, David; Baloković, Mislav; Barrett, John; Bauböck, Michi; Benson, Bradford A.; Bintley, Dan; Blackburn, Lindy; Blundell, Raymond; Bouman, Katherine L.; Bower, Geoffrey C.; Boyce, Hope; Bremer, Michael; Brinkerink, Christiaan D.; Brissenden, Roger; Britzen, Silke; Brogiere, Dominique; Bronzwaer, Thomas; Bustamante, Sandra; Byun, Do-Young; Carlstrom, John E.; Ceccobello, Chiara; Chan, Chi-Kwan; Chang, Dominic O.; Chatterjee, Koushik; Chatterjee, Shami; Chen, Ming-Tang; Chen, Yongjun; Cheng, Xiaopeng; Cho, Ilje; Christian, Pierre; Conroy, Nicholas S.; Conway, John E.; Cordes, James M.; Crawford, Thomas M.; Crew, Geoffrey B.; Cruz-Osorio, Alejandro; Cui, Yuzhu; Dahale, Rohan; Davelaar, Jordy; De Laurentis, Mariafelicia; Deane, Roger; Dempsey, Jessica; Desvignes, Gregory; Dexter, Jason; Dhruv, Vedant; Doleman, Sheperd S.; Dougal, Sean; Dzib, Sergio A.; Eatough, Ralph P.; Emami, Razieh; Falcke, Heino; Farah, Joseph; Fish, Vincent L.; Fomalont, Ed; Ford, H. Alyson; Foschi, Marianna; Fraga-Encinas, Raquel; Freeman, William T.; Friberg, Per; Fromm, Christian M.; Fuentes, Antonio; Galson, Peter; Gammie, Charles F.; García, Roberto; Gentaz, Olivier; Georgiev, Boris; Goddi, Ciriaco; Gold, Roman; Gómez-Ruiz, Arturo I.; Gómez, José L.; Gu, Minfeng; Gurwell, Mark; Hada, Kazuhiro; Haggard, Daryl; Haworth, Kari; Hecht, Michael H.; Hesper, Ronald; Heumann, Dirk; Ho, Luis C.; Ho, Paul; Honma, Mareki; Huang, Chih-Wei L.; Huang, Lei; Hughes, David H.; Ikeda, Shiro; Impellizzeri, C. M. Violette; Inoue, Makoto; Issaoun, Sara; James, David J.; Jannuzi, Buell T.; Jeter, Britton; Jiang, Wu; Jiménez-Rosales, Alejandra; Jorstad, Svetlana; Joshi, Abhishek V.; Jung, Taehyun; Karami, Mansour; Karuppusamy, Ramesh; Kawashima, Tomohisa; Keating, Garrett K.; Kettenis, Mark; Kim, Dong-Jin; Kim, Jae-Young; Kim, Jongsoo; Kim, Junhan; Kino, Motoki; Koay, Jun Yi; Kocherlakota, Prashant; Kofuji, Yutarō; Koch, Patrick M.; Koyama, Shoko; Kramer, Carsten; Kramer, Joana A.; Kramer, Michael; Krichbaum, Thomas P.; Kuo, Cheng-Yu; La Bella, Noemi; Lauer, Tod R.; Lee, Daeyoung; Lee, Sang-Sung; Leung, Po Kin; Lewis, Aviad; Li, Zhiyuan; Lico, Rocco; Lindahl, Greg; Lindqvist, Michael; Lisakov, Mikhail; Liu, Jun; Liu, Kuo; Liuzzo, Elisabetta; Lo, Wen-Ping; Lobanov, Andrei P.; Loinard, Laurent; Lonsdale, Colin J.; Lowitz, Amy E.; Lu, Ru-Sen; Macdonald, Nicholas R.; Mao, Jirong; Marchili, Nicola; Markoff, Sera; Marrone, Daniel P.; Marscher, Alan P.; Martí-Vidal, Iván; Matsushita, Satoki; Matthews, Lynn D.; Medeiros, Lia; Menten, Karl M.; Michalik, Daniel; Mizuno, Izumi; Mizuno, Yosuke; Moran, James M.; Moriyama, Kotaro; Moscibrodzka, Monika; Muladzi, Wang; Müller, Cornelia; Müller, Hendrik; Mus, Alejandro; Musoke, Gibwa; Myserlis, Ioannis; Nadolski, Andrew; Nagai, Hiroshi; Nagar, Neil M.; Nakamura, Masanori; Narayanan, Gopal; Natarajan, Iniyān; Nathanael, Antonios; Fuentes, Santiago Navarro; Neilsen, Joey; Neri, Roberto; Ni, Chunchong; Noutsos, Aristeidis; Nowak, Michael A.; Oh, Junghwan; Okino, Hiroki; Olivares, Héctor; Ortiz-León, Gisela N.; Oyama, Tomoaki; Özel, Feryal; Palumbo, Daniel C. M.; Paraschos, Georgios Filippou; Park, Jongho; Parsons, Harriet; Patel, Nimesh; Pen, Ue-Li; Pesce, Dominic W.; Piétu, Vincent; Plambeck, Richard; Popstefanija, Aleksandar; Porth, Oliver; Pötzl, Felix M.; Prather, Ben; Preciado-López, Jorge A.; Psaltis, Dimitrios; Pu, Hung-Yi; Ramakrishnan, Venkatesh; Rao, Ramprasad; Rawlings, Mark G.; Raymond, Alexander W.; Rezzolla, Luciano; Ricarte, Angelo; Ripperda, Bart; Rogers, Alan; Romero-Cañizales, Cristina; Ros, Eduardo; Roshanineshat, Arash; Rottmann, Helge; Roy, Alan L.; Ruiz, Ignacio; Rusczyk, Chet; Rygl, Kazi L. J.; Sánchez, Salvador; Sánchez-Argüelles, David; Sánchez-Portal, Miguel; Sasada, Mahito; Satapathy, Kaushik; Savolainen, Tuomas; Schloerb, F. Peter; Schonfeld, Jonathan; Schuster, Karl-Friedrich; Shao, Lijing; Shen, Zhiqiang; Small, Des; Sohn, Bong Won; Soohoo, Jason; Sosapanta Salas, León David; Souccar, Kamal; Sun, He; Tazaki, Fumie; Tetarenko, Alexandra J.;

## APPENDIX A: PUBLICATIONS

- Tiede, Paul; Tilanus, Remo P. J.; Titus, Michael; Torne, Pablo; Toscano, Teresa; Traianou, Eftalia; Trent, Tyler; Trippe, Sascha; Turk, Matthew; Van Bemmell, Ilse; Van Langevelde, Huib Jan; Van Rossum, Daniel R.; Vos, Jesse; Wagner, Jan; Ward-Thompson, Derek; Wardle, John; Washington, Jasmin E.; Weintraub, Jonathan; Wharton, Robert; Wiik, Kaj; Witzel, Gunther; Wondrak, Michael F.; Wong, George N.; Wu, Qingwen; Yadlapalli, Nitika; Yamaguchi, Paul; Yfantis, Aristomenis; Yoon, Doosoo; Young, André; Young, Ken; Younsi, Ziri; Yu, Wei; Yuan, Feng; Yuan, Ye-Fei; Zensus, J. Anton; Zhang, Shuo; Zhao, Guang-Yao; Zhao, Shan-Shan "Polarimetric Geometric Modeling for mm-VLBI Observations of Black Holes," *The Astrophysical Journal*, 957, L21, 2023.
- Roman-Oliveira, Fernanda; Fraternali, Filippo; Rizzo, Francesca "Regular rotation and low turbulence in a diverse sample of  $z \sim 4.5$  galaxies observed with ALMA," *Monthly Notices of the Royal Astronomical Society*, 521, 1045, 2023.
- Romanowsky, Aaron J.; Larsen, Søren S.; Villaume, Alexa; Carlin, Jeffrey L.; Janz, Joachim; Sand, David J.; Strader, Jay; Brodie, Jean P.; Chakrabarti, Sukanya; Cheng, Chloe M.; Crnojević, Denija; Forbes, Duncan A.; Garling, Christopher T.; Hargis, Jonathan R.; Karunakaran, Ananthan; Martín-Navarro, Ignacio; Olsen, Knut A. G.; Rider, Nicole; Salimkumar, Bitha; Santhanakrishnan, Vakini; Spekkens, Kristine; Tang, Yimeng; Van Dokkum, Pieter G.; Willman, Beth "Low-density star cluster formation: discovery of a young faint fuzzy on the outskirts of the low-mass spiral galaxy NGC 247," *Monthly Notices of the Royal Astronomical Society*, 518, 3164, 2023.
- Romeo, Alessandro B.; Agertz, Oscar; Renaud, Florent "The specific angular momentum of disc galaxies and its connection with galaxy morphology, bar structure, and disc gravitational instability," *Monthly Notices of the Royal Astronomical Society*, 518, 1002, 2023.
- Romero, Charles E.; Gaspari, Massimo; Schellenberger, Gerrit; Bhandarkar, Tanay; Devlin, Mark; Dicker, Simon R.; Forman, William; Khatri, Rishi; Kraft, Ralph; Di Mascolo, Luca; Mason, Brian S.; Moravec, Emily; Mroczkowski, Tony; Nulsen, Paul; Orłowski-Scherer, John; Perez Sarmiento, Karen; Sarazin, Craig; Sievers, Jonathan; Su, Yuanyuan "Inferences from Surface Brightness Fluctuations of Zwicky 3146 via the Sunyaev-Zel'dovich Effect and X-Ray Observations," *The Astrophysical Journal*, 951, 41, 2023.
- Rose, Tom; Mcnamara, B. R.; Combes, F.; Edge, A. C.; Fabian, A. C.; Gaspari, M.; Russell, H.; Salomé, P.; Tremblay, G.; Ferland, G. "Does absorption against AGN reveal supermassive black hole accretion?," *Monthly Notices of the Royal Astronomical Society*, 518, 878, 2023.
- Roth, Jakob; Arras, Philipp; Reinecke, Martin; Perley, Richard A.; Westermann, Rüdiger; EnBlin, Torsten A. "Bayesian radio interferometric imaging with direction-dependent calibration," *Astronomy and Astrophysics*, 678, A177, 2023.
- Roth, Nathan X.; Milam, Stefanie N.; Disanti, Michael A.; Villanueva, Geronimo L.; Faggi, Sara; Bonev, Boncho P.; Cordiner, Martin A.; Remijan, Anthony J.; Bockelée-Morvan, Dominique; Biver, Nicolas; Crovisier, Jacques; Lis, Dariusz C.; Charnley, Steven B.; Jehin, Emmanuel; Wirstrom, Eva S.; Mckay, Adam J. "Molecular Outgassing in Centaur 29P/Schwassmann-Wachmann 1 during Its Exceptional 2021 Outburst: Coordinated Multiwavelength Observations Using nFLASH at APEX and iSHELL at the NASA-IRTF," *The Planetary Science Journal*, 4, 172, 2023.
- Roth, Nathan X.; Milam, Stefanie N.; Remijan, Anthony J.; Cordiner, Martin A.; Busch, Michael W.; Thomas, Cristina A.; Rivkin, Andrew S.; Moullet, Arielle; Roush, Ted L.; Siebert, Mark A.; Li, Jian-Yang; Fahnstock, Eugene G.; Trigo-Rodríguez, Josep M.; Opatom, Cyrielle; Hirabayashi, Masatoshi "ALMA Observations of the DART Impact: Characterizing the Ejecta at Submillimeter Wavelengths," *The Planetary Science Journal*, 4, 206, 2023.
- Rubio, A. C.; Carciofi, A. C.; Ticiani, P.; Mota, B. C.; Vieira, R. G.; Faes, D. M.; Genaro, M.; De Amorim, T. H.; Klement, R.; Araya, I.; Arcos, C.; Curé, M.; Domiciano De Souza, A.; Georgy, C.; Jones, C. E.; Suffak, M. W.; Silva, A. C. F. "Bayesian sampling with BeAtlas, a grid of synthetic Be star spectra I. Recovering the fundamental parameters of  $\alpha$  Eri and  $\beta$  CMi," *Monthly Notices of the Royal Astronomical Society*, 526, 3007, 2023.
- Rudnick, Lawrence; Cotton, W. D. "Full resolution deconvolution of complex Faraday spectra," *Monthly Notices of the Royal Astronomical Society*, 522, 1464, 2023.
- Ruffa, Ilaria; Davis, Timothy A.; Cappellari, Michele; Bureau, Martin; Elford, Jacob; Iguchi, Satoru; Lelli, Federico; Liang, Fu-Heng; Liu, Lijie; Lu, Anan; Sarzi, Marc; Williams, Thomas G. "WISDOM project - XIV. SMBH mass in the early-type galaxies NGC 0612, NGC 1574, and NGC 4261 from CO dynamical modelling," *Monthly Notices of the Royal Astronomical Society*, 522, 6170, 2023.
- Rujopakarn, Wiphu; Williams, Christina C.; Daddi, Emanuele; Schramm, Malte; Sun, Fengwu; Alberts, Stacey; Rieke, George H.; Tan, Qing-Hua; Tacchella, Sandro; Giavalisco, Mauro; Silverman, John D. "JWST and ALMA Imaging of Dust-obscured, Massive Substructures in a Typical  $z \sim 3$  Star-forming Disk Galaxy," *The Astrophysical Journal*, 948, L8, 2023.
- Rybak, M.; Van Marrewijk, J.; Hodge, J. A.; Andreati, P.; Calistro Rivera, G.; Graziani, L.; Mckean, J. P.; Viti, S.; Van Der Werf, P. P. "PRUSSIC. II. ALMA imaging of dense-gas tracers in SDP.81: Evidence for low mechanical heating and a sub-solar metallicity in a  $z = 3.04$  dusty galaxy," *Astronomy and Astrophysics*, 679, A119, 2023.
- Sabatini, Giovanni; Bovino, Stefano; Redaelli, Elena "First ALMA Maps of Cosmic-Ray Ionization Rate in High-mass Star-forming Regions," *The Astrophysical Journal*, 947, L18, 2023.
- Sahu, Dipen; Liu, Sheng-Yuan; Johnstone, Doug; Liu, Tie; Evans, Neal J.; Ii, Hirano, Naomi; Tatematsu, Ken'ichi; Di Francesco, James; Lee, Chin-Fei; Kim, Kee-Tae; Dutta, Somnath; Hsu, Shih-Ying; Li, Shanghuo; Luo, Qiu-Yi; Sanhueza, Patricio; Shang, Hsien; Traficante, Alessio; Juvela, Mika; Lee, Chang Won; Eden, David J.; Goldsmith, Paul F.; Bronfman, Leonardo; Kwon, Woojin; Lee, Jeong-Eun; Kuan, Yi-Jehng; Ristorcelli, Isabelle "ALMA Survey of Orion Planck Galactic Cold Clumps (ALMASOP): Density Structure of Centrally Concentrated Prestellar Cores from Multiscale Observations," *The Astrophysical Journal*, 945, 156, 2023.
- Sai, Jinshi (Insa Choi); Ohashi, Nagayoshi; Yen, Hsi-Wei; Maury, Anaëlle J.; Maret, Sébastien "Probing Velocity Structures of Protostellar Envelopes: Infalling and Rotating Envelopes within Turbulent Dense Cores," *The Astrophysical Journal*, 944, 222, 2023.
- Sai, Jinshi; Yen, Hsi-Wei; Ohashi, Nagayoshi; Tobin, John J.; Jørgensen, Jes K.; Takakuwa, Shigehisa; Saigo, Kazuya; Aso, Yusuke; Lin, Zhe-Yu Daniel; Koch, Patrick M.; Aikawa, Yuri; Flores, Christian; De Gregorio-Monsalvo, Itziar; Han, Ilseung; Kido, Miyu; Kwon, Woojin; Lai, Shih-Ping; Lee, Chang Won; Lee, Jeong-Eun; Li, Zhi-Yun; Looney, Leslie W.; Mori, Shoji; Phuong, Nguyen Thi; Santamaría-Miranda, Alejandro; Sharma, Rajeeb; Thieme, Travis J.; Tomida, Kengo; Williams, Jonathan P. "Early Planet Formation in Embedded Disks (eDisk). V. Possible Annular Substructure in a Circumstellar Disk in the Ced110 IRS4 System," *The Astrophysical Journal*, 954, 67, 2023.
- Saikia, Payaswini; Russell, David M.; Pirbhoy, Saarah F.; Baglio, M. C.; Bramich, D. M.; Alabarta, Kevin; Lewis, Fraser; Charles, Phil "Clockwise evolution in the hardness-intensity diagram of the black hole X-ray binary Swift J1910.2-0546," *Monthly Notices of the Royal Astronomical Society*, 524, 4543, 2023.
- Saldaña, H. P.; Rubio, M.; Bolatto, A. D.; Verdugo, C.; Jameson, K. E.; Leroy, A. K. "CO(2-1) survey at 9 pc resolution in the Small Magellanic Cloud," *Astronomy and Astrophysics*, 672, A153, 2023.
- Sanchez-Tovar, E.; Araya, E. D.; Rosero, V.; Hofner, P.; Kurtz, S. "Broadband VLA Spectral-line Survey of a Sample of Ionized Jet Candidates," *The Astrophysical Journal Supplement Series*, 267, 43, 2023.
- Sanders, Ryan L.; Shapley, Alice E.; Jones, Tucker; Shivaee, Irene; Popping, Gergö; Reddy, Naveen A.; Davé, Romeel; Price, Sedona H.; Mobasher, Bahram; Kriek, Mariska; Coil, Alison L.; Siana, Brian "CO Emission, Molecular Gas, and Metallicity in Main-sequence Star-forming Galaxies at  $z \sim 2.3$ ," *The Astrophysical Journal*, 942, 24, 2023.
- Sandstrom, Karin M.; Chasteney, Jérémy; Sutter, Jessica; Leroy, Adam K.;

- Egorov, Oleg V.; Williams, Thomas G.; Bolatto, Alberto D.; Boquien, M d ric; Cao, Yixian; Dale, Daniel A.; Lee, Janice C.; Rosolowsky, Erik; Schinnerer, Eva; Barnes, Ashley T.; Belfiore, Francesco; Bigiel, F.; Chevance, M lanie; Grasha, Kathryn; Groves, Brent; Hassani, Hamid; Hughes, Annie; Klessen, Ralf S.; Kruijssen, J. M. Diederik; Larson, Kirsten L.; Liu, Daizhong; Lopez, Laura A.; Meidt, Sharon E.; Murphy, Eric J.; Sormani, Mattia C.; Thilker, David A.; Watkins, Elizabeth J. "PHANGS-JWST First Results: Mapping the 3.3  $\mu\text{m}$  Polycyclic Aromatic Hydrocarbon Vibrational Band in Nearby Galaxies with NIRCcam Medium Bands," *The Astrophysical Journal*, 944, L7, 2023.
- Sandstrom, Karin M.; Koch, Eric W.; Leroy, Adam K.; Rosolowsky, Erik; Emsellem, Eric; Smith, Rowan J.; Egorov, Oleg V.; Williams, Thomas G.; Larson, Kirsten L.; Lee, Janice C.; Schinnerer, Eva; Thilker, David A.; Barnes, Ashley T.; Belfiore, Francesco; Bigiel, F.; Blanc, Guillermo A.; Bolatto, Alberto D.; Boquien, M d ric; Cao, Yixian; Chastenet, J r my; Chevance, M lanie; Chiang, I. -Da; Dale, Daniel A.; Faesi, Christopher M.; Glover, Simon C. O.; Grasha, Kathryn; Groves, Brent; Hassani, Hamid; Henshaw, Jonathan D.; Hughes, Annie; Kim, Jaeyeon; Klessen, Ralf S.; Kreckel, Kathryn; Kruijssen, J. M. Diederik; Lopez, Laura A.; Liu, Daizhong; Meidt, Sharon E.; Murphy, Eric J.; Pan, Hsi-An; Querejeta, Miguel; Saito, Toshiki; Sardone, Amy; Sormani, Mattia C.; Sutter, Jessica; Usero, Antonio; Watkins, Elizabeth J. "PHANGS-JWST First Results: Tracing the Diffuse Interstellar Medium with JWST Imaging of Polycyclic Aromatic Hydrocarbon Emission in Nearby Galaxies," *The Astrophysical Journal*, 944, L8, 2023.
- Sano, H.; Yamane, Y.; Van Loon, J. Th.; Furuya, K.; Fukui, Y.; Alsaberi, R. Z. E.; Bamba, A.; Enokiya, R.; Filipovi c, M. D.; Indebetouw, R.; Inoue, T.; Kawamura, A.; Laki evi c, M.; Law, C. J.; Mizuno, N.; Murase, T.; Onishi, T.; Park, S.; Plucinsky, P. P.; Rho, J.; Richards, A. M. S.; Rowell, G.; Sasaki, M.; Seok, J.; Sharda, P.; Staveley-Smith, L.; Suzuki, H.; Temim, T.; Tokuda, K.; Tsuge, K.; Tachihara, K. "ALMA Observations of Supernova Remnant N49 in the Large Magellanic Cloud. II. Non-LTE Analysis of Shock-heated Molecular Clouds," *The Astrophysical Journal*, 958, 53, 2023.
- Santa-Maria, M. G.; Goicoechea, J. R.; Pety, J.; Gerin, M.; Orkisz, J. H.; Le Petit, F.; Enig, L.; Palud, P.; De Souza Magalhaes, V.; Bešli c, I.; Segal, L.; Bardeau, S.; Bron, E.; Chainais, P.; Chanussot, J.; Gratier, P.; Guzm n, V. V.; Hughes, A.; Languignon, D.; Levrier, F.; Lis, D. C.; Liszt, H. S.; Le Bourlot, J.; Oya, Y.;  berg, K.; Peretto, N.; Roueff, E.; Roueff, A.; Sievers, A.; Thouvenin, P.-A.; Yamamoto, S. "HCN emission from translucent gas and UV-illuminated cloud edges revealed by wide-field IRAM 30 m maps of the Orion B GMC. Revisiting its role as a tracer of the dense gas reservoir for star formation," *Astronomy and Astrophysics*, 679, A4, 2023.
- Sato, Asako; Takahashi, Satoko; Ishii, Shun; Ho, Paul T. P.; Machida, Masahiro N.; Carpenter, John; A. Zapata, Luis; Teixeira, Paula Stella; Suri, S meyye "ALMA Fragmented Source Catalog in Orion (FraSCO). I. Outflow Interaction within an Embedded Cluster in OMC-2/FIR 3, FIR 4, and FIR 5," *The Astrophysical Journal*, 944, 92, 2023.
- Sato, Asako; Tokuda, Kazuki; Machida, Masahiro N.; Tachihara, Kengo; Harada, Naoto; Yamasaki, Hayao; Hirano, Shingo; Onishi, Toshikazu; Matsushita, Yuko "Secondary Outflow Driven by the Protostar Ser-emb 15 in Serpens," *The Astrophysical Journal*, 958, 102, 2023.
- Savolainen, T.; Giovannini, G.; Kovalev, Y. Y.; Perucho, M.; Anderson, J. M.; Bruni, G.; Edwards, P. G.; Fuentes, A.; Giroletti, M.; G mez, J. L.; Hada, K.; Lee, S.-S.; Lisakov, M. M.; Lobanov, A. P.; L pez-Mirallas, J.; Orienti, M.; Petrov, L.; Plavin, A. V.; Sohn, B. W.; Sokolovsky, K. V.; Voitsik, P. A.; Zensus, J. A. "RadioAstron discovery of a mini-cocoon around the restarted parsec-scale jet in 3C 84," *Astronomy and Astrophysics*, 676, A114, 2023.
- Schellenberger, Gerrit; O'Sullivan, Ewan; Giacintucci, Simona; Vrtilak, Jan; David, Laurence P.; Combes, Françoise; Birzan, Laura; Pan, Hsi-An; Lin, Lihwai "Feedback in the Extremely Violent Group Merger NGC 6338," *The Astrophysical Journal*, 948, 101, 2023.
- Schinnerer, Eva; Emsellem, Eric; Henshaw, Jonathan D.; Liu, Daizhong; Meidt, Sharon E.; Querejeta, Miguel; Renaud, Florent; Sormani, Mattia C.; Sun, Jiayi; Egorov, Oleg V.; Larson, Kirsten L.; Leroy, Adam K.; Rosolowsky, Erik; Sandstrom, Karin M.; Williams, T. G.; Barnes, Ashley T.; Bigiel, F.; Chevance, M lanie; Cao, Yixian; Chandar, Rupali; Dale, Daniel A.; Eibensteiner, Cosima; Glover, Simon C. O.; Grasha, Kathryn; Hannon, Stephen; Hassani, Hamid; Kim, Jaeyeon; Klessen, Ralf S.; Kruijssen, J. M. Diederik; Murphy, Eric J.; Neumann, Justus; Pan, Hsi-An; Pety, J r me; Saito, Toshiki; Stuber, Sophia K.; Tre , Robin G.; Usero, Antonio; Watkins, Elizabeth J.; Whitmore, Bradley C. "PHANGS-JWST First Results: Rapid Evolution of Star Formation in the Central Molecular Gas Ring of NGC 1365," *The Astrophysical Journal*, 944, L15, 2023.
- Scholtz, J.; Maiolino, R.; Jones, G. C.; Carniani, S. "Evidence of extended cold molecular gas and dust haloes around  $z \sim 2.3$  extremely red quasars with ALMA," *Monthly Notices of the Royal Astronomical Society*, 519, 5246, 2023.
- Schouws, Sander; Bouwens, Rychard; Smit, Renske; Hodge, Jacqueline; Stefanon, Mauro; Witstok, Joris; Hilhorst, Juliette; Labb , Ivo; Algera, Hiddo; Boogaard, Leindert; Maseda, Michael; Oesch, Pascal; R ttgering, Huub; Van Der Werf, Paul "ALMA as a Redshift Machine: Using [C II] to Efficiently Confirm Galaxies in the Epoch of Reionization," *The Astrophysical Journal*, 954, 103, 2023.
- Scibelli, Samantha; Shirley, Yancy; Schmiedeke, Anika; Svoboda, Brian; Singh, Ayushi; Lilly, James; Caselli, Paola "3D Radiative Transfer Modelling and Virial Analysis of Starless Cores in the B10 Region of the Taurus Molecular Cloud," *Monthly Notices of the Royal Astronomical Society*, 521, 4579, 2023.
- Scolati, Haley N.; Remijan, Anthony J.; Herbst, Eric; Mcguire, Brett A.; Lee, Kin Long Kelvin "Explaining the Chemical Inventory of Orion KL through Machine Learning," *The Astrophysical Journal*, 959, 108, 2023.
- Scoville, Nick; Faisst, Andreas; Weaver, John; Toft, Sune; Mccracken, Henry J.; Ilbert, Olivier; Diaz-Santos, Tania; Staguhn, Johannes; Koda, Jin; Casey, Caitlin; Sanders, David; Mobasher, Bahram; Chartab, Nima; Sattari, Zahra; Capak, Peter; Vanden Bout, Paul; Bongiorno, Angela; Vlahakis, Catherine; Sheth, Kartik; Yun, Min; Aussel, Herve; Laigle, Clotilde; Masters, Dan "Cosmic Evolution of Gas and Star Formation," *The Astrophysical Journal*, 943, 82, 2023.
- Sejake, Precious K.; White, Sarah V.; Heywood, Ian; Thorat, Kshitij; Bester, Hertzog L.; Makhathini, Sphehile; Fanaroff, Bernie "MeerKAT follow-up of enigmatic GLEAM 4-Jy (G4Jy) sources," *Monthly Notices of the Royal Astronomical Society*, 518, 4290, 2023.
- Sewilo, Marta; Tokuda, Kazuki; Kurtz, Stan E.; Charnley, Steven B.; M ller, Thomas; Wiseman, Jennifer; Chen, C. -H. Rosie; Indebetouw, Remy; S nchez-Monge,  lvaro; Tanaka, Kei E. I.; Schilke, Peter; Onishi, Toshikazu; Harada, Naoto "The Detection of Higher-order Millimeter Hydrogen Recombination Lines in the Large Magellanic Cloud," *The Astrophysical Journal*, 959, 22, 2023.
- Shanahan, Russell; Stil, Jeroen M.; Anderson, Loren; Beuther, Henrik; Goldsmith, Paul; Klessen, Ralf S.; Rugel, Michael; Soler, Juan D. "Turbulent Structure in Supernova Remnants G46.8-0.3 and G39.2-0.3 from THOR Polarimetry," *The Astrophysical Journal*, 957, 60, 2023.
- Shao, Xi; Gu, Minfeng; Chen, Yongjun; Yang, Hui; Yao, Su; Yuan, Weimin; Shen, Zhiqiang "The Radio Structure of the  $\gamma$ -Ray Narrow-line Seyfert 1 Galaxy SDSS J211852.96-073227.5," *The Astrophysical Journal*, 943, 136, 2023.
- Sharma, Anubhav; Masters, Karen L.; Stark, David V.; Garland, James; Drory, Niv; Weijmans, Anne-Marie "HI rich but low star formation galaxies in MaNGA: Physical properties and comparison to control samples," *Monthly Notices of the Royal Astronomical Society*, 526, 1573, 2023.
- Sharma, Rajeeb; J rgensen, Jes K.; Gavino, Sacha; Ohashi, Nagayoshi; Tobin, John J.; Lin, Zhe-Yu Daniel; Li, Zhi-Yun; Takakuwa, Shigehisa; Lee, Chang Won; Sai (Insa Choi), Jinshi; Kwon, Woojin; De Gregorio-Monsalvo, Itziar; Santamar a-Miranda, Alejandro; Yen, Hsi-Wei; Aikawa, Yuri; Aso, Yusuke; Lai, Shih-Ping; Lee, Jeong-Eun; Looney, Leslie W.; Phuong, Nguyen Thi; Thieme, Travis J.; Williams, Jonathan P. "Early Planet Formation in Embedded Disks (eDisk). IX. High-resolution

## APPENDIX A: PUBLICATIONS

- ALMA Observations of the Class 0 Protostar R CrA IRS5N and Its Surroundings," *The Astrophysical Journal*, 954, 69, 2023.
- Sheikh, Sofia Z.; Kanodia, Shubham; Lubar, Emily; Bowman, William P.; Cañas, Caleb I.; Gilbertson, Christian; Macdonald, Mariah G.; Wright, Jason; Macmahon, David; Croft, Steve; Price, Danny; Siemion, Andrew; Drew, Jamie; Worden, S. Pete; Trenholm, Elizabeth; The Breakthrough Listen Initiative "A Green Bank Telescope Search for Narrowband Technosignatures between 1.1 and 1.9 GHz During 12 Kepler Planetary Transits," *The Astronomical Journal*, 165, 61, 2023.
- Shimonishi, Takashi; Tanaka, Kei E. I.; Zhang, Yichen; Furuya, Kenji "The Detection of Hot Molecular Cores in the Small Magellanic Cloud," *The Astrophysical Journal*, 946, L41, 2023.
- Shivkumar, Hinna; Jaodand, Amruta D.; Balasubramanian, Arvind; Fremling, Christoffer; Corsi, Alessandra; Tzanidakis, Anastasios; Nissanke, Samaya; Kasliwal, Mansi; Brightman, Murray; Raaijmakers, Geert; Madsen, Kristin Kruse; Harrison, Fiona; Carbone, Dario; Nayana, A. J.; Désert, Jean-Michel; Andreoni, Igor "SN2019wxt: An Ultrastripped Supernova Candidate Discovered in the Electromagnetic Follow-up of a Gravitational Wave Trigger," *The Astrophysical Journal*, 952, 86, 2023.
- Shui, Qing C.; Zhang, S.; Chen, Yu P.; Zhang, Shuang N.; Kong, Ling D.; Wang, Peng J.; Ji, L.; Yin, Hong X.; Qu, Jin L.; Tao, L.; Ge, Ming Y.; Peng, Jing Q.; Chang, Z.; Li, J.; Zhang, P. "Tracing the Accretion Geometry of H1743-322 with Type C Quasiperiodic Oscillations in Multiple Outbursts," *The Astrophysical Journal*, 943, 165, 2023.
- Shu-Ting, Lin; Yu, Gao; Qing-Hua, Tan "Research on Physical Properties in NGC 1068 Nuclear Region Based on ALMA High-resolution Multi-spectral Lines," *Chinese Astronomy and Astrophysics*, 47, 586, 2023.
- Silpa, S.; Kharb, P.; Ho, Luis C.; Harrison, C. M. "Probing the Interplay between Jets, Winds, and Multi-phase Gas in 11 Radio-quiet PG Quasars: A uGMRT-VLA Study," *The Astrophysical Journal*, 958, 47, 2023.
- Simonte, M.; Andernach, H.; Brüggem, M.; Best, P. N.; Osinga, E. "Revisiting the alignment of radio galaxies in the ELAIS-N1 field," *Astronomy and Astrophysics*, 672, A178, 2023.
- Singal, Ashok K. "Discordance of dipole asymmetries seen in recent large radio surveys with the cosmological principle," *Monthly Notices of the Royal Astronomical Society*, 524, 3636, 2023.
- Singal, J.; Fornengo, N.; Regis, M.; Bernardi, G.; Bordenave, D.; Branchini, E.; Cappelluti, N.; Caputo, A.; Carucci, I. P.; Chluba, J.; Cuoco, A.; Dilullo, C.; Fialkov, A.; Hale, C.; Harper, S. E.; Heston, S.; Holder, G.; Kogut, A.; Krause, M. G. H.; Leahy, J. P.; Mittal, S.; Monsalve, R. A.; Piccirilli, G.; Pinetti, E.; Recchia, S.; Taoso, M.; Todarello, E. "The Second Radio Synchrotron Background Workshop: Conference Summary and Report," *Publications of the Astronomical Society of the Pacific*, 135, 36001, 2023.
- Singh, A. P.; Richards, A. M. S.; Humphreys, R. M.; Decin, L.; Ziurys, L. M. "ALMA Reveals Hidden Morphologies in the Molecular Envelope of VY Canis Majoris," *The Astrophysical Journal*, 954, L1, 2023.
- Singha, M.; Winkel, N.; Vaddi, S.; Perez Torres, M.; Gaspari, M.; Smirnova-Pinchukova, I.; O'Dea, C. P.; Combes, F.; Omoruyi, Osase; Rose, T.; Mcelroy, R.; Husemann, B.; Davis, T. A.; Baum, S. A.; Lawlor-Forsyth, C.; Neumann, J.; Tremblay, G. R. "The Close AGN Reference Survey (CARS): An Interplay between Radio Jets and AGN Radiation in the Radio-quiet AGN HE0040-1105," *The Astrophysical Journal*, 959, 107, 2023.
- Skeens, J.; York, J.; Petrov, L.; Munton, D.; Herrity, K.; Ji-Cathriner, R.; Bettadpur, S.; Gaussiran, T. "First Observations With a GNSS Antenna to Radio Telescope Interferometer," *Radio Science*, 58, e2023RS007734, 2023.
- Skokić, I.; Benz, A. O.; Brajša, R.; Sudar, D.; Matković, F.; Bárta, M. "Flares detected in ALMA single-dish images of the Sun," *Astronomy and Astrophysics*, 669, A156, 2023.
- Smith, D. A.; Abdollahi, S.; Ajello, M.; Bailes, M.; Baldini, L.; Ballet, J.; Baring, M. G.; Bassa, C.; Becerra Gonzalez, J.; Bellazzini, R.; Berretta, A.; Bhattacharyya, B.; Bissaldi, E.; Bonino, R.; Bottacini, E.; Bregeon, J.; Bruel, P.; Burgay, M.; Burnett, T. H.; Cameron, R. A.; Camilo, F.; Caputo, R.; Caraveo, P. A.; Cavazzuti, E.; Chiaro, G.; Ciprini, S.; Clark, C. J.; Cognard, I.; Corongiu, A.; Cristarella Orestano, P.; Crnogorčević, M.; Cuoco, A.; Cutini, S.; D'Ammando, F.; De Angelis, A.; Decesar, M. E.; De Gaetano, S.; De Menezes, R.; Deneva, J.; De Palma, F.; Di Lalla, N.; Dirisa, F.; Di Venere, L.; Domínguez, A.; Dumora, D.; Fegan, S. J.; Ferrara, E. C.; Fiori, A.; Fleischhack, H.; Flynn, C.; Frackowiak, A.; Freire, P. C. C.; Fukazawa, Y.; Fusco, P.; Galanti, G.; Gammaldi, V.; Gargano, F.; Gasparrini, D.; Giacchino, F.; Giglietto, N.; Giordano, F.; Giroletti, M.; Green, D.; Grenier, I. A.; Guillemot, L.; Guiriec, S.; Gustafsson, M.; Harding, A. K.; Hays, E.; Hewitt, J. W.; Horan, D.; Hou, X.; Jankowski, F.; Johnson, R. P.; Johnson, T. J.; Johnston, S.; Kataoka, J.; Keith, M. J.; Kerr, M.; Kramer, M.; Kuss, M.; Latronico, L.; Lee, S.-H.; Li, D.; Li, J.; Limyansky, B.; Longo, F.; Loparco, F.; Lorusso, L.; Lovellette, M. N.; Lower, M.; Lubrano, P.; Lyne, A. G.; Maan, Y.; Maldera, S.; Manchester, R. N.; Manfreda, A.; Marelli, M.; Marti-Devesa, G.; Mazzotta, M. N.; Mcenery, J. E.; Mereu, I.; Michelson, P. F.; Mickaliger, M.; Mitthumsiri, W.; Mizuno, T.; Moiseev, A. A.; Monzani, M. E.; Morselli, A.; Negro, M.; Nemmen, R.; Nieder, L.; Nuss, E.; Omodei, N.; Orienti, M.; Orlando, E.; Ormes, J. F.; Palatiello, M.; Paneque, D.; Panzarini, G.; Parthasarathy, A.; Persic, M.; Pesce-Rollins, M.; Pilleri, R.; Poon, H.; Porter, T. A.; Possenti, A.; Principe, G.; Rainò, S.; Rando, R.; Ransom, S. M.; Ray, P. S.; Razzano, M.; Razaque, S.; Reimer, A.; Reimer, O.; Renault-Tinacci, N.; Romani, R. W.; Sánchez-Conde, M.; Saz Parkinson, P. M.; Scotton, L.; Serini, D.; Sgrò, C.; Shannon, R.; Sharma, V.; Shen, Z.; Siskind, E. J.; Spandre, G.; Spinelli, P.; Stappers, B. W.; Stephens, T. E.; Suson, D. J.; Tabassum, S.; Tajima, H.; Tak, D.; Theureau, G.; Thompson, D. J.; Tibolla, O.; Torres, D. F.; Valverde, J.; Venter, C.; Wadiasingh, Z.; Wang, N.; Wang, N.; Wang, P.; Weltevredre, P.; Wood, K.; Yan, J.; Zaharijas, G.; Zhang, C.; Zhu, W. "The Third Fermi Large Area Telescope Catalog of Gamma-Ray Pulsars," *The Astrophysical Journal*, 958, 191, 2023.
- Smith, Krista Lynne; Magno, Macon; Tripathi, Ashutosh "The Nature of the IMBH Candidate CXO J133815.6+043255: High-frequency Radio Emission," *The Astrophysical Journal*, 956, 3, 2023.
- Smith, Simon E. T.; Friesen, Rachel; Marchal, Antoine; Pineda, Jaime E.; Caselli, Paola; Chen, Michael Chun-Yuan; Choudhury, Spandan; Di Francesco, James; Ginsburg, Adam; Kirk, Helen; Matzner, Chris; Punanova, Anna; Scibelli, Samantha; Shirley, Yancy "Velocity-coherent substructure in TMC-1: inflow and fragmentation," *Monthly Notices of the Royal Astronomical Society*, 519, 285, 2023.
- Snelders, M. P.; Nimmo, K.; Hessels, J. W. T.; Bensellam, Z.; Zwaan, L. P.; Chawla, P.; Ould-Boukattine, O. S.; Kirsten, F.; Faber, J. T.; Gajjar, V. "Detection of ultra-fast radio bursts from FRB 20121102A," *Nature Astronomy*, 7, 1486-1496, 2023.
- Sofue, Yoshiaki "Giant molecular cloud G181-0.3+51 associated with H II regions and supernova remnant in the 3-kpc expanding ring," *Monthly Notices of the Royal Astronomical Society*, 525, 4540, 2023.
- Sokolovsky, K. V.; Johnson, T. J.; Buson, S.; Jean, P.; Cheung, C. C.; Mukai, K.; Chomiuk, L.; Aydi, E.; Molina, B.; Kawash, A.; Linford, J. D.; Mioduszewski, A. J.; Rupen, M. P.; Sokolowski, J. L.; Williams, M. N.; Steinberg, E.; Vurm, I.; Metzger, B. D.; Page, K. L.; Orio, M.; Quimby, R. M.; Shafter, A. W.; Corbett, H.; Bolzoni, S.; Deyoung, J.; Menzies, K.; Romanov, F. D.; Richmond, M.; Ulowitz, J.; Vanmunster, T.; Williamson, G.; Lane, D. J.; Bartnik, M.; Bellaver, M.; Bruinsma, E.; Dugan, E.; Fedewa, J.; Gerhard, C.; Painter, S.; Peterson, D.-M.; Rodriguez, J. E.; Smith, C.; Sullivan, H.; Watson, S. "The multi-wavelength view of shocks in the fastest nova V1674 Her," *Monthly Notices of the Royal Astronomical Society*, 521, 5453, 2023.
- Somalwar, Jean J.; Ravi, Vikram; Dong, Dillon Z.; Chen, Yuyang; Breen, Shari; Chandra, Poonam; Clarke, Tracy; De, Kishalay; Gaensler, B. M.; Hallinan, Gregg; Laha, Sibasish; Law, Casey; Myers, Steven T.; Parsotan, Tyler; Peters, Wendy; Polisensky, Emil "A Candidate Relativistic Tidal Disruption Event at 340 Mpc," *The Astrophysical Journal*, 945, 142, 2023.
- Sormani, Mattia C.; Barnes, Ashley T.; Sun, Jiayi; Stuber, Sophia K.; Schinnerer, Eva; Emsellem, Eric; Leroy, Adam K.; Glover, Simon C. O.;



- Henshaw, Jonathan D.; Meidt, Sharon E.; Neumann, Justus; Querejeta, Miguel; Williams, Thomas G.; Bigiel, Frank; Eibensteiner, Cosima; Fragkoudi, Francesca; Levy, Rebecca C.; Grasha, Kathryn; Klessen, Ralf S.; Kruijssen, J. M. Diederik; Neumayer, Nadine; Pinna, Francesca; Rosolowsky, Erik W.; Smith, Rowan J.; Teng, Yu-Hsuan; Tress, Robin G.; Watkins, Elizabeth J. "Fuelling the nuclear ring of NGC 1097," *Monthly Notices of the Royal Astronomical Society*, 523, 2918, 2023.
- Spilker, Justin S.; Phadke, Kedar A.; Aravena, Manuel; Archipley, Melanie; Bayliss, Matthew B.; Birkin, Jack E.; Béthermin, Matthieu; Burgoyne, James; Cathey, Jared; Chapman, Scott C.; Dahle, Håkon; Gonzalez, Anthony H.; Gururajan, Gayathri; Hayward, Christopher C.; Hezaveh, Yashar D.; Hill, Ryley; Hutchison, Taylor A.; Kim, Keunho J.; Kim, Seonwoo; Law, David; Legin, Ronan; Malkan, Matthew A.; Marrone, Daniel P.; Murphy, Eric J.; Narayanan, Desika; Navarre, Alex; Olivier, Grace M.; Rich, Jeffrey A.; Rigby, Jane R.; Reuter, Cassie; Rhoads, James E.; Sharon, Keren; Smith, J. D. T.; Solimano, Manuel; Sulzenauer, Nikolaus; Vieira, Joaquin D.; Vizgan, David; Weiß, Axel; Whitaker, Katherine E. "Spatial variations in aromatic hydrocarbon emission in a dust-rich galaxy," *Nature*, 618, 708, 2023.
- Stadler, J.; Benisty, M.; Izquierdo, A.; Facchini, S.; Teague, R.; Kurtovic, N.; Pinilla, P.; Bae, J.; Ansdell, M.; Loomis, R.; Mayama, S.; Perez, L. M.; Testi, L. "A kinematically detected planet candidate in a transition disk," *Astronomy and Astrophysics*, 670, L1, 2023.
- Stanley, F.; Jones, B. M.; Riechers, D. A.; Yang, C.; Berta, S.; Cox, P.; Bakx, T. J. L. C.; Cooray, A.; Dannerbauer, H.; Dye, S.; Hughes, D. H.; Ivison, R. J.; Jin, S.; Lehnert, M.; Neri, R.; Omont, A.; Van Der Werf, P.; Weiss, A. "Resolved CO(1-0) Emission and Gas Properties in Luminous Dusty Star-forming Galaxies at  $z = 2-4$ ," *The Astrophysical Journal*, 945, 24, 2023.
- Stapper, L. M.; Hogerheijde, M. R.; Van Dishoeck, E. F.; Paneque-Carreño, T. "A dichotomy in group II Herbig disks. ALMA gas disk height measurements show both shadowed large vertically extended disks and compact flat disks," *Astronomy and Astrophysics*, 669, A158, 2023.
- Stein, M.; Heesen, V.; Dettmar, R.-J.; Stein, Y.; Brüggem, M.; Beck, R.; Adebahr, B.; Wiegert, T.; Vargas, C. J.; Bomans, D. J.; Li, J.; English, J.; Chyży, K. T.; Paladino, R.; Tabatabaei, F. S.; Strong, A. "CHANG-ES. XXVI. Insights into cosmic-ray transport from radio halos in edge-on galaxies," *Astronomy and Astrophysics*, 670, A158, 2023.
- Stephens, Ian W.; Lin, Zhe-Yu Daniel; Fernández-López, Manuel; Li, Zhi-Yun; Looney, Leslie W.; Yang, Haifeng; Harrison, Rachel; Kataoka, Akimasa; Carrasco-Gonzalez, Carlos; Okuzumi, Satoshi; Tazaki, Ryo "Aligned grains and scattered light found in gaps of planet-forming disk," *Nature*, 623, 705, 2023.
- Stevens, Adam R. H.; Brown, Toby; Diemer, Benedikt; Pillepich, Annalisa; Hernquist, Lars; Nelson, Dylan; Bahé, Yannick M.; Boselli, Alessandro; Davis, Timothy A.; Elahi, Pascal J.; Ellison, Sara L.; Jiménez-Donaire, María J.; Roberts, Ian D.; Spekkens, Kristine; Villanueva, Vicente; Watts, Adam B.; Wilson, Christine D.; Zabel, Nikki "VERTICO and IllustrisTNG: The Spatially Resolved Effects of Environment on Galactic Gas," *The Astrophysical Journal*, 957, L19, 2023.
- Stuber, Sophia K.; Schinnerer, Eva; Williams, Thomas G.; Querejeta, Miguel; Meidt, Sharon; Emsellem, Éric; Barnes, Ashley; Klessen, Ralf S.; Leroy, Adam K.; Neumann, Justus; Sormani, Mattia C.; Bigiel, Frank; Chevance, Mélanie; Dale, Danny; Faesi, Christopher; Glover, Simon C. O.; Grasha, Kathryn; Diederik Kruijssen, J. M.; Liu, Daizhong; Pan, Hsi-An; Pety, Jérôme; Pinna, Francesca; Saito, Toshiki; Usero, Antonio; Watkins, Elizabeth J. "The gas morphology of nearby star-forming galaxies," *Astronomy and Astrophysics*, 676, A113, 2023.
- Sturm, J. A.; Booth, A. S.; McClure, M. K.; Leemker, M.; Van Dishoeck, E. F. "Disentangling the protoplanetary disk gas mass and carbon depletion through combined atomic and molecular tracers," *Astronomy and Astrophysics*, 670, A12, 2023.
- Sturm, J. A.; McClure, M. K.; Beck, T. L.; Harsono, D.; Bergner, J. B.; Dartois, E.; Boogert, A. C. A.; Chiar, J. E.; Cordiner, M. A.; Drozdovskaya, M. N.; Ioppolo, S.; Law, C. J.; Linnartz, H.; Lis, D. C.; Melnick, G. J.; Mcguire, B. A.; Noble, J. A.; Öberg, K. I.; Palumbo, M. E.; Pendleton, Y. J.; Perotti, G.; Pontoppidan, K. M.; Qasim, D.; Rocha, W. R. M.; Terada, H.; Urso, R. G.; Van Dishoeck, E. F. "A JWST inventory of protoplanetary disk ices. The edge-on protoplanetary disk HH 48 NE, seen with the Ice Age ERS program," *Astronomy and Astrophysics*, 679, A138, 2023.
- Sturm, J. A.; McClure, M. K.; Law, C. J.; Harsono, D.; Bergner, J. B.; Dartois, E.; Drozdovskaya, M. N.; Ioppolo, S.; Öberg, K. I.; Palumbo, M. E.; Pendleton, Y. J.; Rocha, W. R. M.; Terada, H.; Urso, R. G. "The edge-on protoplanetary disk HH 48 NE. I. Modeling the geometry and stellar parameters," *Astronomy and Astrophysics*, 677, A17, 2023.
- Subrayan, Bhagya M.; Milisavljevic, Dan; Chornock, Ryan; Margutti, Raffaella; Alexander, Kate D.; Ramakrishnan, Vandana; Duffell, Paul C.; Dickinson, Danielle A.; Lee, Kyoung-Soo; Giannios, Dimitrios; Lentner, Geoffery; Linvill, Mark; Garretson, Braden; Graham, Matthew J.; Stern, Daniel; Brethauer, Daniel; Duong, Tien; Jacobson-Galán, Wynn; Lebaron, Natalie; Matthews, David; Sears, Huei; Venkatraman, Padma "Scary Barbie: An Extremely Energetic, Long-duration Tidal Disruption Event Candidate without a Detected Host Galaxy at  $z = 0.995$ ," *The Astrophysical Journal*, 948, L19, 2023.
- Sun, Haifeng; Yao, Dingkai; Shen, Lirong; Deng, Zhongwen; Bao, Weiming; Li, Xiaoping; Wang, Wencong; Zhou, Qingyong "Estimating 5-year rotation stability of PSR B1937+21 using NICER observations," *Acta Astronautica*, 210, 141, 2023.
- Sun, Jiayi; Leroy, Adam K.; Ostriker, Eve C.; Meidt, Sharon; Rosolowsky, Erik; Schinnerer, Eva; Wilson, Christine D.; Utomo, Dyas; Belfiore, Francesco; Blanc, Guillermo A.; Emsellem, Eric; Faesi, Christopher; Groves, Brent; Hughes, Annie; Koch, Eric W.; Kreckel, Kathryn; Liu, Daizhong; Pan, Hsi-An; Pety, Jérôme; Querejeta, Miguel; Razza, Alessandro; Saito, Toshiki; Sardone, Amy; Usero, Antonio; Williams, Thomas G.; Bigiel, Frank; Bolatto, Alberto D.; Chevance, Mélanie; Dale, Daniel A.; Gensior, Jindra; Glover, Simon C. O.; Grasha, Kathryn; Henshaw, Jonathan D.; Jiménez-Donaire, María J.; Klessen, Ralf S.; Kruijssen, J. M. Diederik; Murphy, Eric J.; Neumann, Lukas; Teng, Yu-Hsuan; Thilker, David A. "Star Formation Laws and Efficiencies across 80 Nearby Galaxies," *The Astrophysical Journal*, 945, L19, 2023.
- Sun, Ning-Chen; Maund, Justyn R.; Shao, Yali; Janiak, Ida A. "An environmental analysis of the fast transient AT2018cow and implications for its progenitor and late-time brightness," *Monthly Notices of the Royal Astronomical Society*, 519, 3785, 2023.
- Suresh, Akshay; Gajjar, Vishal; Nagarajan, Pranav; Sheikh, Sofia Z.; Siemion, Andrew P. V.; Lebofsky, Matt; Macmahon, David H. E.; Price, Danny C.; Croft, Steve "A 4-8 GHz Galactic Center Search for Periodic Technosignatures," *The Astronomical Journal*, 165, 255, 2023.
- Surgent, William Jeffrey; Lopez-Rodriguez, Enrique; Clark, Susan E. "The Structure of Magnetic Fields in Spiral Galaxies: A Radio and Far-infrared Polarimetric Analysis," *The Astrophysical Journal*, 954, 53, 2023.
- Suzuki, Taiki; Majumdar, Liton; Goldsmith, Paul F.; Tokuda, Kazuki; Minamoto, Harumi; Ohishi, Masatoshi; Saito, Masao; Hirota, Tomoya; Nomura, Hideko; Oya, Yoko "Survey of CH3NH2 and its Formation Process," *The Astrophysical Journal*, 954, 189, 2023.
- Suzuki, Tomoko L.; Van Mierlo, Sophie E.; Caputi, Karina I. "ALMA Millimeter/Submillimeter Sources among Spitzer SMUVS Galaxies at  $z > 2$  in the COSMOS Field," *The Astrophysical Journal*, 959, 82, 2023.
- Swiggum, J. K.; Pleunis, Z.; Parent, E.; Kaplan, D. L.; Mclaughlin, M. A.; Stairs, I. H.; Spiewak, R.; Agazie, G. Y.; Chawla, P.; Decesar, M. E.; Dolch, T.; Fiore, W.; Fonseca, E.; Istrate, A. G.; Kaspi, V. M.; Kondratiev, V. I.; Van Leeuwen, J.; Levin, L.; Lewis, E. F.; Lynch, R. S.; Mcewen, A. E.; Al Noori, H.; Ransom, S. M.; Siemens, X.; Surnis, M. "The Green Bank North Celestial Cap Survey. VII. 12 New Pulsar Timing Solutions," *The Astrophysical Journal*, 944, 154, 2023.
- Syed, J.; Beuther, H.; Goldsmith, P. F.; Henning, Th.; Heyer, M.; Klessen, R. S.; Stil, J. M.; Soler, J. D.; Anderson, L. D.; Urquhart, J. S.; Rugel, M. R.; Johnston, K. G.; Brunthaler, A. "Cold atomic gas identified by H I self-absorption. Cold atomic clouds toward giant molecular filaments," *Astronomy and Astrophysics*, 679, A130, 2023.
- Sylos Labini, Francesco; Straccamore, Matteo; De Marzo, Giordano;

## APPENDIX A: PUBLICATIONS

- Comerón, Sébastien "Mapping non-axisymmetric velocity fields of external galaxies," *Monthly Notices of the Royal Astronomical Society*, 524, 1560, 2023.
- Tadaki, Ken-Ichi; Kodama, Tadayuki; Koyama, Yusei; Suzuki, Tomoko L.; Mitsuhashi, Ikki; Ikeda, Ryota "Spatial Extent of Molecular Gas, Dust, and Stars in Massive Galaxies at  $z \sim 2.2$ -2.5 Determined with ALMA and JWST," *The Astrophysical Journal*, 957, L15, 2023.
- Tafoya, Daniel; Van Hoof, Peter A. M.; Toalá, Jesús A.; Van De Steene, Griet; Randall, Suzanna; Unnikrishnan, Ramlal; Kimeswenger, Stefan; Hajduk, Marcin; Barría, Daniela; Zijlstra, Albert "The heart of Sakurai's object revealed by ALMA," *Astronomy and Astrophysics*, 677, L8, 2023.
- Tahani, Mehrnoosh; Bastien, Pierre; Furuya, Ray S.; Pattle, Kate; Johnstone, Doug; Arzoumanian, Doris; Doi, Yasuo; Hasegawa, Tetsuo; Inutsuka, Shu-Ichiro; Coudé, Simon; Fissel, Laura; Chen, Michael Chun-Yuan; Poidevin, Frédéric; Sadavoy, Sarah; Friesen, Rachel; Koch, Patrick M.; Di Francesco, James; Moriarty-Schieven, Gerald H.; Chen, Zhiwei; Chung, Eun Jung; Eswarajah, Chakali; Fanciullo, Lapo; Gledhill, Tim; Le Gouellec, Valentin J. M.; Hoang, Thiem; Hwang, Jihye; Kang, Ji-Hyun; Kim, Kyoung Hee; Kirchschrager, Florian; Kwon, Woojin; Lee, Chang Won; Liu, Hong-Li; Onaka, Takashi; Rawlings, Mark G.; Soam, Archana; Tamura, Motohide; Tang, Xindi; Tomisaka, Kohji; Whitworth, Anthony P.; Kwon, Jungmi; Hoang, Thuong D.; Redman, Matt; Berry, David; Ching, Tao-Chung; Wang, Jia-Wei; Lai, Shih-Ping; Qiu, Keping; Ward-Thompson, Derek; Houde, Martin; Byun, Do-Young; Chen, Hui-Ru Vivien; Chen, Wen Ping; Cho, Jungyeon; Choi, Minh; Choi, Yunhee; Chrysostomou, Antonia; Diep, Pham Ngoc; Duan, Hao-Yuan; Fiege, Jason; Franzmann, Erica; Friberg, Per; Fuller, Gary; Graves, Sarah F.; Greaves, Jane S.; Griffin, Matt J.; Gu, Qilao; Han, Ilseung; Hatchell, Jennifer; Hayashi, Saeko S.; Hull, Charles L. H.; Inoue, Tsuyoshi; Iwasaki, Kazunari; Jeong, Il-Gyo; Kanamori, Yoshihiro; Kang, Miju; Kang, Sung-Ju; Kataoka, Akimasa; Kawabata, Koji S.; Kemper, Francisca; Kim, Gwanjeong; Kim, Jongsoo; Kim, Kee-Tae; Kim, Mi-Ryang; Kim, Shinyoung; Kirk, Jason M.; Kobayashi, Masato I. N.; Konyves, Vera; Kusune, Takayoshi; Lacaille, Kevin; Law, Chi-Yan; Lee, Chin-Fei; Lee, Hyeeseung; Lee, Jeong-Eun; Lee, Sang-Sung; Lee, Yong-Hee; Li, Dalei; Li, Di; Li, Hua-Bai; Liu, Junhao; Liu, Sheng-Yuan; Liu, Tie; De Looze, Ilse; Lyo, A. -Ran; Mairs, Steve; Matsumura, Masafumi; Matthews, Brenda C.; Nagata, Tetsuya; Nakamura, Fumitaka; Nakanishi, Hiroyuki; Ohashi, Nagayoshi; Park, Geumsook; Parsons, Harriet; Peretto, Nicolas; Pyo, Tae-Soo; Qian, Lei; Rao, Ramprasad; Retter, Brendan; Richer, John; Rigby, Andrew; Saito, Hiro; Savini, Giorgio; Scaife, Anna M. M.; Seta, Masumichi; Shimajiri, Yoshito; Shinnaga, Hiroko; Tang, Ya-Wen; Tsukamoto, Yusuke; Viti, Serena; Wang, Hongchi; Yen, Hsi-Wei; Yoo, Hyunju; Yuan, Jinghua; Yun, Hyeong-Sik; Zenko, Tetsuya; Zhang, Chuan-Peng; Zhang, Guoyin; Zhang, Yapeng; Zhou, Jianjun; Zhu, Lei; André, Philippe; Dowell, C. Darren; Eyres, Stewart P. S.; Falle, Sam; Van Loo, Sven; Robitaille, Jean-François "JCMT BISTRO Observations: Magnetic Field Morphology of Bubbles Associated with NGC 6334," *The Astrophysical Journal*, 944, 139, 2023.
- Takamura, Mieko; Hada, Kazuhiro; Honma, Mareki; Oyama, Tomoaki; Yamauchi, Aya; Suzuki, Syunsaku; Hagiwara, Yoshiaki; Orienti, Monica; D'Ammando, Filippo; Park, Jongho; Kam, Minchul; Doi, Akihiro "Probing the Heart of Active Narrow-line Seyfert 1 Galaxies with VERA Wideband Polarimetry," *The Astrophysical Journal*, 952, 47, 2023.
- Tamhane, Prathamesh D.; Mcnamara, Brian R.; Russell, Helen R.; Combes, Françoise; Qiu, Yu; Edge, Alastair C.; Maiolino, Roberto; Fabian, Andrew C.; Nulsen, Paul E. J.; Johnstone, R.; Carniani, Stefano "Radio jet-ISM interaction and positive radio-mechanical feedback in Abell 1795," *Monthly Notices of the Royal Astronomical Society*, 519, 3338, 2023.
- Tamura, Yoichi; C. Bakx, Tom J. L.; Inoue, Akio K.; Hashimoto, Takuya; Tokuoka, Tsuyoshi; Imamura, Chihiro; Hatsukade, Bunyo; Lee, Minju M.; Moriwaki, Kana; Okamoto, Takashi; Ota, Kazuaki; Umehata, Hideki; Yoshida, Naoki; Zackrisson, Erik; Hagimoto, Masato; Matsuo, Hiroshi; Shimizu, Ikkoh; Sugahara, Yuma; Takeuchi, Tsutomu T. "The 300 pc Resolution Imaging of a  $z = 8.31$  Galaxy: Turbulent Ionized Gas and Potential Stellar Feedback 600 Million Years after the Big Bang," *The Astrophysical Journal*, 952, 9, 2023.
- Tan, Wei Siang; Araya, Esteban D.; Rigg, Cade; Hofner, Peter; Kurtz, Stan; Linz, Hendrik; Rosero, Viviana "Excited Hydroxyl Outflow in the High-mass Star-forming Region G34.26 + 0.15," *The Astrophysical Journal*, 953, 90, 2023.
- Tang, Ya-Wen; Dutrey, Anne; Koch, Patrick M.; Guilloteau, Stéphane; Yen, Hsi-Wei; Di Folco, Emmanuel; Pantin, Eric; Muto, Takayuki; Kataoka, Akimasa; Brauer, Robert "Polarization in the GG Tau Ring-Confronting Dust Self-scattering, Dust Mechanical and Magnetic Alignment, Spirals, and Dust Grain Drift," *The Astrophysical Journal*, 947, L5, 2023.
- Taniguchi, Kotomi; Majumdar, Liton; Caselli, Paola; Takakuwa, Shigehisa; Hsieh, Tien-Hao; Saito, Masao; Li, Zhi-Yun; Dobashi, Kazuhito; Shimoikura, Tomomi; Nakamura, Fumitaka; Tan, Jonathan C.; Herbst, Eric "Chemical Differentiation around Five Massive Protostars Revealed by ALMA: Carbon-chain Species and Oxygen/Nitrogen-bearing Complex Organic Molecules," *The Astrophysical Journal Supplement Series*, 267, 4, 2023.
- Taniguchi, Kotomi; Sanhueza, Patricio; Olguin, Fernando A.; Gorai, Prasanta; Das, Ankan; Nakamura, Fumitaka; Saito, Masao; Zhang, Qizhou; Lu, Xing; Li, Shanguo; Chen, Hui-Ru Vivien "Digging into the Interior of Hot Cores with the ALMA (DIHCA). III. The Chemical Link between NH<sub>2</sub>CHO, HNCO, and H<sub>2</sub>CO," *The Astrophysical Journal*, 950, 57, 2023.
- Tarr, Lucas A.; Kobelski, Adam R.; Jaeggli, Sarah A.; Molnar, Momchil; Cauzzi, Gianna; Reardon, Kevin P. "Spatio-Temporal Comparisons of the Hydrogen-Alpha Line Width and ALMA 3 mm Brightness Temperature in the Weak Solar Network," *Frontiers in Astronomy and Space Sciences*, 9, 436, 2023.
- Temmink, M.; Booth, A. S.; Van Der Marel, N.; Van Dishoeck, E. F. "Investigating the asymmetric chemistry in the disk around the young star HD 142527," *Astronomy and Astrophysics*, 675, A131, 2023.
- Teng, Yu-Hsuan; Sandstrom, Karin M.; Sun, Jiayi; Gong, Munan; Bolatto, Alberto D.; Chiang, I-Da; Leroy, Adam K.; Usero, Antonio; Glover, Simon C. O.; Klessen, Ralf S.; Liu, Daizhong; Querejeta, Miguel; Schinnerer, Eva; Bigiel, Frank; Cao, Yixian; Chevance, Mélanie; Eibensteiner, Cosima; Grasha, Kathryn; Israel, Frank P.; Murphy, Eric J.; Neumann, Lukas; Pan, Hsi-An; Pinna, Francesca; Sormani, Mattia C.; Smith, J. D.; Walter, Fabian; Williams, Thomas G. "The Physical Drivers and Observational Tracers of CO-to-H<sub>2</sub> Conversion Factor Variations in Nearby Barred Galaxy Centers," *The Astrophysical Journal*, 950, 119, 2023.
- Tennis, Jessica D.; Xue, Ci; Talbi, Dahbia; Changala, P. Bryan; Sita, Madelyn L.; Mcguire, Brett; Herbst, Eric "Detection and modelling of CH<sub>3</sub>NC in TMC-1," *Monthly Notices of the Royal Astronomical Society*, 525, 2154-2171, 2023.
- Terada, Yuka; Liu, Haoyu Baobab; Mkrтчian, David; Sai, Jinshi; Konishi, Mihoko; Jiang, Ing-Guey; Muto, Takayuki; Hashimoto, Jun; Tamura, Motohide "Anisotropic Ionizing Illumination from an M-type Pre-main-sequence Star, DM Tau," *The Astrophysical Journal*, 953, 147, 2023.
- Terefe, Shimeles; Del Olmo, Ascensión; Marziani, Paola; Povič, Mirjana; Martínez-Carballo, María Angeles; Perea, Jaime; Márquez, Isabel "Optical and near-UV spectroscopic properties of low-redshift jetted quasars in the main sequence context," *Monthly Notices of the Royal Astronomical Society*, 525, 4474, 2023.
- Thieme, Travis J.; Lai, Shih-Ping; Ohashi, Nagayoshi; Tobin, John J.; Jørgensen, Jes K.; Sai, Jinshi (Insa Choi); Aso, Yusuke; Williams, Jonathan P.; Yamato, Yoshihide; Aikawa, Yuri; De Gregorio-Monsalvo, Itziar; Han, Ilseung; Kwon, Woojin; Lee, Chang Won; Lee, Jeong-Eun; Li, Zhi-Yun; Lin, Zhe-Yu Daniel; Looney, Leslie W.; Narayanan, Suchitra; Phuong, Nguyen Thi; Plunkett, Adele L.; Santamaría-Miranda, Alejandro; Sharma, Rajeeb; Takakuwa, Shigehisa; Yen, Hsi-Wei "Early Planet Formation in Embedded Disks (eDisk). VIII. A Small Protostellar Disk around the Extremely Low Mass and Young Class 0 Protostar IRAS 15398-3359," *The Astrophysical Journal*, 958, 60, 2023.
- Thomas, Cristina A.; Naidu, Shantanu P.; Scheirich, Peter; Moskovitz,

- Nicholas A.; Pravec, Petr; Chesley, Steven R.; Rivkin, Andrew S.; Osip, David J.; Lister, Tim A.; Benner, Lance A. M.; Brozović, Marina; Contreras, Carlos; Morrell, Nidia; Rožek, Agata; Kušnirák, Peter; Hornoch, Kamil; Mages, Declan; Taylor, Patrick A.; Seymour, Andrew D.; Snodgrass, Colin; Jørgensen, Uffe G.; Dominik, Martin; Skiff, Brian; Polakis, Tom; Knight, Matthew M.; Farnham, Tony L.; Giorgini, Jon D.; Rush, Brian; Bellerose, Julie; Salas, Pedro; Armentrout, William P.; Watts, Galen; Busch, Michael W.; Chatelain, Joseph; Gomez, Edward; Greenstreet, Sarah; Phillips, Liz; Bonavita, Mariangela; Burgdorf, Martin J.; Khalouei, Elahe; Longa-Peña, Penélope; Rabus, Markus; Sajadian, Sedighe; Chabot, Nancy L.; Cheng, Andrew F.; Ryan, William H.; Ryan, Eileen V.; Holt, Carrie E.; Agrusa, Harrison F. "Orbital period change of Dimorphos due to the DART kinetic impact," *Nature*, 616, 448, 2023.
- Thorne, Jessica E.; Robotham, Aaron S. G.; Bellstedt, Sabine; Davies, Luke J. M. "The long and the short of it: the benefits and leverage of ultraviolet-radio galaxy fitting," *Monthly Notices of the Royal Astronomical Society*, 522, 6354, 2023.
- Thygesen, Erica; Plotkin, Richard M.; Soria, Roberto; Reines, Amy E.; Greene, Jenny E.; Anderson, Gemma E.; Baldassare, Vivienne F.; Owens, Milo G.; Urquhart, Ryan T.; Gallo, Elena; Miller-Jones, James C. A.; Paul, Jeremiah D.; Rollings, Alexander P. "Multiwavelength scrutiny of X-ray sources in dwarf galaxies: ULXs versus AGNs," *Monthly Notices of the Royal Astronomical Society*, 519, 5848, 2023.
- Tinyanont, Samaporn; Woosley, Stan E.; Taggart, Kirsty; Foley, Ryan J.; Yan, Lin; Lunnan, Ragnhild; Davis, Kyle W.; Kilpatrick, Charles D.; Siebert, Matthew R.; Schulze, Steve; Ashall, Chris; Chen, Ting-Wan; De, Kishalay; Dimitriadis, Georgios; Dong, Dillon Z.; Fremling, Christoffer; Gagliano, Alexander; Jha, Saurabh W.; Jones, David O.; Kasliwal, Mansi M.; Miao, Hao-Yu; Pan, Yen-Chen; Perley, Daniel A.; Ravi, Vikram; Rojas-Bravo, César; Sfaradi, Itai; Sollerman, Jesper; Alarcon, Vanessa; Angulo, Rodrigo; Clever, Karoli E.; Crawford, Payton; Couch, Cirilla; Dandu, Srujan; Dhara, Atirath; Johnson, Jessica; Lai, Zhisen; Smith, Carli "Supernova 2020wnt: An Atypical Superluminous Supernova with a Hidden Central Engine," *The Astrophysical Journal*, 951, 34, 2023.
- Titov, Oleg; Frey, Sándor; Melnikov, Alexey; Shu, Fengchun; Xia, Bo; González, Javier; Tercero, Belén; Gurvits, Leonid; De Witt, Aletha; Mccallum, Jamie; Kharinov, Mikhail; Zimovsky, Vladimir; Krezinger, Máté "Astrometric Apparent Motion of High-redshift Radio Sources," *The Astronomical Journal*, 165, 69, 2023.
- Tiwari, Prabhakar; Zhao, Gong-Bo; Nusser, Adi "The Clustering Properties of AGNs/Quasars in CatWISE2020 Catalog," *The Astrophysical Journal*, 943, 116, 2023.
- To, Andy S. H.; James, Alexander W.; Bastian, T. S.; Van Driel-Gesztelyi, Lidia; Long, David M.; Baker, Deborah; Brooks, David H.; Lomuscio, Samantha; Stansby, David; Valori, Gherardo "Understanding the Relationship between Solar Coronal Abundances and F10.7 cm Radio Emission," *The Astrophysical Journal*, 948, 121, 2023.
- Tobin, John J.; Van'T Hoff, Merel L. R.; Leemker, Margot; Van Dishoeck, Ewine F.; Panique-Carreño, Teresa; Furuya, Kenji; Harsono, Daniel; Persson, Magnus V.; Cleeves, L. Ilse; Sheehan, Patrick D.; Cieza, Lucas "Deuterium-enriched water ties planet-forming disks to comets and protostars," *Nature*, 615, 227, 2023.
- Tokuda, Kazuki; Fukaya, Naofumi; Tachihara, Kengo; Omura, Mitsuki; Harada, Naoto; Nozaki, Shingo; Shoshi, Ayumu; Machida, Masahiro N. "An ALMA-resolved View of 7000 au Protostellar Gas Ring around the Class I Source CrA-IRS 2 as a Possible Sign of Magnetic Flux Advection," *The Astrophysical Journal*, 956, L16, 2023.
- Tokuda, Kazuki; Harada, Naoto; Tanaka, Kei E. I.; Inoue, Tsuyoshi; Shimonishi, Takashi; Zhang, Yichen; Sewiło, Marta; Kunitoshi, Yuri; Konishi, Ayu; Fukui, Yasuo; Kawamura, Akiko; Onishi, Toshikazu; Machida, Masahiro N. "An ALMA Glimpse of Dense Molecular Filaments Associated with High-mass Protostellar Systems in the Large Magellanic Cloud," *The Astrophysical Journal*, 955, 52, 2023.
- Toledano-Juárez, Iván; De La Fuente, Eduardo; Trinidad, Miguel A.; Tafuya, Daniel; Nigoche-Netro, Alberto "Collision of molecular outflows in the L1448-C system," *Monthly Notices of the Royal Astronomical Society*, 522, 1591, 2023.
- Tompkins, Scott A.; Driver, Simon P.; Robotham, Aaron S. G.; Windhorst, Rogier A.; Lagos, Claudia Del P.; Vernstrom, T.; Hopkins, Andrew M. "The cosmic radio background from 150 MHz to 8.4 GHz and its division into AGN and star-forming galaxy flux," *Monthly Notices of the Royal Astronomical Society*, 521, 332, 2023.
- Torne, Pablo; Liu, Kuo; Eatough, Ralph P.; Wongpecheausorn, Jompoj; Cordes, James M.; Desvignes, Gregory; De Laurentis, Mariafelicia; Kramer, Michael; Ransom, Scott M.; Chatterjee, Shami; Wharton, Robert; Karuppusamy, Ramesh; Blackburn, Lindy; Janssen, Michael; Chan, Chi-Kwan; Crew, Geoffrey, B.; Matthews, Lynn D.; Goddi, Ciriaco; Rottmann, Helge; Wagner, Jan; Sánchez, Salvador; Ruiz, Ignacio; Abbate, Federico; Bower, Geoffrey C.; Salamanca, Juan J.; Gómez-Ruiz, Arturo I.; Herrera-Aguilar, Alfredo; Jiang, Wu; Lu, Ru-Sen; Pen, Ue-Li; Raymond, Alexander W.; Shao, Lijing; Shen, Zhiqiang; Paubert, Gabriel; Sanchez-Portal, Miguel; Kramer, Carsten; Castillo, Manuel; Navarro, Santiago; John, David; Schuster, Karl-Friedrich; Johnson, Michael D.; Rygl, Kazi L. J.; Akiyama, Kazunori; Alberdi, Antxon; Alef, Walter; Algaba, Juan Carlos; Anantua, Richard; Asada, Keiichi; Azulay, Rebecca; Bach, Uwe; Baczo, Anne-Kathrin; Ball, David; Baloković, Mislav; Barrett, John; Bauböck, Michi; Benson, Bradford A.; Bintley, Dan; Blundell, Raymond; Bouman, Katherine L.; Boyce, Hope; Bremer, Michael; Brinkerink, Christiaan D.; Brissenden, Roger; Britzen, Silke; Broderick, Avery E.; Brogiere, Dominique; Bronzwaer, Thomas; Bustamante, Sandra; Byun, Do-Young; Carlstrom, John E.; Ceccobello, Chiara; Chael, Andrew; Chang, Dominic O.; Chatterjee, Koushik; Chen, Ming-Tang; Chen, Yongjun; Cheng, Xiaopeng; Cho, Ilje; Christian, Pierre; Conroy, Nicholas S.; Conway, John E.; Crawford, Thomas M.; Cruz-Osorio, Alejandro; Cui, Yuzhu; Dahale, Rohan; Davelaar, Jordy; Deane, Roger; Dempsey, Jessica; Dexter, Jason; Dhruv, Vedant; Doleman, Sheperd S.; Dougal, Sean; Dzib, Sergio A.; Emami, Razieh; Falcke, Heino; Farah, Joseph; Fish, Vincent L.; Fomalont, Ed; Ford, H. Alyson; Foschi, Marianna; Fraga-Encinas, Raquel; Freeman, William T.; Friberg, Per; Fromm, Christian M.; Fuentes, Antonio; Gaissner, Peter; Gammie, Charles F.; García, Roberto; Gentaz, Olivier; Georgiev, Boris; Gold, Roman; Gómez, José L.; Gu, Minfeng; Gurwell, Mark; Hada, Kazuhiro; Haggard, Daryl; Haworth, Kari; Hecht, Michael H.; Hesper, Ronald; Heumann, Dirk; Ho, Luis C.; Ho, Paul; Honma, Mareki; Huang, Chih-Wei L.; Huang, Lei; Hughes, David H.; Ikeda, Shiro; Impellizzeri, C. M. Violette; Inoue, Makoto; Issaoun, Sara; James, David J.; Jannuzi, Buell T.; Jeter, Britton; Jiménez-Rosales, Alejandra; Jorstad, Svetlana; Joshi, Abhishek V.; Jung, Taehyun; Karami, Mansour; Kawashima, Tomohisa; Keating, Garrett K.; Kettenis, Mark; Kim, Dong-Jin; Kim, Jae-Young; Kim, Jongsoo; Kim, Junhan; Kino, Motoki; Koay, Jun Yi; Kocherlakota, Prashant; Kofuji, Yutaro; Koyama, Shoko; Krichbaum, Thomas P.; Kuo, Cheng-Yu; La Bella, Noemi; Lauer, Tod R.; Lee, Daeyoung; Lee, Sang-Sung; Leung, Po Kin; Levis, Aviad; Li, Zhiyuan; Lico, Rocco; Lindahl, Greg; Lindqvist, Michael; Lisakov, Mikhail; Liu, Jun; Liuzzo, Elisabetta; Lo, Wen-Ping; Lobanov, Andrei P.; Loinard, Laurent; Lonsdale, Colin J.; Macdonald, Nicholas R.; Mao, Jirong; Marchili, Nicola; Markoff, Sera; Marrone, Daniel P.; Marscher, Alan P.; Martí-Vidal, Iván; Matsushita, Satoki; Medeiros, Lia; Menten, Karl M.; Michalik, Daniel; Mizuno, Izumi; Mizuno, Yosuke; Moran, James M.; Moriyama, Kotaro; Moscibrodzka, Monika; Müller, Cornelia; Müller, Hendrik; Mus, Alejandro; Musoke, Gibwa; Myserlis, Ioannis; Nadolski, Andrew; Nagai, Hiroshi; Nagar, Neil M.; Nakamura, Masanori; Narayan, Ramesh; Narayanan, Gopal; Natarajan, Iniyar; Nathanail, Antonios; Neilsen, Joey; Neri, Roberto; Ni, Chunghong; Noutsos, Aristeidis; Nowak, Michael A.; Oh, Junghwan; Okino, Hiroki; Olivares, Héctor; Ortiz-León, Gisela N.; Oyama, Tomoaki; Özel, Feryal; Palumbo, Daniel C. M.; Paraschos, Georgios Filippou; Park, Jongho; Parsons, Harriet; Patel, Nimesh; Pesce, Dominic W.; Piétu, Vincent; Plambeck, Richard; Popstefanija, Aleksandar; Porth, Oliver; Pötzl, Felix M.; Prather, Ben; Preciado-López, Jorge A.; Psaltis, Dimitrios; Pu, Hung-Yi; Ramakrishnan, Venkatesh; Rao, Ramprasad;

## APPENDIX A: PUBLICATIONS

- Rawlings, Mark G.; Rezzolla, Luciano; Ricarte, Angelo; Ripperda, Bart; Roelofs, Freek; Rogers, Alan; Ros, Eduardo; Romero-Cañizales, Cristina; Roshanineshat, Arash; Roy, Alan L.; Ruszczyk, Chet; Sánchez-Argüelles, David; Sasada, Mahito; Satapathy, Kaushik; Savolainen, Tuomas; Schloerb, F. Peter; Schonfeld, Jonathan; Small, Des; Sohn, Bong Won; Soohoo, Jason; Souccar, Kamal; Sun, He; Tetarenko, Alexandra J.; Tiede, Paul; Tilanus, Remo P. J.; Titus, Michael; Toscano, Teresa; Traianou, Eftalia; Trent, Tyler; Trippe, Sascha; Turk, Matthew; Van Bemmell, Ilse; Van Langevelde, Huib Jan; Van Rossum, Daniel R.; Vos, Jesse; Ward-Thompson, Derek; Wardle, John; Weintraub, Jonathan; Wex, Norbert; Wielgus, Maciek; Wiik, Kaj; Witzel, Gunther; Wondrak, Michael F.; Wong, George N.; Wu, Qingwen; Yadlapalli, Nitika; Yamaguchi, Paul; Yfantis, Aristomenis; Yoon, Doosoo; Young, André; Young, Ken; Younsi, Ziri; Yu, Wei; Yuan, Feng; Yuan, Ye-Fei; Zensus, J. Anton; Zhang, Shuo; Zhao, Guang-Yao; Zhao, Shan-Shan "A Search for Pulsars around Sgr A\* in the First Event Horizon Telescope Data Set," *The Astrophysical Journal*, 959, 14, 2023.
- Traficante, A.; Jones, B. M.; Avison, A.; Fuller, G. A.; Benedettini, M.; Elia, D.; Molinari, S.; Peretto, N.; Pezzuto, S.; Pillai, T.; Rygl, K. L. J.; Schisano, E.; Smith, R. J. "The SQUALO project (Star formation in QUIescent And Luminous Objects) I: clump-fed accretion mechanism in high-mass star-forming objects," *Monthly Notices of the Royal Astronomical Society*, 520, 2306, 2023.
- Trehaeven, K. S.; Parekh, V.; Oozeer, N.; Hugo, B.; Smirnov, O.; Bernardi, G.; Knowles, K.; Tasse, C.; Asad, K. M. B.; Giacintucci, S. "Mining Mini-Halos with MeerKAT I. Calibration and Imaging," *Monthly Notices of the Royal Astronomical Society*, 520, pp.4410-4426, 2023.
- Tripodi, Roberta; Feruglio, Chiara; Kemper, Francisca; Civano, Francesca; Costa, Tiago; Elvis, Martin; Bischetti, Manuela; Carniani, Stefano; Di Mascia, Fabio; D'Odorico, Valentina; Fiore, Fabrizio; Gallerani, Simona; Ginolfi, Michele; Maiolino, Roberto; Piconcelli, Enrico; Valiante, Rosa; Zappacosta, Luca "Accurate Dust Temperature and Star Formation Rate in the Most Luminous  $z > 6$  Quasar in the Hyperluminous Quasars at the Epoch of Reionization (HYPERION) Sample," *The Astrophysical Journal*, 946, L45, 2023.
- Tully, R. Brent; Kourkchi, Ehsan; Courtois, Hélène M.; Anand, Gagandeep S.; Blakeslee, John P.; Brout, Dillon; Jaeger, Thomas De; Dupuy, Alexandra; Guinet, Daniel; Howlett, Cullan; Jensen, Joseph B.; Pomarède, Daniel; Rizzi, Luca; Rubin, David; Said, Khaled; Scolnic, Daniel; Stahl, Benjamin E. "Cosmicflows-4," *The Astrophysical Journal*, 944, 94, 2023.
- Turner, Jacob E.; Stinebring, Daniel R.; McLaughlin, Maura A.; Archibald, Anne M.; Dolch, Timothy; Lynch, Ryan S. "Scattering Delay Mitigation in High-accuracy Pulsar Timing: Cyclic Spectroscopy Techniques," *The Astrophysical Journal*, 944, 191, 2023.
- Ubertosi, F.; Gitti, M.; Brighenti, F. "Chasing ICM cooling and AGN feedback from the macro to the meso scales in the galaxy cluster ZwCl 235," *Astronomy and Astrophysics*, 670, A23, 2023.
- Ubertosi, F.; Gitti, M.; Brighenti, F.; McDonald, M.; Nulsen, P.; Donahue, M.; Brunetti, G.; Randall, S.; Gaspari, M.; Etti, S.; Calzadilla, M.; Ignesti, A.; Feretti, L.; Blanton, E. L. "Multiple Shock Fronts in RBS 797: The Chandra Window on Shock Heating in Galaxy Clusters," *The Astrophysical Journal*, 944, 216, 2023.
- Ubertosi, F.; Gitti, M.; Brighenti, F.; Olivares, V.; O'Sullivan, E.; Schellenberger, G. "Waking the monster: The onset of AGN feedback in galaxy clusters hosting young central radio galaxies," *Astronomy and Astrophysics*, 673, A52, 2023.
- Ueda, Takahiro; Okuzumi, Satoshi; Kataoka, Akimasa; Flock, Mario "Probing the temperature structure of the inner region of a protoplanetary disk," *Astronomy and Astrophysics*, 675, A176, 2023.
- Uematsu, Ryosuke; Ueda, Yoshihiro; Kohno, Kotaro; Yamada, Satoshi; Toba, Yoshiki; Fujimoto, Seiji; Hatsukade, Bunyo; Umehata, Hideki; Espada, Daniel; Sun, Fengwu; Magdis, Georgios E.; Kokorev, Vasily; Ao, Yiping "ALMA Lensing Cluster Survey: Properties of Millimeter Galaxies Hosting X-Ray-detected Active Galactic Nuclei," *The Astrophysical Journal*, 945, 121, 2023.
- Ugwu, C. J.; Chibueze, J. O.; Morgan, J.; Csengeri, T.; Chukwude, A. E.; Van Der Walt, D. J.; Alhassan, J. A. "Probing gas kinematics towards the high-mass protostellar object G358.46-0.39," *Monthly Notices of the Royal Astronomical Society*, 520, 4747, 2023.
- Uno, Yuri; Hashimoto, Tetsuya; Goto, Tomotsugu; Ho, Simon C.-C.; Hsu, Tzu-Yin; Burns, Ross "Upper limits on transmitter rate of extragalactic civilizations placed by Breakthrough Listen observations," *Monthly Notices of the Royal Astronomical Society*, 522, 4649, 2023.
- Urata, Yuji; Toma, Kenji; Covino, Stefano; Wiersema, Klaas; Huang, Kuiyun; Shimoda, Jiro; Kuwata, Asuka; Nagao, Sota; Asada, Keiichi; Nagai, Hiroshi; Takahashi, Satoko; Chung, Chao-En; Petitpas, Glen; Yamaoka, Kazutaka; Izzo, Luca; Fynbo, Johan; De Ugarte Postigo, Antonio; Arabsalmani, Maryam; Tashiro, Makoto "Simultaneous radio and optical polarimetry of GRB 191221B afterglow," *Nature Astronomy*, 7, 80, 2023.
- Uscanga, L.; Imai, H.; Gómez, J. F.; Tafaya, D.; Orosz, G.; McCarthy, T. P.; Hamae, Y.; Amada, K. "Evolution of the Outflow in the Water Fountain Source IRAS 18043-2116," *The Astrophysical Journal*, 948, 17, 2023.
- Vagnozzi, Sunny "Inflationary interpretation of the stochastic gravitational wave background signal detected by pulsar timing array experiments," *Journal of High Energy Astrophysics*, 39, 81, 2023.
- Valdivia-Mena, M. T.; Pineda, J. E.; Segura-Cox, D. M.; Caselli, P.; Schmiedeke, A.; Choudhury, S.; Offner, S. S. R.; Neri, R.; Goodman, A.; Fuller, G. A. "Flow of gas detected from beyond the filaments to protostellar scales in Barnard 5★," *Astronomy and Astrophysics*, 677, A92, 2023.
- Van Der Vlugt, D.; Hodge, J. A.; Jin, S.; Algera, H. S. B.; Leslie, S. K.; Riechers, D. A.; Röttgering, H.; Smolčić, V.; Walter, F. "An Ultradeep Multiband Very Large Array Survey of the Faint Radio Sky (COSMOS-XS): New Constraints on the Optically Dark Population," *The Astrophysical Journal*, 951, 131, 2023.
- Van Kampen, Eelco; Lacy, Mark; Farrah, Duncan; Lagos, Claudia Del P.; Jarvis, Matt; Maraston, Claudia; Nyland, Kristina; Oliver, Seb; Surace, Jason; Thorne, Jessica "The Spitzer Extragalactic Representative Volume Survey and DeepDrill extension: clustering of near-infrared galaxies," *Monthly Notices of the Royal Astronomical Society*, 523, 251, 2023.
- Van Terwisga, S. E.; Hacar, A. "Survey of Orion Disks with ALMA (SODA). II. UV-driven disk mass loss in L1641 and L1647," *Astronomy and Astrophysics*, 673, L2, 2023.
- Van'T Hoff, Merel L. R.; Tobin, John J.; Li, Zhi-Yun; Ohashi, Nagayoshi; Jørgensen, Jes K.; Lin, Zhe-Yu Daniel; Aikawa, Yuri; Aso, Yusuke; De Gregorio-Monsalvo, Itziar; Gavino, Sacha; Han, Ilseung; Koch, Patrick M.; Kwon, Woojin; Lee, Chang Won; Lee, Jeong-Eun; Looney, Leslie W.; Narayanan, Suchitra; Plunkett, Adele; Sai Insa Choi, Jinshi; Santamaría-Miranda, Alejandro; Sharma, Rajeeb; Sheehan, Patrick D.; Takakuwa, Shigehisa; Thieme, Travis J.; Williams, Jonathan P.; Lai, Shih-Ping; Phuong, Nguyen Thi; Yen, Hsi-Wei "Early Planet Formation in Embedded Disks (eDisk). III. A First High-resolution View of Submillimeter Continuum and Molecular Line Emission toward the Class 0 Protostar L1527 IRS," *The Astrophysical Journal*, 951, 10, 2023.
- Vargas-González, J.; Forbrich, J.; Rivilla, V. M.; Menten, K. M.; Güdel, M.; Hacar, A. "A systematic survey of millimetre-wavelength flaring variability of young stellar objects in the Orion Nebula Cluster," *Monthly Notices of the Royal Astronomical Society*, 522, 56, 2023.
- Varglund, I.; Järvelä, E.; Ciroi, S.; Berton, M.; Congiu, E.; Lähteenmäki, A.; Di Mille, F. "A host galaxy study of southern narrow-line Seyfert 1 galaxies," *Astronomy and Astrophysics*, 679, A32, 2023.
- Vayner, Andrey; Zakamska, Nadia L.; Sabhlok, Sanchit; Wright, Shelley A.; Armus, Lee; Murray, Norman; Walth, Gregory; Ishikawa, Yuzo "Cold mode gas accretion on two galaxy groups at  $z \sim 2$ ," *Monthly Notices of the Royal Astronomical Society*, 519, 961, 2023.
- Vedantham, H. K.; Dupuy, T. J.; Evans, E. L.; Sanghi, A.; Callingham, J. R.; Shimwell, T. W.; Best, W. M. J.; Liu, M. C.; Zarka, P. "Polarised radio pulsations from a new T-dwarf binary," *Astronomy and Astrophysics*, 675, L6, 2023.
- Velilla-Prieto, L.; Fonfría, J. P.; Agúndez, M.; Castro-Carrizo, A.; Guélin, M.;

- Quintana-Lacaci, G.; Cherchneff, I.; Joblin, C.; Mccarthy, M. C.; Martín-Gago, J. A.; Cernicharo, J. "Atmospheric molecular blobs shape up circumstellar envelopes of AGB stars," *Nature*, 617, 696, 2023.
- Velović, Velibor; Cotton, William D.; Filipović, Miroslav D.; Norris, Ray P.; Barnes, Luke A.; Condon, James J. "MeerKAT view of the dancing ghosts - peculiar galaxy pair PKS 2130-538 in abell 3785," *Monthly Notices of the Royal Astronomical Society*, 523, 1933, 2023.
- Venkattu, Deepika; Lundqvist, Peter; Pérez Torres, Miguel; Morabito, Leah; Moldón, Javier; Conway, John; Chandra, Poonam; Tasse, Cyril "Subarcsecond-resolution Imaging of M51 with the International LOFAR Telescope," *The Astrophysical Journal*, 953, 157, 2023.
- Venturi, G.; Treister, E.; Finlez, C.; D'Ago, G.; Bauer, F.; Harrison, C. M.; Ramos Almeida, C.; Revalski, M.; Ricci, F.; Sartori, L. F.; Girdhar, A.; Keel, W. C.; Tubín, D. "Complex AGN feedback in the Teacup galaxy. A powerful ionised galactic outflow, jet-ISM interaction, and evidence for AGN-triggered star formation in a giant bubble," *Astronomy and Astrophysics*, 678, A127, 2023.
- Verma, Aayushi; Sharma, Saurabh; Mallick, Kshitiz K.; Dewangan, Lokesh; Ojha, Devendra K.; Yadav, Ram Kesh; Pandey, Rakesh; Ghosh, Arpan; Kaur, Harmeen; Panwar, Neelam; Chand, Tarak "Exploring Stellar Cluster and Feedback-driven Star Formation in the Galactic Mid-infrared Bubble [HKS2019] E70," *The Astrophysical Journal*, 953, 145, 2023.
- Veronese, Simone; De Blok, W. J. G.; Walter, F. "Extended neutral hydrogen filamentary network in NGC 2403," *Astronomy and Astrophysics*, 672, A55, 2023.
- Villar Martín, M.; Castro-Rodríguez, N.; Pereira Santaella, M.; Lamperti, I.; Tadhunter, C.; Emons, B.; Colina, L.; Alonso Herrero, A.; Cabrera-Lavers, A.; Bellocchi, E. "Limited impact of jet-induced feedback in the multi-phase nuclear interstellar medium of 4C12.50," *Astronomy and Astrophysics*, 673, A25, 2023.
- Villeneuve, M.; Podio, L.; Duchêne, G.; Stapelfeldt, K. R.; Melis, C.; Carrasco-Gonzalez, C.; Le Gouellec, V. J. M.; Ménard, F.; De Simone, M.; Chandler, C.; Garufi, A.; Pinte, C.; Bianchi, E.; Codella, C. "Modest Dust Settling in the IRAS04302+2247 Class I Protoplanetary Disk," *The Astrophysical Journal*, 946, 70, 2023.
- Vincentelli, F. M.; Neilsen, J.; Tetarenko, A. J.; Cavecchi, Y.; Castro Segura, N.; Del Palacio, S.; Van Den Eijnden, J.; Vasilopoulos, G.; Altamirano, D.; Armas Padilla, M.; Bailyn, C. D.; Belloni, T.; Buisson, D. J. K.; Cúneo, V. A.; Degenaar, N.; Knigge, C.; Long, K. S.; Jiménez-Ibarra, F.; Milburn, J.; Muñoz Darias, T.; Özbey Arabaci, M.; Remillard, R.; Russell, T. "A shared accretion instability for black holes and neutron stars," *Nature*, 615, 45, 2023.
- Vioque, Miguel; Cavieres, Manuel; González, Michelangelo Pantaleoni; Ribas, Álvaro; Oudmaijer, René D.; Mendigutía, Ignacio; Kilian, Lena; Cánovas, Héctor; Kuhn, Michael A. "Clustering Properties of Intermediate and High-mass Young Stellar Objects," *The Astronomical Journal*, 166, 183, 2023.
- Viveros, Harold E.; Masque, Josep M.; Trinidad, Miguel A.; De La Fuente, Eduardo "The ultracompact regions G40.54+2.59 and G34.13+0.47: A new detection of compact radio sources," *Publications of the Astronomical Society of Japan*, 75, 90, 2023.
- Vlemmings, W. H. T.; Tafaya, D. "Polarisation of molecular lines in the circumstellar envelope of the post-asymptotic giant branch star OH 17.7-2.0," *Astronomy and Astrophysics*, 671, A117, 2023.
- Vohl, D.; Vedantham, H. K.; Hessels, J. W. T.; Bassa, C. G.; Cook, D. O.; Kaplan, D. L.; Shimwell, T. W.; Zhang, C. "A LOFAR sample of luminous compact sources coincident with nearby dwarf galaxies," *Astronomy and Astrophysics*, 680, A98, 2023.
- Vollmer, B.; Soida, M.; Beck, R.; Kenney, J. D. P. "Deciphering the radio-star formation correlation on kpc scales. III. Radio-dim and bright regions in spiral galaxies," *Astronomy and Astrophysics*, 677, A104, 2023.
- Von Fellenberg, S. D.; Janssen, M.; Davelaar, J.; Zajaček, M.; Britzen, S.; Falcke, H.; Körding, E.; Ros, E. "Radio jet precession in M 81\*," *Astronomy and Astrophysics*, 672, L5, 2023.
- Wagenveld, J. D.; Klöckner, H.-R.; Gupta, N.; Deka, P. P.; Jagannathan, P.; Sekhar, S.; Balashev, S. A.; Boettcher, E.; Combes, F.; Emig, K. L.; Hilton, M.; Józsa, G. I. G.; Kamphuis, P.; Klutse, D. Y.; Knowles, K.; Krogager, J.-K.; Mohapatra, A.; Momjian, E.; Moodley, K.; Müller, S.; Petitjean, P.; Salas, P.; Sikhosana, S.; Srikanand, R. "The MeerKAT Absorption Line Survey: Homogeneous continuum catalogues towards a measurement of the cosmic radio dipole," *Astronomy and Astrophysics*, 673, A113, 2023.
- Waggoner, Abigail R.; Cleeves, L. Ilse; Loomis, Ryan A.; Aikawa, Yuri; Bae, Jaehan; Bergner, Jennifer B.; Booth, Alice S.; Calahan, Jenny K.; Cataldi, Gianni; Law, Charles J.; Le Gal, Romane; Long, Feng; Öberg, Karin I.; Teague, Richard; Wilner, David J. "MAPS: Constraining Serendipitous Time Variability in Protoplanetary Disk Molecular Ion Emission," *The Astrophysical Journal*, 956, 103, 2023.
- Walsh, Gregory; Burke-Spolaor, Sarah; Lazio, T. Joseph W. "A VLBI Proper Motion Analysis of the Recoiling Supermassive Black Hole Candidate Mrk 1018," *The Astrophysical Journal*, 952, 18, 2023.
- Wang, Ailing; An, Tao; Cheng, Xiaopeng; Ho, Luis C.; Kellermann, Kenneth I.; Baan, Willem A.; Yang, Jun; Zhang, Yingkang "VLBI observations of a sample of palomar-green quasars I: parsec-scale morphology," *Monthly Notices of the Royal Astronomical Society*, 518, 39, 2023.
- Wang, Ailing; An, Tao; Guo, Shaoguang; Ho, Luis C.; Baan, Willem A.; Braun, Robert; Chen, Sina; Cheng, Xiaopeng; Hartley, Philippa; Yang, Jun; Zhang, Yingkang "Mildly relativistic motion in the radio-quiet quasar PG 1351+640," *Monthly Notices of the Royal Astronomical Society*, 523, L30, 2023.
- Wang, Ailing; An, Tao; Guo, Shaoguang; Mohan, Prashanth; Chamani, Wara; Baan, Willem A.; Hovatta, Talvikki; Falcke, Heino; Galvin, Tim J.; Hurley-Walker, Natasha; Jaiswal, Sumit; Lahteenmaki, Anne; Lao, Baoqiang; Lv, Weijia; Tornikoski, Merja; Zhang, Yingkang "Interactions between the Jet and Disk Wind in Nearby Radio-intermediate Quasar III Zw 2," *The Astrophysical Journal*, 944, 187, 2023.
- Wang, Ailing; An, Tao; Zhang, Yingkang; Cheng, Xiaopeng; Ho, Luis C.; Kellermann, Kenneth I.; Baan, Willem A. "VLBI Observations of a sample of Palomar-Green quasars II: characterizing the parsec-scale radio emission," *Monthly Notices of the Royal Astronomical Society*, 525, 6064, 2023.
- Wang, Ailing; Peng, Yingjie "The Kinematic Bimodality: Efficient Feedback and Cold Gas Deficiency in Slow-rotating Galaxies," *The Astrophysical Journal*, 950, L22, 2023.
- Wang, Chao; Wang, Ke "Highly structured turbulence in high-mass star formation: An evolved infrared-dark cloud G35.20-0.74 N," *Astronomy and Astrophysics*, 674, A46, 2023.
- Wang, Gan; Lu, Ru-Sen; Shen, Zhi-Qiang; Jiang, Wu; Huang, Lei; Zhao, Shan-Shan; Yan, Xi; Yuan, Cheng "High Resolution Observation Study of S4 0954+65 Radio Jet," *Progress in Astronomy*, 41, 257, 2023.
- Wang, Hongtao; Guo, Chao; Cao, Hongmin; Chen, Yongyun; Ding, Nan; Guo, Xiaotong "The comparison of optical variability of broad-line Seyfert 1 and narrow-line Seyfert 1 galaxies from the view of Pan-STARRS," *Astrophysics and Space Science*, 368, 68, 2023.
- Wang, Junzhi; Shi, Yong; Zhang, Zhi-Yu; Liu, Shu; Gao, Yu; Zhang, Jiangshui; Zhu, Fengyao; Fang, Min "Non-detection of broad hydrogen radio recombination lines in the Circinus galaxy," *Monthly Notices of the Royal Astronomical Society*, 518, L36, 2023.
- Wang, Lixin; Wang, Hongjun; Liu, Bin; Armentrout, Will "Non-LTE Radio Recombination Line Analysis towards H II Region G34.25+0.14," *Monthly Notices of the Royal Astronomical Society*, 526, 423-428, 2023.
- Wang, Xuezheng; Jiang, Wu; Shen, Zhiqiang; Yan, Zhen; Li, Ya-Ping; Martí-Vidal, Ivan; Gold, Roman "Detection of a 0.1c Radio Knot in M81\* Associated with a Moderate X-Ray Flare," *The Astrophysical Journal*, 957, 107, 2023.
- Wang, Yanan; Baldi, Ranieri D.; Del Palacio, Santiago; Guolo, Muryel; Yang, Xiaolong; Zhang, Yangkang; Done, Chris; Castro Segura, Noel; Pasham, Dheeraj R.; Middleton, Matthew; Altamirano, Diego; Gandhi, Poshak; Qiao, Erlin; Jiang, Ning; Yan, Hongliang; Giroletti, Marcello;

## APPENDIX A: PUBLICATIONS

- Migliori, Giulia; Mchardy, Ian; Panessa, Francesca; Jin, Chichuan; Shen, Rongfeng; Dai, Lixin "The radio detection and accretion properties of the peculiar nuclear transient AT 2019avd," *Monthly Notices of the Royal Astronomical Society*, 520, 2417, 2023.
- Wang, Yi-Ying; Tang, Shao-Peng; Jin, Zhi-Ping; Fan, Yi-Zhong "The Late Afterglow of GW170817/GRB 170817A: A Large Viewing Angle and the Shift of the Hubble Constant to a Value More Consistent with the Local Measurements," *The Astrophysical Journal*, 943, 13, 2023.
- Wang, Yu-Bin; Kurban, Abdusattar; Zhou, Xia; Yu, Yun-Wei; Wang, Na "Statistical properties and lensing effect on the repeating fast radio burst FRB 180916.J0158+65," *Monthly Notices of the Royal Astronomical Society*, 524, 569, 2023.
- Ward-Thompson, Derek; Karoly, Janik; Pattle, Kate; Whitworth, Anthony; Kirk, Jason; Berry, David; Bastien, Pierre; Ching, Tao-Chung; Coudé, Simon; Hwang, Jihye; Kwon, Woonjin; Soam, Archana; Wang, Jia-Wei; Hasegawa, Tetsuo; Lai, Shih-Ping; Qiu, Keping; Arzoumanian, Doris; Bourke, Tyler L.; Byun, Do-Young; Chen, Huei-Ru Vivien; Chen, Wen Ping; Chen, Mike; Chen, Zhiwei; Cho, Jungyeon; Choi, Minho; Choi, Youngwoo; Choi, Yunhee; Chrysostomou, Antonio; Chung, Eun Jung; Dai, Sophia; Debattista, Victor; Di Francesco, James; Diep, Pham Ngoc; Doi, Yasuo; Duan, Hao-Yuan; Duan, Yan; Eswaraiah, Chakali; Fanciullo, Lapo; Fiege, Jason; Fissel, Laura M.; Franzmann, Erica; Friberg, Per; Friesen, Rachel; Fuller, Gary; Furuya, Ray; Gledhill, Tim; Graves, Sarah; Greaves, Jane; Griffin, Matt; Gu, Qilao; Han, Ilseung; Hayashi, Saeko; Hoang, Thiem; Houde, Martin; Hull, Charles L. H.; Inoue, Tsuyoshi; Inutsuka, Shu-Ichiro; Iwasaki, Kazunari; Jeong, Il-Gyo; Johnstone, Doug; Könyves, Vera; Kang, Ji-Hyun; Kang, Miju; Kataoka, Akimasa; Kawabata, Koji; Kemper, Francisca; Kim, Jongsoo; Kim, Shinyoung; Kim, Gwanjeong; Kim, Kyoung Hee; Kim, Mi-Ryang; Kim, Kee-Tae; Kim, Hyosung; Kirchschrager, Florian; Kobayashi, Masato I. N.; Koch, Patrick M.; Kusune, Takayoshi; Kwon, Jungmi; Lacaille, Kevin; Law, Chi-Yan; Lee, Chang Won; Lee, Hyeonseung; Lee, Yong-Hee; Lee, Chin-Fei; Lee, Jeong-Eun; Lee, Sang-Sung; Li, Dalei; Li, Di; Li, Guangxing; Li, Hua-Bai; Lin, Sheng-Jun; Liu, Hong-Li; Liu, Tie; Liu, Sheng-Yuan; Liu, Junhao; Longmore, Steven; Lu, Xing; Lyo, A. -Ran; Mairs, Steve; Matsumura, Masafumi; Matthews, Brenda; Moriarty-Schieven, Gerald; Nagata, Tetsuya; Nakamura, Fumitaka; Nakanishi, Hiroyuki; Ngoc, Nguyen Bich; Ohashi, Nagayoshi; Onaka, Takashi; Park, Geumsook; Parsons, Harriet; Peretto, Nicolas; Priestley, Felix; Pyo, Tae-Soo; Qian, Lei; Rao, Ramprasad; Rawlings, Jonathan; Rawlings, Mark; Retter, Brendan; Richer, John; Rigby, Andrew; Sadavoy, Sarah; Saito, Hiro; Savini, Giorgio; Seta, Masumichi; Shimajiri, Yoshito; Shinnaga, Hiroko; Tahani, Mehrnoosh; Tamura, Motohide; Tang, Ya-Wen; Tang, Xindi; Tomisaka, Kohji; Tram, Le Ngoc; Tsukamoto, Yusuke; Viti, Serena; Wang, Hongchi; Wu, Jintai; Xie, Jinjin; Yang, Meng-Zhe; Yen, Hsi-Wei; Yoo, Hyunju; Yuan, Jinghua; Yun, Hyeong-Sik; Zenko, Tetsuya; Zhang, Guoyin; Zhang, Yapeng; Zhang, Chuan-Peng; Zhou, Jianjun; Zhu, Lei; De Looze, Ilse; André, Philippe; Dowell, C. Darren; Eden, David; Eyres, Stewart; Falle, Sam; Le Gouellec, Valentin J. M.; Poidevin, Frédéric; Robitaille, Jean-François; Van Loo, Sven "First BISTRO Observations of the Dark Cloud Taurus L1495A-B10: The Role of the Magnetic Field in the Earliest Stages of Low-mass Star Formation," *The Astrophysical Journal*, 946, 62, 2023.
- Watkins, E. J.; Kreckel, K.; Groves, B.; Glover, S. C. O.; Whitmore, B. C.; Leroy, A. K.; Schinnerer, E.; Meidt, S. E.; Egorov, O. V.; Barnes, A. T.; Lee, J. C.; Bigiel, F.; Boquien, M.; Chandar, R.; Chevance, M.; Dale, D. A.; Grasha, K.; Klessen, R. S.; Kruijssen, J. M. D.; Larson, K. L.; Li, J.; Méndez-Delgado, J. E.; Pessa, I.; Saito, T.; Sanchez-Blazquez, P.; Sarbadhichary, S. K.; Scheuermann, F.; Thilker, D. A.; Williams, T. G. "Quantifying the energetics of molecular superbubbles in PHANGS galaxies," *Astronomy and Astrophysics*, 676, A67, 2023.
- Watts, Adam B.; Cortese, Luca; Catinella, Barbara; Brown, Toby; Wilson, Christine D.; Zabel, Nikki; Roberts, Ian D.; Davis, Timothy A.; Thorp, Mallory; Chung, Aeree; Stevens, Adam R. H.; Ellison, Sara L.; Spekkens, Kristine; Parker, Laura C.; Bahé, Yannick M.; Villanueva, Vicente; Jiménez-Donaire, María; Bisaria, Dhruv; Boselli, Alessandro; Bolatto, Alberto D.; Lee, Bumhyun "VERTICO V: The environmentally driven evolution of the inner cold gas discs of Virgo cluster galaxies," *Publications of the Astronomical Society of Australia*, 40, e017, 2023.
- Weber, Philipp; Pérez, Sebastián; Zurlo, Alice; Miley, James; Hales, Antonio; Cieza, Lucas; Principe, David; Cárcamo, Miguel; Garufi, Antonio; Kóspál, Ágnes; Takami, Michihiro; Kastner, Joel; Zhu, Zhaohuan; Williams, Jonathan "Spirals and Clumps in V960 Mon: Signs of Planet Formation via Gravitational Instability around an FU Ori Star?," *The Astrophysical Journal*, 952, L17, 2023.
- Whitcomb, C. M.; Sandstrom, K.; Leroy, A.; Smith, J. -D. T. "Star Formation and Molecular Gas Diagnostics with Mid- and Far-infrared Emission," *The Astrophysical Journal*, 948, 88, 2023.
- White, Jack; Adámek, Karel; Roy, Jayanta; Dimoudi, Sofia; Ransom, Scott M.; Armour, Wesley "Bits Missing: Finding Exotic Pulsars Using bfloat16 on NVIDIA GPUs," *The Astrophysical Journal Supplement Series*, 265, 13, 2023.
- Whitmore, Bradley C.; Chandar, Rupali; Lee, Janice C.; Floyd, Matthew; Deger, Sinan; Lilly, James; Minsley, Rebecca; Thilker, David A.; Boquien, Médéric; Dale, Daniel A.; Henny, Kiana; Scheuermann, Fabian; Barnes, Ashley T.; Bigiel, Frank; Emsellem, Eric; Glover, Simon; Grasha, Kathryn; Groves, Brent; Hannon, Stephen; Klessen, Ralf S.; Kreckel, Kathryn; Kruijssen, J. M. Diederik; Larson, Kirsten L.; Leroy, Adam; Mok, Angus; Pan, Hsi-An; Pinna, Francesca; Sánchez-Blázquez, Patricia; Schinnerer, Eva; Sormani, Mattia C.; Watkins, Elizabeth; Williams, Thomas "Improving Star Cluster Age Estimates in PHANGS-HST Galaxies and the Impact on Cluster Demographics in NGC 628," *Monthly Notices of the Royal Astronomical Society*, 520, 63, 2023.
- Wilensky, Michael J.; Kennedy, Fraser; Bull, Philip; Dillon, Joshua S.; Abdurashidova, Zara; Adams, Tyrone; Aguirre, James E.; Alexander, Paul; Ali, Zaki S.; Baartman, Rushelle; Balfour, Yanga; Beardsley, Adam P.; Bernardi, Gianni; Billings, Tashalee S.; Bowman, Judd D.; Bradley, Richard F.; Burba, Jacob; Carey, Steven; Carilli, Chris L.; Cheng, Carina; Deboer, David R.; De Lera Acedo, Eloy; Dexter, Matt; Eksteen, Nico; Ely, John; Ewall-Wice, Aaron; Fagnoni, Nicolas; Fritz, Randall; Furlanetto, Steven R.; Gale-Sides, Kingsley; Glendenning, Brian; Gorthi, Deepthi; Greig, Bradley; Grobbelaar, Jasper; Haldaj, Ziyaad; Hazelton, Bryna J.; Hewitt, Jacqueline N.; Hickish, Jack; Jacobs, Daniel C.; Julius, Austin; Kariseb, Maccalvin; Kern, Nicholas S.; Kerrigan, Joshua; Kittiwisit, Piyanat; Kohn, Saul A.; Kolopanis, Matthew; Lanman, Adam; La Plante, Paul; Liu, Adrian; Loots, Anita; Macmahon, David Harold Edward; Malan, Lourence; Malgas, Cresshim; Malgas, Keith; Marero, Bradley; Martinot, Zachary E.; Mesinger, Andrei; Molewa, Mathakane; Morales, Miguel F.; Mosiane, Tshogofalang; Murray, Steven G.; Neben, Abraham R.; Nikolic, Bojan; Nuwegeld, Hans; Parsons, Aaron R.; Patra, Nipanjana; Pieterse, Samantha; Razavi-Ghods, Nima; Robnett, James; Rosie, Kathryn; Sims, Peter; Swarts, Hilton; Thyagarajan, Nithyanandan; Van Wyngaarden, Pieter; Williams, Peter K. G.; Zheng, Haoxuan "Bayesian jackknife tests with a small number of subsets: application to HERA 21 cm power spectrum upper limits," *Monthly Notices of the Royal Astronomical Society*, 518, 6041, 2023.
- Wilkins, Olivia H.; Blake, Geoffrey A. "New interstellar laboratories in the molecular ring," *Faraday Discussions*, 245, 138, 2023.
- Williams, Becky J.; Cleeves, L. Ilseadore; Eistrup, Christian; Ramsey, Jon P. "Deep Search for Molecular Oxygen in TW Hya," *The Astrophysical Journal*, 956, 135, 2023.
- Williams, G. M.; Cyganowski, C. J.; Brogan, C. L.; Hunter, T. R.; Nazari, P.; Smith, R. J. "ALMA observations of the Extended Green Object G19.01-0.03 - II. A massive protostar with typical chemical abundances surrounded by four low-mass pre-stellar core candidates," *Monthly Notices of the Royal Astronomical Society*, 525, 6146, 2023.
- Williams, Thomas G.; Bureau, Martin; Davis, Timothy A.; Cappellari, Michele; Choi, Woora; Elford, Jacob S.; Iguchi, Satoru; Gensior, Jindra; Liang, Fu-Heng; Lu, Anan; Ruffa, Ilaria; Zhang, Hengyue "WISDOM Project - XVII. Beam-by-beam properties of the molecular gas in early-type

- galaxies," *Monthly Notices of the Royal Astronomical Society*, 525, 4270, 2023.
- Willmer, Christopher N. A.; Ly, Chun; Kikuta, Satoshi; Kattner, S. A.; Jansen, Rolf A.; Cohen, Seth H.; Windhorst, Rogier A.; Smail, Ian; Tompkins, Scott; Beacom, John F.; Cheng, Cheng; Conselice, Christopher J.; Frye, Brenda L.; Koekemoer, Anton M.; Hathi, Nimish; Hyun, Minhee; Im, Myungshin; Willner, S. P.; Zhao, X.; Briske, Walter A.; Civano, F.; Cotton, William; Hasinger, Günther; Maksym, W. Peter; Rieke, Marcia J.; Grogin, Norman A. "PEARLS: Near-infrared Photometry in the JWST North Ecliptic Pole Time Domain Field," *The Astrophysical Journal Supplement Series*, 269, 21, 2023.
- Willner, S. P.; Gim, Hansung B.; Del Carmen Polletta, Maria; Cohen, Seth H.; Willmer, Christopher N. A.; Zhao, Xiurui; D'Silva, Jordan C. J.; Jansen, Rolf A.; Koekemoer, Anton M.; Summers, Jake; Windhorst, Rogier A.; Coe, Dan; Conselice, Christopher J.; Driver, Simon P.; Frye, Brenda; Grogin, Norman A.; Marshall, Madeline A.; Nonino, Mario; Ortiz, Rafael; Pirzkal, Nor; Robotham, Aaron; Rutkowski, Michael J.; Ryan, Russell E.; Tompkins, Scott; Yan, Haojing; Hammel, Heidi B.; Milam, Stefanie N.; Adams, Nathan J.; Beacom, John F.; Bhatawdekar, Rachana; Cheng, Cheng; Civano, F.; Cotton, W.; Hyun, Minhee; Kikuta, Satoshi; Nyland, K. E.; Peters, W. M.; Petric, Andreea; Röttgering, Huub J. A.; Shimwell, T.; Yun, Min S. "PEARLS: JWST Counterparts of Microjansky Radio Sources in the Time Domain Field," *The Astrophysical Journal*, 958, 176, 2023.
- Wilson, Christine D.; Bemis, Ashley; Ledger, Blake; Klimi, Osvald "A nearly constant CN/HCN line ratio in nearby galaxies: CN as a new tracer of dense gas," *Monthly Notices of the Royal Astronomical Society*, 521, 717, 2023.
- Winkel, N.; Husemann, B.; Singha, M.; Bennert, V. N.; Combes, F.; Davis, T. A.; Gaspari, M.; Jahnke, K.; McElroy, R.; O'Dea, C. P.; Pérez-Torres, M. A. "The Close AGN Reference Survey (CARS). A parsec-scale multiphase outflow in the super-Eddington NLS1 Mrk 1044," *Astronomy and Astrophysics*, 670, A3, 2023.
- Wójtowicz, Anna; Stawarz, Łukasz; Cheung, C. C.; Werner, Norbert; Rudka, Dominik "Radio Emission of Nearby Early-type Galaxies in the Low and Very Low Radio Luminosity Range," *The Astrophysical Journal*, 944, 195, 2023.
- Wölfer, L.; Facchini, S.; Van Der Marel, N.; Van Dishoeck, E. F.; Benisty, M.; Bohn, A. J.; Francis, L.; Izquierdo, A. F.; Teague, R. D. "Kinematics and brightness temperatures of transition discs. A survey of gas substructures as seen with ALMA," *Astronomy and Astrophysics*, 670, A154, 2023.
- Wong, A.; Hatziminaoglou, E.; Borkar, A.; Popping, G.; Pérez-Fouron, I.; Poidevin, F.; Stoehr, F.; Messias, H. "ALMA High-Level Data Products: submillimetre counterparts of SDSS quasars in the ALMA footprint," *Monthly Notices of the Royal Astronomical Society*, 523, 23, 2023.
- Wood, C. M.; Miller-Jones, J. C. A.; Bahramian, A.; Tingay, S. J.; Russell, T. D.; Tetarenko, A. J.; Altamirano, D.; Belloni, T.; Carotenuto, F.; Ceccobello, C.; Corbel, S.; Espinasse, M.; Fender, R. P.; Körding, E.; Migliari, S.; Russell, D. M.; Sarazin, C. L.; Sivakoff, G. R.; Soria, R.; Tudose, V. "Time-dependent visibility modelling of a relativistic jet in the X-ray binary MAXI J1803-298," *Monthly Notices of the Royal Astronomical Society*, 522, 70, 2023.
- Wright, Melvyn; Hirota, Tomoya; Forbrich, Jan; Plambeck, Richard; Bally, John; Goddi, Ciriaco; Ginsburg, Adam; McQuire, Brett "An Ionized Outflow in Orion-KL Source I?," *The Astrophysical Journal*, 945, 14, 2023.
- Wu, Gang; Henkel, Christian; Xu, Ye; Brunthaler, Andreas; Menten, Karl M.; Qiu, Keping; Li, Jingjing; Zhang, Bo; Esimbek, Jarken "ALMA and VLBA views on the outflow associated with an O-type protostar in G26.50+0.28," *Astronomy and Astrophysics*, 677, A80, 2023.
- Wu, Po-Feng; Bezanson, Rachel; D'Eugenio, Francesco; Gallazzi, Anna R.; Greene, Jenny E.; Maseda, Michael V.; Suess, Katherine A.; Van Der Wel, Arjen "Stars, Gas, and Star Formation of Distant Post-starburst Galaxies," *The Astrophysical Journal*, 955, 75, 2023.
- Wu, Yunjing; Cai, Zheng; Li, Jianan; Finlator, Kristian; Neeleman, Marcel; Prochaska, J. Xavier; Emonts, Bjorn H. C.; Zhang, Shiwu; Wang, Feige; Yang, Jinyi; Wang, Ran; Fan, Xiaohui; Xu, Dandan; Golden-Marx, Emmet; Keating, Laura C.; Hennawi, Joseph F. "Searching for C II Emission from the First Sample of  $z \sim 6$  O I Absorption-associated Galaxies with the Atacama Large Millimeter/submillimeter Array," *The Astrophysical Journal*, 958, 16, 2023.
- Wu, Yunjing; Cai, Zheng; Sun, Fengwu; Bian, Fuyan; Lin, Xiaojing; Li, Zihao; Li, Mingyu; Bauer, Franz E.; Egami, Eiichi; Fan, Xiaohui; González-López, Jorge; Li, Jianan; Wang, Feige; Yang, Jinyi; Zhang, Shiwu; Zou, Siwei "The Identification of a Dusty Multiarm Spiral Galaxy at  $z = 3.06$  with JWST and ALMA," *The Astrophysical Journal*, 942, L1, 2023.
- Wu, Zhongzu; Sotnikova, Yu. V.; Zhang, Bo; Mufakharov, T.; Zhu, Ming; Jiang, Peng; Chen, Yongjun; Shen, Zhiqiang; Sun, Chun; Peng, Hao; Wu, Hong "Radio continuum and OH line emission of high- $z$  OH megamaser galaxies," *Astronomy and Astrophysics*, 669, A148, 2023.
- Xiao, M.-Y.; Elbaz, D.; Gómez-Guijarro, C.; Leroy, L.; Bing, L.-J.; Daddi, E.; Magnelli, B.; Franco, M.; Zhou, L.; Dickinson, M.; Wang, T.; Rujopakarn, W.; Magdis, G. E.; Treister, E.; Inami, H.; Demarco, R.; Sargent, M. T.; Shu, X.; Kartaltepe, J. S.; Alexander, D. M.; Béthermin, M.; Bournaud, F.; Ciesla, L.; Ferguson, H. C.; Finkelstein, S. L.; Giavalisco, M.; Gu, Q.-S.; Iono, D.; Juneau, S.; Lagache, G.; Leiton, R.; Messias, H.; Motohara, K.; Mullaney, J.; Nagar, N.; Pannella, M.; Papovich, C.; Pope, A.; Schreiber, C.; Silverman, J. "The hidden side of cosmic star formation at  $z > 3$ . Bridging optically dark and Lyman-break galaxies with GOODS-ALMA," *Astronomy and Astrophysics*, 672, A18, 2023.
- Xin, Z.; Espaillat, C. C.; Rillinger, A. M.; Ribas, Á.; Macías, E. "Measuring the Dust Masses of Protoplanetary Disks in Lupus with ALMA: Evidence That Disks Can Be Optically Thick at 3 mm," *The Astrophysical Journal*, 942, 4, 2023.
- Xu, Fan; Huang, Yong-Feng; Geng, Jin-Jun "Possible origin of AT2021any: A failed gamma-ray burst from a structured jet," *Astronomy and Astrophysics*, 679, A103, 2023.
- Xu, Feng-Wei; Wang, Ke; Liu, Tie; Goldsmith, Paul F.; Zhang, Qizhou; Juvela, Mika; Liu, Hong-Li; Qin, Sheng-Li; Li, Guang-Xing; Tej, Anandmayee; Garay, Guido; Bronfman, Leonardo; Li, Shanghuo; Wu, Yue-Fang; Gómez, Gilberto C.; Vázquez-Semadeni, Enrique; Tatematsu, Ken'ichi; Ren, Zhiyuan; Zhang, Yong; Toth, L. Viktor; Liu, Xunchuan; Yue, Nannan; Zhang, Siju; Baug, Tapas; Issac, Namitha; Stutz, Amelia M.; Liu, Meizhu; Fuller, Gary A.; Tang, Mengyao; Zhang, Chao; Dewangan, Lokesh; Lee, Chang Won; Zhou, Jianwen; Xie, Jinjin; Jiao, Wenyu; Wang, Chao; Liu, Rong; Luo, Qiuyi; Soam, Archana; Eswaraiah, Chakali "ATOMS: ALMA Three-millimeter Observations of Massive Star-forming regions - XV. Steady accretion from global collapse to core feeding in massive hub-filament system SDC335," *Monthly Notices of the Royal Astronomical Society*, 520, 3259, 2023.
- Xu, Wenrui; Ohashi, Satoshi; Aso, Yusuke; Liu, Hanyu Baobab "Gravitational Instability, Spiral Substructure, and Modest Grain Growth in a Typical Protostellar Disk: Modeling Multiwavelength Dust Continuum Observations of TMC1A," *The Astrophysical Journal*, 954, 190, 2023.
- Xu, Y.; Hao, C. J.; Liu, D. J.; Lin, Z. H.; Bian, S. B.; Hou, L. G.; Li, J. J.; Li, Y. J. "What Does the Milky Way Look Like?," *The Astrophysical Journal*, 947, 54, 2023.
- Yamada, Satoshi; Ueda, Yoshihiro; Herrera-Endoqui, Martín; Toba, Yoshiki; Miyaji, Takamitsu; Ogawa, Shoji; Uematsu, Ryosuke; Tanimoto, Atsushi; Imanishi, Masatoshi; Ricci, Claudio "Hard X-Ray to Radio Multiwavelength SED Analysis of Local U/LIRGs in the GOALS Sample with a Self-consistent AGN Model including a Polar-dust Component," *The Astrophysical Journal Supplement Series*, 265, 37, 2023.
- Yamato, Yoshihide; Aikawa, Yuri; Ohashi, Nagayoshi; Tobin, John J.; Jorgensen, Jes K.; Takakuwa, Shigehisa; Aso, Yusuke; Sai Insa Choi, Jinshi; Flores, Christian; De Gregorio-Monsalvo, Itziar; Hirano, Shingo; Han, Ilseung; Kido, Miyu; Koch, Patrick M.; Kwon, Woojin; Lai, Shih-Ping; Lee, Chang Won; Lee, Jeong-Eun; Li, Zhi-Yun; Lin, Zhe-Yu Daniel; Looney, Leslie W.; Mori, Shoji; Narayanan, Suchitra; Phuong, Nguyen Thi; Saigo, Kazuya; Santamaría-Miranda, Alejandro; Sharma, Rajeeb;

## APPENDIX A: PUBLICATIONS

- Thieme, Travis J.; Tomida, Kengo; Van'T Hoff, Merel L. R.; Yen, Hsi-Wei "Early Planet Formation in Embedded Disks (eDisk). IV. The Ringed and Warped Structure of the Disk around the Class I Protostar L1489 IRS," *The Astrophysical Journal*, 951, 11, 2023.
- Yan, Xi; Lu, Ru-Sen; Jiang, Wu; Krichbaum, Thomas P.; Shen, Zhi-Qiang "Kinematics and Collimation of the Two-sided Jets in NGC 4261: VLBI Study on Subparsec Scales," *The Astrophysical Journal*, 957, 32, 2023.
- Yang, A. Y.; Dzib, S. A.; Urquhart, J. S.; Brunthaler, A.; Medina, S. -N. X.; Menten, K. M.; Wyrowski, F.; Ortiz-León, G. N.; Cotton, W. D.; Gong, Y.; Dokara, R.; Rugel, M. R.; Beuther, H.; Pandian, J. D.; Csengeri, T.; Veena, V. S.; Roy, N.; Nguyen, H.; Winkel, B.; Ott, J.; Carrasco-Gonzalez, C.; Khan, S.; Cheema, A. "A global view on star formation: The GLOSTAR Galactic plane survey. IX. Radio Source Catalog III:  $2^\circ < \ell < 28^\circ$ ,  $36^\circ < \ell < 40^\circ$ ,  $56^\circ < \ell < 60^\circ$  and  $|\text{b}| < 1^\circ$ , VLA B-configuration," *Astronomy and Astrophysics*, 680, A92, 2023.
- Yang, Dongting; Liu, Hong-Li; Tej, Anandmayee; Liu, Tie; Sanhueza, Patricio; Qin, Sheng-Li; Lu, Xing; Wang, Ke; Pan, Sirong; Xu, Feng-Wei; Vázquez-Semadeni, Enrique; Li, Shanghuo; Gómez, Gilberto C.; Palau, Aina; Garay, Guido; Goldsmith, Paul F.; Juvela, Mika; Saha, Anindya; Bronfman, Leonardo; Lee, Chang Won; Tatematsu, Ken'Ichi; Dewangan, Lokesh; Zhou, Jianwen; Zhang, Yong; Stutz, Amelia; Eswaraiyah, Chakali; Toth, L. Viktor; Ristorcelli, Isabelle; Shen, Xianjin; Luo, Anxu; Chibueze, James O. "Direct Observational Evidence of the Multi-scale, Dynamical Mass Accretion Toward a High-mass Star-forming Hub-filament System," *The Astrophysical Journal*, 953, 40, 2023.
- Yang, Haifeng; Fernández-López, Manuel; Li, Zhi-Yun; Stephens, Ian W.; Looney, Leslie W.; Lin, Zhe-Yu Daniel; Harrison, Rachel "Eccentric Dust Ring in the IRS 48 Transition Disk," *The Astrophysical Journal*, 948, L2, 2023.
- Yang, Jinyi; Fan, Xiaohui; Gupta, Ansh; Myers, Adam D.; Palanque-DeLabrouille, Nathalie; Wang, Feige; Yèche, Christophe; Aguilar, Jessica Nicole; Ahlen, Steven; Alexander, David M.; Brooks, David; Dawson, Kyle; De La Macorra, Axel; Dey, Arjun; Dhungana, Govinda; Fanning, Kevin; Font-Ribera, Andreu; Gontcho, Satya; Guy, Julien; Honscheid, Klaus; Juneau, Stephanie; Kisner, Theodore; Kremin, Anthony; Le Guillou, Laurent; Levi, Michael; Magneville, Christophe; Martini, Paul; Meisner, Aaron; Miquel, Ramon; Moustakas, John; Nie, Jundan; Percival, Will; Poppett, Claire; Prada, Francisco; Schlafly, Edward; Tarlé, Gregory; Vargas Magana, Mariana; Weaver, Benjamin Alan; Wechsler, Risa; Zhou, Rongpu; Zhou, Zhimin; Zou, Hu "DESI z = 5 Quasar Survey. I. A First Sample of 400 New Quasars at z 4.7-6.6," *The Astrophysical Journal Supplement Series*, 269, 27, 2023.
- Yang, Qian; Green, Paul J.; Macleod, Chelsea L.; Plotkin, Richard M.; Anderson, Scott F.; Bieri, Allyson; Civano, Francesca; Eracleous, Michael; Graham, Matthew; Ruan, John J.; Runnoe, Jessie; Zhao, Xiarui "Probing the Origin of Changing-look Quasar Transitions with Chandra," *The Astrophysical Journal*, 953, 61, 2023.
- Yang, Xiaolong; Ou, Ziwei "The Core Starbursts of the Galaxy NGC 3628: Radio Very Long Baseline Interferometry and X-Ray Studies," *The Astrophysical Journal*, 952, 27, 2023.
- Yang, Xiaolong; Yang, Jun "Intermediate-Mass Black Holes: The Essential Population to Explore the Unified Model for Accretion and Ejection Processes," *Galaxies*, 11, 53, 2023.
- Yang, Yi; Liu, Haoyu Baobab; Muto, Takayuki; Hashimoto, Jun; Dong, Ruobing; Kanagawa, Kazuhiro; Momose, Munetake; Akiyama, Eiji; Hasegawa, Yasuhiro; Tsukagoshi, Takashi; Konishi, Mihoko; Tamura, Motohide "Multiple Rings and Asymmetric Structures in the Disk of SR 21," *The Astrophysical Journal*, 948, 110, 2023.
- Yao, Yuhan; Ravi, Vikram; Gezari, Suvu; Van Velzen, Sjoert; Lu, Wenbin; Schulze, Steve; Somalwar, Jean J.; Kulkarni, S. R.; Hammerstein, Erica; Nicholl, Matt; Graham, Matthew J.; Perley, Daniel A.; Cenko, S. Bradley; Stein, Robert; Ricarte, Angelo; Chadayammuri, Urmila; Quataert, Eliot; Bellm, Eric C.; Bloom, Joshua S.; Dekany, Richard; Drake, Andrew J.; Groom, Steven L.; Mahabal, Ashish A.; Prince, Thomas A.; Riddle, Reed; Rusholme, Ben; Sharma, Yashvi; Sollerman, Jesper; Yan, Lin "Tidal Disruption Event Demographics with the Zwicky Transient Facility: Volumetric Rates, Luminosity Function, and Implications for the Local Black Hole Mass Function," *The Astrophysical Journal*, 955, L6, 2023.
- Yasuda, Atsushi; Kuno, Nario; Sorai, Kazuo; Muraoka, Kazuyuki; Miyamoto, Yusuke; Kaneko, Hiroyuki; Yajima, Yoshiyuki; Tanaka, Takahiro; Morokuma-Matsui, Kana; Takeuchi, Tsutomu T.; Kobayashi, Masato I. N. "CO multi-line imaging of nearby galaxies (COMING). XII. CO-to-H<sub>2</sub> conversion factor and dust-to-gas ratio," *Publications of the Astronomical Society of Japan*, 75, 743, 2023.
- Yen, Hsi-Wei; Koch, Patrick M.; Lee, Chin-Fei; Hirano, Naomi; Ohashi, Nagayoshi; Sai, Jinshi (Insa Choi); Takakuwa, Shigehisa; Tang, Ya-Wen; Tatematsu, Ken'Ichi; Zhao, Bo "Increasing Mass-to-flux Ratio from the Dense Core to the Protostellar Envelope around the Class 0 Protostar HH 211," *The Astrophysical Journal*, 942, 32, 2023.
- Yoon, Ilsang; Carilli, C. L.; Fujimoto, Seiji; Castellano, Marco; Merlin, Emiliano; Santini, Paola; Yun, Min S.; Murphy, Eric J.; Jung, Intae; Casey, Caitlin M.; Finkelstein, Steven L.; Papovich, Casey; Fontana, Adriano; Treu, Tommaso; Letai, Jonathan "ALMA Observation of a z = 10 Galaxy Candidate Discovered with JWST," *The Astrophysical Journal*, 950, 61, 2023.
- Young, Jason; Pope, Alexandra; Sajina, Anna; Yan, Lin; Gonçalves, Thiago S.; Eleazer, Miriam; Alberts, Stacey; Armus, Lee; Bonato, Matteo; Dale, Daniel A.; Farrah, Duncan; Ferkinhoff, Carl; Hayward, Christopher C.; McKinney, Jed; Murphy, Eric J.; Nesvadba, Nicole; Ogle, Patrick; Sajkov, Leonid; Veilleux, Sylvain "Halfway to the Peak: Spatially Resolved Star Formation and Kinematics in a z = 0.54 Dusty Galaxy with JWST/MIRI," *The Astrophysical Journal*, 958, L5, 2023.
- Yuan, Q.; Zhang, M.; Liu, X.; Jiang, P. F.; Kokhirova, G. I. "Correlation Analysis between OJ 287 Radio Jet Observables," *The Astrophysical Journal*, 949, 20, 2023.
- Yun, Hyeon-Sik; Lee, Jeong-Eun "The Principal Component Analysis Filtering Method for an Unbiased Spectral Survey of Complex Organic Molecules," *The Astrophysical Journal*, 958, 113, 2023.
- Zakardjian, Antoine; Pety, Jérôme; Herrera, Cinthya N.; Hughes, Annie; Oakes, Elias; Kreckel, Kathryn; Faesi, Chris; Glover, Simon C. O.; Groves, Brent; Klessen, Ralf S.; Meidt, Sharon; Barnes, Ashley; Belfiore, Francesco; Bešlić, Ivana; Bigiel, Frank; Blanc, Guillermo A.; Chevance, Mélanie; Dale, Daniel A.; Den Brok, Jakob; Eibensteiner, Cosima; Emsellem, Eric; García-Rodríguez, Axel; Grasha, Kathryn; Koch, Eric W.; Leroy, Adam K.; Liu, Daizhong; Mc Elroy, Rebecca; Neumann, Lukas; Pan, Hsi-An; Querejeta, Miguel; Razza, Alessandro; Rosolowsky, Erik; Saito, Toshiaki; Santoro, Francesco; Schinnerer, Eva; Sun, Jiayi; Usero, Antonio; Watkins, Elizabeth J.; Williams, Thomas "The impact of H II regions on giant molecular cloud properties in nearby galaxies sampled by PHANGS ALMA and MUSE," *Astronomy and Astrophysics*, 678, A171, 2023.
- Zakhochay, Olga V.; Osorio, María Rosa Zapatero; Béjar, Víctor J. S.; Climent, Juan Bautista; Guirado, José Carlos; Gauza, Bartosz; Lodieu, Nicolas; Semenov, Dmitry A.; Perez-Torres, Miguel; Azulay, Rebecca; Rebolo, Rafael; Martín-Pintado, Jesús; Lefèvre, Charlière "New constraints on the presence of debris disks around G 196-3 B and VHS J125601.92-125723.9 b," *Astronomy and Astrophysics*, 674, A66, 2023.
- Zanchettin, M. V.; Feruglio, C.; Massardi, M.; Lapi, A.; Bischetti, M.; Cantalupo, S.; Fiore, F.; Bongiorno, A.; Malizia, A.; Marinucci, A.; Molina, M.; Piconcelli, E.; Tombesi, F.; Travascio, A.; Tozzi, G.; Tripodi, R. "NGC 2992: Interplay between the multiphase disc, wind, and radio bubbles," *Astronomy and Astrophysics*, 679, A88, 2023.
- Zanella, A.; Valentino, F.; Gallazzi, A.; Belli, S.; Magdis, G.; Bolamperti, A. "The large molecular gas fraction of post-starburst galaxies at z > 1," *Monthly Notices of the Royal Astronomical Society*, 524, 923, 2023.
- Zapata, Luis A.; Fernández-López, Manuel; Leurini, Silvia; Guzmán Ccolque, Estrella; Skretas, I. M.; Rodríguez, Luis F.; Palau, Aina; Menten, Karl M.; Wyrowski, Friedrich "One, Two, Three ... An Explosive Outflow in IRAS 12326-6245 Revealed by ALMA," *The Astrophysical Journal*, 956, L35, 2023.



- Zavala, Jorge A.; Buat, Véronique; Casey, Caitlin M.; Finkelstein, Steven L.; Burgarella, Denis; Bagley, Micaela B.; Ciesla, Laure; Daddi, Emanuele; Dickinson, Mark; Ferguson, Henry C.; Franco, Maximilien; Jiménez-Andrade, E. F.; Kartaltepe, Jeyhan S.; Koekemoer, Anton M.; Bail, Aurélien Le; Murphy, E. J.; Papovich, Casey; Tacchella, Sandro; Wilkins, Stephen M.; Aretxaga, Itziar; Behroozi, Peter; Champagne, Jaclyn B.; Fontana, Adriano; Gialalisco, Mauro; Grazian, Andrea; Grogin, Norman A.; Kewley, Lisa J.; Kocevski, Dale D.; Kirkpatrick, Allison; Lotz, Jennifer M.; Pentericci, Laura; Pérez-González, Pablo G.; Pirzkal, Nor; Ravindranath, Swara; Somerville, Rachel S.; Trump, Jonathan R.; Yang, Guang; Aaron Yung, L. Y.; Almaini, Omar; Amorín, Ricardo O.; Annunziatella, Marianna; Haro, Pablo Arabal; Backhaus, Bren E.; Barro, Guillermo; Bell, Eric F.; Bhatawdekar, Rachana; Bisigello, Laura; Buitrago, Fernando; Calabrò, Antonello; Castellano, Marco; Chávez Ortiz, Óscar A.; Chworowsky, Katherine; Cleri, Nikko J.; Cohen, Seth H.; Cole, Justin W.; Cooke, Kevin C.; Cooper, M. C.; Cooray, Asantha R.; Costantin, Luca; Cox, Isabella G.; Croton, Darren; Davé, Romeel; Vega, Alexander De La; Dekel, Avishai; Elbaz, David; Estrada-Carpenter, Vicente; Fernández, Vital; Finkelstein, Keely D.; Freundlich, Jonathan; Fujimoto, Seiji; García-Argumán, Ángela; Gardner, Jonathan P.; Gawiser, Eric; Gómez-Guijarro, Carlos; Guo, Yuchen; Hamilton, Timothy S.; Hathi, Nimish P.; Holwerda, Benne W.; Hirschmann, Michaela; Huertas-Company, Marc; Hutchison, Taylor A.; Iyer, Kartheik G.; Jaskot, Anne E.; Jha, Saurabh W.; Joglee, Sharda; Juneau, Stéphanie; Jung, Intae; Kassin, Susan A.; Kurczynski, Peter; Larson, Rebecca L.; Leung, Gene C. K.; Long, Arianna S.; Lucas, Ray A.; Magnelli, Benjamin; Mantha, Kameswara Bharadwaj; Matharu, Jasleen; Mcgrath, Elizabeth J.; Mcintosh, Daniel H.; Medrano, Aubrey; Merlin, Emiliano; Mobasher, Bahram; Morales, Alexa M.; Newman, Jeffrey A.; Nicholls, David C.; Pandya, Viraj; Rafelski, Marc; Ronayne, Kaila; Rose, Caitlin; Ryan, Russell E.; Santini, Paola; Seillé, Lise-Marie; Shah, Ekta A.; Shen, Lu; Simons, Raymond C.; Snyder, Gregory F.; Stanway, Elizabeth R.; Straughn, Amber N.; Teplitz, Harry I.; Vanderhoof, Brittany N.; Vega-Ferrero, Jesús; Wang, Weichen; Weiner, Benjamin J.; Willmer, Christopher N. A.; Wuyts, Stijn; (The Ceers Team) "Dusty Starbursts Masquerading as Ultra-high Redshift Galaxies in JWST CEERS Observations," *The Astrophysical Journal*, 943, L9, 2023.
- Zawadzki, Brianna; Czekala, Ian; Loomis, Ryan A.; Quinn, Tyler; Grzybowski, Hannah; Frazier, Robert C.; Jennings, Jeff; Nizam, Kadri M.; Jian, Yina "Regularized Maximum Likelihood Image Synthesis and Validation for ALMA Continuum Observations of Protoplanetary Disks," *Publications of the Astronomical Society of the Pacific*, 135, 64503, 2023.
- Zdziarski, Andrzej A.; Veledina, Alexandra; Szanecki, Michał; Green, David A.; Bright, Joe S.; Williams, David R. A. "Evidence for a Black Hole Spin-Orbit Misalignment in the X-Ray Binary Cyg X-1," *The Astrophysical Journal*, 951, L45, 2023.
- Zeng, Lingzhen; Zhang, Qizhou; Alves, Felipe O.; Ching, Tao-Chung; Girart, Josep M.; Liu, Junhao "Submillimeter Observations of Magnetic Fields in Massive Star-forming Region W75N," *The Astrophysical Journal*, 954, 99, 2023.
- Zhang, C.; Zhu, Feng-Yao; Liu, Tie; Ren, Z.-Y.; Liu, H.-L.; Wang, Ke; Wu, J.-W.; Zhang, Y.; Zhou, J.-W.; Tatematsu, K.; Garay, Guido; Tej, Anandmayee; Li, Shanghuo; Xu, W. F.; Lee, Chang Won; Bronfman, Leonardo; Soam, Archana; Li, D. "ATOMS: ALMA three-millimetre observations of massive star-forming regions - XIV. Properties of resolved ultra-compact H II regions," *Monthly Notices of the Royal Astronomical Society*, 520, 3245, 2023.
- Zhang, Lei; Freire, Paulo C. C.; Ridolfi, Alessandro; Pan, Zhichen; Zhao, Jiaqi; Heinke, Craig O.; Chen, Jianxing; Cadelano, Mario; Pallanca, Cristina; Hou, Xian; Fu, Xiaoting; Dai, Shi; Gügercinoğlu, Erbil; Guo, Meng; Hessels, Jason; Hu, Jiale; Li, Guodong; Ni, Mengmeng; Pan, Jingshan; Ransom, Scott M.; Ruan, Qitong; Stairs, Ingrid; Tsai, Chao-Wei; Wang, Pei; Wang, Long; Wang, Na; Wu, Qingdong; Yuan, Jianping; Zhang, Jie; Zhu, Weiwei; Zhang, Yongkun; Li, Di "Discovery and Timing of Millisecond Pulsars in the Globular Cluster M5 with FAST and Arecibo," *The Astrophysical Journal Supplement Series*, 269, 56, 2023.
- Zhang, Lei; Zhang, Zhi-Yu; Nightingale, James W.; Zou, Ze-Cheng; Cao, Xiaoyue; Tsai, Chao-Wei; Yang, Chentao; Shi, Yong; Wang, Junzhi; Xu, Dandan; Lin, Ling-Rui; Zhou, Jing; Li, Ran "Discovery of a radio jet in the Cloverleaf quasar at  $z = 2.56$ ," *Monthly Notices of the Royal Astronomical Society*, 524, 3671, 2023.
- Zhang, Lulu; Ho, Luis C. "Estimating Molecular Gas Content in Galaxies from Polycyclic Aromatic Hydrocarbon Emission," *The Astrophysical Journal*, 943, 1, 2023.
- Zhang, Qian-Qian; Zhou, Ping; Chen, Yang; Zhang, Xiao; Zhong, Wen-Juan; Zhou, Xin; Zhang, Zhi-Yu; Vink, Jacco "Molecular Environment of the Thermal Composite Supernova Remnant G352.7-0.1," *The Astrophysical Journal*, 952, 107, 2023.
- Zhang, Shangjia; Kalscheur, Matt; Long, Feng; Zhang, Ke; Long, Deryl E.; Bergin, Edwin A.; Zhu, Zhaohuan; Trapman, Leon "Substructures in Compact Disks of the Taurus Star-forming Region," *The Astrophysical Journal*, 952, 108, 2023.
- Zhang, Shangjia; Zhu, Zhaohuan; Ueda, Takahiro; Kataoka, Akimasa; Sierra, Anibal; Carrasco-González, Carlos; Macías, Enrique "Porous Dust Particles in Protoplanetary Disks: Application to the HL Tau Disk," *The Astrophysical Journal*, 953, 96, 2023.
- Zhang, Siju; Wang, Ke; Liu, Tie; Zavagno, Annie; Juvela, Mika; Liu, Hongli; Tej, Anandmayee; Stutz, Amelia M.; Li, Shanghuo; Bronfman, Leonardo; Zhang, Qizhou; Goldsmith, Paul F.; Lee, Chang Won; Vázquez-Semadeni, Enrique; Tatematsu, Ken'ichi; Jiao, Wenyu; Xu, Fengwei; Wang, Chao; Zhou, Jian-Wen "ATOMS: ALMA three-millimeter observations of massive star-forming regions - XIII. Ongoing triggered star formation within clump-fed scenario found in the massive (1500 M<sub>⊙</sub>) clump," *Monthly Notices of the Royal Astronomical Society*, 520, 322, 2023.
- Zhang, Stella Yimiao; Duchêne, Gaspard; De Rosa, Robert J.; Ansdell, Megan; Konopacky, Quinn; Esposito, Thomas; Chiang, Eugene; Rice, Malena; Matthews, Brenda; Kalas, Paul; Macintosh, Bruce; Marchis, Franck; Metchev, Stan; Patience, Jenny; Rameau, Julien; Ward-Duong, Kimberly; Wolff, Schuyler; Fitzgerald, Michael P.; Bailey, Vanessa P.; Barman, Travis S.; Bulger, Joanna; Chen, Christine H.; Chilcotte, Jeffrey K.; Cotten, Tara; Doyon, René; Follette, Katherine B.; Gerard, Benjamin L.; Goodsell, Stephen; Graham, James R.; Greenbaum, Alexandra Z.; Hibon, Pascale; Hung, Li-Wei; Ingraham, Patrick; Maire, Jérôme; Marley, Mark S.; Marois, Christian; Millar-Blanchaer, Maxwell A.; Nielsen, Eric L.; Oppenheimer, Rebecca; Palmer, David W.; Perrin, Marshall D.; Poyneer, Lisa A.; Pueyo, Laurent; Rajan, Abhijith; Rantakyro, Fredrik T.; Ruffio, Jean-Baptiste; Savransky, Dmitry; Schneider, Adam C.; Sivaramakrishnan, Anand; Song, Inseok; Soummer, Remi; Thomas, Sandrine; Wang, Jason J.; Wiktorowicz, Sloane J. "Testing the Interaction between a Substellar Companion and a Debris Disk in the HR 2562 System," *The Astronomical Journal*, 165, 219, 2023.
- Zhang, Xian; Yu, Wenfei; Law, Casey; Li, Di; Chatterjee, Shami; Demorest, Paul; Yan, Zhen; Niu, Chenhui; Aggarwal, Kshitij; Anna-Thomas, Reshma; Burke-Spolaor, Sarah; Connor, Liam; Tsai, Chao-Wei; Zhu, Weiwei; Luo, Gan "Temporal and Spectral Properties of the Persistent Radio Source Associated with FRB 20190520B with the VLA," *The Astrophysical Journal*, 959, 89, 2023.
- Zhang, Yan-Kun; Chen, Xi; Song, Shi-Ming; Wang, You-Xin "Luminosity Outburst Energized by the Collision between the Infalling Streamer and Disk in W51 North," *The Astronomical Journal*, 166, 21, 2023.
- Zhang, Yapeng; Ginski, Christian; Huang, Jane; Zurlo, Alice; Beust, Hervé; Bae, Jaehan; Benisty, Myriam; Garufi, Antonio; Hogerheijde, Michiel R.; Van Holstein, Rob G.; Kenworthy, Matthew; Langlois, Maud; Manara, Carlo F.; Pinilla, Paola; Rab, Christian; Ribas, Álvaro; Rosotti, Giovanni P.; Williams, Jonathan "Disk Evolution Study Through Imaging of Nearby Young Stars (DESTINYs): Diverse outcomes of binary-disk interactions," *Astronomy and Astrophysics*, 672, A145, 2023.
- Zhang, Ziwei E.; Yang, Yao-Lun; Zhang, Yichen; Cox, Erin G.; Zeng, Shaoshan; Muriilo, Nadia M.; Ohashi, Satoshi; Sakai, Nami "The Perseus ALMA Chemistry Survey (PEACHES). II. Sulfur-bearing Species and Dust

## APPENDIX A: PUBLICATIONS

- Polarization Revealing Shocked Regions in Protostars in the Perseus Molecular Cloud," *The Astrophysical Journal*, 946, 113, 2023.
- Zhao, Zhi-Chao; Wang, Sai "Bayesian Implications for the Primordial Black Holes from NANOGrav's Pulsar-Timing Data Using the Scalar-Induced Gravitational Waves," *Universe*, 9, 157, 2023.
- Zheng, Xuechen; Röttgering, Huub; Van Der Wel, Arjen; Cappellari, Michele "MaNGA integral-field stellar kinematics of LoTSS radio galaxies: Luminous radio galaxies tend to be slow rotators," *Astronomy and Astrophysics*, 673, A12, 2023.
- Zhong, Wen-Juan; Zhang, Xiao; Chen, Yang; Zhang, Qian-Qian "A study of GeV gamma-ray emission towards supernova remnant G51.26+0.11 and its molecular environment," *Monthly Notices of the Royal Astronomical Society*, 521, 1931, 2023.
- Zhong, Yuxing; Inoue, Akio K.; Sugahara, Yuma; Morokuma-Matsui, Kana; Komugi, Shinya; Kaneko, Hiroyuki; Fudamoto, Yoshinobu "Revisiting the Dragonfly galaxy - I. High-resolution ALMA and VLA observations of the radio hotspots in a hyper-luminous infrared galaxy at  $z = 1.92$ ," *Monthly Notices of the Royal Astronomical Society*, 522, 6123, 2023.
- Zhou, Dong-Dong; Zhou, Jian-Jun; Wu, Gang; Esimbek, Jarken; Xu, Ye "The Environment and Star Formation around the Infrared Bubble N 13," *Research in Astronomy and Astrophysics*, 23, 15011, 2023.
- Zhou, Minhua; Gu, Minfeng; Liao, Mai; Anjum, Muhammad S. "X-ray emission of the radio-loud quasar SDSS J121426.52+140258.9: independent variations between optical/UV and X-ray emission," *Monthly Notices of the Royal Astronomical Society*, 519, 909, 2023.
- Zhou, Xin; Su, Yang; Yang, Ji; Chen, Xuepeng; Sun, Yan; Jiang, Zhibo; Wang, Min; Wang, Hongchi; Zhang, Shaobo; Xu, Ye; Yan, Qingzeng; Yuan, Lixia; Chen, Zhiwei; Ao, Yiping; Ma, Yuehui "A Systematic Study of Associations between Supernova Remnants and Molecular Clouds," *The Astrophysical Journal Supplement Series*, 268, 61, 2023.
- Zhu, Shifu; Brandt, W. N.; Zou, Fan; Luo, Bin; Ni, Qingling; Xue, Yongquan; Yan, Wei "Radio AGN selection and characterization in three Deep-Drilling Fields of the Vera C. Rubin Observatory Legacy Survey of Space and Time," *Monthly Notices of the Royal Astronomical Society*, 522, 3506, 2023.
- Zhu, Yongda; Becker, George D.; Christenson, Holly M.; D'Aloisio, Anson; Bosman, Sarah E. I.; Bakx, Tom; D'Odorico, Valentina; Bischetti, Manuela; Cain, Christopher; Davies, Frederick B.; Davies, Rebecca L.; Eilers, Anna-Christina; Fan, Xiaohui; Gaikwad, Prakash; Haehnelt, Martin G.; Keating, Laura C.; Kulkarni, Girish; Lai, Samuel; Ma, Hai-Xia; Mesinger, Andrei; Qin, Yuxiang; Satyavolu, Sindhu; Takeuchi, Tsutomu T.; Umehata, Hideki; Yang, Jinyi "Probing Ultralate Reionization: Direct Measurements of the Mean Free Path over  $5 < z < 6$ ," *The Astrophysical Journal*, 955, 115, 2023.
- Zobnina, D. I.; Aller, H. D.; Aller, M. F.; Homan, D. C.; Kovalev, Y. Y.; Lister, M. L.; Pashchenko, I. N.; Pushkarev, A. B.; Savolainen, T. "MOJAVE - XXI. Decade-long linear polarization variability in AGN jets at parsec scales," *Monthly Notices of the Royal Astronomical Society*, 523, 3615, 2023.



*Image by Brian R. Kent, NRAO/AUI/NSF*

## APPENDIX B: EVENTS & MILESTONES

### 2021

#### 8 January

NRAO Community Day

#### 11 - 15 January

237th AAS meeting

NRAO Town Hall

ALMA Opportunities & Status Webinar

New Views on Galaxy Formation

Summer Student Presentations

#### 3 February

NRAO Semester 2021B Call for Proposals submission deadline

#### 15 March - 1 April

8th VLA Data Reduction Workshops

#### 21 February

AUI Executive Committee Meeting (Hybrid)

#### 6 March 6

ALMA Ambassadors Cycle 8 Proposal Preparation Workshops (Virtual)

#### 17 March

ALMA Cycle 9 Call for Proposals opens

#### 22 April

ALMA Board Meeting (Virtual)

#### 1 May

Cycle 8 Call for North American ALMA Development Study proposals deadline

#### 12 May

AUI Executive Committee Meeting (Hybrid)

#### 19 - 21 May

16th NRAO Postdoctoral Symposium

#### 26-28 May

NRAO Users Committee/ANASAC Meeting (Virtual)

#### 1 - 3 June

238th American Astronomical Society meeting (Virtual)

NRAO Town Hall

NRAO Virtual Exhibit

#### 18-19 June

AUI Board Meeting (Virtual)

#### 15 - 24 June

6th US-China Radio Astronomy Science Workshop

#### 6 July

NRAO Semester 2021A Call for Proposals opens

#### 14-15 July

Compact Objects and Energetic Phenomena in the Multi-messenger Universe (Virtual)

#### 15 July

Call for Proposals for ALMA Development Projects opens

#### 3 August

NRAO Semester 2022A Call for Proposals deadline

#### 4 - 7 August

The Past, Present, and Future - VLA: Celebrating 40 Years

#### 27 August

AUI Executive Committee Meeting (Virtual)

#### November 17 & 19

Jansky Lecture: Prof. Luis F. Rodriguez

(Virtual)

## 2022

### 2 January

NRAO Semester 2022B Call for Proposals opens

### 20 January

Community Webinar Series: VLA/VLBA Call for Proposals

### 17 February

Webinar: Outcomes from the ALMA Cycle 8 Review

### 16 March

Webinar: ALMA Wideband Sensitivity Upgrade (WSU)

### 24 March

Advanced Synthesis Imaging with CASA

### 27 April

NAASC Data Analyst Recruitment Event

### 18 - 25 May

18th Synthesis Imaging Workshop

### 7 - 9 June

Computational Astrophysics in the ngVLA Era  
New York, NY

### 11-14 June

American Astronomical Society Meeting  
NRAO Science & Development Webinar  
NRAO Town Hall  
Pasadena, CA

### 25 August

Webinar: Cube Analysis and Rendering Tool  
for Astronomy (CARTA)

### 7 - 9 September

The VLA Sky Survey in the Multiwavelength Spotlight  
Socorro, NM

### 21 - 23 September

From Cells to Galaxies: Exploring the Synergies between  
Radio Astronomy & Medical Imaging

### 11 - 20 October

9th VLA Data Reduction Workshop

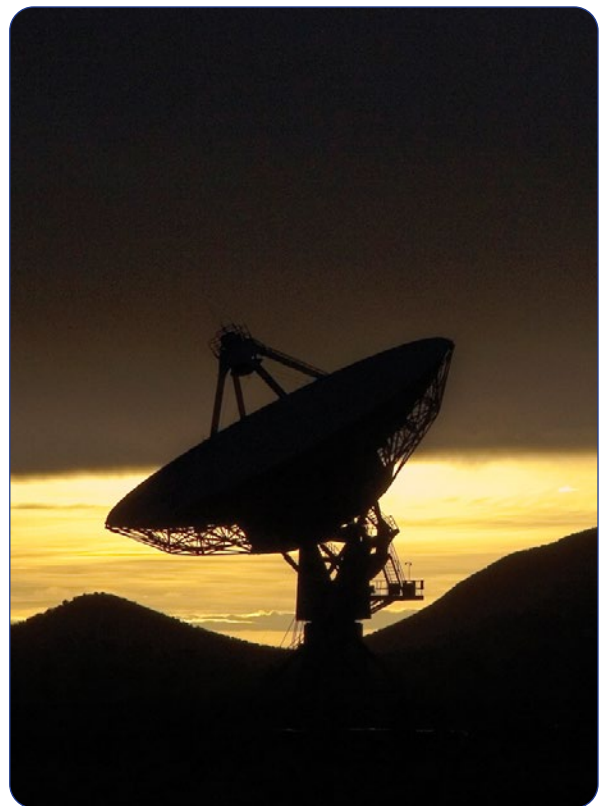

*Very Long Baseline Array (VLBA) antenna, Pie Town, New Mexico.  
Photo by Ian Parker.*

## APPENDIX B: EVENTS & MILESTONES

### 2023

#### 2 January

NRAO Semester 2020B Call for Proposals opens

#### 8 - 11 January

*AAS meeting*

Science Ready Data Products and the VLA Sky Survey

ALMA Status and Plans for Increased Capability

NRAO Town Hall

ngVLA Special Session: Chemical Probes of Astrophysical Systems

#### 14 - 17 February

Jansky Lecture: Prof. Francoise Combes

#### 17 February

28th New Mexico Symposium

Socorro, NM

#### 3 - 4 April

NRAO Community Day at MIT Haystack

Westford, MA

#### 14 - 27 April

ALMA Cycle 10 Proposal Preparation Workshops

#### 1 - 5 May

New Eyes on the Universe: SKA & ngVLA Conference

Vancouver, British Columbia, Canada

#### 15 - 17 May

18th NRAO/GBO Postdoc Symposium

Socorro, New Mexico

#### 4 - 8 June

American Astronomical Society

Albuquerque, New Mexico

#### 13 - 21 June

19th Synthesis Imaging Workshop

#### 10 - 16 June

Gordon Research Conference: Solar Systems

#### 24 - 26 July

New Era of AGN Science with the Vera C. Rubin LSST

Charlottesville, Virginia

#### 1 - 4 August

The Evolution of Gas in and around Galaxies

Stanley, Idaho

#### 6 - 11 August

GBO Single Dish Summer School

Green Bank, WV

#### 11 - 15 September

15th DiFX Users and Developers Meeting

Socorro, New Mexico

#### 25 - 27 September

Morelia ngVLA Science Meeting

Morelia, Mexico

#### 28 - 29 September

NRAO Community Days - IRyA-UNAM Morelia

Morelia, Mexico

#### 28 September

mtex-ngVLA Open Day Event

Leipzig, Germany

#### September - October

Cycle 10 ALMA Data Processing Workshops

#### 6 - 8 November

ALMA Data Reduction Workshops - Data Combination

#### 5 - 9 November

Astronomical Data Analysis & Software Systems (ADASS)

Tucson, Arizona

#### 8 - 17 November

Jansky Lecture: Dr. Paul Vanden Bout

#### 4 - 8 December

ALMA at 10 years: Past, Present, and Future

Puerto Varas, Chile



*Image by Pablo Carillo, ALMA*

## APPENDIX C: ADVISORY COMMITTEES

### NRAO Users and ALMA North American Science Advisory Committees

The NRAO Users Committee (UC) membership includes users and potential users of NRAO facilities from across the scientific community. It advises the Director and the Observatory staff on all aspects of Observatory activities that affect the users of the telescopes. This Committee is appointed by the Director and normally meets in-person annually.

The membership of the NRAO Users Committee from 2021-2023 is given below. In 2014, NRAO integrated the ALMA North American Science Advisory Committee (ANASAC) as a standing subcommittee of the Users Committee. Users Committee members who also serve on the ANASAC are indicated, as are the ANASAC representatives to the international ALMA Science Advisory Committee (ASAC).

Each member's last year in their UC and ANASAC term of service is given.

- **Edo Berger**, Harvard University (2021)
- **Casey Law**, California Institute of Technology (2022)
- **Ilse Cleeves**, Vice-Chair, University of Virginia (2021)
- **Laurent Loinard**, UNAM (2021)
- **Kate Su** (ANASAC), University of Arizona (2021)
- **Alessandra Corsi**, Texas Tech University (2024)
- **Thomas Maccarone**, Texas Tech University (2023)
- **Christopher DePree** (CASA UC), Agnes Scott College (2021)
- **Jin Koda**, Chair (ANASAC), Stony Brook University (2021)
- **Susan Neff**, NASA/GSFC (2022)
- **Meredith Hughes**, Wesleyan University (2023), ANASAC/ASAC
- **James Jackson**, USRA/SOFIA Science Center (2025)
- **Melodie Kao**, ASU (2025)
- **Jin Koda**, Stony Brook University (2021), ANASAC
- **Duncan Lorimer**, West Virginia University (2025)
- **Karen Masters**, Haverford College (2025)
- **Brett McGuire**, Massachusetts Institute of Technology (2025)
- **Stefanie Milam**, NASA/GSFC (2024)
- **Alexandra Pope**, University of Massachusetts Amherst (2023), ANASAC/ASAC
- **Erik Rosolowsky**, University of Alberta (2023), ANASAC/ASAC
- **Kazushi Sakamoto**, Academia Sinica Institute of Astronomy & Astrophysics (2024), ANASAC
- **Melissa Soriano**, NASA Jet Propulsion Laboratory (2025)
- **Kate Su**, University of Arizona (2021), ANASAC
- **Stephen White**, AFRL (2021), ANASAC/ASAC
- **Sean Andrews**, Harvard-Smithsonian Center for Astrophysics (2026), ANASAC
- **Cherry Ng**, University of Toronto (2026)
- **Jennie Paine**, University of Colorado Boulder (2026)
- **Daniel Perley**, Liverpool John Moores University (2026)
- **Elisabeth (Betsy) A. C. Mills**, University of Kansas (2027)
- **Tony Wong**, University of Illinois Urbana-Champaign (2027)



## ALMA North American Science Advisory Committee

The ALMA North American Science Advisory Committee (ANASAC) provides scientific advice to the NRAO Director on the science operation of ALMA and the North American ALMA Science Center, as representatives of the wider North American astronomical community.

Each member's last year in their ANASAC term of service is listed.

- **Sean Andrews**, Chair (ANASAC), Harvard-Smithsonian Center for Astrophysics (2026)
- **Sara Eillson**, University of Victoria (2026)
- **Leslie Looney**, University of Illinois Urbana-Champaign (2027)
- **Meredith MacGregor**, Johns Hopkins University (2027)
- **Brett McGuire**, Massachusetts Institute of Technology (2025)
- **Stefanie Milam**, NASA/GSFC (2024)
- **Kazushi Sakamoto**, Academia Sinica Institute of Astronomy & Astrophysics (2024)
- **Karin Sandstrom**, University of California, San Diego (2027)

## AUI Visiting Committee

The Visiting Committee is appointed by the AUI Board of Trustees to review the management and research programs of the Observatory. The Committee membership follows. Each member's last year in their Visiting Committee term of service is given in parentheses.

- **Lewis Ball**, SKAO (2025)
- **Jeremy Darling**, University of Colorado at Boulder (2025)
- **Lynn Matthews**, Haystack Observatory (2025)
- **Beth Willman**, CEO LSSTC (2025)
- **Rafael Rodriguez Solis**, University of Puerto Rico (2023)
- **Adam Leroy**, Ohio State University (2023)
- **Joan Najita**, National Optical Astronomy Observatory (2023)
- **Greg Taylor**, University of New Mexico (2022)
- **Belinda Wilkes**, Chandra X-ray Center (2021)



## APPENDIX C: ADVISORY COMMITTEES

### NRAO Time Allocation Committee

The persons listed below served on the NRAO Time Allocation Committee (TAC) for Semesters A&B of 2023, 2022, and 2021. The scientific purview of each TAC member is indicated.

#### Semester 2023B

**Poonam Chandra**, GWT,NRAO  
**Craig Heinke**, PCO, University of Alberta  
**Andrew Fox**, ISM, STScl  
**Tracy Clarke**, NGA, NRL  
**Lynn Matthews**, SSP, MIT Haystack Obs.  
**Jaime Pineda**, SFM, MPE  
**Preeti Kharb**, LLA panel, NCRA-TIFR  
**Robert Laing**, HLA, SKAO  
**Katherine Rabidoux**, EGS, UW Platteville  
**James Bartlett**, HIZ, University of Paris/JPL

#### Semester 2022B

**Poonam Chandra**, GWT, NRAO  
**Craig Heinke**, PCO, University of Alberta  
**Conelia Lang**, ISM, Iowa State  
**Andrew Baker**, NGA, Rutgers  
**Lynn Matthews**, SSP, MIT Haystack Obs.  
**Stan Kurtz**, SFM, UNAM  
**Preeti Kharb**, AGN panel, NCRA-TIFR  
**Katherine Rabidoux**, EGS, UW Platteville  
**Paola Andreani**, HIZ, ESO

#### Semester 2021B

**Alexander van der Horst**, GWT, George Washington University  
**Craig Heinke**, PCO, University of Alberta  
**Christina Lacey**, ISM, Hofstra University  
**Andrew Baker**, NGA, Rutgers  
**Lynn Matthews**, SSP, MIT Haystack Obs.  
**Stan Kurtz**, SFM, UNAM  
**Denise Gabuzda**, AGN, University College Cork  
**John Cannon**, EGS, Macalester  
**Paola Andreani**, HIZ, ESO

#### Semester 2023A

**Katherine Rabidoux**, EGS, UW Platteville  
**Preeti Kharb**, LLA panel, NCRA-TIFR  
**Robert Laing**, HLA, SKAO  
**Andrew Baker**, NGA, Rutgers  
**Paola Andreani**, HIZ, ESO  
**Lynn Matthews**, SSP, MIT Haystack Obs.  
**Andrew Fox**, ISM, STScl  
**Stan Kurtz**, SFM, UNAM  
**Poonam Chandra**, GWT,NRAO  
**Craig Heinke**, PCO, University of Alberta

#### Semester 2022A

**Katherine Rabidoux**, EGS, UW Platteville  
**Denise Gabuzda**, AGN, University College Cork  
**Andrew Baker**, NGA, Rutgers  
**Paola Andreani**, HIZ, ESO  
**Lynn Matthews**, SSP, MIT Haystack Obs.  
**Cornelia Lang**, ISM, Iowa State  
**Stan Kurtz**, SFM, UNAM  
**Alexander van der Horst**, GWT, George Washington University  
**Craig Heinke**, PCO, University of Alberta

#### Semester 2021A

**John Cannon**, EGS, Macalester  
**Denise Gabuzda**, AGN, University College Cork  
**Loreto Barcos**, AGN, NRAO  
**David Sanders**, AGN, University of Hawaii'i  
**Lynn Matthews**, SSP, MIT Haystack Obs.  
**Christina Lacey**, ISM, Hofstra University  
**Betsy Mills**, , ISM, University of Kansas  
**Alexander van der Horst**, GWT, George Washington University  
**Craig Heinke**, PCO, University of Alberta

## CASA Users Committee

The NRAO Data Management and Software Department established a Common Astronomy Software Applications (CASA) Users Committee (CUC) to advise it on matters important to CASA users. The scope of the committee's responsibility includes the capabilities, usability, reliability, and performance of CASA with ALMA and VLA data from the perspective of the CASA users community.

The CUC includes five members appointed by the NRAO Assistant Director for Science Support and Research (SSR); two appointed by the East Asian ALMA Regional Center (ARC) manager at the National Astronomical Observatory of Japan; two appointed by the European ARC manager at ESO, and one appointed by the head of the JAO Department of Science operations.

**Adam Leroy** (NA, Chair), Ohio State University

**Ruta Kale** (IN), National Centre for Radio Astrophysics

**Yoshimasa Watanabe** (EA), Shibaura Institute of Technology

**Jihyun Kang** (EA), Korea Astronomy and Space Science Institute

**Olga Bayandina** (EU), INAF, Osservatorio Astrofisico di Arcetri

**Yu-Nung Su** (NA), Academia Sinica Institute of Astronomy and Astrophysics

**Abhijeet Borkar** (EU), Astronomical Institute of the Czech Academy of Sciences

**Imke de Pater** (NA), University of California, Berkeley

**Jane Huang** (NA), Columbia University

**Kristina Nyland** (NA), Naval Research Laboratory

*NA: North America, EU: Europe, EA: East Asia, IN: India*



*Image by Jeff Hellerman, NRAO/AUI/NSF*

## APPENDIX C: ADVISORY COMMITTEES

### ngVLA Science Advisory Council

<b>Andrew Baker</b>	Rutger University	<b>Thomas Maccarone</b>	Texas Tech University
<b>Ted Bergin</b>	University of Michigan	<b>Brenda Matthews</b>	NRCI – Canada
<b>Jennifer Bergner</b>	University of Chicago	<b>Brett McGuire</b>	MIT
<b>Laura Blecha</b>	University of Florida	<b>Betsy Mills</b>	University of Kansas
<b>Geoff Bower</b>	ASIAA	<b>Munetake Momose</b>	Ibaraki University
<b>Sarah Burke-Spolaor</b>	West Virginia University	<b>Cherry Ng</b>	SETI Institute
<b>Carlos Gonzalez</b>	UNAM-IRyA	<b>Rachel Osten</b>	STScI
<b>Alessandra Cori</b>	Texas Tech University	<b>Erik Rosolowsky</b>	University of Alberta
<b>Katherine de Kleer</b>	California Institute of Technology	<b>Nami Sakai</b>	Rikagaku Kenkyūsho
<b>Imke de Pater</b>	University of California, Berkeley	<b>Rachel Somerville</b>	Flatiron Institute
<b>Megan DeCesar</b>	George Mason University	<b>Alexander van der Horst</b>	George Washington Univ.
<b>Mark Dickinson</b>	NOIRLab	<b>Fabian Walter</b>	MPIA
<b>Maria Drout</b>	University of Toronto	<b>David Wilner</b>	Harvard-Smithsonian CfA
<b>Gregg Hallinan</b>	CalTech	<b>Anton Zensus</b>	MPIRA
<b>Bunyo Hatsukade</b>	University of Tokyo		
<b>Takuma Izumi</b>	NAOJ	Ex-Officio Members	
<b>Megan Johnson</b>	United States Naval Observatory	<b>Eric Murphy</b>	NRAO
<b>Joseph Lazio</b>	NASA – Jet Propulsion Lab	<b>Alberto Bolatto</b>	University of Maryland
<b>Adam Leroy</b>	The Ohio State University	<b>Andrea Isella</b>	Rice University

### ngVLA Technical Advisory Council

<b>Lewis Knee</b>	NRCC
<b>Larry D’Addario</b>	NASA – Jet Propulsion Lab
<b>Alvaro Gonzalez</b>	NAOJ
<b>Tetsuo Hasegawa</b>	NAOJ
<b>Yuh-Jing Hwang</b>	ASIAA
<b>Stan Kurtz</b>	UNAM
<b>Michael Rupen</b> (co-chair)	National Research Council – Canada
<b>Melissa Soriano</b> (co-chair)	NASA – Jet Propulsion Lab

Ex-Officio Members

**Rob Selina** NRAO (ngVLA Project Engineer)

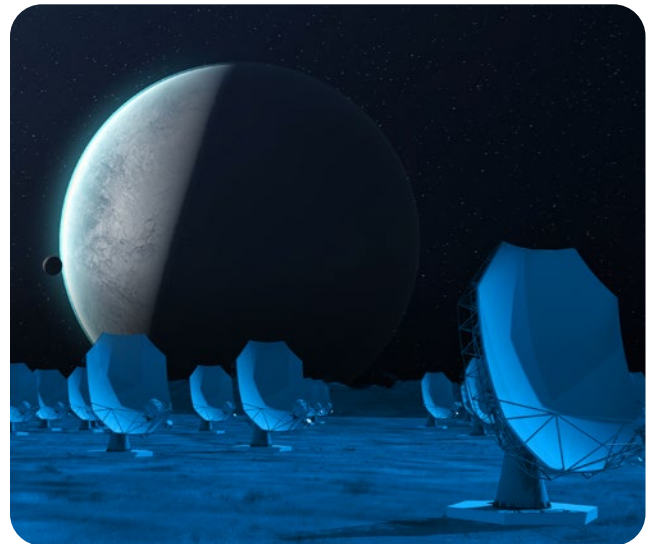

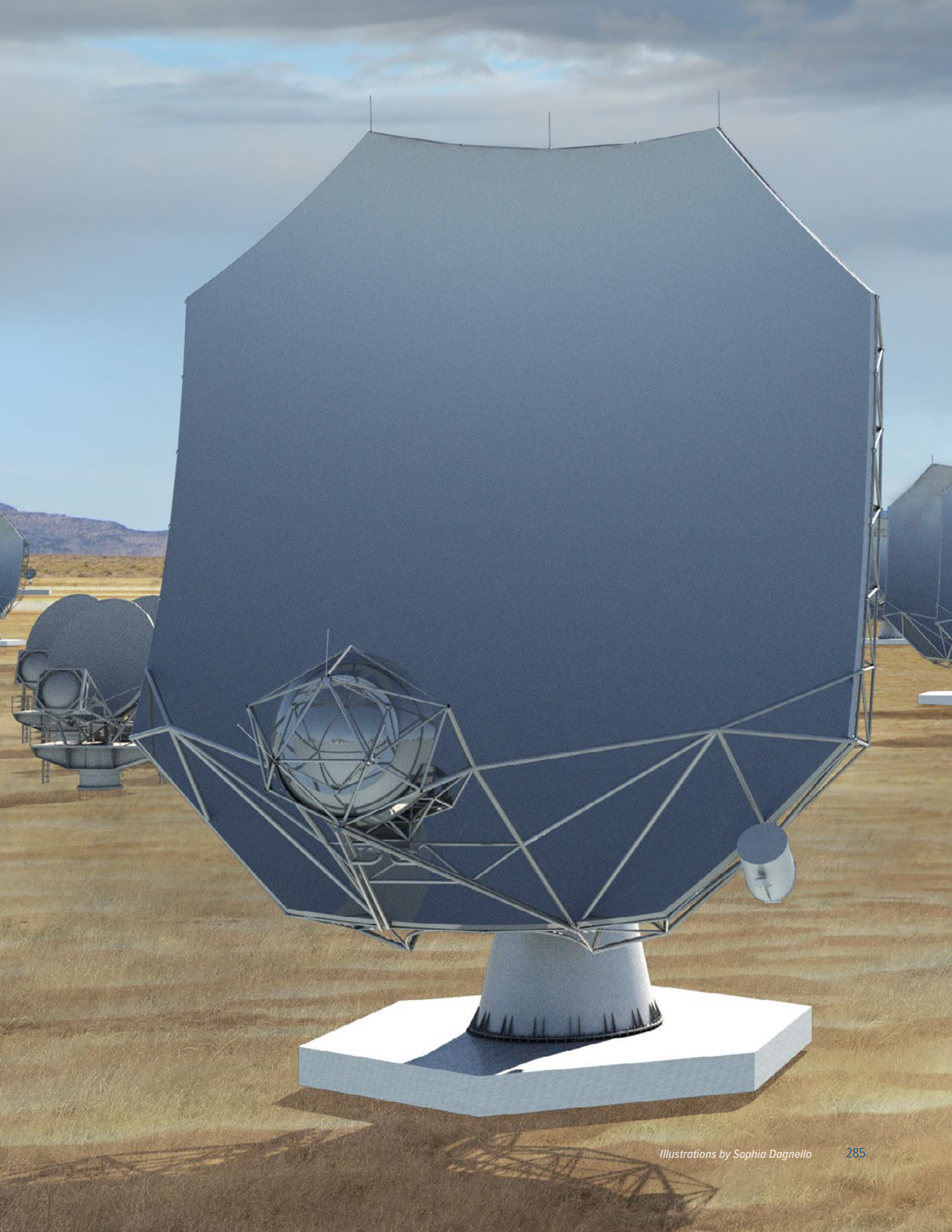

## APPENDIX D: FISCAL YEAR 2021 FINANCIAL SUMMARY

(all figures are \$k USD)

Functional Work Breakdown Structure Element	CSA-V	CSA-A	ICC	CSA-L	Total
Administrative Services	\$11,832	\$12,114	(\$5,574)	\$2,718	\$19,540
Development Programs	\$4,191	\$14,158	\$482	0	\$18,831
Director's Office	\$3,031	\$3,519	\$1,979	\$518	\$8,848
Education & Public Outreach	\$859	\$936	\$0	\$0	\$1,634
Science Operations	\$9,125	\$8,610	\$2,895	\$0	\$20,630
Telescope Operations	\$11,386	\$23,607	\$102	\$6,766	\$41,862
<b>Grand Total</b>	<b>\$40,795</b>	<b>\$61,035</b>	<b>(\$116)</b>	<b>\$10,003</b>	<b>\$111,346</b>

Fiscal Year 2021 = 1 October 2020 – 30 September 2021; CSA = Cooperative Support Agreement, V = VLAN/LBA, A = ALMA, L = LBO, ICC = Internal Common Costs

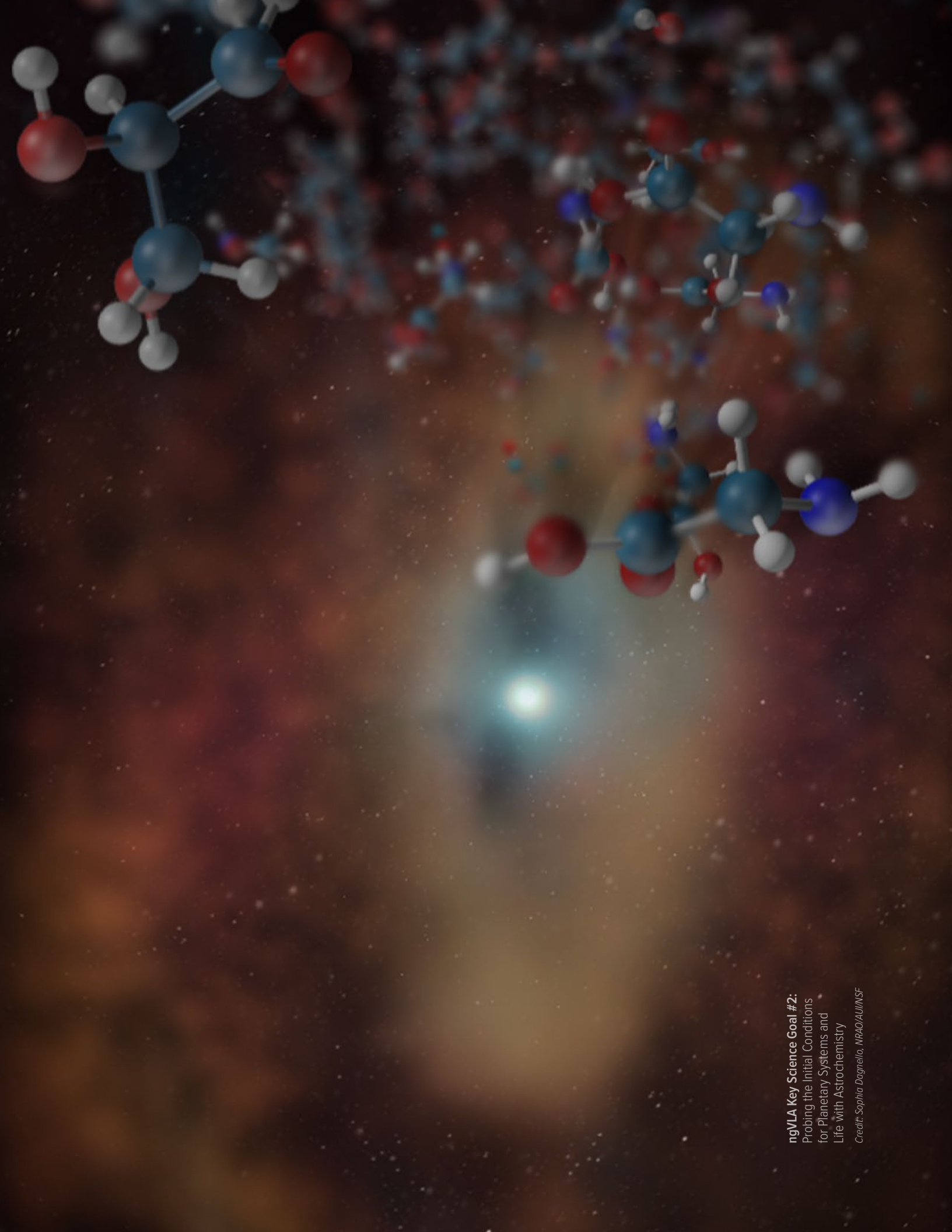

**ngVLA Key Science Goal #2:**  
Probing the Initial Conditions  
for Planetary Systems and  
Life with Astrochemistry

*Credit: Sophia Dagnello, NRAO/AUI/NSF*

## APPENDIX D: FISCAL YEAR 2022 FINANCIAL SUMMARY

(all figures are \$k USD)

Functional Work Breakdown Structure Element	CSA-V	CSA-A	ICC	CSA-L	Total
Administrative Services	\$11,137	\$10,817	(\$2,095)	\$2,736	\$22,595
Development Programs	\$5,085	\$7,423	\$500	\$0	\$13,008
Director's Office	\$3,064	\$3,859	\$2,143	\$518	\$9,584
Education & Public Outreach	\$843	\$839	\$0	\$0	\$1,682
Science Operations	\$8,782	\$8,752	\$2,980	\$0	\$20,514
Telescope Operations	\$11,072	\$24,110	\$113	\$5,819	\$41,114
<b>Grand Total</b>	<b>\$39,983</b>	<b>\$55,800</b>	<b>\$3,641</b>	<b>\$9,073</b>	<b>\$108,497</b>

Fiscal Year 2022 = 1 October 2021 – 30 September 2022; CSA = Cooperative Support Agreement; V = VLA/VLBA; A = ALMA; L = LBO; ICC = Internal Common Costs





ngVLA Key Science Goal #5:  
Understanding Black Holes  
Credit: Sophia Dagnello, NRAO/AUI/NSF



## APPENDIX D: FISCAL YEAR 2023 FINANCIAL SUMMARY

(all figures are \$k USD)

Functional Work Breakdown Structure Element	CSA-V	CSA-A	ICC	Total
Administrative Services	\$16,335	\$10,282	(\$6,574)	\$20,043
Development Programs	\$4,511	\$22,093	\$528	\$27,132
Director's Office	\$3,688	\$3,815	\$2,654	\$10,156
Education & Public Outreach	\$979	\$936	\$0	\$1,915
Science Operations	\$10,310	\$10,020	\$3,362	\$23,692
Telescope Operations	\$23,185	\$32,607	\$212	\$56,004
<b>Grand Total</b>	<b>\$59,007</b>	<b>\$79,753</b>	<b>\$182</b>	<b>\$138,942</b>

Fiscal Year 2023 = 1 October 2022 – 30 September 2023; CSA = Cooperative Support Agreement, V = VLAV/LBA, A = ALMA, ICC = Internal Common Costs



ngVLA Key Science Goal #4:  
Gravity Studies

Credits: Sophia Dagnello, NRAO/AUI/NSF

## APPENDIX E: ACRONYMS

### Acronym Definition

AAAS	American Association for the Advancement of Science
AAB	Antenna Assembly Building
AAS	American Astronomical Society
AATF	African American Teaching Fellows
ACA	Atacama Compact Array
ACEAP	Education Ambassadors Program
ACS	ALMA Common Software
ACU	Antenna Control Unit
AGN	Active Galactic Nuclei
ALMA	Atacama Large Millimeter/submillimeter Array
ANASAC	ALMA North American Science Advisory Committee
AoD	Astronomer on Duty
AOS	Array Operations Site
AR	Augmented Reality
ARC	ALMA Regional Center
arcsec	arcsecond
ASIAA	Academia Sinica Institute for Astronomy and Astrophysics
ASIC	Application Specific integrated Circuit
ASKAP	Australian Square Kilometre Array Pathfinder
ASPECS	ALMA Spectroscopic Survey in the Hubble Ultra Deep Field
AST	NSF Division of Astronomical Sciences
AU	Astronomical Unit
AUI	Associated Universities, Incorporated
B&C	beamforming and channelizing
BI	Broader Impacts
BLC	Baseline Correlator
CARF	Committee on Radio Astronomy Frequencies
CARMA	Combined Array for Research in Millimeter Astronomy
CARTA	Cube Analysis and Rendering Tool for Astronomy
CASA	Common Astronomy Software Applications
CBE	Correlator Back End
CDL	Central Development Laboratory
CDR	Critical Design Review
CHILES	Cosmos HI Large Extragalactic Survey
CHIME	Canadian Hydrogen Intensity Mapping Experiment
CHTC	Center for High Throughput Computing
CIRADA	Canadian Initiative for Radio Astronomy Data Analysis
CIS	Computing Information Systems
CoDR	Conceptual Design Review
CO-I	Co-Investigator
CORE	Council of Representative for Engagement
CORF	Committee on Radio Frequencies
COSPAR	Committee on Space Research
CPM	Conference Preparatory Meeting
CSA	Cooperative Support Agreement
CSIRO	Commonwealth Scientific and Industrial Research Organization
CSP	Central Signal Processor

CTP	Cosmic Twilight Polarimeter
CUP	Correlator upgrade Project
DAPPER	Dark Ages Polarimeter Pathfinder
DDT	Director's Discretionary Time
DMS	Data Management & Software
DOMT	Digital Orthomode Transducers
DSACore	Dynamic Scheduling Algorithm
DSN	Deep Space Network
DSOC	Domenici Science Operations Center
DSP	Digital Signal Processing
EBG	Electromagnetic Band Gap
EGS	Extragalactic Structure
EHT	Event Horizon Telescope
EM	Electromagnetic
EMSS	ElectroMagnetic Software and Systems
Eol	Expression of Interest
EPO	Education and Public Outreach
ERIC	European Research Infrastructure Consortium
ESO	European Organisation for Astronomical Research in the Southern Hemisphere
ETP	Energetic Transients and Pulsars
EVLA	Expanded Very Large Array
f2f	face-to-face
FBOT	Fast Blue Optical Transient
FCC	Federal Communications Commission
FE	Front End
FEHV	Front End Handling Vehicles
FIRST	Faint Images of the Radio Sky at Twenty Centimeters
FPGA	Field Programmable Gate Array
FRB	Fast Radio Bursts
FRM	Focus Rotation Mount
FSA	Frequency Site Architecture
FTE	Full Time Equivalent
GBO	Green Bank Observatory
GBT	Green Bank Telescope
GDMS	General Dynamics Mission Systems
GHz	Gigahertz
GMVA	Global 3mm VLBI Array
GO	General Observing
GOST	General Observing Setup Tool
GRB	Gamma Ray Burst
GW	Gravitational Wave
GWT	Gravitational Waves & Energetic Transients
HBCU	Historically Black Colleges and Universities
HEMT	High Electron Mobility Transistor
HERA	Hydrogen Epoch of Reionization Array
HiLS	Hardware in the Loop Simulations
HIZ	High Redshift & Source Surveys

## APPENDIX E: ACRONYMS

HPC	High Performance Computing
HR	Human Resources
HSA	High Sensitivity Array
HSI	Hispanic Serving Institutions
HST	Hubble Space Telescope
IAU	International Astronomical Union
ICRF	International Celestial Reference Frame
IEEE	Institute of Electrical and Electronics Engineers
IF	Intermediate Frequency
IRD	Integrated Receiver Development
ISM	Interstellar Medium
IT	Information Technology
ITU-R	International Telecommunication Union – Radiocommunication
IUCAF	Inter-Union Committee on the Allocation of Frequencies
JAO	Joint ALMA Observatory
JPL	Jet Propulsion Laboratory
kpc	kiloparsec
KSG	Key Science Goals
LA	Los Alamos
LBA	Long Baseline Array
LNA	Low Noise Amplifier
LNF	Low Noise Factory
LO	Local Oscillator
LRU	Line Replaceable Unit
LWA	Long Wavelength Array
MA	Main Array
M&C	Monitor and Control
MHz	Megahertz
MIT	Massachusetts Institute of Technology
MMIC	Monolithic Millimeter-wave Integrated Circuit
MoU	Memorandum of Understanding
MPIfR	Max Planck Institut für Radioastronomie
MPIfA	Max Planck Institut für Astronomie
MREFC	Major Research Equipment and Facility Construction
MSI	Minority Serving Institution
MSV3	Measurement Set Version 3
Myr	Megayear
NA	North American
NAASC	North American ALMA Science Center
NAOJ	National Astronomical Observatory of Japan
NASA	National Aeronautics and Space Administration
NEON	National Ecological Observatory Network
NESS	Network for Exploration and Space Sciences
NGA	Normal Galaxies, Groups, and Clusters
NGC	New General Catalog
ngVLA	next generation Very Large Array
NINS	National Institutes of Natural Sciences (Japan)
NM	New Mexico



*Photo by Jeff Hellerman, NRAO/AUI/NSF*

## APPENDIX E: ACRONYMS

NMT	New Mexico Institute of Mining and Technology
NRAO	National Radio Astronomy Observatory
NRCC	National Research Council-Canada
NRC-HIA	National Research Council of Canada-Herzberg Astronomy and Astrophysics
NRL	Naval Research Laboratory
NRQZ	National Radio Quiet Zone
NSF	National Science Foundation
NSBP	National Society of Black Physicists
NVSS	NRAO VLA Sky Survey
OCA	Office of Chilean Affairs
OMT	OrthoMode Transducer
OPT	Observation Preparation Tool
OSF	Operations Support Facility
OT	Observing Tool
pc	parsec
PCO	Pulsars and Compact Objects
PDR	Preliminary Design Review
PEP	Performance Evaluation Process
PHT	Proposal Handling Tool
PI	Principal Investigator
PIO	Public Information Officer
PM	Program Management
PST	Proposal Submission Tool
PT	Pie Town
QA	Quality Assurance
R&D	Research & Development
RADIAL	Radio Astronomy Data Imaging and Analysis
RAP-NM	Radio Astronomy and Physics in New Mexico
REU	Research Experiences for Undergraduates
RF	Radio Frequency
RFI	Radio-Frequency Interference
RFP	Request for Proposal
RHEL	Red Hat Enterprise Linux
RMS	Radio-Millimeter-Submillimeter
RSRO	Resident Shared Risk Observing
SBA	Short Baseline Array
SAC	Science Advisory Council
SADC	Serial Analog to Digital Converter
SB	Scheduling Blocks
SciCom	Science Communications Office
SC	Saint Croix
SCG	Science Computing Group
SCO	Santiago Central Office
SCR	Silicon Controlled Rectifiers
SCREAM	Scalable Reconfigurable Modular
SDM	Science Data Model
SFM	Star Formation
SIS	Superconductor–Insulator–Superconductor



SKA ..... Square Kilometre Array  
 SMBH ..... Supermassive Black Hole  
 SOC ..... Scientific Organizing Committee  
 SOL ..... Standard of Learning  
 SOS ..... Student Observing Support  
 SRAO ..... Science Ready Archive and Operations  
 SRDP ..... Science Ready Data Products  
 SRO ..... Shared Risk Observing  
 SRP ..... Science Review Panel  
 SSP ..... Solar System, Stars & Planetary Systems  
 SSR ..... Science Support and Research  
 STEAM ..... Science, Technology, Engineering, Art, and Mathematics  
 STScI ..... Space Telescope Science Institute  
 SUS ..... Scientific User Support  
 SWG ..... Science Working Group  
 TAC ..... Time Allocation Committee  
 TKIP ..... Traveling-wave Kinetic Inductance Parametric  
 TTA ..... Telescope Time Allocation  
 U/LIRG ..... Ultraluminous/Luminous Infrared Galaxies  
 UAV ..... Unmanned Aerial Vehicle  
 UC ..... Users Committee  
 UNM ..... University of New Mexico  
 URSI ..... International Union of Radio Science; Union Radio Scientifique Internationale  
 UVA ..... University of Virginia  
 UVML ..... University of Virginia Microfabrication Laboratory  
 VA ..... Virginia  
 VANDAM ..... VLA/ALMA Nascent Disk and Multiplicity  
 VFD ..... Variable Frequency Drive  
 VLA ..... Very Large Array  
 VLASS ..... Very Large Array Sky Survey  
 VLBA ..... Very Long Baseline Array  
 VLBI ..... Very Long Baseline Interferometry  
 VLT ..... Very Large Telescope  
 VME ..... VLBA Versa Model Eurocard  
 VNDA ..... VLBA New Digital Architecture  
 WFO ..... Work for Others  
 WIDAR ..... Wideband Interferometric Digital Architecture  
 WISE ..... Widefield Infrared Survey Explorer  
 WRC ..... World Radio Conference  
 WVR ..... Water Vapor Radiometer  
 YUPPI ..... Y Ultimate Pulsar Processing Instrument  
 ZTF ..... Zwicky Transient Facility

science.nrao.edu  
public.nrao.edu  
ngvla.nrao.edu  
almascience.nrao.edu

**NRAO Headquarters and North American ALMA Science Center**

National Radio Astronomy Observatory  
520 Edgemont Road  
Charlottesville, Virginia U.S.A 22903-2475  
+1-434-296-0211

**NRAO - Central Development Laboratory**

National Radio Astronomy Observatory  
1180 Boxwood Estate Road  
Charlottesville, Virginia U.S.A 22903-4608  
+1-434-296-0358

**NRAO - Pete V. Domenici Science Operations Center**

National Radio Astronomy Observatory  
P. O. Box 0  
Socorro, New Mexico U.S.A 87801-0387  
+1-575-835-7000

**NRAO/AUI - Chile**

NRAO/AUI  
Av. Alonso de Córdova 2860  
Office 702  
Vitacura, Santiago Chile, 7630440  
+56-2-2210-9600



The National Radio Astronomy Observatory is a facility of the  
United States National Science Foundation operated by Associated Universities, Inc.