

A.J. Beasley¹, D. Dunbar¹, D. Chalmers², R. Selina³, B. McCreight⁴

¹National Radio Astronomy Observatory, Charlottesville, VA

²National Research Council of Canada - Herzberg Astronomy and Astrophysics, Penticton/Victoria, BC, CANADA,

³National Radio Astronomy Observatory, Socorro, NM,

⁴General Dynamics Missions Systems, Plano, TX

ngVLA Array Concept

The ngVLA will be a synthesis radio telescope constituted of approximately 244 reflector antennas each of 18 meters diameter, operating in a phased or interferometric mode. It will operate over a frequency range extending from 1.2 GHz to 116 GHz.

The signal processing center of the array will be located at the Very Large Array site, on the plains of San Agustin, New Mexico. The array will include stations in other locations throughout New Mexico, west Texas, eastern Arizona, and northern Mexico and several locations throughout the US, Hawaii and Caribbean.

Operations will be conducted from both the VLA Control Building and the Array Operations Center in Socorro, NM.

General Dynamics Mission System Antenna Concept

The low-technical-risk antenna analog for the ngVLA antenna study was developed by General Dynamics Mission Systems. The GDMS concept is scaled from the successful 13.5m MeerKAT antenna design. The offset Gregorian optics are provided by an aluminum segmented main reflector and a single piece subreflector. These are supported by a steel radial truss structure and feed arm. A central cavity in the backup structure eliminates interference with the pedestal while moving the azimuth axis closer to the reflector surface. This reduces the need for counterweight to allow for faster slew and settle times.

GDMS investigated several mount configurations and decided on a pedestal with turnhead concept due to favorable construction and operations cost. The servo system relies on a gearbox drive for azimuth rotation and a jack screw for elevation.

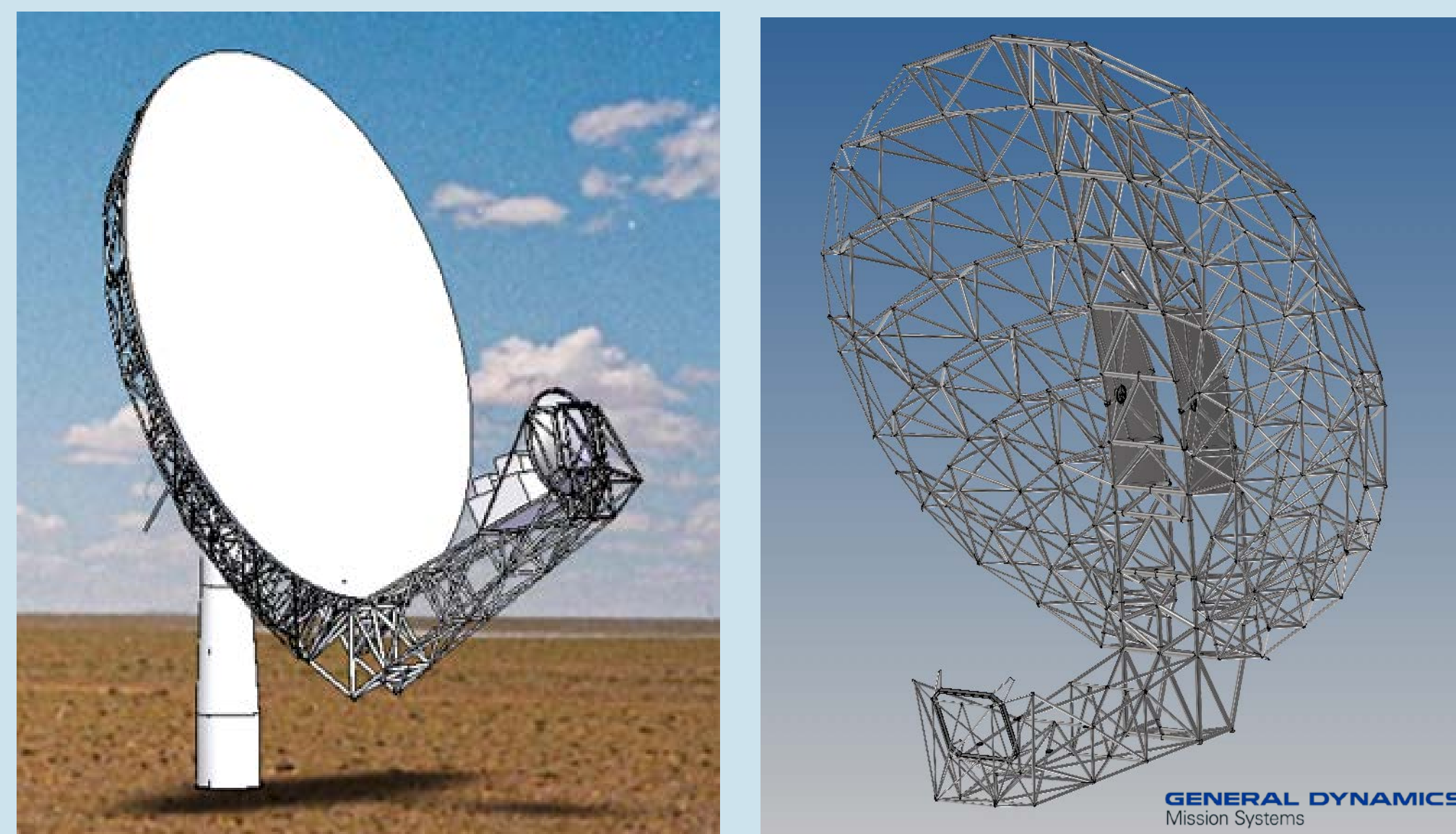

Figure 1: Front view and proposed back up structure of the General Dynamics Mission Systems 18m Antenna

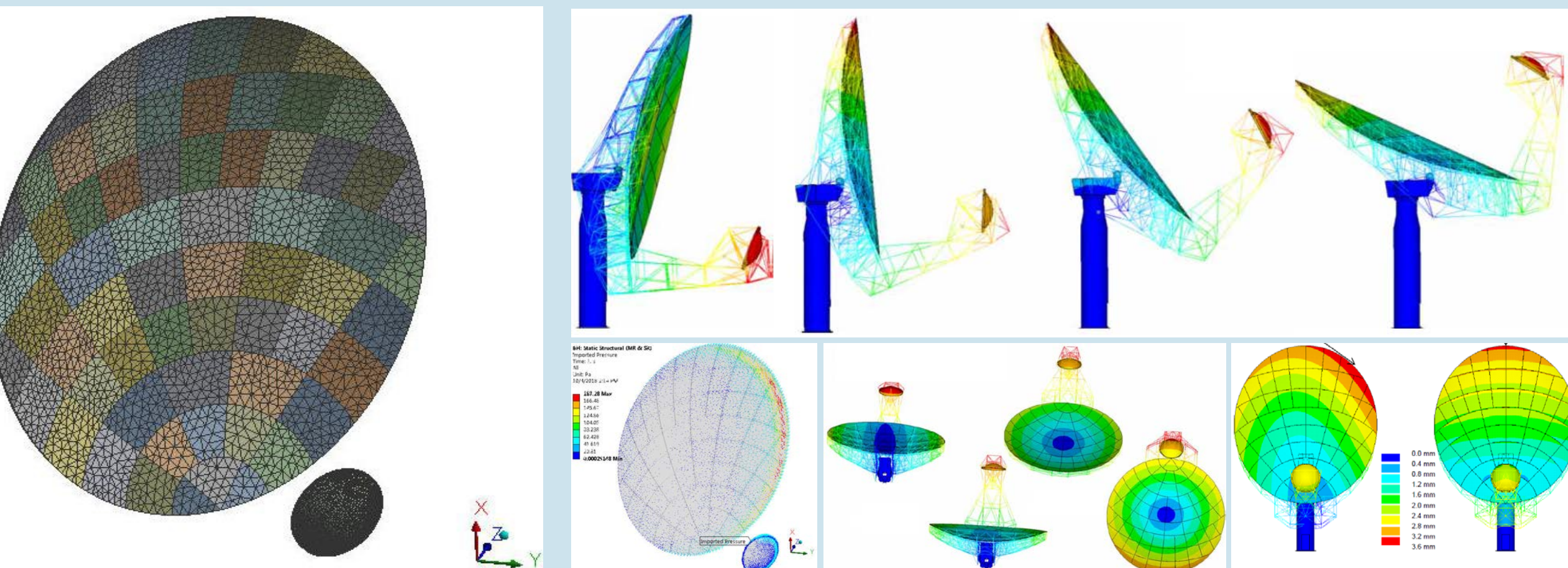

Figure 2: (left) Proposed 84 segmented panels with FEA/CFD mesh applied. (right) FEA analysis of gravity, thermal, and differential wind pressure.

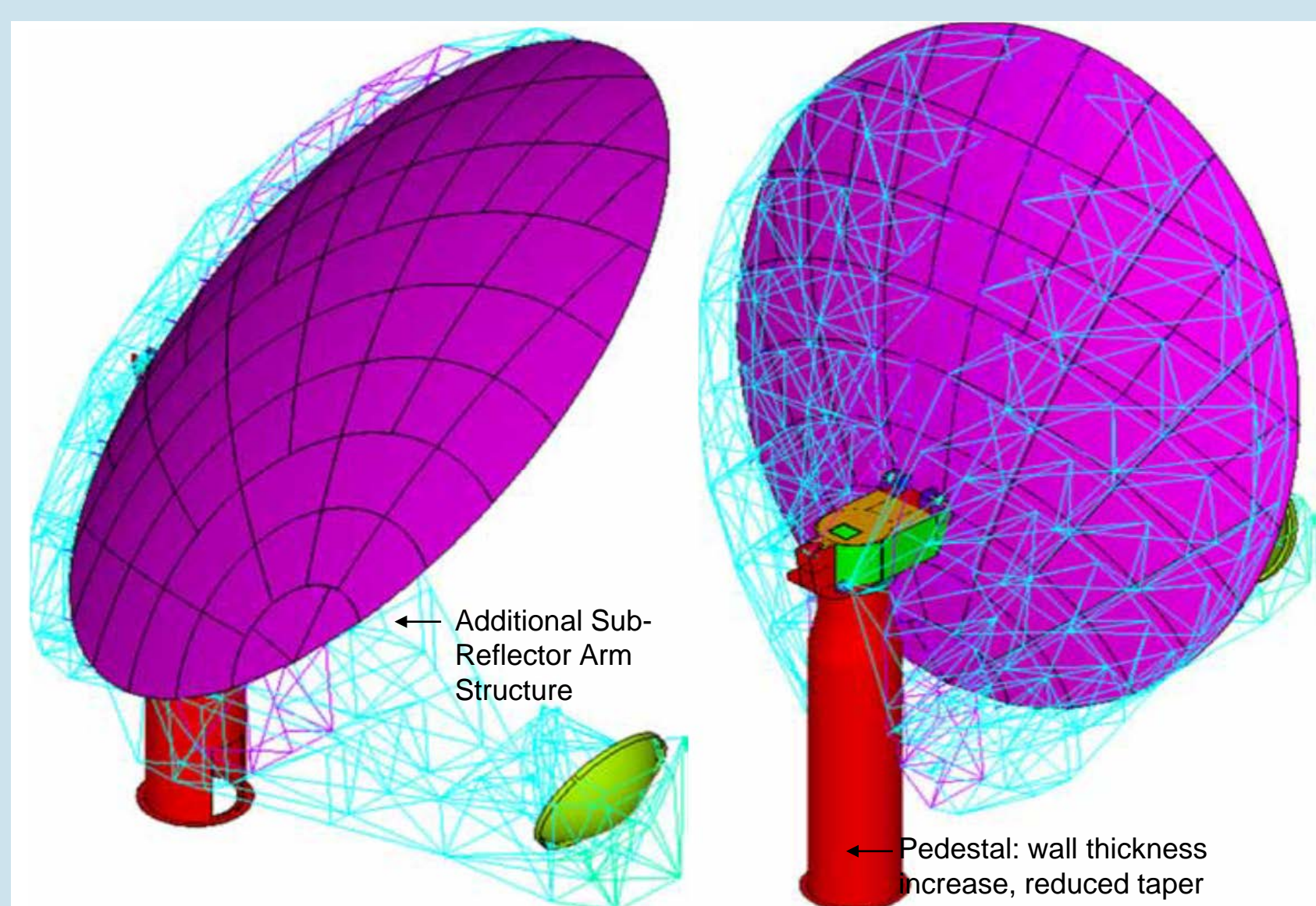

Figure 3: Antenna structure changes as a result of the FEA analysis. Additional structure was added to the sub-reflector feed arm and the pedestal mount was modified (wall thickness increase and shape change).

Abstract

The Karl Jansky Very Large Array (VLA) has proven to be one of the most productive radio telescopes at centimeter wavelengths. The NRAO is now investigating the future of centimeter wavelength astronomy in the northern hemisphere, spanning the gap between thermal and non-thermal emission mechanisms, and bridging the capabilities of ALMA and SKA. The Next Generation Very Large Array is a design and development project of the National Science Foundation operated under cooperative agreement by Associated Universities, Inc.

The scientific mission, specifications and technical concept of a next-generation VLA (ngVLA) are presently being developed. Preliminary goals for the ngVLA are to enormously increase both the system sensitivity and angular resolution of the VLA and ALMA tenfold for frequencies spanning 1.2 GHz to 116 GHz. The design of the antenna will be a major construction and operations cost driver for the facility.

The antennas must have acceptable aperture efficiency and pointing for operation up to 116 GHz yielding five to ten times the total collecting area of the VLA. Unblocked apertures are preferred, with wide subreflector subtended angles for compact feed and receiver packages. Improved reliability and ease of access to the receiver and servo electronics packages, will be required to meet the operations requirements.

This poster, which includes the antenna concepts and specifications presents the high-level design for the antenna developed by the NRAO, NRCC, GDMS, and our partners. The poster highlights further studies and design work that will contribute to the design.

Key Performance Parameters

Table 1: ngVLA Antenna Parameters	
Parameter	Summary of Requirement
Antenna Diameter	18m Main Array, 18m Total Power
Frequency Range	1.2-116 GHz
Number of Antennas	244
Antenna Optics	Offset Gregorian, Feed Low, Shaped
Front Ends	Single Pixel Feeds, Dual Linear Polarization
Surface Accuracy	Precision Operating Conditions 160 μ m rms ($N/16$ @ 116 GHz), primary and subreflector combined. Normal Operating Conditions 300 μ m rms, primary and subreflector combined.
Pointing Accuracy	Precision Operating Conditions: (4 deg angle, 15 min time) Absolute pointing: 18 arc sec rms Referenced pointing: 3 arc sec rms Normal Operating Conditions: (4 deg angle, 15 min time) Absolute pointing: 35 arc sec rms Referenced pointing: 5 arc sec rms
Tracking Range	Azimuth: ± 270 deg Elevation: 12 deg to 88 deg
Movement Rate	Slew: Azimuth 90 deg/min, Elevation 45 deg/min. Tracking: Azimuth 7.5 deg/min, Elevation 3.5 deg/min.

Analysis & Expected Performance

GDMS strived for a design that targeted a per antenna cost goal and the best performance that could be achieved at that cost. The design, as delivered, did not meet all of the specifications including the pointing and surface accuracy, but GDMS identified further steps that could be taken to meet the specifications and their associated cost. This approach, given the large quantity of antennas, allows NRAO to weigh the cost benefit of incremental changes to the specification.

NRC developed an antenna design that has shown the ability to meet all of the key performance parameters and thus was the candidate used for the submitted reference design. Next steps for the 18m design is to better understand the impact of segmenting a single piece reflector (SRC) into a multi piece reflector (MRC). NRC conducted a study with a large transport operation and the results indicated that a single piece reflector will be able to be transported to 170 of the 244 proposed sites, leaving the remaining 74 to be fitted with a multi piece reflector.

Future Work

While substantial progress was made for the reference design; the NRAO is continuing our effort to develop the best performance antenna within an assumed cost envelope. NRAO has released three awards to three additional antenna designers to develop an antenna costed concept design for the purpose of having more options to choose from for the next phase, the final design and prototype. In addition, NRAO is working with NRC to better understand the risks and retire unknowns about the composite reflector design.

National Research Council of Canada Antenna Concept

The NRC ngVLA antenna design is based on the Single-piece Rim-supported Composite (SRC) reflector technology developed at NRC over the past decade. The SRC concept was first successfully implemented on the DVA1 antenna, designed to work up to 10GHz. Following further development, the SRC technology was also implemented into the DVA2 reflector, designed to operate up to 50GHz. Both of these antennas used a tubular steel frame Back-Up Structure (BUS).

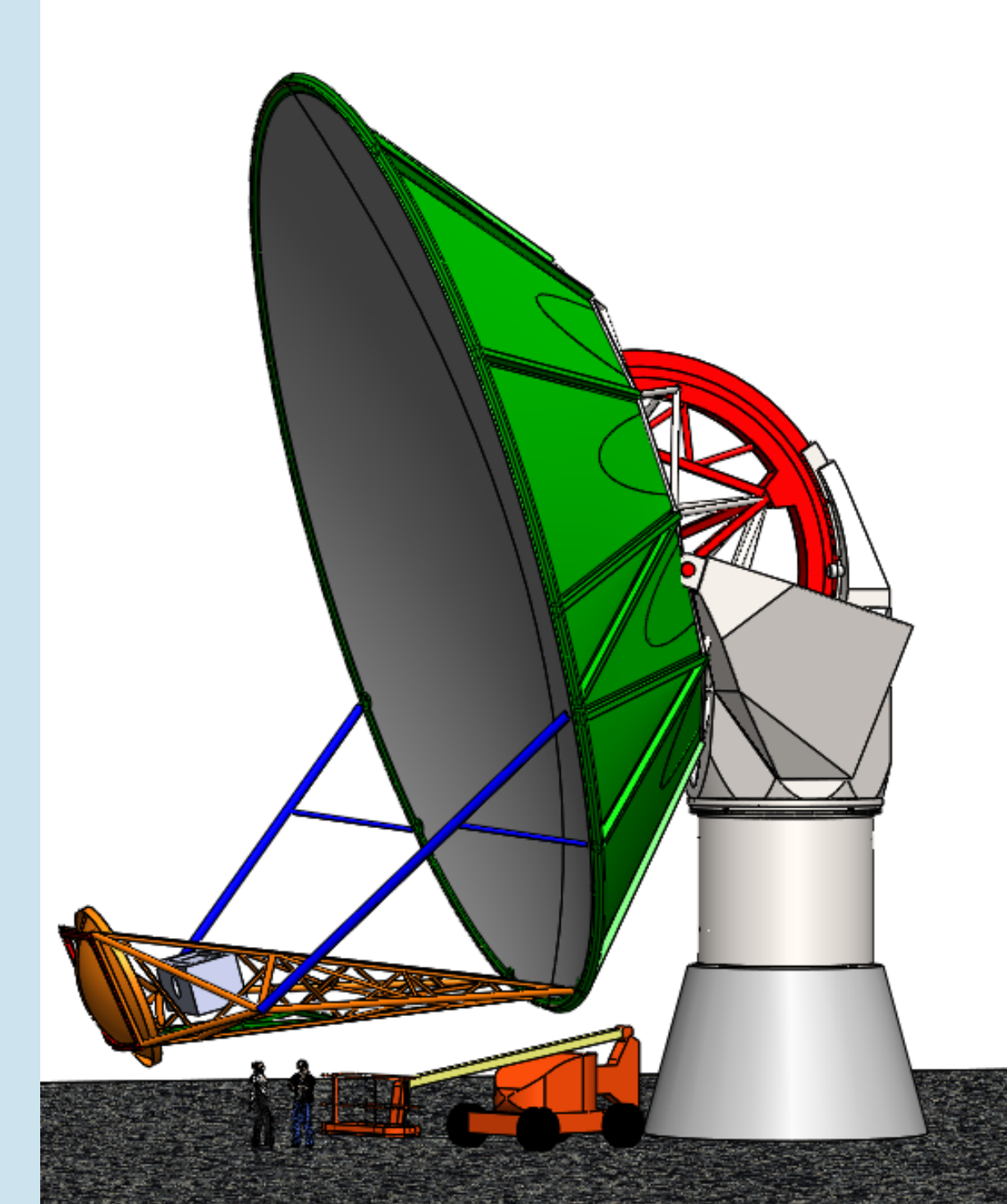

Figure 4: NRC 18m Antenna Concept.

Upon conclusion of the study, NRC provided a design that was marginally deficient in meeting the key performance parameters, specifically the surface accuracy and pointing error, noting that conservative design assumptions were implemented. NRC expended significant engineering efforts in developing their concept antenna components including the application of using topology optimization.

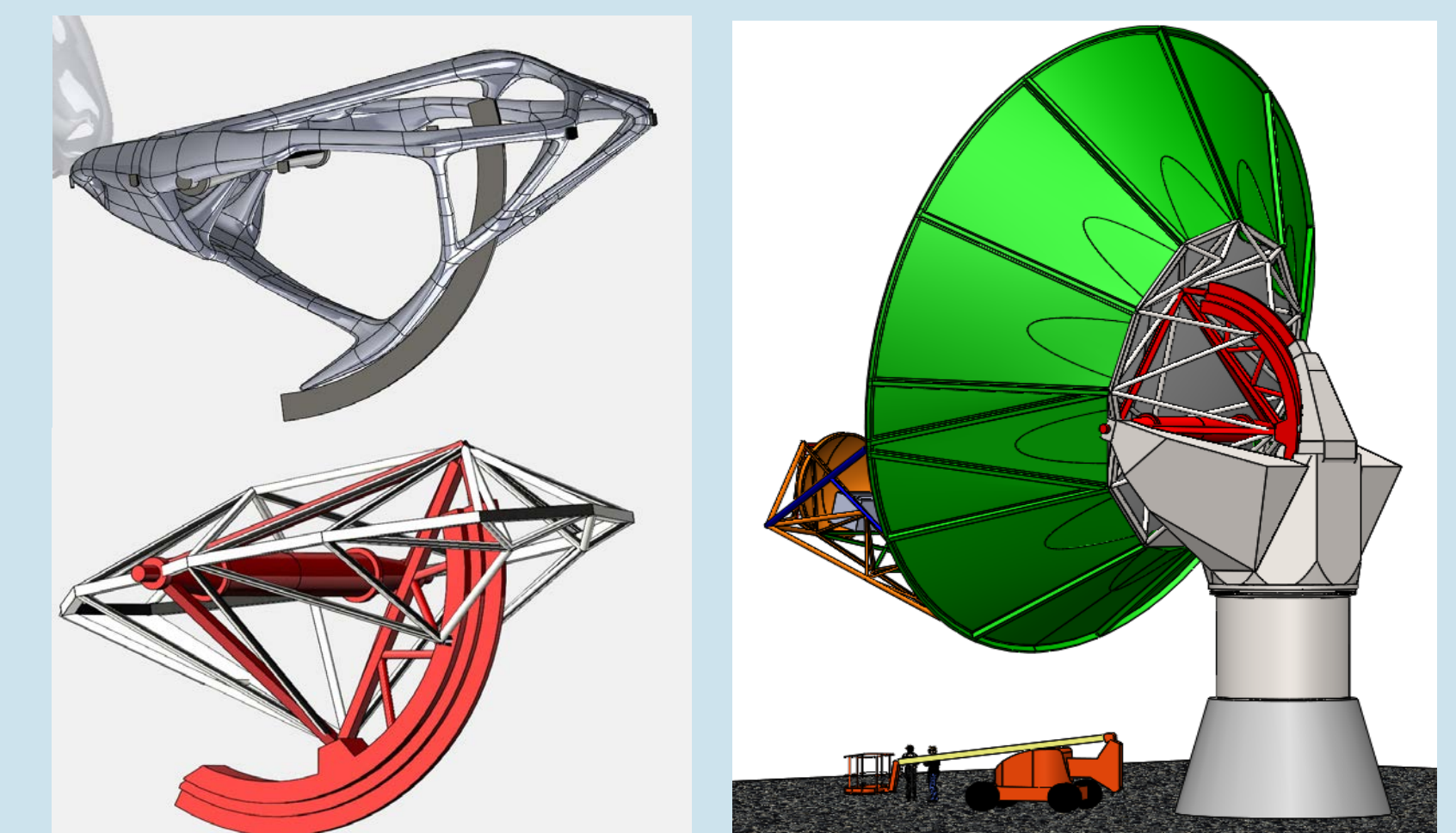

Figure 7: (left) iBUS optimization result (top) and rationalized structure (bottom) (right) Image of the 18m antenna with optimized iBUS structure

NRC has developed a surface adjustment concept that incorporates approximately 200 adjusters located around the perimeter of primary reflector surface allowing for minor correction of surface errors introduced from the molding process and gravity loading; ultimately resulting in a significant improvement in the overall surface accuracy of the composite surface.

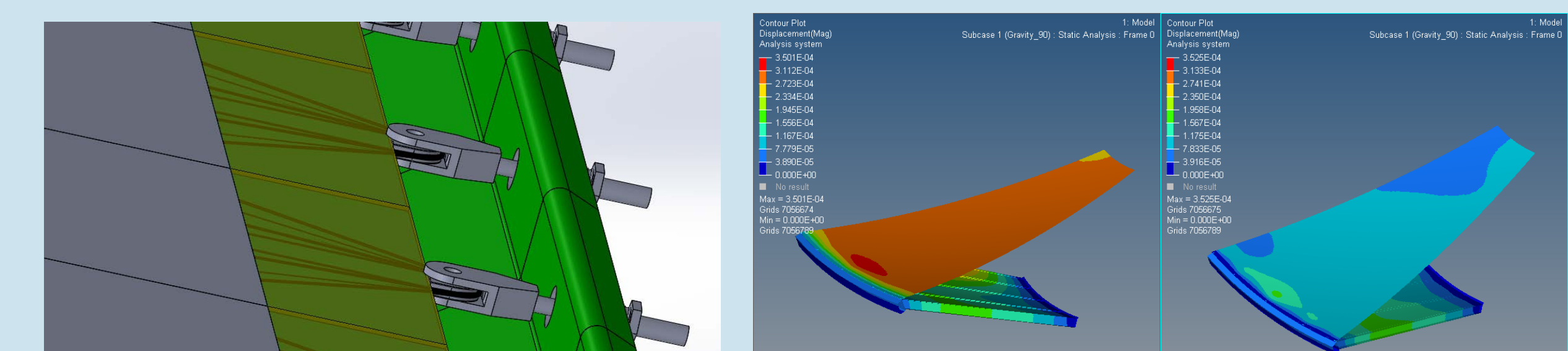

Figure 8: Surface Adjustment Concept

Figure 9: Surface Adjustment Modeling; Left before adjustment, right after adjustment (units are in meters).

Further Information

D. Dunbar et al. *ngVLA Antenna: Preliminary Technical Requirements*.

ngVLA Doc. 020.25.00.00.00-0001-Req. Rev B. 2018.

<http://ngvla.nrao.edu/>

